

Question Paper Preview

Question Paper Name: Instrumentation Engineering 4th May 2019 S1
Subject Name: Instrumentation Engineering
Duration: 120
Share Answer Key With Delivery Engine: Yes
Actual Answer Key: Yes

Instrumentation Engineering

Display Number Panel: Yes
Group All Questions: No

Question Number : 1 Question Id : 2501071681 Question Type : MCQ Option Shuffling : Yes Display Question Number : Yes Single Line Question Option : No Option Orientation : Vertical

For the matrix $A = \begin{bmatrix} 4 & 2 \\ 2 & 4 \end{bmatrix}$, the eigen value corresponding to the eigen vector $\begin{bmatrix} 101 \\ 101 \end{bmatrix}$ is _____.

Options :

1. 2
2. 4
3. 6
4. 8

Question Number : 2 Question Id : 2501071682 Question Type : MCQ Option Shuffling : Yes Display Question Number : Yes Single Line Question Option : No Option Orientation : Vertical

The area of the closed region in the xy – plane bounded by $y^2 = 4 - x$ and $y^2 = 4 - 4x$ is _____.

Options :

1.
$$\int_{-2}^2 \int_{\frac{y^2}{4}-1}^{y^2-4} dx dy$$

2.
$$\int_{-2}^2 \int_{1-\frac{y^2}{4}}^{4-y^2} dx dy$$

3.
$$\int_{-2}^2 \int_{\frac{1-y^2}{4}}^{4-y^2} dx dy$$

4.
$$\int_{-2}^2 \int_{4-y^2}^{1-\frac{y^2}{4}} dx dy$$

Question Number : 3 Question Id : 2501071683 Question Type : MCQ Option Shuffling : Yes Display Question Number : Yes Single Line Question Option : No Option Orientation : Vertical

If $f = 3x^2 - yz$ then $\nabla \cdot \nabla f = \underline{\hspace{2cm}}$.

Options :

1. 2

2. 4

3. 6

4. -4

Question Number : 4 Question Id : 2501071684 Question Type : MCQ Option Shuffling : Yes Display Question Number : Yes Single Line Question Option : No Option Orientation : Vertical

Which of the following is the solution of $y'' + y' - 2y = 0$

Options :

1. e^{-x}

2. e^{2x}

3. e^{x^2}

4. $e^{-2x} e^{-2x}$

Question Number : 5 Question Id : 2501071685 Question Type : MCQ Option Shuffling : Yes Display Question Number : Yes
Single Line Question Option : No Option Orientation : Vertical

Which of the following is the differential equation whose auxiliary equation has the roots 0, -1, 1 is ____.

Options :

1. $y'' - 2y = 0$

2. $y''' - y' = 0$

3. $y''' + y' = 0$

4. $y''' + 2y' = 0$

Question Number : 6 Question Id : 2501071686 Question Type : MCQ Option Shuffling : Yes Display Question Number : Yes
Single Line Question Option : No Option Orientation : Vertical

The value of $\int_C \frac{e^z}{(z-3)^2} dz$, where $C: |z| = 2$, is ____.

Options :

1. 0

2. πi

3. $2\pi i$

4. $8\pi i$

Question Number : 7 Question Id : 2501071687 Question Type : MCQ Option Shuffling : Yes Display Question Number : Yes
Single Line Question Option : No Option Orientation : Vertical

If E_1 and E_2 are any two events then which of the following is true?

Options :

1. $P(E_1/E_2) = P(E_1 \cap E_2) \cdot P(E_2)$

2. $P(E_1 \cap E_2) = P(E_1) \cdot P(E_2)$

3. $P(E_1 \cup E_2) = P(E_1) + P(E_2)$

4. $P(E_1 \cup E_2) \leq P(E_1) + P(E_2)$

Question Number : 8 Question Id : 2501071688 Question Type : MCQ Option Shuffling : Yes Display Question Number : Yes
Single Line Question Option : No Option Orientation : Vertical

If the probability density function of a random variable is defined as

$$f(x) = \begin{cases} 1+x, & -1 \leq x \leq 0 \\ 1-x, & 0 \leq x \leq 1 \end{cases}. \text{ Then the mean of the random variable is ____.$$

Options :

1. 0

2. $\frac{1}{6}$

3. $\frac{1}{\sqrt{6}}$

4. $\frac{-1}{2}$

Question Number : 9 Question Id : 2501071689 Question Type : MCQ Option Shuffling : Yes Display Question Number : Yes
Single Line Question Option : No Option Orientation : Vertical

Let $\frac{dy}{dx} = x - y$, $y(0) = 0$, $h = 0.1$. By Euler's method the value of $y(0.1)$ is _____.

Options :

1. 0
2. 0.1
3. 0.01
4. 0.031

Question Number : 10 Question Id : 2501071690 Question Type : MCQ Option Shuffling : Yes Display Question Number : Yes Single Line Question Option : No Option Orientation : Vertical

The Regula falsi method is related to _____ at a point of the curve.

Options :

1. chord
2. ordinate
3. abscissa
4. tangent

Question Number : 11 Question Id : 2501071691 Question Type : MCQ Option Shuffling : Yes Display Question Number : Yes Single Line Question Option : No Option Orientation : Vertical

Consider the following network

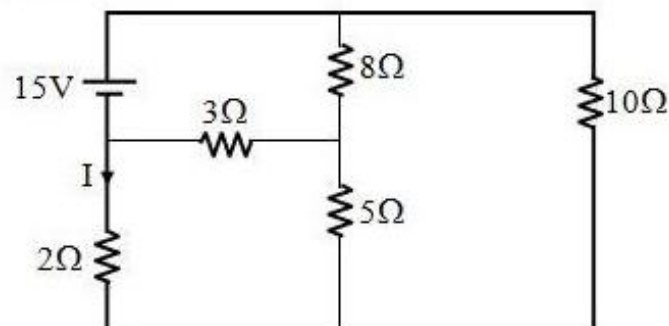

Find the value of current I is

Options :

1. -2.0 A

2. -2.4 A

3. -1.4 A

4. -1.0 A

Question Number : 12 Question Id : 2501071692 Question Type : MCQ Option Shuffling : Yes Display Question Number : Yes Single Line Question Option : No Option Orientation : Vertical

A 0-300V voltmeter has guaranteed accuracy of 1 % full scale reading. The voltage measured by the instrument is 83 V. The percent limiting error is

Options :

1. 0.95

2. 1.81

3. 3.62

4. 4.85

Question Number : 13 Question Id : 2501071693 Question Type : MCQ Option Shuffling : Yes Display Question Number : Yes Single Line Question Option : No Option Orientation : Vertical

A series R-L-C circuit is excited with an AC voltage source. The quality factor (Q) of the circuit is given as $Q = 30$. The amplitude of current in Ampere at upper half-power frequency will be _____.

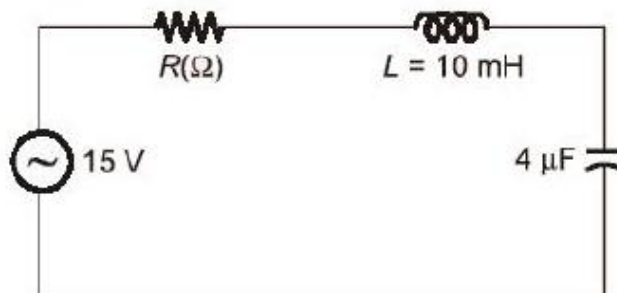

Options :

1. 0.63

2. 3.63

3. 1.6

4. 6.36

Question Number : 14 Question Id : 2501071694 Question Type : MCQ Option Shuffling : Yes Display Question Number : Yes
Single Line Question Option : No Option Orientation : Vertical

The dynamic characteristics of a measurement system among the given is

Options :

1. speed of response

2. accuracy

3. threshold

4. drift

Question Number : 15 Question Id : 2501071695 Question Type : MCQ Option Shuffling : Yes Display Question Number : Yes
Single Line Question Option : No Option Orientation : Vertical

A series RLC circuit has a resonance of 1 kHz and a quality factor $Q = 100$. If each R, L, and C is doubled from its original value, the new Q of the circuit is

Options :

1. 25

2. 50

3. 100

4. 200

Question Number : 16 Question Id : 2501071696 Question Type : MCQ Option Shuffling : Yes Display Question Number : Yes
Single Line Question Option : No Option Orientation : Vertical

An unshielded moving iron voltmeter is used to measure the voltage in an AC circuit. If a stray DC magnetic field having a component along the axis of the meter coil appears, the meter reading would be

Options :

1. unaffected
2. decreased
3. increased
4. either decreased or increased depending on the direction of the DC field

Question Number : 17 Question Id : 2501071697 Question Type : MCQ Option Shuffling : Yes Display Question Number : Yes
Single Line Question Option : No Option Orientation : Vertical

A piezoelectric type transducer has a sensitivity of 100 mV/g. The transducer is subjected to a constant acceleration of 5 g. What is the steady state output of the transducer?

Options :

1. 0 V
2. 100 mV
3. 0.5 V
4. 5 V

Question Number : 18 Question Id : 2501071698 Question Type : MCQ Option Shuffling : Yes Display Question Number : Yes
Single Line Question Option : No Option Orientation : Vertical

In a Strain gauge torque transducer, the strain gauges should be mounted at

Options :

1. 0° to the shaft axis
2. 45° to the shaft axis

3. 60° to the shaft axis

4. 90° to the shaft axis

Question Number : 19 Question Id : 2501071699 Question Type : MCQ Option Shuffling : Yes Display Question Number : Yes
Single Line Question Option : No Option Orientation : Vertical

Determine the dew point temperature and relative humidity, if the dry-bulb temperature is 24°C and the wet bulb temperature is 16°C .

Options :

1. 10°C and 42%

2. 10°C and 62%

3. 5°C and 42%

4. 5°C and 62%

Question Number : 20 Question Id : 2501071700 Question Type : MCQ Option Shuffling : Yes Display Question Number : Yes
Single Line Question Option : No Option Orientation : Vertical

The dynamic characteristics of capacitive transducers are similar to those of

Options :

1. low-pass filters

2. high pass filters

3. notch filters

4. band-pass filters

Question Number : 21 Question Id : 2501071701 Question Type : MCQ Option Shuffling : Yes Display Question Number : Yes
Single Line Question Option : No Option Orientation : Vertical

In a falling ball viscometer, the ball attains terminal velocities of 0.01 m/s for oil A and 0.02 m/s for oil B. Assuming both the oils have same densities and oil A has a kinematic viscosity of $5 \times 10^{-3} \text{m}^2/\text{s}$, the kinematic viscosity of oil B in m^2/s is

Options :

1. 15×10^{-3}
2. 20×10^{-3}
3. 25×10^{-3}
4. 30×10^{-3}

Question Number : 22 Question Id : 2501071702 Question Type : MCQ Option Shuffling : Yes Display Question Number : Yes
Single Line Question Option : No Option Orientation : Vertical

Poisson's ratio for a metal is 0.35 neglecting piezo resistance effect, the gage factor of a strain gage made of this metal is _____.

Options :

1. 0.65
2. 1
3. 1.35
4. 1.70

Question Number : 23 Question Id : 2501071703 Question Type : MCQ Option Shuffling : Yes Display Question Number : Yes
Single Line Question Option : No Option Orientation : Vertical

A differential pressure transmitter is used to measure the flow rate in a pipe. Due to aging, the sensitivity of the pressure transmitter is reduced by 5%. All other aspects of the flow meter remaining constant, change in the sensitivity of the flow measurement is

Options :

1. 10.0%

2. 5.0%

3. 2.5%

4. 2.2%

Question Number : 24 Question Id : 2501071704 Question Type : MCQ Option Shuffling : Yes Display Question Number : Yes
Single Line Question Option : No Option Orientation : Vertical

What is the formula of torque (τ)?

Options :

1. $\tau = I\alpha$

2. $\tau = r\alpha$

3. $\tau = ma$

4. $\tau = r^2\alpha$

Question Number : 25 Question Id : 2501071705 Question Type : MCQ Option Shuffling : Yes Display Question Number : Yes
Single Line Question Option : No Option Orientation : Vertical

Orifice meter is used to measure _____.

Options :

1. average velocity

2. discharge

3. velocity at a point

4. pressure at a point

Question Number : 26 Question Id : 2501071706 Question Type : MCQ Option Shuffling : Yes Display Question Number : Yes
Single Line Question Option : No Option Orientation : Vertical

A thermistor has a resistance temperature coefficient of 5% over a temperature range of 25°C to 50°C. If the resistance of the thermistor is 100 Ω at 25°C, what is the resistance at 35°C?

Options :

1. 200 Ω
2. 150 Ω
3. 100 Ω
4. 50 Ω

Question Number : 27 Question Id : 2501071707 Question Type : MCQ Option Shuffling : Yes Display Question Number : Yes
Single Line Question Option : No Option Orientation : Vertical

In a venturi tube flowmeter, the flow rate is 0.15 m³/s when the differential pressure is 30 kN/m². What is the flow rate when the differential pressure is 60 kN/m²?

Options :

1. 0.212 m³/s
2. 0.106 m³/s
3. 0.3 m³/s
4. 0.075 m³/s

Question Number : 28 Question Id : 2501071708 Question Type : MCQ Option Shuffling : Yes Display Question Number : Yes
Single Line Question Option : No Option Orientation : Vertical

Which of the following temperature sensor is most linear?

Options :

1. Thermocouple
2. RTD

3. Thermistor

4. IC temperature sensor

Question Number : 29 Question Id : 2501071709 Question Type : MCQ Option Shuffling : Yes Display Question Number : Yes
Single Line Question Option : No Option Orientation : Vertical

Very high temperature (1200-1700°C) will be measured precisely by

Options :

1. radiation pyrometer

2. optical pyrometer

3. thermocouple

4. bi-metallic thermometer

Question Number : 30 Question Id : 2501071710 Question Type : MCQ Option Shuffling : Yes Display Question Number : Yes
Single Line Question Option : No Option Orientation : Vertical

The dead zone in a certain pyrometer is 0.125% of span. The calibration is 400°C to 1000°C. What temperature difference might occur before it is detected?

Options :

1. 0.25°C

2. 0.75°C

3. 7.5°C

4. 2.5°C

Question Number : 31 Question Id : 2501071711 Question Type : MCQ Option Shuffling : Yes Display Question Number : Yes
Single Line Question Option : No Option Orientation : Vertical

The transfer function of a system is $G(s) = \frac{100e^{-st}}{s(s+10)}$. The system _____.

Options :

1. has a transportation lag
2. is a non linear system
3. is a linear system
4. has a zero dead time

Question Number : 32 Question Id : 2501071712 Question Type : MCQ Option Shuffling : Yes Display Question Number : Yes
Single Line Question Option : No Option Orientation : Vertical

Magnetic flux can be measured by which of these transducers?

Options :

1. Capacitive pickup
2. Inductive pickup
3. Piezo electric pickup
4. Hall effect pickup

Question Number : 33 Question Id : 2501071713 Question Type : MCQ Option Shuffling : Yes Display Question Number : Yes
Single Line Question Option : No Option Orientation : Vertical

Assuming complete dissociation, the pH of a 1 mm solution of H_2SO_4 is closest to

Options :

1. 3
2. 2.7
3. 2.4
4. 2.1

Question Number : 34 Question Id : 2501071714 Question Type : MCQ Option Shuffling : Yes Display Question Number : Yes
Single Line Question Option : No Option Orientation : Vertical

A thermometer with a time constant of 0.5 min is introduced in a bath where the temperature is increasing at a constant rate of $5^{\circ}\text{C}/\text{min}$. The steady state error in the thermometer reading is

Options :

1. 10°C
2. 2.5°C
3. 0.1°C
4. 0.4°C

Question Number : 35 Question Id : 2501071715 Question Type : MCQ Option Shuffling : Yes Display Question Number : Yes
Single Line Question Option : No Option Orientation : Vertical

Pirani gauge is used to measure the pressure in the range of

Options :

1. 10^{-8} mm to 10^{-5} mm of Hg
2. 10^{-3} mm to 10^{-4} mm of Hg
3. 10 mm to 10^{-1} mm of Hg
4. 10^{-1} mm to 10^{-3} mm of Hg

Question Number : 36 Question Id : 2501071716 Question Type : MCQ Option Shuffling : Yes Display Question Number : Yes
Single Line Question Option : No Option Orientation : Vertical

The input impedance (Z_i) and the output impedance (Z_o) of an ideal transconductance amplifier are

Options :

1. $Z_i = 0, Z_o = 0$
2. $Z_i = 0, Z_o = \infty$

3. $Z_i = \infty, Z_o = 0$

4. $Z_i = \infty, Z_o = \infty$

Question Number : 37 Question Id : 2501071717 Question Type : MCQ Option Shuffling : Yes Display Question Number : Yes
Single Line Question Option : No Option Orientation : Vertical

An Op-amp has input voltage of $V_{i1} = 150 \mu\text{V}$, $V_{i2} = 140 \mu\text{V}$ and the amplifier has a differential gain of $A_d = 4000$ and the value of CMRR is 100, then its output is

Options :

1. 45.8 mV

2. 40.006 mV

3. 10 μV

4. 145 μV

Question Number : 38 Question Id : 2501071718 Question Type : MCQ Option Shuffling : Yes Display Question Number : Yes
Single Line Question Option : No Option Orientation : Vertical

For the Si transistor circuit shown below $\beta = 100$, then the base current (in μA) is

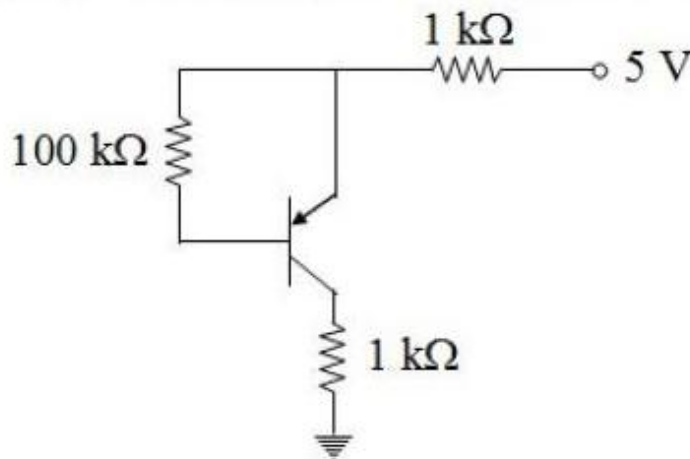

Options :

1. 0.42

2. 0

3. 0.5

1

4.

Question Number : 39 Question Id : 2501071719 Question Type : MCQ Option Shuffling : Yes Display Question Number : Yes Single Line Question Option : No Option Orientation : Vertical

Considering the resistances of emitter, collector and base to be R_e , R_c and R_b respectively, which of the following statements is correct?

Options :

1. $R_e > R_b > R_c$

1.

2. $R_c > R_b > R_e$

2.

3. $R_b > R_c > R_e$

3.

4. $R_b > R_e > R_c$

4.

Question Number : 40 Question Id : 2501071720 Question Type : MCQ Option Shuffling : Yes Display Question Number : Yes Single Line Question Option : No Option Orientation : Vertical

The output voltage (V_{out}) of the following circuit is

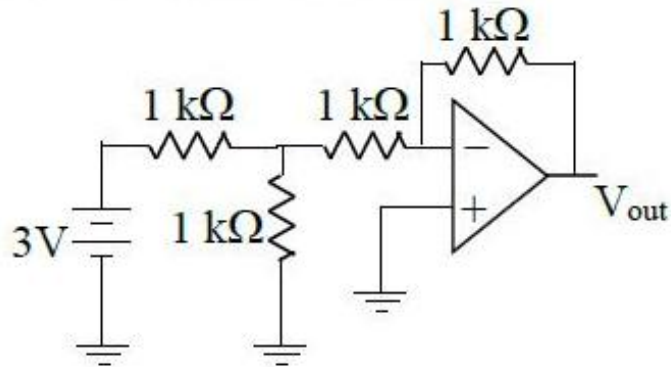

Options :

1. -1 V

1.

2. -1.5 V

2.

3. -2 V

3.

4. -0.5 V

4.

The dual of the Boolean theorem $A.(B + C) = A.B + A.C$

Options :

1. $A + (B + C) = A.B + A.C$
2. $A.(B + C) = (A + B)(A + C)$
3. $A + B.C = (A + B)(A + C)$
4. $A + (B.C) = (A.B) + (A.C)$

For logic circuit, shown, if A, B and C are applied a sequence of pulses equivalent to 9, 6, B (hexadecimal) having the same interval of time, what will be the output X, if it is represented in hexadecimal?

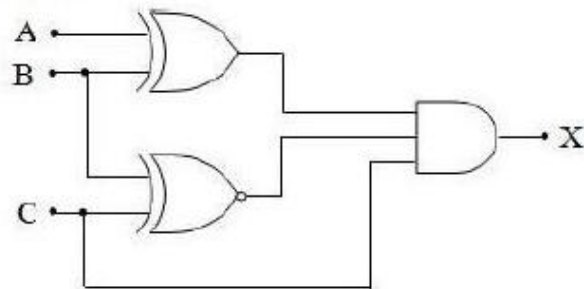

Options :

1. 4
2. A
3. 6
4. 2

A combinational logic circuit which sends data coming from a single source to two or more separate destinations is

Options :

1. decoder
2. encoder
3. multiplexer
4. demultiplexer

Question Number : 44 Question Id : 2501071724 Question Type : MCQ Option Shuffling : Yes Display Question Number : Yes Single Line Question Option : No Option Orientation : Vertical

The following logic circuit is

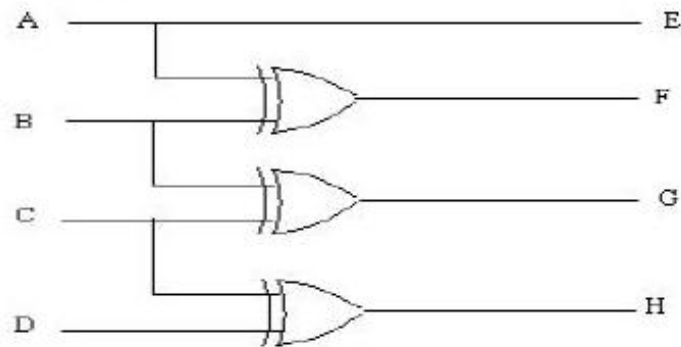

- Options :
1. gray to binary converter
 2. equality checker
 3. binary to gray converter
 4. even parity checker

Question Number : 45 Question Id : 2501071725 Question Type : MCQ Option Shuffling : Yes Display Question Number : Yes Single Line Question Option : No Option Orientation : Vertical

Number of literals possible in the minimised expression of the following boolelan function K having a function of six variables A,B,C,D,E,F (where A is MSB, F is LSB) is _____.

$$K(A,B,C,D,E,F) = \sum m(5,7,15,21,23,29,31,37,39,45,47,53,55,61,63)$$

- Options :
1. 4

2. 6

3. 2

4. 5

Question Number : 46 Question Id : 2501071726 Question Type : MCQ Option Shuffling : Yes Display Question Number : Yes
Single Line Question Option : No Option Orientation : Vertical

What is the size of the Program Counter (PC) to access 1 KB and 1 MB memory?

Options :

1. 20 bits and 10 bits

2. 10 bits and 20 bits

3. 10 bits and 15 bits

4. 20 bits and 15 bits

Question Number : 47 Question Id : 2501071727 Question Type : MCQ Option Shuffling : Yes Display Question Number : Yes
Single Line Question Option : No Option Orientation : Vertical

In a 4 bit weighted resistor D/A converter, the resistor value corresponding to LSB is 32 K Ω . The resistor value corresponding to MSB will be

Options :

1. 4 K Ω

2. 8 K Ω

3. 16 K Ω

4. 32 K Ω

Question Number : 48 Question Id : 2501071728 Question Type : MCQ Option Shuffling : Yes Display Question Number : Yes
Single Line Question Option : No Option Orientation : Vertical

The internal data memory of 8051 microcontroller has

Options :

1. 256 bytes
2. 128 bytes
3. 4kB
4. 2kB

Question Number : 49 Question Id : 2501071729 Question Type : MCQ Option Shuffling : Yes Display Question Number : Yes
Single Line Question Option : No Option Orientation : Vertical

For a 4×1 MUX, if the inputs are connected with $I_0 = 0$; $I_1 = 1$; $I_2 = 1$ and $I_3 = 0$, and the select link s_1 and s_0 are connected to input A and B respectively. Then the circuit behaves as _____.

Options :

1. adder
2. SR-latch
3. 4×1 Mux
4. XOR circuit

Question Number : 50 Question Id : 2501071730 Question Type : MCQ Option Shuffling : Yes Display Question Number : Yes
Single Line Question Option : No Option Orientation : Vertical

The subroutine SBX given below is executed by an 8085 microprocessor. The value in the accumulator immediately after the execution of the subroutine will be

```
SBX:  MVIA, 99H
      ADI 11H
      MOV C, A
      RET
```

Options :

1. 00H

2. 11H

3. 99H

4. AAH

Question Number : 51 Question Id : 2501071731 Question Type : MCQ Option Shuffling : Yes Display Question Number : Yes
Single Line Question Option : No Option Orientation : Vertical

The output of a linear system to a unit step $u(t)$ is $t^2 e^t$. The system function $H(s)$ is

Options :

1. $2/s^2(s+2)$

2. $2/(s+2)^2$

3. $2/(s+2)^3$

4. $2s/(2+s)^3$

Question Number : 52 Question Id : 2501071732 Question Type : MCQ Option Shuffling : Yes Display Question Number : Yes
Single Line Question Option : No Option Orientation : Vertical

What is the time period of $x(t) = 7 e^{j\left\{5t+\frac{\pi}{2}\right\}} + 10 e^{j\left\{7t+\frac{\pi}{5}\right\}}$

Options :

1. $\frac{1}{2\pi}$

2. 2π

3. 4π

4. not periodic

Question Number : 53 Question Id : 2501071733 Question Type : MCQ Option Shuffling : Yes Display Question Number : Yes
Single Line Question Option : No Option Orientation : Vertical

In PCM encoding, quantization level varies as a function of _____.

Options :

1. frequency
2. amplitude
3. square of frequency
4. square of amplitude

Question Number : 54 Question Id : 2501071734 Question Type : MCQ Option Shuffling : Yes Display Question Number : Yes
Single Line Question Option : No Option Orientation : Vertical

The fundamental period of $x(t) = 2 \sin(2\pi t) + 3 \sin(3\pi t)$, where t expressed in seconds, is

Options :

1. 2s
2. 0.67s
3. 1s
4. 3s

Question Number : 55 Question Id : 2501071735 Question Type : MCQ Option Shuffling : Yes Display Question Number : Yes
Single Line Question Option : No Option Orientation : Vertical

The Fourier series of an odd periodic function, contains only

Options :

1. odd harmonics
2. even harmonics
3. cosine terms
4. sine terms

Question Number : 56 Question Id : 2501071736 Question Type : MCQ Option Shuffling : Yes Display Question Number : Yes
Single Line Question Option : No Option Orientation : Vertical

Impulse invariant technique is suitable only for

Options :

1. low pass filter
2. narrow band pass filter
3. high pass filter
4. band reject filter

Question Number : 57 Question Id : 2501071737 Question Type : MCQ Option Shuffling : Yes Display Question Number : Yes
Single Line Question Option : No Option Orientation : Vertical

A periodic signal has 40Hz bandwidth and the highest frequency is 80Hz. What is the lowest frequency?

Options :

1. 100 Hz
2. 40 Hz
3. 80Hz
4. 120 Hz

Question Number : 58 Question Id : 2501071738 Question Type : MCQ Option Shuffling : Yes Display Question Number : Yes
Single Line Question Option : No Option Orientation : Vertical

$x(t)$ is a low frequency modulating signal and $\cos(\omega_c t)$ is a carrier signal with frequency f_c then $x(t) \cos(\omega_c t)$ has

Options :

1. carrier and both the sidebands
2. both the sidebands but no carrier component

3. carrier and only the upper sideband

4. carrier and only the lower sideband

Question Number : 59 Question Id : 2501071739 Question Type : MCQ Option Shuffling : Yes Display Question Number : Yes
Single Line Question Option : No Option Orientation : Vertical

A digital filter has the transfer function $H(z) = z^2 + 1/z^2 + 0.81$. If this filter has to reject 50 Hz interference from the input, then the sampling frequency of the input should be

Options :

1. 200 Hz

2. 150 Hz

3. 100 Hz

4. 50 Hz

Question Number : 60 Question Id : 2501071740 Question Type : MCQ Option Shuffling : Yes Display Question Number : Yes
Single Line Question Option : No Option Orientation : Vertical

Which of the following functions relates the Z-transform of the output at the sampling instants to that of the sampling input?

Options :

1. Impulse function

2. Ramp function

3. Pulse transfer function

4. Dirac delta function

Question Number : 61 Question Id : 2501071741 Question Type : MCQ Option Shuffling : Yes Display Question Number : Yes
Single Line Question Option : No Option Orientation : Vertical

A quantizer operates at a sampling frequency of 16 kHz. What is its Nyquist limit?

Options :

1. 64 kHz
2. 32 kHz
3. 16 kHz
4. 8 kHz

Question Number : 62 Question Id : 2501071742 Question Type : MCQ Option Shuffling : Yes Display Question Number : Yes
Single Line Question Option : No Option Orientation : Vertical

An LTI system with flat magnitude response is producing a constant time delay of t seconds for all frequencies. If $h(t)$ is the impulse response of the system then

Options :

1. $h(t)$ take a maximum value at $t = \frac{\tau}{2}$
2. $h(t)$ take a minimum value at $t = \frac{\tau}{2}$
3. $h(t)$ take a maximum value at $t = Z$
4. $h(t)$ take a minimum value at $t = Z$

Question Number : 63 Question Id : 2501071743 Question Type : MCQ Option Shuffling : Yes Display Question Number : Yes
Single Line Question Option : No Option Orientation : Vertical

In a pulse code modulated (PCM) signal sampled at f_s and encoded into an 'n' bit code, the minimum bandwidth required for faithful reconstruction is

Options :

1. $2nf_s$
2. nf_s

3. $nf_s/2$

4. f_s

Question Number : 64 Question Id : 2501071744 Question Type : MCQ Option Shuffling : Yes Display Question Number : Yes
Single Line Question Option : No Option Orientation : Vertical

An over modulated signal cannot be demodulated by using

Options :

1. Square Law detector
2. Envelope detector
3. Both square Law and Envelope detectors
4. Enclosed detector

Question Number : 65 Question Id : 2501071745 Question Type : MCQ Option Shuffling : Yes Display Question Number : Yes
Single Line Question Option : No Option Orientation : Vertical

A PLL can be used to demodulate

Options :

1. FM signal
2. PAM signal
3. PCM signal
4. DSB-SC signal

Question Number : 66 Question Id : 2501071746 Question Type : MCQ Option Shuffling : Yes Display Question Number : Yes
Single Line Question Option : No Option Orientation : Vertical

A DC ammeter has a resistance of 0.1Ω and its current range is 0-100 A. If the range of the ammeter is to extend to 0-500 A, the meter requires which of the following shunt resistance?

Options :

1. 0.010 Ω

2. 0.025 Ω

3. 0.011 Ω

4. 1.0 Ω

Question Number : 67 Question Id : 2501071747 Question Type : MCQ Option Shuffling : Yes Display Question Number : Yes
Single Line Question Option : No Option Orientation : Vertical

Maxwell's inductance –capacitance bridge is used for measurement of inductance of _____.

Options :

1. low Q coils

2. medium Q coils

3. high Q coils

4. low and medium Q coils

Question Number : 68 Question Id : 2501071748 Question Type : MCQ Option Shuffling : Yes Display Question Number : Yes
Single Line Question Option : No Option Orientation : Vertical

A stationary closed Lissajous pattern on an oscilloscope has 8 horizontal tangencies for a horizontal & vertical inputs with frequencies of 3 KHz & 2 KHz respectively. Then the vertical tangencies are

Options :

1. 10

2. 16

3. 8

Question Number : 69 Question Id : 2501071749 Question Type : MCQ Option Shuffling : Yes Display Question Number : Yes
Single Line Question Option : No Option Orientation : Vertical

A (0 – 200) V voltmeter has a guaranteed accuracy of $\pm 1\%$ of full scale reading. If the voltage measured by this instrument is 180 V, then the limiting error will be

Options :

1. Less than $\pm 1\%$
2. Less than $\pm 2\%$ but greater than $\pm 1\%$
3. Less than $\pm 3\%$ but greater than $\pm 2\%$
4. $\pm 2\%$

Question Number : 70 Question Id : 2501071750 Question Type : MCQ Option Shuffling : Yes Display Question Number : Yes
Single Line Question Option : No Option Orientation : Vertical

The sensitivity of PMMC instrument is $10 \text{ K}\Omega/\text{V}$. If this instrument is used in a rectifier type voltmeter with half wave rectification, what would be the sensitivity?

Options :

1. $10 \text{ K}\Omega/\text{V}$
2. $5 \text{ K}\Omega/\text{V}$
3. $4.5 \text{ K}\Omega/\text{V}$
4. $22.2 \text{ K}\Omega/\text{V}$

Question Number : 71 Question Id : 2501071751 Question Type : MCQ Option Shuffling : Yes Display Question Number : Yes
Single Line Question Option : No Option Orientation : Vertical

The Q factor of coil at the resonant frequency 1.5 MHz of an RLC series circuit is 150. The bandwidth will be

Options :

1. 225 MHz

2. 1.06 MHz

3. 100 kHz

4. 10 kHz

Question Number : 72 Question Id : 2501071752 Question Type : MCQ Option Shuffling : Yes Display Question Number : Yes
Single Line Question Option : No Option Orientation : Vertical

Wagner's earth devices used on AC bridge circuit for

Options :

1. eliminating the effect of inter-component capacitances

2. eliminating the effect of strong electrostatic fields

3. shielding the bridge elements

4. eliminating the effect of each capacitance.

Question Number : 73 Question Id : 2501071753 Question Type : MCQ Option Shuffling : Yes Display Question Number : Yes
Single Line Question Option : No Option Orientation : Vertical

A current $0.5 + 0.4 \sin \omega t + 0.2 \sin \omega t$ is passing through the circuit shown in the figure below. The reading of the M.C. instrument is _____ amp.

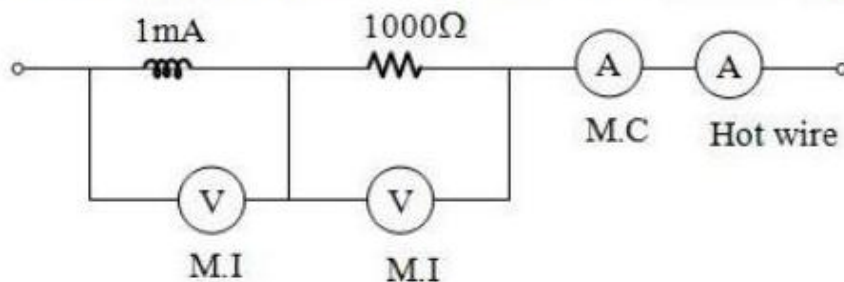

Options :

1. 1.0

2. 1.5

3. 0.5

4. 2.5

Question Number : 74 Question Id : 2501071754 Question Type : MCQ Option Shuffling : Yes Display Question Number : Yes
Single Line Question Option : No Option Orientation : Vertical

The potentiometer wire should have

Options :

1. high specific resistance and high temperature coefficient.

2. high specific resistance and low temperature coefficient.

3. low specific resistance and high temperature coefficient.

4. low specific resistance and low temperature coefficient.

Question Number : 75 Question Id : 2501071755 Question Type : MCQ Option Shuffling : Yes Display Question Number : Yes
Single Line Question Option : No Option Orientation : Vertical

An integrating digital voltmeter measures

Options :

1. true average value

2. rms value

3. peak value

4. peak to peak value

Question Number : 76 Question Id : 2501071756 Question Type : MCQ Option Shuffling : Yes Display Question Number : Yes
Single Line Question Option : No Option Orientation : Vertical

In the AC bridge, shown in the figure, $R = 10^3 \Omega$ and $C = 10^{-7} \text{ F}$. If the bridge is balanced at a frequency ω_0 , the value of ω_0 in rad/s is,

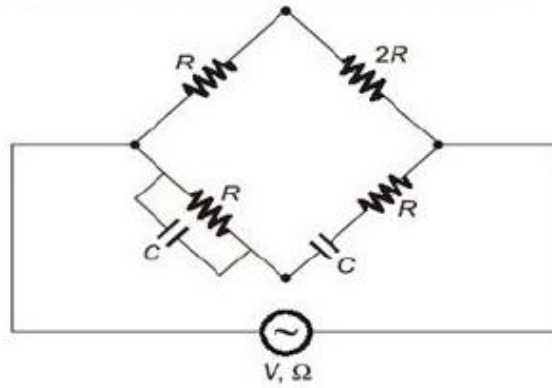

Options :

1. 100
2. 100000
3. 10000
4. 1000

Question Number : 77 Question Id : 2501071757 Question Type : MCQ Option Shuffling : Yes Display Question Number : Yes Single Line Question Option : No Option Orientation : Vertical

A voltage, represented as $100 \sin \omega t + 40 \cos(3 \omega t - \pi/4) + 50 \cos(5 \omega t - \frac{\pi}{6})$ is applied to the voltage coil of a wattmeter. Current of $8 \sin \omega t + 6 \cos(3 \omega t - 2\pi/3)$ is passed through current coils then the wattmeter reading will be _____
($\cos(75) = 0.92$)

Options :

1. 431 W
2. 420 W
3. 435 W
4. 421 W

A Kelvin double bridge is best suited for the measurement of

Options :

1. very high resistance
2. inductance
3. high resistance
4. low resistance

X and Y plates of a CRO are connected to unequal voltages of equal frequency with phase shift of 90° . The Lissajous figure on the screen will be

Options :

1. circle
2. straight line
3. ellipse
4. figure of eight

Phase-sensitive detectors are used for measuring phase of _____.

Options :

1. Sinusoidal signals only
2. non periodic signals only

Periodic signals only

3.

both periodic and non-periodic signals

4.

Question Number : 81 Question Id : 2501071761 Question Type : MCQ Option Shuffling : Yes Display Question Number : Yes
Single Line Question Option : No Option Orientation : Vertical

Which of the following transfer function represents second order linear time-invariant system with under-damped system.

Options :

$$H(s) = \frac{1}{s^2 + 4s + 4}$$

1.

$$H(s) = \frac{1}{s^2 + 5s + 4}$$

2.

$$H(s) = \frac{1}{s^2 + 4.5s + 4}$$

3.

$$H(s) = \frac{1}{s^2 + 3s + 4}$$

4.

Question Number : 82 Question Id : 2501071762 Question Type : MCQ Option Shuffling : Yes Display Question Number : Yes
Single Line Question Option : No Option Orientation : Vertical

Two ammeters are joined in series circuit carrying 10 A. One ammeter has a resistance of 1000 Ω shunted by 0.05 Ω while other ammeter has resistance of 1500 Ω shunted by 0.02 Ω . If the shunts are interchanged, what will be readings of ammeters?

Options :

25 A, 4 A

1.

4 A, 25 A

2.

3 A, 22 A

3.

22 A, 3 A

4.

Question Number : 83 Question Id : 2501071763 Question Type : MCQ Option Shuffling : Yes Display Question Number : Yes
Single Line Question Option : No Option Orientation : Vertical

An amplifier with resistive negative feedback has two left half plane poles in its open-loop transfer function. The amplifier

Options :

1. will be stable for all frequencies
2. will always be unstable at high frequencies
3. may be unstable, depending on the feedback factor
4. will oscillate at low frequencies

Question Number : 84 Question Id : 2501071764 Question Type : MCQ Option Shuffling : Yes Display Question Number : Yes
Single Line Question Option : No Option Orientation : Vertical

A 50 V M.I. voltmeter has a resistance of $400\ \Omega$ made up of a copper coil of $40\ \Omega$ and $80\ \text{mH}$ in series with a non-inductive resistance of $360\ \Omega$. The value of the capacitor connected to the instrument, so that instrument will read correctly on DC and AC is ___ μF .

Options :

1. 0.25
2. 0.5
3. 0.6
4. 2.5

Question Number : 85 Question Id : 2501071765 Question Type : MCQ Option Shuffling : Yes Display Question Number : Yes
Single Line Question Option : No Option Orientation : Vertical

The oscilloscope has input resistance of $1\ \text{M}\Omega$ and capacitance of $5\ \text{pF}$ and the voltage divider ratio (K) is 10. What are the parameters of high input impedance probe?

Options :

1. 0.55 pF, 18 MΩ

2. 0.55 pF, 9 MΩ

3. 66 pF, 20 MΩ

4. 0.5 pF, 9 MΩ

Question Number : 86 Question Id : 2501071766 Question Type : MCQ Option Shuffling : Yes Display Question Number : Yes
Single Line Question Option : No Option Orientation : Vertical

The maximum phase shift that can be provided by a lead compensator with transfer

function $G(s) = \frac{1+6s}{1+2s}$ is

Options :

1. 15°

2. 30°

3. 45°

4. 60°

Question Number : 87 Question Id : 2501071767 Question Type : MCQ Option Shuffling : Yes Display Question Number : Yes
Single Line Question Option : No Option Orientation : Vertical

The proportional gain (K) of a PID controller can be expressed in terms of its Proportional Band (PB) as

Options :

1. PB

2. $100 \times PB$

3. $PB/100$

100/PB

4.

Question Number : 88 Question Id : 2501071768 Question Type : MCQ Option Shuffling : Yes Display Question Number : Yes
Single Line Question Option : No Option Orientation : Vertical

In the Bode plot of a unity feedback control system, the value of phase of $G(j\omega)$ at the gain crossover frequency is -120° . The phase margin of the system is

Options :

1. -120°

2.

3. -60°

4.

5. 60°

6.

7. 120°

8.

Question Number : 89 Question Id : 2501071769 Question Type : MCQ Option Shuffling : Yes Display Question Number : Yes
Single Line Question Option : No Option Orientation : Vertical

A unity feedback system has an open loop transfer function $G(s) = \frac{k}{s(s+3)}$. The value of k that yields a damping ratio of 0.5 for the closed loop system is

Options :

1. 1

2.

3. 3

4.

5. 5

6.

7. 9

8.

Question Number : 90 Question Id : 2501071770 Question Type : MCQ Option Shuffling : Yes Display Question Number : Yes
Single Line Question Option : No Option Orientation : Vertical

A linear time-invariant single-input single-output system has a state space model given by $\frac{dx}{dt} = Fx + Gu$, $y = Hx$, where, x is the state vector, u is the input, and y is the output.

$$F = \begin{bmatrix} 0 & 1 \\ -4 & -2 \end{bmatrix}; G = \begin{bmatrix} 0 \\ 1 \end{bmatrix}; H = [1 \quad 0]$$

The damping ratio of the system is

Options :

1. 0.25
2. 0.5
3. 1
4. 2

Question Number : 91 Question Id : 2501071771 Question Type : MCQ Option Shuffling : Yes Display Question Number : Yes
Single Line Question Option : No Option Orientation : Vertical

Time taken for the response to reach and stay within a specified error is called _____ time.

Options :

1. rise
2. settling
3. delay
4. peak

Question Number : 92 Question Id : 2501071772 Question Type : MCQ Option Shuffling : Yes Display Question Number : Yes
Single Line Question Option : No Option Orientation : Vertical

The intersection of asymptotes of root loci of a system with open loop transfer function $G(s)H(s) = \frac{K}{s(s+1)(s+3)}$ is

Options :

1. 1.44
2. 1.33
3. -1.44
4. -1.33

Question Number : 93 Question Id : 2501071773 Question Type : MCQ Option Shuffling : Yes Display Question Number : Yes
Single Line Question Option : No Option Orientation : Vertical

A transfer function has two zeros at infinity. Then the relation between the numerator degree (N) and the denominator degree (M) of the transfer function is

Options :

1. $N = M + 2$
2. $N = M - 2$
3. $N = M + 1$
4. $N = M - 1$

Question Number : 94 Question Id : 2501071774 Question Type : MCQ Option Shuffling : Yes Display Question Number : Yes
Single Line Question Option : No Option Orientation : Vertical

A system with transfer function $\frac{1}{\tau s + 1}$ is subjected to a step input and takes 10 seconds to reach 50% of the final value. What is the value of τ ?

Options :

1. 6.9 s
2. 10 s
3. 14.4 s

20 s

4.

Question Number : 95 Question Id : 2501071775 Question Type : MCQ Option Shuffling : Yes Display Question Number : Yes
Single Line Question Option : No Option Orientation : Vertical

A temperature control system is usually very sluggish. To improve its dynamics _____ can be used.

Options :

1. a PI controller

2.

an integral controller

3.

a PID controller with large I and negligible D action

4.

a PD controller

4.

Question Number : 96 Question Id : 2501071776 Question Type : MCQ Option Shuffling : Yes Display Question Number : Yes
Single Line Question Option : No Option Orientation : Vertical

Identify the sequence of operation in fuzzy control.

I) Rule base

II) Fuzzification

III) Fuzzy inference

IV) Defuzzification

Options :

1. I-II-III-IV

2.

II-I-IV-III

3.

II-I III-IV

4.

I-III-II-IV

4.

Question Number : 97 Question Id : 2501071777 Question Type : MCQ Option Shuffling : Yes Display Question Number : Yes
Single Line Question Option : No Option Orientation : Vertical

Which of the following controller produces zero offset?

Options :

1. On-Off control
2. Proportional
3. Derivative
4. Integral

Question Number : 98 Question Id : 2501071778 Question Type : MCQ Option Shuffling : Yes Display Question Number : Yes
Single Line Question Option : No Option Orientation : Vertical

Consider a unity feedback control system whose forward path transfer function $G(s) = k/s^2$. The steady state error, for a step input is

Options :

1. 1.0
2. infinite
3. 0.0
4. unknown

Question Number : 99 Question Id : 2501071779 Question Type : MCQ Option Shuffling : Yes Display Question Number : Yes
Single Line Question Option : No Option Orientation : Vertical

Which of the following motors would be suitable for use as servomotors?

1. Two –phase induction motor.
2. DC separately excited motor.
3. Single-phase capacitance starts induction motor.
4. Universal motor.
5. Single-phase synchronous motors.

Options :

1. 1, 2, 3, 4 and 5
2. 2, 3, and 4

3. 1, 2, and 5

4. 1 and 5

Question Number : 100 Question Id : 2501071780 Question Type : MCQ Option Shuffling : Yes Display Question Number : Yes
Single Line Question Option : No Option Orientation : Vertical

A PID controller has the transfer function $2 + \frac{0.4}{s}$ with the unit of time expressed in minute. The parameters proportional to band and reset time for the above controller are respectively

Options :

1. 200% and 1.4 min.

2. 50% and 0.4 min.

3. 50% and 5 min.

4. 200% and 5 min.

Question Number : 101 Question Id : 2501071781 Question Type : MCQ Option Shuffling : Yes Display Question Number : Yes
Single Line Question Option : No Option Orientation : Vertical

A unit step input is applied to a unity feedback control system whose open loop transfer function is given by $G(s) = \frac{k}{s(sT + 1)}$. Given that maximum overshoot is 26% and resonant frequency is 8 rad/s, the values of K and T are

Options :

1. $K = 0.26, T = 9.6s$

2. $K = 12.1, T = 0.13s$

3. $K = 0.13, T = 12.1s$

$$K = 12.1, T = 9.6s$$

4.

Question Number : 102 Question Id : 2501071782 Question Type : MCQ Option Shuffling : Yes Display Question Number : Yes
Single Line Question Option : No Option Orientation : Vertical

Transfer function of a lead compensator is given by $G_c(s) = \frac{s+a}{s+b}$. Find the values of

a, b and maximum compensation of the $G_c(s)$.

Options :

1. $a = 1, b = 2 ; 2 \text{ rad/s}$

2. $a = 3, b = 2 ; 3 \text{ rad/s}$

3. $a = -3, b = -1 ; 6 \text{ rad/s}$

4. $a = 3, b = 1 ; \sqrt{3} \text{ rad/s}$

Question Number : 103 Question Id : 2501071783 Question Type : MCQ Option Shuffling : Yes Display Question Number : Yes
Single Line Question Option : No Option Orientation : Vertical

The system $\frac{900}{s(s+1)(s+9)}$ is to be such that its gain-crossover frequency becomes

same as its uncompensated phase crossover frequency and provides a 45° phase margin. To achieve this, which of the following may be used?

Options :

1. A lag compensator that provides an attenuation of 20 dB and a phase lag of 45° at the frequency of $3\sqrt{3} \text{ rad/s}$

2. A lead compensator that provides an amplification of 20 dB and a phase lead of 45° at the frequency of 3 rad/s

3. A lag-lead compensator that provides an amplification of 20 dB and a phase lag of 45° at the frequency of $\sqrt{3} \text{ rad/s}$

4. A lag-lead compensator that provides an attenuation of 20 dB and phase lead of 45° at the frequency of 3 rad/s

Question Number : 104 Question Id : 2501071784 Question Type : MCQ Option Shuffling : Yes Display Question Number : Yes
Single Line Question Option : No Option Orientation : Vertical

A process in feedback with proportional controller with ultimate gain $K_u = 10$ is oscillating at a frequency of $P_u = 8$ Hz. The Ziegler-Nichols setting for the proportional controller is

Options :

1. 8
2. 5
3. 1.25
4. 10

Question Number : 105 Question Id : 2501071785 Question Type : MCQ Option Shuffling : Yes Display Question Number : Yes
Single Line Question Option : No Option Orientation : Vertical

Consider the following statements for pneumatic and hydraulic control systems:

1. The normal operating pressure of pneumatic control is very much higher than that of hydraulic control.
2. In Pneumatic control, external leakage is permissible to a certain extent, but there should be not leakage in a hydraulic control.

Which of the statements given above is/are correct?

Options :

1. 1 only
2. 2 only
3. Both 1 and 2
4. Neither 1 nor 2

Question Number : 106 Question Id : 2501071786 Question Type : MCQ Option Shuffling : Yes Display Question Number : Yes
Single Line Question Option : No Option Orientation : Vertical

In UV-visible spectrophotometer, what does photo detector measure?

Options :

1. The fraction of light of a particular wavelength absorbed by a sample

2. The fraction of light of a particular wavelength transmitted by a sample

3. The total amount of light energy absorbed by a sample.

4. The intensity of light that emerges from a sample.

Question Number : 107 Question Id : 2501071787 Question Type : MCQ Option Shuffling : Yes Display Question Number : Yes
Single Line Question Option : No Option Orientation : Vertical

The dimensions of electrodes used in conductivity cell are 0.95 cm and 1.015 cm. If the two electrodes are held at a distance of 0.45 cm, calculate the cell constant.

Options :

1. 46.8 m^{-1}

2. 40.8 m^{-1}

3. 42.8 m^{-1}

4. 45.8 m^{-1}

Question Number : 108 Question Id : 2501071788 Question Type : MCQ Option Shuffling : Yes Display Question Number : Yes
Single Line Question Option : No Option Orientation : Vertical

In flame emission spectrometer, the measure of _____ is used for quantitative analysis.

Options :

1. frequency

2. colour

3. velocity

4. intensity

Question Number : 109 Question Id : 2501071789 Question Type : MCQ Option Shuffling : Yes Display Question Number : Yes
Single Line Question Option : No Option Orientation : Vertical

Mass spectrometers are used to determine which of the following?

Options :

1. Composition in sample
2. Concentration of elements in sample
3. Relative mass of atoms
4. Properties of sample

Question Number : 110 Question Id : 2501071790 Question Type : MCQ Option Shuffling : Yes Display Question Number : Yes
Single Line Question Option : No Option Orientation : Vertical

Light of wavelength 630 nm in vacuum, falling normally on a biological specimen of thickness 10 mm, splits into two beams that are polarized at right angles. The refractive index of the tissue for the two polarizations are 1.32 and 1.333. When the two beams emerge, what is the phase difference?

Options :

1. 0.13 deg
2. 74.3 deg
3. 90 deg
4. 128.6 deg

Question Number : 111 Question Id : 2501071791 Question Type : MCQ Option Shuffling : Yes Display Question Number : Yes
Single Line Question Option : No Option Orientation : Vertical

Korotkoff sounds are used in

Options :

1. blood flow measurement

2. blood pressure measurements
3. heart valve functioning
4. as a reference for sound level measurement

Question Number : 112 Question Id : 2501071792 Question Type : MCQ Option Shuffling : Yes Display Question Number : Yes
Single Line Question Option : No Option Orientation : Vertical

Instruments measuring volume changes in part of the body are called

Options :

1. Plethysmographs
2. Ventilators
3. Cardiac pacemakers
4. Defibrillators

Question Number : 113 Question Id : 2501071793 Question Type : MCQ Option Shuffling : Yes Display Question Number : Yes
Single Line Question Option : No Option Orientation : Vertical

Which of the following records brain structure?

Options :

1. EEG
2. EMG
3. ECG
4. MRI

Question Number : 114 Question Id : 2501071794 Question Type : MCQ Option Shuffling : Yes Display Question Number : Yes
Single Line Question Option : No Option Orientation : Vertical

The Treadmill Test is used to diagnose

Options :

1. the balancing style during walk of the patient.

2. the auditory activity of the patient.

3. the visual activity of the patient.

4. the cardiac activity of the patient.

Question Number : 115 Question Id : 2501071795 Question Type : MCQ Option Shuffling : Yes Display Question Number : Yes Single Line Question Option : No Option Orientation : Vertical

Light coming out of an optical fiber is incident on a plane perpendicular to the fiber axis and 50 mm away from the end of the fiber. The light coming out creates a circular spot, of 20 mm diameter. Neglecting the diameter of the fiber, the numerical aperture of the fiber is, approximately

Options :

1. 0.14

2. 0.20

3. 0.34

4. 0.40

Question Number : 116 Question Id : 2501071796 Question Type : MCQ Option Shuffling : Yes Display Question Number : Yes Single Line Question Option : No Option Orientation : Vertical

A standard three-lead frontal plane ECG is taken of a person with a normal heart. The peak amplitude of the R-wave is

Options :

1. greater in lead I

2. greater in lead II

3. greater in lead III
4. equal in all the leads

Question Number : 117 Question Id : 2501071797 Question Type : MCQ Option Shuffling : Yes Display Question Number : Yes
Single Line Question Option : No Option Orientation : Vertical

Which of the following is commonly used to convert the angular position of a shaft in to electric signal?

Options :

1. synchros
2. servomotor
3. stepper motor
4. LVDT

Question Number : 118 Question Id : 2501071798 Question Type : MCQ Option Shuffling : Yes Display Question Number : Yes
Single Line Question Option : No Option Orientation : Vertical

In an electromagnetic blood flowmeter, the induced voltage is directly proportional to the

Options :

1. blood flow rate
2. square root of blood flow rate
3. square of blood flow rate
4. logarithm of the blood flow rate

Question Number : 119 Question Id : 2501071799 Question Type : MCQ Option Shuffling : Yes Display Question Number : Yes
Single Line Question Option : No Option Orientation : Vertical

The relative permittivity of an optical medium is 2.5. Its refractive index is

Options :

1. 0.4
2. 1.25
3. 1.58
4. not possible to calculate

Question Number : 120 Question Id : 2501071800 Question Type : MCQ Option Shuffling : Yes Display Question Number : Yes
Single Line Question Option : No Option Orientation : Vertical

What is the acceptance angle of the fiber when $n_1 = 1.48$ and $n_2 = 1.46$?

Options :

1. 38.07°
2. 28.07°
3. 14.07°
4. 18.07°