

# Eklavya Eklavya 2021

## ONE BOW GURU MANTRA GOAL

Get a Chance to Learn from **India's Best Teachers** & Crack **JEE ADVANCED 2021**

**Vedantu's Eklavya 2021 is a Specialized Program for JEE ADVANCED**, designed and headed by Co-Founder, IIT alumnus and Master Teacher Anand Prakash. Get mentored by **Top JEE Experts**, who have produced JEE Advanced **AIR 1, 2, 4, 7**, & many more.

---

### Anand Prakash

Co-Founder, Vedantu  
IIT- Roorkee



## Our Previous **EKLAVYANs** & Their Achievements

Student Name	Main Rank	Advanced Rank
Chirag Jain	731	41
Prakhar Agrawal	445	177
Tanmay Gangwar	2133	227
Aditya Kukreja	1772	635
Eknor Singh	3574	1243
Aditya Gupta	14275	1326

**547 JEE Advanced Selections in 2020**

**JOIN NOW**



## Study Materials

- [JEE Main & Advanced – Free Study Material](#)
- [NEET UG – Free Study Material](#)
- [NCERT Solutions for Class 1 to 12](#)
- [NCERT Books PDF for Class 1 to 12](#)
- [ICSE & ISC Free Study Material](#)
- [Free Study Material for Kids Learning \(Grade 1 to 5\)](#)
- [Olympiad Free Study Material](#)
- [Reference Books \(RS Aggarwal, RD Sharma, HC Verma, Lakhmir Singh, Exemplar and More\)](#)
- [Previous Year Question Paper CBSE & State Boards](#)
- [Sample Papers](#)
- [Access All Free Study Material Here](#)

## JEE-Main-25-07-2021-Shift-2 (Memory Based)

### PHYSICS

**Question:** A balloon is rising up with constant velocity of 10 m/s. At a height of 75m, a small stone is dropped from it. At what height from the ground would the balloon be, when the mass reaches the ground?

**Answer:** 125 m

**Solution:** Let the stone take time  $t$  in reaching the ground

Initial velocity of stone  $u = +10$  m/s

Acceleration  $= -g = -10$  m/s<sup>2</sup>

Height  $h = -75$  m

$$-75 = 10t - \frac{1}{2} \times 10 \times t^2$$

$$\Rightarrow -15 = 2t - t^2$$

$$\Rightarrow t^2 - 5t + 3t - 15 = 0$$

$$\Rightarrow t = 5 \text{ sec}$$

In this time balloon will move up by  $10 \times 5 = 50$  m

Height of balloon from ground  $75 + 50 = 125$  m

**Question:** For the force equation  $F = A \cos(Bx) + C \sin(Dt)$ . Find dimensions of  $\frac{AD}{B}$ ?

**Options:**

(a)  $M^1 T^{-1}$

(b)  $M^1 L^2 T^{-3}$

(c)  $M^1 T^3$

(d)  $M^1 T^{-3}$

**Answer:** (b)

**Solution:**  $F = A \cos(Bx) + C \sin(Dt)$

$Bx$  and  $Dt$  will be dimensionless

$$\text{So, } [B] = \frac{1}{[x]} = [M^0 L^{-1} T^0] \text{ and } [D] = \frac{1}{[t]} = [M^0 L^0 T^{-1}]$$

As cos and sin function is dimensionless, so A and C will have dimensions of force

$$[A] = [C] = [MLT^{-2}]$$

$$\left[ \frac{AD}{B} \right] = \frac{[MLT^{-2}][M^0L^0T^{-1}]}{[M^0L^{-1}T^0]}$$

$$= [ML^2T^{-3}]$$

**Question:** A particle starts from rest with acceleration  $a = \alpha t + \beta t^2$  where  $\alpha$  and  $\beta$  are constant. Find its displacement between  $t = 1$  and  $t = 2$  seconds.

**Options:**

(a)  $\frac{7\alpha}{3} + \frac{5\beta}{4}$

(b)  $\frac{7\alpha}{6} + \frac{5\beta}{4}$

(c)  $7\alpha + 5\beta$

(d) None

**Answer:** (b)

**Solution:**

Given,  $a = \alpha t + \beta t^2$

$$\Rightarrow \frac{dv}{dt} = \alpha t + \beta t^2$$

$$\Rightarrow \int dv = \int \alpha t dt + \int \beta t^2 dt$$

$$\Rightarrow v = \frac{\alpha t^2}{2} + \frac{\beta t^3}{3} + c$$

At  $t = 0, v = 0$

$$\Rightarrow 0 = 0 + 0 + c$$

$$\Rightarrow c = 0$$

$$v = \frac{dx}{dt} = \frac{\alpha t^2}{2} + \frac{\beta t^3}{3}$$

$$\int_{x_1}^{x_2} dx = \int_1^2 \frac{\alpha t^2}{2} dt + \int_1^2 \frac{\beta t^3}{3} dt$$

$$x_2 - x_1 = \left[ \frac{\alpha t^3}{6} \right]_1^2 + \left[ \frac{\beta t^4}{12} \right]_1^2$$

$$\Delta x = \frac{8\alpha}{6} - \frac{\alpha}{6} + \frac{16\beta}{12} - \frac{\beta}{12}$$

$$\Delta x = \frac{7\alpha}{6} + \frac{15\beta}{12}$$

$$\Delta x = \frac{7\alpha}{6} + \frac{5\beta}{4}$$

**Question:** If velocity of photon is  $C$  and that of electron is  $v$ , then find the ratio of KE of electron to photon if their de-Broglie wavelength is same.

**Options:**

(a)  $\frac{C}{v}$

(b)  $\frac{2C}{v}$

(c)  $\frac{v}{2C}$

(d)  $\frac{v}{C}$

**Answer:** (c)

**Solution:** Given,  $\lambda_{ph} = \lambda_e$

$$\lambda_e = \frac{h}{mv} \dots (i)$$

$$\text{Kinetic energy of photon} = \frac{hC}{\lambda_{ph}} = \frac{hC}{\lambda_e} \dots (ii)$$

$$\text{Kinetic energy of electron} = \frac{(mv)^2}{2m} = \frac{h^2}{\lambda_e^2 (2m)} \dots (iii)$$

$$\frac{(K.E.)_{ph}}{(K.E.)_e} = \frac{hC}{\lambda_e} \times \frac{\lambda_e^2 (2m)}{h^2}$$

$$= \frac{\lambda_e (2m)C}{h}$$

From eq. (i)

$$= \frac{2mC}{mv} = \frac{2C}{v}$$

$$\Rightarrow \frac{(K.E.)_E}{(K.E.)_{Ph}} = \frac{v}{2C}$$

**Question:** Two soap bubbles of radius  $R_1$  and  $R_2$  combine isothermally to form a new soap bubble. Find the radius of the new soap bubble formed

**Options:**

(a)  $\frac{R_1 + R_2}{2}$

(b)  $\sqrt{R_1 R_2}$

(c)  $\frac{R_1 R_2}{R_1 + R_2}$

(d)  $\sqrt{R_1^2 + R_2^2}$

**Answer:** (d)

**Solution:** Radius of first soap bubble is  $R_1$

Radius of first soap bubble is  $R_2$

Let,  $P_1 = \frac{4T}{R_1}$ ,  $V_1 = \frac{4}{3} \pi R_1^3$ , be the excess pressure inside first soap bubble and volume of first soap bubble respectively.

$P_2 = \frac{4T}{R_2}$ ,  $V_2 = \frac{4}{3} \pi R_2^3$  be the excess pressure inside second soap bubble and volume of second soap bubble respectively.

$P = \frac{4T}{R}$ ,  $V = \frac{4}{3} \pi R^3$  be the excess pressure inside new soap bubble, volume and radius of new soap bubble respectively.

The two bubbles combine isothermally, hence

$$PV = P_1V_1 + P_2V_2$$

$$\frac{4T}{R} \left( \frac{4}{3} \pi R^3 \right) = \frac{4T}{R_1} \left( \frac{4}{3} \pi R_1^3 \right) + \frac{4T}{R_2} \left( \frac{4}{3} \pi R_2^3 \right)$$

$$R^2 = R_1^2 + R_2^2$$

$$R = \sqrt{R_1^2 + R_2^2}$$

**Question:** Two dipoles  $p_1$  and  $p_2$  are perpendicular to each other, are placed in a uniform magnetic field such that  $p_1$  makes an angle of  $37^\circ$  with field. Both dipoles experiences same torque. Find ratio of their dipole moment.

**Options:**

(a)  $\frac{4}{3}$

(b)  $\frac{3}{4}$

(c)  $\frac{3}{5}$

(d)  $\frac{4}{5}$

**Answer:** (a)

**Solution:**

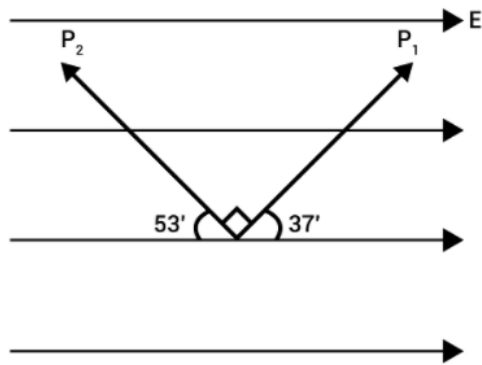

$$\text{Torque} = \vec{P} \times \vec{E} = PE \sin \theta$$

$$\text{Torque on dipole one } \tau_1 = P_1 \times E$$

$$= P_1 E \sin 37^\circ$$

$$= P_1 E \times \frac{3}{5}$$

$$\text{Similarly } \tau_2 = P_2 \times E$$

$$= P_2 E \sin (90 + 37^\circ)$$

$$= P_2 E \cos 37^\circ$$

$$= P_2 E \left( \frac{4}{5} \right)$$

$$\tau_1 = \tau_2$$

$$P_1 E \times \frac{3}{5} = P_2 E \frac{4}{5}$$

$$\frac{P_1}{P_2} = \frac{4}{3}$$

**Question:** If  $\vec{X}$  and  $\vec{Y}$  are two vectors, such that  $|\vec{X}| = |\vec{Y}|$  &  $|\vec{X} - \vec{Y}| = 10|\vec{X} + \vec{Y}|$ , then. Find the angle between  $\vec{X}$  and  $\vec{Y}$

**Options:**



(a)  $\cos^{-1}\left(\frac{-7}{99}\right)$

(b)  $\cos^{-1}\left(\frac{-99}{101}\right)$

(c)  $\sin^{-1}\left(\frac{-99}{101}\right)$

(d)  $\sin^{-1}\left(\frac{-7}{99}\right)$

**Answer:** (b)

**Solution:**  $|\vec{X}| = |\vec{Y}| = A$

$$|\vec{X} - \vec{Y}| = 10|\vec{X} + \vec{Y}|$$

$$X^2 + Y^2 - 2XY \cos \theta = 100(X^2 + Y^2 + 2XY \cos \theta)$$

$$A^2 + A^2 - 2A^2 \cos \theta = 100(A^2 + A^2 + 2A^2 \cos \theta)$$

$$2A^2 - 2A^2 \cos \theta = 200A^2 + 200A^2 \cos \theta$$

$$198A^2 = -202A^2 \cos \theta$$

$$\cos \theta = \frac{-99}{101}$$

$$\theta = \cos^{-1}\left(\frac{-99}{101}\right)$$

**Question:** A disc of radius 2 metres and mass M, is rotating with 200 rpm. Find the torque required to stop the disc in 10 seconds.

**Options:**

(a)  $\frac{4\pi M}{3}$  SI units

(b)  $\frac{2\pi M}{3}$  SI units

(c)  $\frac{\pi M}{3}$  SI units

(d)  $\frac{8\pi M}{3}$  SI units

**Answer:** (a)

**Solution:**

R = 2 m,      mass = M

$$\omega_0 = 200 \text{ rpm} = 200 \times \frac{\pi}{30} = \frac{20\pi}{3} \text{ rad/sec}$$

$$\omega = 0$$

$$t = 10 \text{ sec}$$

$$\omega = \omega_0 + \alpha t$$

$$0 = \frac{20\pi}{3} + \alpha(10)$$

$$\alpha = -\frac{2\pi}{3}$$

$$\text{Torque}(\tau) = I\alpha; I = \frac{MR^2}{2} = 2M$$

$$= \frac{4\pi M}{3} \text{ units}$$

**Question:** A wire of 16 ohms is bent to form a square. Now a cell of 9 volt and internal resistance  $1\Omega$  is connected across one of the sides. Find the potential difference across the diagram of the square.

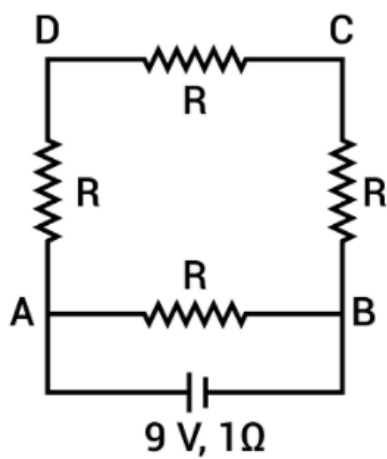

**Options:**

- (a) 8 V
- (b) 5.5 V
- (c) 6.75 V
- (d) 3.5 V

**Answer:** (c)

**Solution:**

$$R = 16\Omega$$

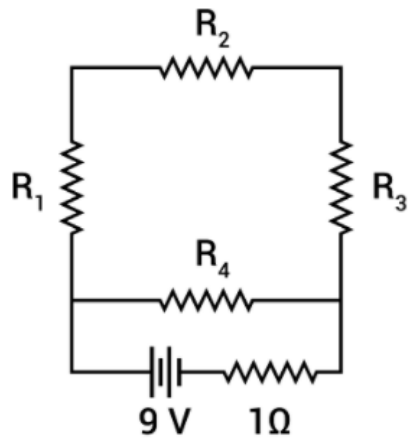

$$R_1 = R_2 = R_3 = R_4 = 4\Omega$$

$$R_{eq} = 3\Omega + 1\Omega = 4\Omega$$

$$R_{eq} = 4\Omega$$

Using ohm's law,  $V = IR$

$$9 = I \times 4$$

$$I = \frac{9}{4} \text{ A}$$

$I$  is the total current flowing across circuit voltage across internal resistance =  $IR'$

$$= \frac{9}{4} \times 1 = \frac{9}{4} \text{ V}$$

$$\text{Voltage across square diagram} = 9 - \frac{9}{4}$$

$$= 6.75 \text{ V}$$

**Question:** If  $\delta_{\min}$  is the minimum deviation through a prism and  $\mu$  is refractive index and  $A$  is angle of prism, then

**Options:**

$$(a) \mu = \frac{\sin(\delta_{\min})}{\sin\left(\frac{A}{2}\right)}$$

$$(b) \mu = \frac{\sin\left(\frac{A + \delta_{\min}}{2}\right)}{\sin\left(\frac{A}{2}\right)}$$

$$(c) \mu = \frac{\sin\left(\frac{A}{2}\right)}{\sin\left(\frac{A + \delta_{\min}}{2}\right)}$$

(d) None of these

**Answer:** (b)

**Solution:**

Formula for refractive index of prism.

$$\mu = \frac{\sin\left(\frac{A + \delta_{\min}}{2}\right)}{\sin\left(\frac{A}{2}\right)}$$

**Question:** A radioactive nucleus decays so that after 30 years, only  $\frac{1}{8}$ <sup>th</sup> of the initial sample is

active. What is the half life of sample?

**Options:**

- (a) 20 years
- (b) 10 years
- (c) 40 years
- (d) 5 years

**Answer:** (b)

**Solution:**

$\frac{1}{8}$ <sup>th</sup> of the initial samples is active after 30 days.

$$\text{So, } \frac{1}{8} = \left(\frac{1}{2}\right)^3$$

i.e., it required 3 half life for this.

3 half life = 30 days.

So, 1 half life = 10 days

**Question:** For an amplitude modulated wave, message signal peak voltage = 20 V, carrier signal peak voltage = 20 V. What is the modulation index?

**Options:**

- (a) 50%
- (b) 200%
- (c) 0%
- (d) 100%

**Answer:** (d)

**Solution:**

$$\text{Modulation index} = \frac{\text{Peak value of modulating signal}}{\text{Peak value of carrier signal}}$$

$$= \frac{20}{20} = 1$$

$$\% \text{ Modulation} = 1 \times 100 = 100\%$$

**Question:** Two charges of equal magnitude are thrown with speeds ratio (3 : 2) perpendicular to the magnetic field. If their masses are in the ratio of 1 : 2. Find ratio of the radii?

**Options:**

(a)  $\frac{4}{3}$

(b)  $\frac{3}{4}$

(c)  $\frac{1}{3}$

(d) 3

**Answer:** (b)

**Solution:**

$$R = \frac{mv}{qB} \text{ (charges are equal)}$$

$$R_1 = \frac{m_1 v_1}{qB}$$

$$R_2 = \frac{m_2 v_2}{qB}$$

$$\frac{R_1}{R_2} = \frac{m_1}{m_2} \times \frac{v_1}{v_2}$$

$$\frac{R_1}{R_2} = \frac{1}{2} \times \frac{3}{2} \quad \left[ \because \frac{m_1}{m_2} = \frac{1}{2} \text{ and } \frac{v_1}{v_2} = \frac{3}{2} \right]$$

$$\frac{R_1}{R_2} = \frac{3}{4}$$

**Question:** For a certain incident wavelength on a metal surface, the max KE of the photoelectron is 4.8 eV. If the incident wavelength is doubled, then the max KE changes to 1.6 eV. Then find the threshold wavelength for the metal surface.

**Options:**

(a) 7750 nm

(b) 775 nm

(c) 77.5 nm

(d) can't be determined

**Answer:** (b)

**Solution:**

$$KE_{\max} = \frac{hc}{\lambda} - \phi$$

$$KE_{\max 1} = 4.8\text{ev} = \frac{hc}{\lambda} - \phi \dots (1)$$

$$KE_{\max 2} = 1.6\text{ev} = \frac{hc}{2\lambda} - \phi \dots (2)$$

Multiply equation (2) by 2

$$1.6 \times 2\text{ev} = \frac{hc}{\lambda} - 2\phi \dots (3)$$

eq (1) – eq (3) we get

$$1.6\text{ev} = \phi$$

So,

$$\phi = \frac{hc}{\lambda_0} = 1.6$$

$$\lambda_0 = \frac{1240}{1.6} \text{nm} = 775\text{nm}$$

**Question:** The efficiency of heat engine is  $\frac{1}{6}$ . When the temperature of sink is reduced by

$62^\circ\text{C}$ , then efficiency doubles. What is the temperature of the source?

**Answer:** ( $T_1 = 372\text{K}$ )

**Solution:**

Given,

$$\frac{1}{6} = 1 - \frac{T_{\text{sink}}}{T_{\text{source}}}$$

$$\Rightarrow \frac{T_{\text{sink}}}{T_{\text{source}}} = \frac{5}{6}$$

Also,

$$\frac{2}{6} = 1 - \frac{T_{\text{sink}} - 62}{T_{\text{source}}}$$

$$\Rightarrow \frac{62}{T_{\text{source}}} = \frac{1}{6}$$

$$\therefore T_{\text{source}} = 372\text{K}$$

**Question:** Two particles having identical masses and charges  $2Q$  and  $Q$  are moving with velocities  $V$  and  $2V$  respectively, In uniform magnetic field  $B$ . Find ratio of the radius of circle describe by them

**Options:**

(a)  $\frac{1}{2}$

(b)  $2 : 1$

(c)  $\frac{1}{4}$

(d) 4 : 1

**Answer:** (c)

**Solution:**

$$\frac{mV^2}{R} = qVB$$

$$\Rightarrow R = \frac{mV}{qB}$$

$$\Rightarrow \frac{R_1}{R_2} = \frac{Q}{2Q} \times \frac{V}{2V} = \frac{1}{4}$$

**Question:** A force  $(5y + 4)\hat{j}$  displaces a particle from  $y = 0$  to  $y = 2$ . Find work done by force.

**Options:**

(a) 16 J

(b) 18 J

(c) 20 J

(d) 22 J

**Answer:** (b)

**Solution:**

$$w \cdot d = \int_0^2 Fy \cdot dy$$

$$= \int_0^2 (5y + 4) dy$$

$$= \left[ \frac{5y^2}{2} + 4y \right]_0^2$$

$$= 18J$$

**Question:** In an AC circuit having resistance of  $10\Omega$ , find the time taken by current to reach RMS value from maximum value. Frequency and RMS voltage of the source is 50 Hz and 220 V respectively.

**Options:**

(a) 2.5 msec

(b) 5 msec

(c) 10 msec

(d) 1 msec

**Answer:** (a)

**Solution:**

$$V_{rms} = \frac{V_{peak}}{\sqrt{2}}$$

$$V = V_{peak} \sin\left(\omega t + \frac{\pi}{2}\right)$$

$$[\because \text{at } t = 0 \quad V = V_{peak}]$$

For  $V_{rms}$ ,

$$\Rightarrow \frac{V_{peak}}{\sqrt{2}} = V_{peak} \cos \omega t$$

$$\Rightarrow \cos \omega t = \frac{1}{\sqrt{2}}$$

$$\omega t = \frac{\pi}{4}$$

$$\Rightarrow (2\pi f)t = \frac{\pi}{4}$$

$$\Rightarrow t = \frac{1}{8f} = 2.5ms.$$

**Question:** For both the given circuits, average power dissipated is same. Find  $\omega$  of the second circuit.

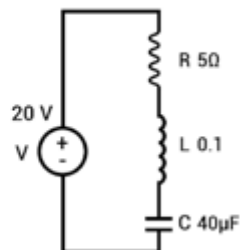
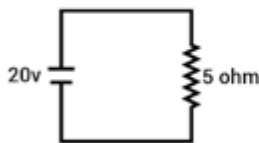

**Options:**

- (a) 1000 rad/sec
- (b) 500 rad/sec
- (c) 100 rad/sec
- (d) 5000 rad/sec

**Answer:** (b)

**Solution:**

For left circuit,

$$P = 20 \times \frac{20}{5} = 80w,$$

For right circuit,

$$P = 20 \times \frac{20}{Z} \times \frac{R}{Z}$$

$$Z = \sqrt{R^2 + (X_L - X_C)^2}$$



Equating

$$80 = \frac{400R}{Z^2}$$

$$Z^2 = \frac{400 \times 5}{80}$$

$$\Rightarrow Z = 5$$

$R = Z$  (Resonance)

$$\Rightarrow w = \frac{1}{\sqrt{LC}}$$

$$= \frac{1}{\sqrt{0.1 \times 40 \times 10^{-6}}}$$

$$= 500 \text{ rad / s}$$



## JEE-Main-25-07-2021-Shift-2 (Memory Based)

### CHEMISTRY

**Question:** What is the correct structure of cytosine

**Solution:**

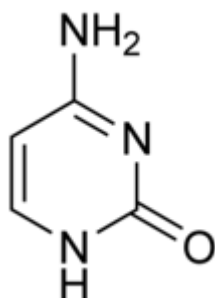

**Question:** Which of the following form interstitial hydride easily?

**Options:**

- (a) Cr
- (b) Fe
- (c) Mn
- (d) Co

**Answer: (a)**

**Solution:** These are formed by many d-block and f-block elements. However, the metals of group 7, 8 and 9 do not form hydride. Even from group 6, only chromium forms CrH.

**Question:** Increasing order of Bond order of :  $O_2$  ,  $O_2^+$  ,  $O_2^-$  ,  $O_2^{2-}$

**Options:**

- (a)  $O_2^+ > O_2 > O_2^- > O_2^{2-}$
- (b)  $O_2 > O_2^+ > O_2^- > O_2^{2-}$
- (c)  $O_2^- > O_2 > O_2^+ > O_2^{2-}$
- (d)  $O_2^{2-} > O_2 > O_2^+ > O_2^-$

**Answer: (a)**

**Solution:**

Bond order

	$O_2^+$	$O_2$	$O_2^-$	$O_2^{2-}$
No. of electron	15	16	17	18
	2.5	2	1.5	1

Bond order  $O_2^+ > O_2 > O_2^- > O_2^{2-}$

**Question:** If work done by system is 200 J and heat absorbed is 150 then what is change in internal energy?

**Options:**

- (a) +50 J
- (b) -50 J
- (c) 350 J
- (d) -350 J

**Answer: (b)**

**Solution:**

$$W = -200 \text{ J}$$

$$q = + 150 \text{ J}$$

$$\Delta U = q + w$$

$$\Delta U = 150 - 200 = -50 \text{ J}$$

**Question:** Number of electrons in 4f orbitals of  $\text{Ho}^{3+}$  ( $Z = 67$ )

**Options:**

- (a) 10
- (b) 12
- (c) 11
- (d) 9

**Answer: (a)**

**Solution:**

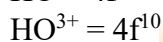
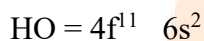

**Question:** Match the column

Column I	Column II
(i) Clouds	(P) Gel
(ii) Pumice stone	(Q) Aerosols
(iii) Cheese	(R) Solid foam
(iv) Shaving cream	(S) Emulsion

**Options:**

- (a) (i)  $\rightarrow$  Q, (ii)  $\rightarrow$  R, (iii)  $\rightarrow$  P, (iv)  $\rightarrow$  S
- (b) (i)  $\rightarrow$  S, (ii)  $\rightarrow$  R, (iii)  $\rightarrow$  Q, (iv)  $\rightarrow$  P
- (c) (i)  $\rightarrow$  P, (ii)  $\rightarrow$  Q, (iii)  $\rightarrow$  S, (iv)  $\rightarrow$  R
- (d) (i)  $\rightarrow$  R, (ii)  $\rightarrow$  S, (iii)  $\rightarrow$  P, (iv)  $\rightarrow$  Q

**Answer: (a)**

**Solution:**

Column I	Column II
(i) Clouds	(Q) Aerosols
(ii) Pumice stone	(R) Solid foam
(iii) Cheese	(P) Gel
(iv) Shaving cream	(S) Emulsion

**Question:** S1 : Chlorofluorocarbon react in the visible range and Cl radical is formed

S2:  $\text{O}_3$  react with nitric acid to form nitrogen and oxygen

**Options:**

- (a) S1 is true and S2 is false
- (b) S1 is false, S2 is true

- (c) Both Statements are true  
(d) Both statements are false

**Answer: (d)**

**Solution:**

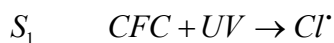

S<sub>1</sub> wrong

S<sub>2</sub> wrong

**Question:** Biodegradable polyamide is formed by which of these two reactant?

**Options:**

- (a) Glycine, amino caproic acid  
(b) Vinyl chloride, glycine  
(c) Glucose, adipic acid  
(d) Adipic acid, Hexamethylenediamine

**Answer: (a)**

**Solution:** Nylon 2-nylon 6

It is an alternating polyamide copolymer of glycine (H<sub>2</sub>N-CH<sub>2</sub>-COOH) and amino caproic acid [H<sub>2</sub>N (CH<sub>2</sub>)<sub>5</sub> COOH] and is biodegradable.

**Question:** Match the column

Column I	Column II
(i) Froth floatation method	P. Sulphide ore
(ii) Reverberatory furnace	Q. Pig iron
(iii) Blast furnace	R. Ag
(iv) Leaching	S. Blister Copper

**Options:**

- (a) (i) → Q, (ii) → R, (iii) → P, (iv) → S  
(b) (i) → S, (ii) → R, (iii) → Q, (iv) → P  
(c) (i) → P, (ii) → S, (iii) → Q, (iv) → R  
(d) (i) → R, (ii) → S, (iii) → P, (iv) → Q

**Answer: (c)**

**Solution:**

Column I	Column II
(i) Froth floatation method	P. Sulphide ore
(ii) Reverberatory furnace	S. Blister Copper
(iii) Blast furnace	Q. Pig iron
(iv) Leaching	R. Ag

**Question:** maleic anhydride can be prepared by

**Options:**

- (a) Heating trans but-2-en-1,4-dioic acid
- (b) treating trans but-2-en-1, 4-dioic acid with alcohol and acid
- (c) treating cis but-2-en-1 4-dioic acid with alcohol and acid
- (d) Heating cis but-2-en-1, 4-dioic acid

**Answer: (d)**

**Solution:**

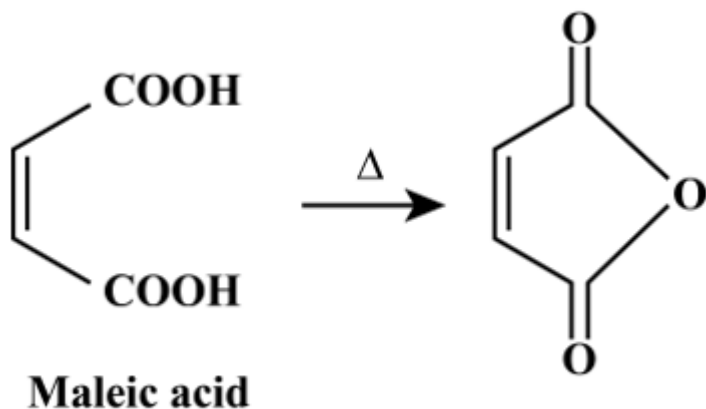

**Question:** A  $\rightarrow$  B. In this reaction concentration of change B changes by 0.2 in 30 minutes. Find the average rate of the reaction in moles per litre hour

**Answer: 0.4**

**Solution:**

$$\text{Rate} = \frac{\Delta C}{\Delta t} = \frac{0.2}{0.5}$$

$$\Delta t = \frac{30}{60} = 0.5$$

$$= 0.4 \text{ mol / lit}^{-1}, \text{Hr}^{-1}$$

**Question:**  $[\text{Ba}(\text{OH})_2] = 5 \times 10^{-3}$ , It dissociates completely, Find the conc of  $\text{H}_3\text{O}^+$

**Options:**

- (a)  $10^{-12} \text{ M}$
- (b)  $10^{-10} \text{ M}$
- (c)  $10^{-11} \text{ M}$
- (d)  $2 \times 10^{-10} \text{ M}$

**Answer: (a)**

**Solution:**

$$[\text{OH}^-] = 2 \times 5 \times 10^{-3}$$

$$[\text{OH}^-] = 10^{-2} \text{ M}$$

$$[\text{H}^+][\text{OH}^-] = 10^{-14}$$

$$[\text{H}^+] = \frac{10^{-14}}{10^{-2}}$$

$$[\text{H}^+] = 10^{-12}$$

**Question:** Which reaction oxidation state gets changed by +5

**Options:**

- (a)  $\text{C}_2\text{O}_4^{2-}$  to  $\text{CO}_2$
- (b)  $\text{MnO}_4^-$  to  $\text{Mn}^{2+}$
- (c)  $\text{Cr}_2\text{O}_7^{2-}$  to  $\text{Cr}^{3+}$
- (d)  $\text{CrO}_4^{2-}$  to  $\text{Cr}^{3+}$

**Answer: (b)**

**Solution:**

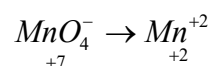

Change by 5

**Question:** Find magnetic moments for  $\text{Sc}^{3+}$ ,  $\text{V}^{2+}$ ,  $\text{Ti}^{2+}$

**Options:**

- (a) 0, 2.8, 1
- (b) 1.5, 0, 2.8
- (c) 0, 3.9, 2.8
- (d) 1, 2.7, 3.9

**Answer: (c)**

**Solution:**

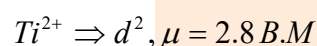
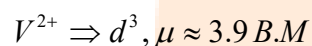
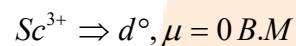

**Question:** Maximum canonical form with 1 pi bond

**Options:**

- (a)  $\text{CO}_3^{2-}$
- (b)  $\text{SO}_3$
- (c)  $\text{SO}_3$
- (d)  $\text{O}_2$

**Answer: (a)**

**Solution:**

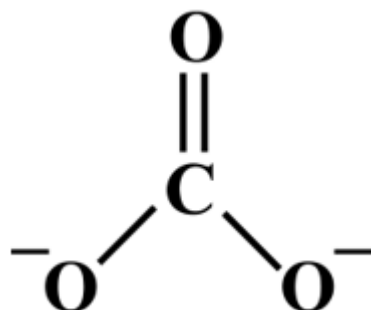

**Question:** In Kjeldahl method, 0.8 g of organic compound is used . % of nitrogen come out to be 46% . the \_\_\_ ml of 1 M  $\text{H}_2\text{SO}_4$  used to neutralize  $\text{NH}_3$

**Options:**

- (a) 15.20 mL
- (b) 13.14 mL
- (c) 12.00 mL
- (d) 7.80 mL

**Answer: (b)**

**Solution:**

$$\%N = \frac{1.4 \times N \times V}{w}$$

$$46 = \frac{1.4 \times 2 \times V}{0.8}$$

$$V = 13.14 \text{ mL}$$

**Question:** Arrange the following in increasing density order:

**Options:**

- (a) Benzene
- (b) Chlorobenzene
- (c) 1,3 chlorobenzene
- (d) 1-bromo-3-chlorobenzene

**Answer: (d)**

**Solution:**

Density  $\propto$  mass

Benzene < chlorobenzene < 1,3 dichlorobenzene < 1 Bromo 3 chlorobenzene

**Question:** Which compound is most stable?

**Options:**

- (a)  $[\text{Co}(\text{en})_2(\text{NH}_3)_2]\text{Cl}_2$
- (b)  $[\text{Co}(\text{en})(\text{NH}_3)_4]\text{Cl}_2$
- (c)  $[\text{Co}(\text{en})_3]\text{Cl}_2$
- (d)  $[\text{Co}(\text{NH}_3)_6]\text{Cl}_2$

**Answer: (c)**

**Solution:**

$[\text{Co}(\text{en})_3]\text{Cl}_2$  chelation

Ligands form more stable complexes.

**Question:**

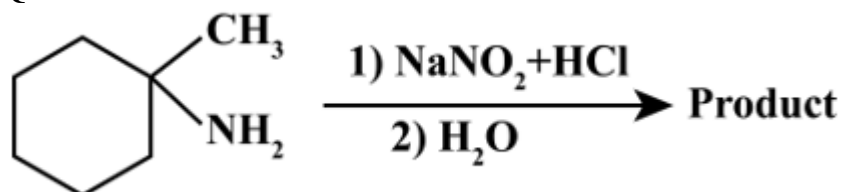

**Options:**

- (a)

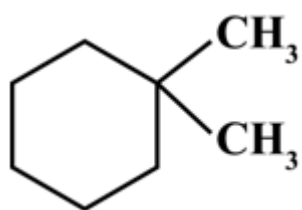

(b)

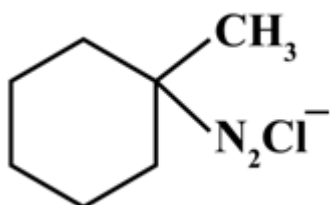

(c)

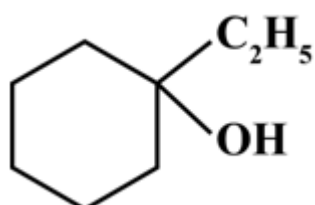

(d)

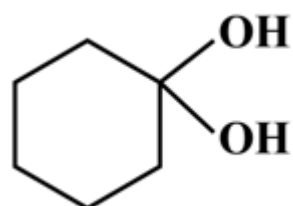

Answer: (c)

Solution:

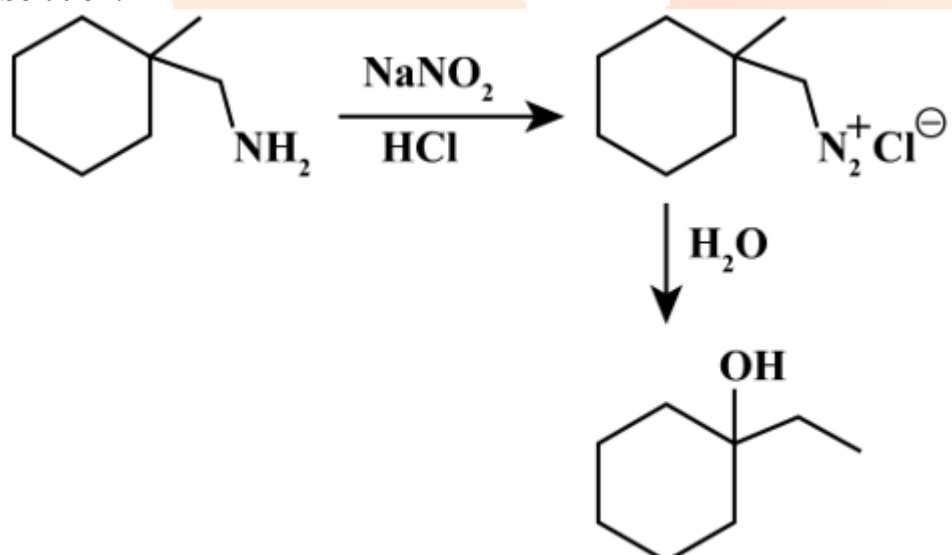

**Question:** Most acidic amongst these is:

**Options:**

- (a) toluene
- (b) butane



- (c) cyclopropene  
(d) cyclopentadiene

**Answer: (d)**

**Solution:**

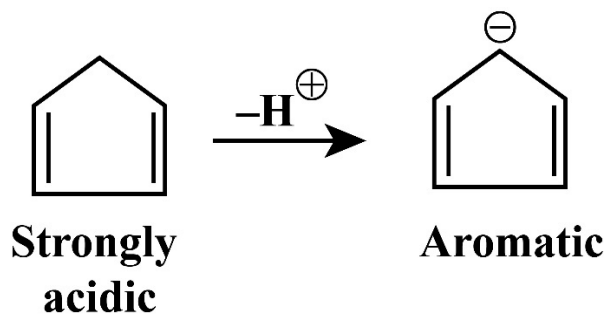

**Question:** Y + aniline reacts to give yellow dye. Find structure of yellow dye

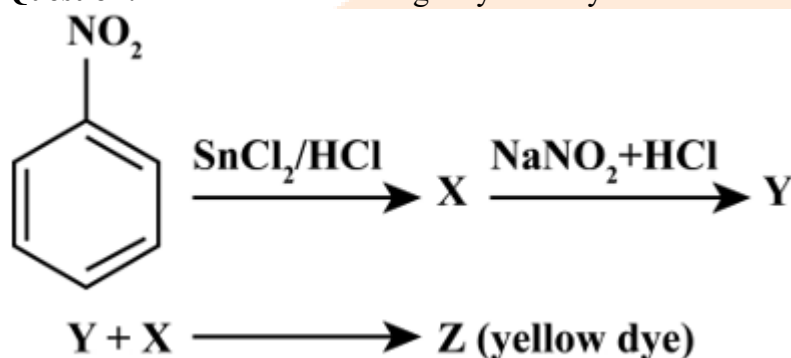

Identify Z

**Options:**

(a)

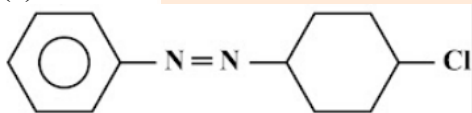

(b)

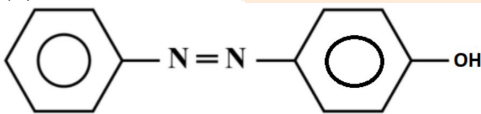

(c)

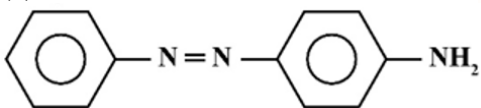

(d)

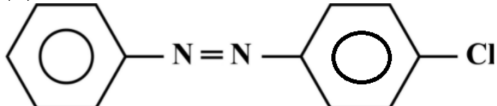

**Answer: (c)**

**Solution:**

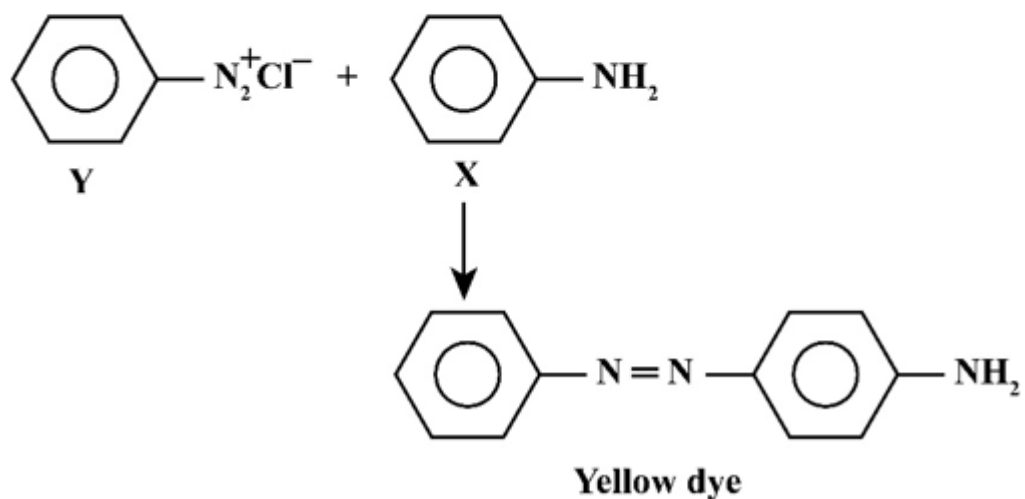
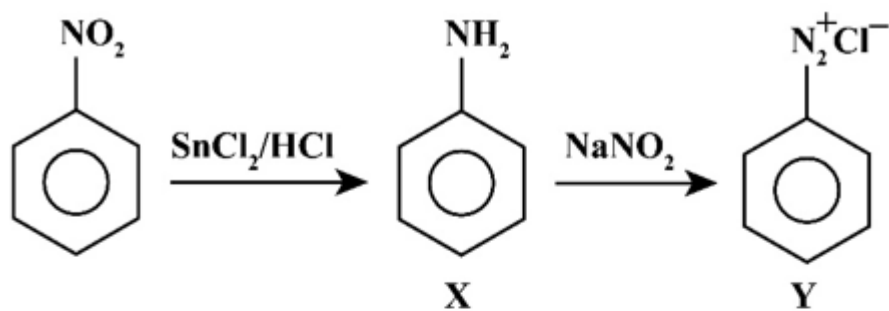

Question:

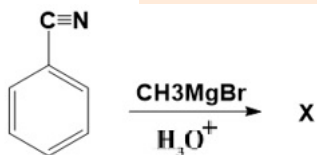

X shows

Options:

- (a) Ninhydrin test
- (b) Iodoform
- (c) Tollen's test
- (d) Fehling's test

Answer: (b)

Solution:

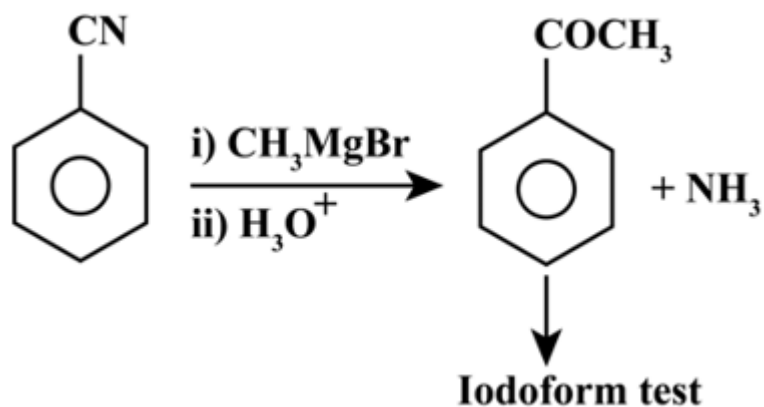

**Question:** Match the column

Column I	Column II
(i) Li	P. Bicarbonate used in Fire extinguisher
(ii) Cs	Q. element in fluid of cell
(iii) Na	R. Carbonate that disintegrate
(iv) K	S. Forma unstable compound with I <sup>-</sup>

**Options:**

- (a) (i) → Q, (ii) → R, (iii) → P, (iv) → S  
 (b) (i) → R, (ii) → S, (iii) → P, (iv) → Q  
 (c) (i) → P, (ii) → S, (iii) → Q, (iv) → R  
 (d) (i) → R, (ii) → S, (iii) → P, (iv) → Q

**Answer: (b)**

**Solution:**

Column I	Column II
(i) Li	R. Bicarbonate used in Fire extinguisher
(ii) Cs	S. element in fluid of cell
(iii) Na	P. Carbonate that disintegrate
(iv) K	Q. Forma unstable compound with I <sup>-</sup>

## JEE-Main-25-07-2021-Shift-2 (Memory Based)

### MATHEMATICS

**Question:** Real solution of  $x^2 - |x| - 12 = 0$

**Options:**

- (a) 1
- (b) 2
- (c) 3
- (d) 4

**Answer:** (b)

**Solution:**

$$(|x| - 4)(|x| + 3) = 0 \Rightarrow |x| = 4 \Rightarrow x = \pm 4$$

Number of real solution is 2

**Question:** If  ${}^n P_r = {}^n P_{r+1}$ ,  ${}^n C_r = {}^n C_{r-1}$ . Find  $r$

**Options:**

- (a)
- (b) 2
- (c)
- (d)  $r - 1$

**Answer:** (b)

**Solution:**

$${}^n P_r = {}^n P_{r+1} \Rightarrow \frac{n!}{(n-r)!} = \frac{n!}{(n-r-1)!} \Rightarrow n-r=1$$

$${}^n C_r = {}^n C_{r-1} \Rightarrow \frac{n!}{r! \cdot (n-r)!} = \frac{n!}{(r-1)! \cdot (n-r+1)!}$$

$$r = n - r + 1 \Rightarrow 2r = 1 + 1 + r \Rightarrow r = 2$$

**Question:**  $y = p(x)$  &  $y = q(x)$  are lines can be written as  $(y - p_x)(y - q_x) = 0$ , then find angle bisector of  $x^2 - 4xy - 5y^2 = 0$

**Options:**

- (a)  $x^2 + 3xy - y^2 = 0$
- (b)
- (c)
- (d)

**Answer:** (a)

**Solution:**

Equation of angle bisector is  $\frac{x^2 - y^2}{xy} = \frac{a - b}{h}$

$$\Rightarrow \frac{x^2 - y^2}{xy} = \frac{6}{-2} = -3$$

$$\Rightarrow x^2 + 3xy - y^2 = 0$$

**Question:** If  $f(x) = \begin{cases} 5x+1, & x < 2 \\ \int_0^n (5+|1-t|) dt, & x \geq 2 \end{cases}$

**Options:**

- (a)  $f(x)$  is differentiable  $\forall x \in R$
- (b)  $f(x)$  is continuous at  $x = 2$  but not differentiable at  $x = 2$
- (c)  $f(x)$  is continuous at  $x = 2$  but not differentiable at  $x = 1$
- (d)

**Answer:** (b)

**Solution:**

$$f(x) = \begin{cases} 5x+1, & x < 2 \\ \int_0^n (5+|1-t|) dt, & x \geq 2 \end{cases}$$

$$f(2^+) = \int_0^1 (6-t) dt + \int_1^x (t+4) dt$$

$$f(2^+) = \frac{11}{2} + \left( \frac{t^2}{2} + 4t \right)_1^x = \frac{11}{2} + \frac{x^2}{2} + 4x - \frac{1}{2} - 4$$

$$f(2^+) = \frac{x^2}{2} + 4x + 1$$

$$f(2^-) = f(2^+) = 11 \text{ (continuous)}$$

$$f'(2^-) = 5, f'(2^+) = 6 \text{ (not differentiable)}$$

**Question:**  $\int_{-1}^1 \log(x + \sqrt{x^2 + 1}) dx$

**Answer:** 0.00

**Solution:**

$$I = \int_{-1}^1 \log(x + \sqrt{x^2 + 1}) dx = \int_{-1}^1 \log(-x + \sqrt{x^2 + 1}) dx$$

$$2I = \int_{-1}^1 \log 1 dx$$

$$\Rightarrow I = 0$$

**Question:** If  $P = \begin{bmatrix} 1 & 0 \\ \frac{1}{2} & 1 \end{bmatrix}$  then  $P^{50} = ?$

**Answer:**

**Solution:**

$$P = \begin{bmatrix} 1 & 0 \\ \frac{1}{2} & 1 \end{bmatrix}$$

$$P^2 = \begin{bmatrix} 1 & 0 \\ \frac{1}{2} & 1 \end{bmatrix} \begin{bmatrix} 1 & 0 \\ \frac{1}{2} & 1 \end{bmatrix} = \begin{bmatrix} 1 & 0 \\ 1 & 1 \end{bmatrix}$$

$$P^3 = \begin{bmatrix} 1 & 0 \\ 1 & 1 \end{bmatrix} \begin{bmatrix} 1 & 0 \\ \frac{1}{2} & 1 \end{bmatrix} = \begin{bmatrix} 1 & 0 \\ \frac{3}{2} & 1 \end{bmatrix}$$

$$\therefore P^n = \begin{bmatrix} 1 & 0 \\ \frac{n}{2} & 1 \end{bmatrix} \Rightarrow P^{50} = \begin{bmatrix} 1 & 0 \\ 25 & 1 \end{bmatrix}$$

**Question:** If  $|\vec{a}| = 2$ ,  $|\vec{b}| = 5$ ,  $|\vec{a} \times \vec{b}| = 8$ , then  $|\vec{a} \cdot \vec{b}| = ?$

**Answer:** 6.00

**Solution:**

$$|\vec{a} \times \vec{b}| = |\vec{a}| |\vec{b}| \sin \theta$$

$$\Rightarrow \sin \theta = \frac{4}{5} \Rightarrow \cos \theta = \frac{3}{5}$$

$$\therefore |\vec{a} \cdot \vec{b}| = |\vec{a}| |\vec{b}| \cos \theta = 6$$

**Question:** If  $\frac{\pi}{4} \leq x \leq \frac{\pi}{4}$   $\begin{vmatrix} \sin x & \cos x & \cos x \\ \cos x & \sin x & \cos x \\ \cos x & \cos x & \sin x \end{vmatrix} = 0$ , number of solutions = ?

**Answer:** 1.00

**Solution:**

$$\begin{vmatrix} \sin x & \cos x & \cos x \\ \cos x & \sin x & \cos x \\ \cos x & \cos x & \sin x \end{vmatrix} = 0$$

$$R_1 \rightarrow R_1 + R_2 + R_3$$

$$(\sin x + 2 \cos x) \begin{vmatrix} 1 & 1 & 1 \\ \cos x & \sin x & \cos x \\ \cos x & \cos x & \sin x \end{vmatrix} = 0$$

$$C_2 \rightarrow C_2 - C_1; C_3 \rightarrow C_3 - C_1$$

$$(\sin x + 2 \cos x) \begin{vmatrix} 1 & 0 & 0 \\ \cos x & \sin x - \cos x & 0 \\ \cos x & 0 & \sin x - \cos x \end{vmatrix} = 0$$

$$\Rightarrow (\sin x + 2 \cos x)(\sin x - \cos x) = 0$$

$$\Rightarrow \tan x = 1 \Rightarrow 1 \text{ solution}$$

$$\Rightarrow \tan x = -2 \Rightarrow 0 \text{ solution}$$

Total 1 solution

**Question:**  $\cot\left(\frac{\pi}{24}\right) = ?$

**Answer:**

**Solution:**

$$\cot\left(\frac{\pi}{24}\right) = \cot(7.5) = \cot\left(\frac{15}{2}\right)$$

$$1 + \cos(15) = 1 + \cos(45 - 30) = 1 + \left(\frac{1}{\sqrt{2}}\right)\left(\frac{\sqrt{3}}{2}\right) + \left(\frac{1}{\sqrt{2}}\right)\left(\frac{1}{2}\right) = \frac{\sqrt{3} + 1 + 2\sqrt{2}}{2\sqrt{2}}$$

$$\sin^2 15 = \sin^2(45 - 30) = \left(\frac{\sqrt{3} - 1}{2\sqrt{2}}\right)^2 = \frac{4 - 2\sqrt{3}}{8} = \frac{2 - \sqrt{3}}{4}$$

$$\cot^2\left(\frac{15}{2}\right) = \frac{1 + \cos 15}{1 - \cos 15} = \frac{(1 + \cos 15)^2}{\sin^2 15} = \frac{(2\sqrt{2} + \sqrt{3} + 1)^2}{8\left(\frac{2 - \sqrt{3}}{4}\right)} = \frac{(2\sqrt{2} + \sqrt{3} + 1)^2}{4 - 2\sqrt{3}}$$

$$\cot\left(\frac{15}{2}\right) = \frac{(2\sqrt{2} + \sqrt{3} + 1)}{\sqrt{4 - 2\sqrt{3}}} = \frac{(2\sqrt{2} + \sqrt{3} + 1)}{\sqrt{3} - 1} = \frac{(2\sqrt{2} + \sqrt{3} + 1)(\sqrt{3} + 1)}{2} = \sqrt{6} + \sqrt{2} + \sqrt{3} + \sqrt{4}$$

**Question:** Equation of circle  $\operatorname{Re}(z^2) + 2(\operatorname{img}(z))^2 + 2\operatorname{Re}(z) = 0$  where  $z = x + iy$ . A line passes through the vertex of parabola  $x^2 - 6x + y + 13 = 0$  and center of circle, then the y intercept of the line is \_\_\_?

**Answer:** -1.00

**Solution:**

$$\text{Equation of circle is } x^2 - y^2 + 2y^2 + 2x = 0$$

$$\Rightarrow x^2 + y^2 + 2x = 0$$

$$\Rightarrow \text{centre } (-1, 0)$$

$$\text{Also, } (x - 3)^2 = -y - 13 + 9 = -(y + 4) \Rightarrow \text{vertex } (3, -4)$$

$\therefore$  Equation of line passing through  $(-1, 0)$  &  $(3, -4)$  is

$$y = \frac{-4}{4}(x+1) \Rightarrow x + y = -1$$

$\therefore$  y-intercept of line = -1

**Question:** If  $f(x) = \frac{P(x)}{\sin(x-2)}$ , at  $x=2, p(x)=7$ .  $P(x)$  is a polynomial where  $P(3)=9$ .

Find  $P(5)$ .

**Answer:** 39.00

**Solution:**

$$f(x) = \frac{P(x)}{\sin(x-2)}$$

$$P''(x) = c \Rightarrow P(x) = ax^2 + bx + c$$

$$P(2) = 0 \Rightarrow 4a + 2b + c = 0$$

$$P'(2) = 7 \Rightarrow 4a + b = 7$$

$$P(3) = 9 \Rightarrow 9a + 3b + c = 9$$

$$a = 2, b = -1, c = -6$$

$$\therefore P(x) = 2x^2 - x - 6$$

$$\Rightarrow P(5) = 39$$

**Question:**  $\left(2 + \frac{3}{x}\right)^n$  if coefficient of  $x^7$  &  $x^8$  is same

**Answer:** 55.00

**Solution:**

$${}^n C_7 (2)^{n-7} \left(\frac{1}{3}\right)^7 = {}^n C_8 (2)^{n-8} \left(\frac{1}{3}\right)^8$$

$$\frac{{}^n C_8}{{}^n C_7} = 3 \cdot 2 = 6 = \frac{n-7}{8} \Rightarrow n = 55$$

**Question:** Find the value of  $\sum_{n=8}^{100} \left[ \frac{(-1)^n n}{2} \right]$  where  $[x]$  greatest integer function n.

**Answer:** 4.00

**Solution:**

$$S = 4 - 5 + 5 - 6 + 6 \dots - 50 + 50 = 4$$

**Question:** If  $a\hat{i} + a\hat{j} + c\hat{k}, \hat{i} + \hat{k}$  and  $c\hat{i} + c\hat{j} + b\hat{k}$  are coplanar then  $c = ?$

**Answer:** ()

**Solution:**



$$\begin{vmatrix} a & a & c \\ 1 & 0 & 1 \\ c & c & b \end{vmatrix} = 0$$

$$\Rightarrow -ac - a(b-c) + c^2 = 0$$

$$c^2 = ab$$

$$x = \sqrt{ab}$$

**Question:** Find the number of irrational terms in  $\left(2^{\frac{1}{3}} + 3^{\frac{1}{4}}\right)^{12}$ .

**Answer:** 11.00

**Solution:**

$$T_{r+1} = {}^{12}C_r \cdot (2)^{\frac{r}{3}} \cdot (3)^{\frac{12-r}{4}} = {}^{12}C_r \cdot (3)^3 \cdot (2)^{\frac{r}{3}} \cdot (3)^{\frac{-r}{4}}$$

$\therefore$  Number of rational terms = 2 ( $r = 0, 1, 2$ )

$\therefore$  Number of irrational term =  $13 - 2 = 11$

Thank You  
for downloading the PDF

FREE LIVE ONLINE

# MASTER CLASSES

FREE Webinars by Expert Teachers



Vedantu

## FREE MASTER CLASS SERIES

- ✔ For **Grades 6-12th** targeting **JEE, CBSE, ICSE** & much more
- ✔ **Free 60 Minutes Live Interactive** classes everyday
- ✔ Learn from the **Master Teachers** - India's best

Register for **FREE**

Limited Seats!