

CCE PR
UNREVISED REDUCED SYLLABUS
NSR & NSPR

D

ಕರ್ನಾಟಕ ಶಾಲಾ ಪರೀಕ್ಷೆ ಮತ್ತು ಮೌಲ್ಯನಿರ್ಣಯ ಮಂಡಲಿ, ಮಲ್ಲೇಶ್ವರಂ, ಬೆಂಗಳೂರು - 560 003
KARNATAKA SCHOOL EXAMINATION AND ASSESSMENT BOARD,
MALLESHWARAM, BENGALURU - 560 003

ಎಸ್.ಎಸ್.ಎಲ್.ಸಿ. ಪರೀಕ್ಷೆ, ಮಾರ್ಚ್ / ಏಪ್ರಿಲ್ — 2023
S. S. L. C. EXAMINATION, MARCH/APRIL, 2023

ಮಾದರಿ ಉತ್ತರಗಳು
MODEL ANSWERS

ದಿನಾಂಕ : 10. 04. 2023]

ಸಂಕೇತ ಸಂಖ್ಯೆ : **83-E (Phy)**

Date : 10. 04. 2023]

CODE NO. : **83-E (Phy)**

ವಿಷಯ : ವಿಜ್ಞಾನ
Subject : SCIENCE

(ಭೌತ ವಿಜ್ಞಾನ, ರಸಾಯನ ವಿಜ್ಞಾನ ಮತ್ತು ಜೀವ ವಿಜ್ಞಾನ / **Physics, Chemistry & Biology**)

(ಪುನರಾವರ್ತಿತ ಖಾಸಗಿ ಅಭ್ಯರ್ಥಿ / ಎನ್.ಎಸ್.ಆರ್. & ಎನ್.ಎಸ್.ಪಿ.ಆರ್.)

(Private Repeater / NSR & NSPR)

(ಭೌತಶಾಸ್ತ್ರ / Physics)

(ಇಂಗ್ಲಿಷ್ ಮಾಧ್ಯಮ / English Medium)

[ಗರಿಷ್ಠ ಅಂಕಗಳು : 100

[Max. Marks : 100



PART - A
(Physics)

Qn. Nos.	Value Points	Total
I.	Multiple choice questions :	4 × 1 = 4
1.	The device used to measure the rate of current in a circuit is (A) Ammeter (B) Voltmeter (C) Galvanometer (D) Battery Ans. : (A) Ammeter	1

CCE PR/NSR & NSPR(D)/900/7825 (MA)-PHY

[Turn over

Qn. Nos.	Value Points	Total
2.	<p>The focal Length of a lens is + 0.50 m. The power of the lens and type is</p> <p>(A) + 2.0 D and concave lens</p> <p>(B) + 2.0 D and convex lens</p> <p>(C) - 2.0 D and concave lens</p> <p>(D) - 2.0 D and convex lens</p> <p><i>Ans. :</i></p> <p>(B) + 2.0 D and convex lens</p>	1
3.	<p>A light ray enters to rarer medium from a denser medium. Then the speed of that light ray</p> <p>(A) decreases and bends towards the normal</p> <p>(B) increases and bends away from the normal</p> <p>(C) decreases and bends away from the normal</p> <p>(D) increases and bends towards the normal</p> <p><i>Ans. :</i></p> <p>(B) increases and bends away from the normal</p>	1
4.	<p>The inner wall of the solar cooker is painted black. Because black colour</p> <p>(A) reflects light</p> <p>(B) converges solar rays</p> <p>(C) prevents from rusting</p> <p>(D) absorbs more heat</p> <p><i>Ans. :</i></p> <p>(D) absorbs more heat</p>	1

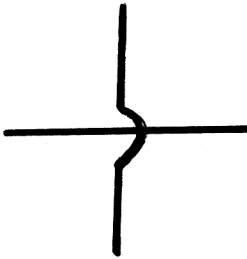
Qn. Nos.	Value Points	Total
II.	Answer the following questions : 2 × 1 = 2	
5.	<p>Write the symbols of the following components used in an electric circuit.</p> <p>i) Rheostat</p> <p>ii) Wires crossing without joining</p> <p>Ans. :</p> <div style="display: flex; align-items: center; justify-content: center;"> <div style="text-align: center;">  <p>i)</p> </div> <div style="margin: 0 20px;">OR</div> <div style="text-align: center;">  </div> </div> <p style="text-align: center;">Rheostat</p> <div style="text-align: center;">  <p>ii)</p> </div> <p style="text-align: center;">Wires crossing without joining $\frac{1}{2} + \frac{1}{2}$</p>	1
6.	<p>What does the thumb indicate in the right hand thumb rule ?</p> <p>Ans. :</p> <p>Direction of current</p>	1
III.	<p>Answer the following questions : 5 × 2 = 10</p> <p>7. Light enters from air to benzene having refractive index 1.50. Calculate the speed of light in benzene. (Speed of light in air : $3 \times 10^8 \text{ ms}^{-1}$)</p> <p style="text-align: center;">OR</p> <p>A concave lens has focal length of 12 cm. At what distance should the object from the lens be placed so that it forms an image at 9 cm from the lens ?</p> <p>Ans. :</p> <p>Refractive index of a medium =</p> $\frac{\text{Speed of light in air}}{\text{Speed of light in Benzene}}$ <p style="text-align: center;">OR</p>	

Qn. Nos.	Value Points	Total
	$n_m = \frac{C}{V}$	$\frac{1}{2}$
	$1.50 = \frac{3 \times 10^8}{\text{Speed of light in Benzene}}$	$\frac{1}{2}$
	$1.50 \times \text{Speed of light in Benzene} = 3 \times 10^8$	$\frac{1}{2}$
	$\text{Speed of light in Benzene} = \frac{3 \times 10^8}{1.50}$	$\frac{1}{2}$
	$\text{Speed of light in Benzene} = 2 \times 10^8 \text{ ms}^{-1}$	2
	OR	
	$f = -12 \text{ cm}$	$\frac{1}{v} - \frac{1}{u} = \frac{1}{f}$
	$v = -9 \text{ cm}$	$\frac{1}{u} = \frac{1}{v} - \frac{1}{f}$
	$u = ?$	$\frac{1}{u} = \frac{1}{-9} - \frac{1}{-12}$
		$\frac{1}{u} = -\frac{1}{9} + \frac{1}{12}$
		$\frac{1}{u} = \frac{-4+3}{36}$
		$\frac{1}{u} = \frac{-1}{36}$
		$-u = 36$
		$u = -36 \text{ cm}$
		$\frac{1}{2}$
		2
8.	Name the major constituent of biogas and write the properties of biogas.	
	OR	
	List the hazards of nuclear power generation.	

Qn. Nos.	Value Points	Total
	<p><i>Ans. :</i></p> <ul style="list-style-type: none"> ★ Methane / CH₄ 1/2 ★ When burnt leaves no residue like ash 1/2 ★ It burns without smoke 1/2 ★ Its heating capacity is high 1/2 <p style="text-align: center;">OR</p> <ul style="list-style-type: none"> ★ Improper nuclear-waste storage and disposal result in environmental contamination 1 ★ There is a risk of accidental leakage of nuclear radiation 1 <p style="text-align: center;">(Consider any suitable answer)</p>	2
9.	<p>“Connecting electrical appliances in parallel is advantageous over connecting them in series” in a circuit. Justify.</p> <p><i>Ans. :</i></p> <ul style="list-style-type: none"> ★ This is helpful particularly when each gadget has different resistance and requires different current to operate properly. ★ In the parallel circuit when one component fails the circuit will not break. ★ Parallel circuit divides the current through the electrical gadgets. <p style="text-align: right;">(Any two) 1 + 1</p>	2
10.	<p>Draw the diagram of a simple electric motor and label ‘brushes’.</p> <p><i>Ans. :</i></p>	

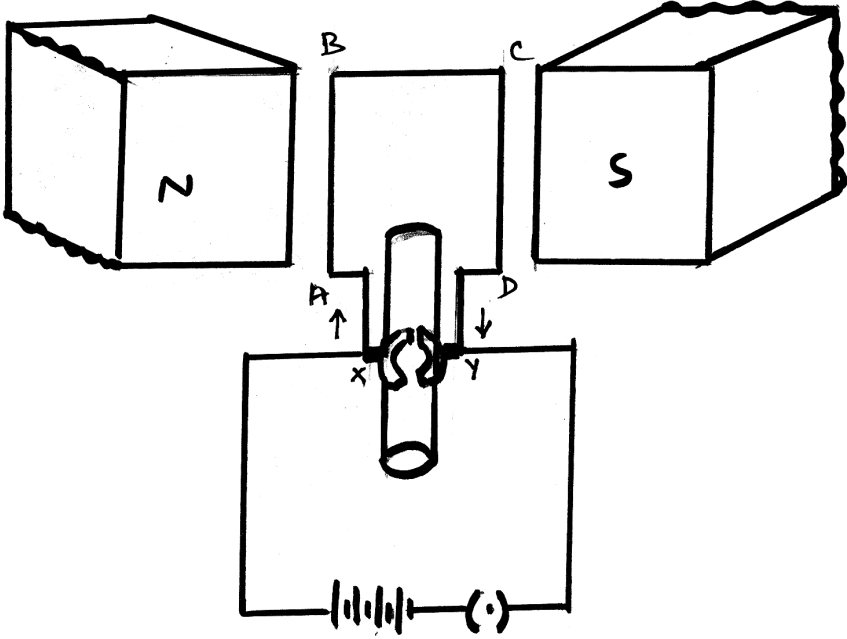
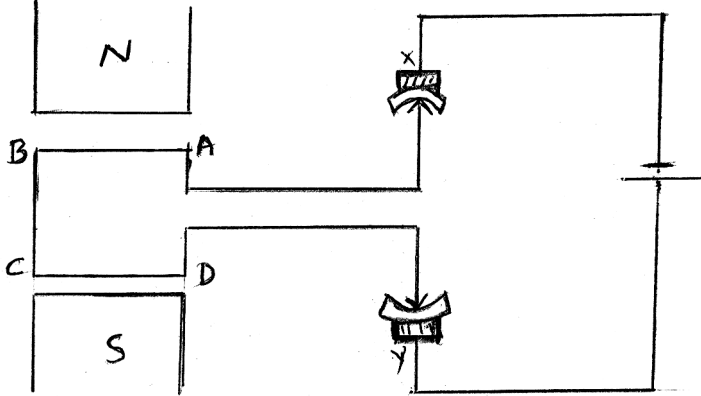
Qn. Nos.	Value Points	Total
	 <p data-bbox="635 1025 943 1066">X, Y-Carbon brushes</p> <p data-bbox="916 1084 1225 1124">For diagram — $1\frac{1}{2}$</p> <p data-bbox="916 1151 1225 1191">For label — $\frac{1}{2}$</p> <p data-bbox="1283 1173 1310 1214">2</p> <p data-bbox="767 1240 820 1281">OR</p>  <p data-bbox="687 1756 900 1796">Electric motor</p> <p data-bbox="916 1809 1225 1850">For diagram — $1\frac{1}{2}$</p> <p data-bbox="916 1877 1225 1917">For label — $\frac{1}{2}$</p> <p data-bbox="1283 1899 1310 1939">2</p>	

Qn. Nos.	Value Points	Total
11.	<p>When an object is placed between F_1 and $2F_1$ of a concave lens, mention the position, size and nature of the image formed. (F_1 : Principal focus of the lens)</p> <p>Ans. :</p> <ul style="list-style-type: none"> ★ Beyond $2F_1$ ★ Enlarged ★ Real and inverted 	2
<p>IV. Answer the following questions : 3 × 3 = 9</p>		
12.	<p>State Ohm's law. On which factors does the resistance of a conductor depend ? Mention the SI unit of electric power.</p> <p style="text-align: center;">OR</p> <p>State Joule's law of heating. How is fuse connected in the circuits ? Name the metal used in the filament and the gas filled in electric bulb.</p> <p>Ans. :</p> <p>At constant temperature, the potential difference, V, across the ends of a given metallic wire in an electric circuit is directly proportional to the current flowing through it. 1</p> <p style="text-align: center;">OR</p> <p style="text-align: center;">$V \propto I$</p> <p style="text-align: center;">$V = IR$</p> <p>The factors on which resistance of a conductor depends</p> <ul style="list-style-type: none"> i) The length of the conductor $\frac{1}{2}$ ii) Area of cross-section of the conductor $\frac{1}{2}$ iii) The nature of the material $\frac{1}{2}$ iv) The temperature. (any three) <ul style="list-style-type: none"> ★ watt – W $\frac{1}{2}$ 	3
<p>OR</p>		

Qn. Nos.	Value Points	Total
	<p>Heat produced in a resistor is</p> <p>i) directly proportional to the square of current for a given resistance, $\frac{1}{2}$</p> <p>ii) directly proportional to resistance for a given current, and $\frac{1}{2}$</p> <p>iii) directly proportional to the time for which the current flows through the resistor $\frac{1}{2}$</p> <p><i>Note :</i> If the student writes directly $H = I^2Rt$ — 1 mark</p> <p>★ Tungsten $\frac{1}{2}$</p> <p>★ Nitrogen / N₂ OR Argon / Ar 1</p> <p>(Consider if He / Ne / Kr written)</p>	3
13.	<p>The resistors R_1, R_2 and R_3 have the values 10 Ω, 20 Ω and 60 Ω respectively, which have been parallelly connected to a battery of 24 V in an electric circuit. Then calculate the following :</p> <p>i) The current flowing through each resistor</p> <p>ii) The total current in the circuit</p> <p>iii) The total resistance of the circuit.</p> <p><i>Ans. :</i></p> <p>i) $I_1 = \frac{V}{R_1} = \frac{24 \text{ V}}{10 \Omega} = 2.4 \text{ A}$ $\frac{1}{2}$</p> <p>$I_2 = \frac{V}{R_2} = \frac{24 \text{ V}}{20 \Omega} = 1.2 \text{ A}$ $\frac{1}{2}$</p> <p>$I_3 = \frac{V}{R_3} = \frac{24 \text{ V}}{60 \Omega} = 0.4 \text{ A}$ $\frac{1}{2}$</p>	

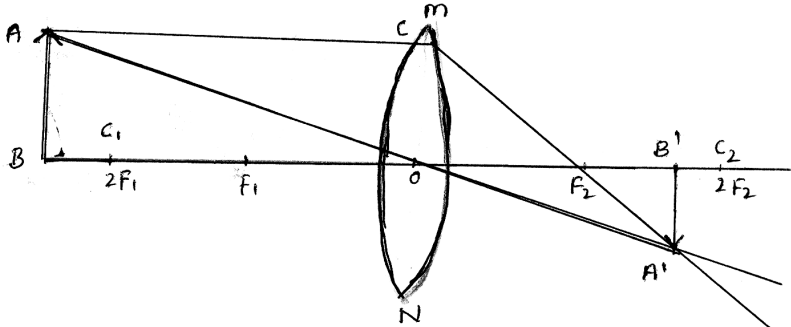
Qn. Nos.	Value Points	Total
	ii) $I = I_1 + I_2 + I_3$ $= (2.4 + 1.2 + 0.4) \text{ A}$ $= 4 \text{ A}$	$\frac{1}{2}$
	iii) $\frac{1}{R_p} = \frac{1}{10} + \frac{1}{20} + \frac{1}{60} = \frac{1}{6}$	$\frac{1}{2}$
	$\frac{1}{R_p} = \frac{1}{6}$	$\frac{1}{2}$
	$R_p = 6 \Omega.$	$\frac{1}{2}$
14.	<p>Draw the ray diagram for the image formation in a convex lens when the object is placed beyond $2F_1$. Mention the position and nature of the image formed.</p> <p>[F_1 : Principal focus of the lens]</p> <p>Ans. :</p>  <p style="text-align: right;">For ray diagram — $\frac{2}{2}$</p> <ul style="list-style-type: none"> ★ Position of the image : Between F_2 & $2F_2$. $\frac{1}{2}$ ★ Nature of the image : Real and inverted. $\frac{1}{2}$ 	3
V.	Answer the following question :	1 × 4 = 4
15.	a) What is solenoid ? Write the properties of the magnetic field lines formed around a current carrying solenoid. b) What is alternating current ? Electric appliances having metallic body are connected to earth wire, why ?	

Qn. Nos.	Value Points	Total
	<p><i>Ans. :</i></p> <p>a) ★ A coil of many circular turns of insulated copper wire wrapped closely in the shape of a cylinder is called a solenoid. 1</p> <p>★ At the ends/poles of a solenoid, the magnetic field lines appear in the form of concentric circles. $\frac{1}{2}$</p> <p>★ At the centre / inside the solenoid the magnetic field lines appear in the form of parallel straight lines. $\frac{1}{2}$</p> <p>b) ★ The current that changes direction after equal intervals of time is called an alternating current. 1</p> <p>★ The metallic body is connected to the earth wire provides a low resistance conducting path for the current. $\frac{1}{2}$</p> <p>★ Thus, it ensures that any leakage of current to the metallic body of the appliance keeps its potential to that of the earth and the user may not get a severe electric shock. $\frac{1}{2}$</p>	4
VI.	Answer the following question :	1 × 5 = 5
16.	<p>a) Define focal length, principal axis and aperture of the spherical lens.</p> <p>b) State two laws of refraction of light.</p>	
	<p><i>Ans. :</i></p> <p>a) ★ The distance of the principal focus from the optical centre of a lens is called its focal length. 1</p> <p>★ An imaginary straight line passing through the two centres of curvature of a lens is called its principal axis. 1</p> <p>★ The effective diameter of the circular outline of a spherical lens is called its aperture. 1</p>	

Qn. Nos.	Value Points	Total
	b) <ul style="list-style-type: none"><li data-bbox="427 344 1235 495">★ The incident ray, the refracted ray and the normal to the interface of two transparent media at the point of incidence, all lie in the same plane. 1<li data-bbox="427 533 1235 685">★ The ratio of sine of angle of incidence to the sine of angle of refraction is a constant, for the light of a given colour and for the given pair of media. 1	5

=====

**CCE PR
UNREVISED REDUCED SYLLABUS
NSR & NSPR**

D

ಕರ್ನಾಟಕ ಶಾಲಾ ಪರೀಕ್ಷೆ ಮತ್ತು ಮೌಲ್ಯನಿರ್ಣಯ ಮಂಡಲಿ, ಮಲ್ಲೇಶ್ವರಂ, ಬೆಂಗಳೂರು - 560 003
**KARNATAKA SCHOOL EXAMINATION AND ASSESSMENT BOARD,
MALLESHWARAM, BENGALURU - 560 003**

ಎಸ್.ಎಸ್.ಎಲ್.ಸಿ. ಪರೀಕ್ಷೆ, ಮಾರ್ಚ್ / ಏಪ್ರಿಲ್ — 2023
S. S. L. C. EXAMINATION, MARCH/APRIL, 2023

ಮಾದರಿ ಉತ್ತರಗಳು

MODEL ANSWERS

ದಿನಾಂಕ : 10. 04. 2023]

ಸಂಕೇತ ಸಂಖ್ಯೆ : **83-E (Chem.)**

Date : 10. 04. 2023]

CODE NO. : **83-E (Chem.)**

ವಿಷಯ : ವಿಜ್ಞಾನ

Subject : SCIENCE

(ಭೌತ ವಿಜ್ಞಾನ, ರಸಾಯನ ವಿಜ್ಞಾನ ಮತ್ತು ಜೀವ ವಿಜ್ಞಾನ / **Physics, Chemistry & Biology**)

(ಪುನರಾವರ್ತಿತ ಖಾಸಗಿ ಅಭ್ಯರ್ಥಿ / ಎನ್.ಎಸ್.ಆರ್. & ಎನ್.ಎಸ್.ಪಿ.ಆರ್.)

(Private Repeater / NSR & NSPR)

(ರಸಾಯನಶಾಸ್ತ್ರ / **Chemistry**)

(ಇಂಗ್ಲಿಷ್ ಮಾಧ್ಯಮ / **English Medium**)

[ಗರಿಷ್ಠ ಅಂಕಗಳು : 100

[**Max. Marks : 100**

**PART - B
(Chemistry)**

Qn. Nos.	Value Points	Total
VII.	Multiple choice questions :	2 × 1 = 2
17.	A non-metallic oxide reacts with base and produces salt and water. Then the property of this non-metallic oxide is (A) acidic (B) basic (C) neutral (D) amphoteric Ans. : (A) acidic	1

CCE PR/NSR & NSPR(D)/900/7825 (MA)-CHE

[Turn over

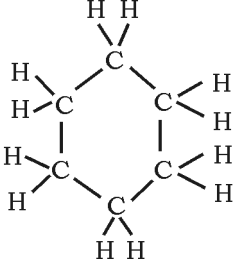
Qn. Nos.	Value Points	Total
18.	<p>Among ${}_2X^4$, ${}_8Y^{16}$, ${}_{10}Z^{20}$; the elements having zero valency are</p> <p>[2, 8, 10 are atomic numbers of elements]</p> <p>(A) ${}_2X^4$ and ${}_8Y^{16}$ (B) ${}_8Y^{16}$ and ${}_{10}Z^{20}$</p> <p>(C) ${}_2X^4$ and ${}_{10}Z^{20}$ (D) ${}_2X^4$, ${}_8Y^{16}$ and ${}_{10}Z^{20}$</p> <p>Ans. :</p> <p>(C) ${}_2X^4$ and ${}_{10}Z^{20}$</p>	1
VIII. Answer the following questions : 4 × 1 = 4		
19.	<p>The general formula of cycloalkanes is C_nH_{2n} and its first member is cyclopropane (C_3H_6). Write the molecular formula and structural arrangement of the fourth member of this homologous series.</p> <p>Ans. :</p> <p>Molecular formula : C_6H_{12}</p> <p style="text-align: center;">Structural arrangement</p>  <p style="text-align: right;">$\frac{1}{2}$</p>	$\frac{1}{2}$
20.	<p>State Mendeleev's periodic law.</p> <p>Ans. :</p> <p>The properties of elements are the periodic functions of their atomic masses.</p>	1
21.	<p>Potassium is kept immersed in kerosene. Why ?</p> <p>Ans. :</p> <p>Potassium reacts so vigorously that it catches fire.</p>	1
22.	<p>How many electrons are shared to form hydrogen molecule ?</p> <p>Ans. :</p> <p>One pair / Two electrons</p>	1

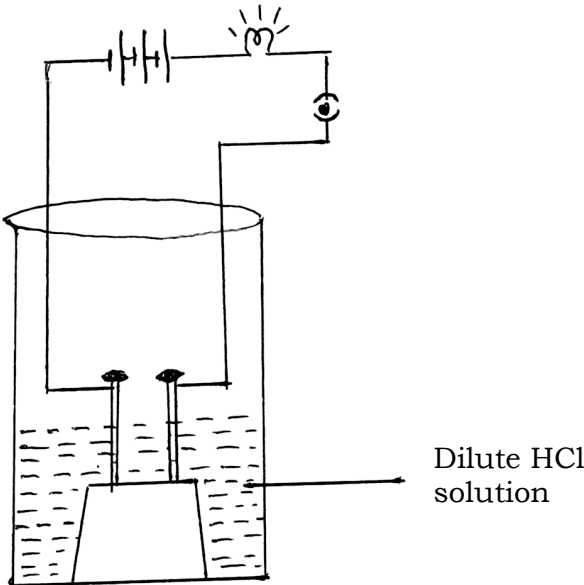
Qn. Nos.	Value Points	Total
IX.	Answer the following questions :	6 × 2 = 12
23.	<p>Draw the diagram of arrangement of apparatus to show that acid solution in water conducts electricity and label dilute HCl solution.</p> <p>Ans. :</p>  <p style="text-align: right;">Drawing : $1\frac{1}{2}$ Labelling : $\frac{1}{2}$</p>	2
24.	<p>Write the structural arrangement of isomers of butane.</p> <p>Ans. :</p> <pre> H H H H H — C — C — C — C — H H H H H C₄H₁₀ n-butane </pre> <pre> H H H C — H / \ H — C — C — C — H \ / H H C — H H C₄H₁₀ iso-butane </pre>	1 1 2

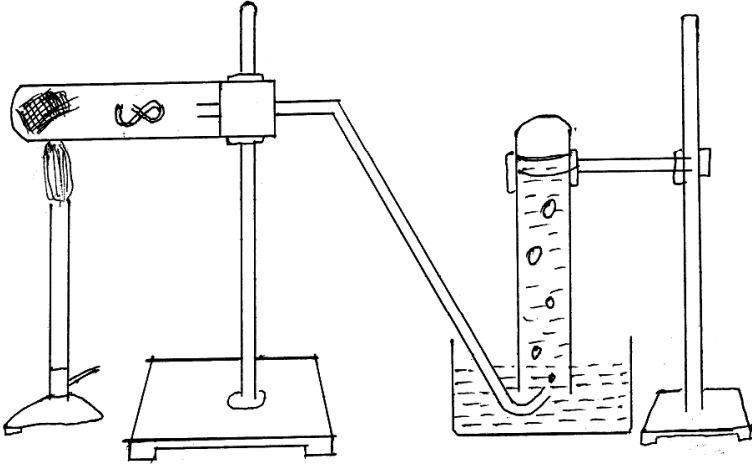
Qn. Nos.	Value Points	Total
25.	Draw the diagram of arrangement of apparatus to show the action of steam on a metal. <i>Ans. :</i> 	2
26.	What is malleability of metals ? Name a highly ductile metal and a liquid metal. <i>Ans. :</i> <ul style="list-style-type: none"> ★ Metals can be beaten into thin sheets 1 ★ Highly ductile metal — Gold $\frac{1}{2}$ ★ Liquid metal — Mercury $\frac{1}{2}$ 	2
27.	Carbon forms covalent compounds. Why ? Why do covalent compounds have low melting and boiling points ? <i>Ans. :</i> <ul style="list-style-type: none"> ★ Carbon shares its valence electrons with other atoms of carbon or with atoms of other elements. 1 ★ The force of attraction between the molecules are not very strong. 1 	2
28.	Explain the reason for applying baking soda on honeybee stung area. <i>Ans. :</i> <ul style="list-style-type: none"> ★ Honeybee sting has methanoic acid. 1 ★ Baking soda (sodium hydrogen carbonate) is a mild base, it neutralises the acid and gives relief. 1 	2

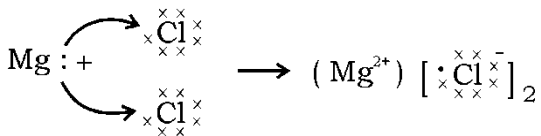
Qn. Nos.	Value Points	Total										
<p>X.</p> <p>29.</p>	<p>Answer the following questions : 3 × 3 = 9</p> <p>a) Depict the formation of magnesium chloride with the help of electron dot structure.</p> <p>b) Hydrogen gas is not liberated when a metal like zinc reacts with nitric acid. Why ?</p> <p style="text-align: center;">OR</p> <p>a) Why is aluminium oxide called an amphoteric oxide ?</p> <p>b) Write the differences between the physical properties of metals and non-metals.</p> <p><i>Ans. :</i></p> <p>a) $Mg \rightarrow Mg^{2+} + 2e^{-}$ $Cl + e^{-} \rightarrow Cl^{-}$</p> <p style="text-align: center;">  </p> <p>b) ★ Nitric acid is a strong oxidising agent $\frac{1}{2}$</p> <p>★ It oxidises the hydrogen produced to water and itself gets reduced to oxides of nitrogen. $\frac{1}{2}$</p> <p style="text-align: center;">OR</p> <p>a) Aluminium oxide reacts with both acids as well as bases to produce salt and water / Aluminium oxide shows both acidic as well as basic behaviour. 1</p> <table border="1" data-bbox="360 1574 1230 1917"> <thead> <tr> <th data-bbox="360 1574 801 1632">b) <i>Metals</i></th> <th data-bbox="801 1574 1230 1632"><i>Non-metals</i></th> </tr> </thead> <tbody> <tr> <td data-bbox="360 1632 801 1691">★ Malleable</td> <td data-bbox="801 1632 1230 1691">★ Non-malleable</td> </tr> <tr> <td data-bbox="360 1691 801 1749">★ Ductile</td> <td data-bbox="801 1691 1230 1749">★ Non-ductile</td> </tr> <tr> <td data-bbox="360 1749 801 1861">★ Good conductors of heat and electricity</td> <td data-bbox="801 1749 1230 1861">★ Bad conductors of heat and electricity</td> </tr> <tr> <td data-bbox="360 1861 801 1917">★ Have high melting point</td> <td data-bbox="801 1861 1230 1917">★ Have low melting point</td> </tr> </tbody> </table> <p style="text-align: center;">(Any two differences) 1 + 1</p>	b) <i>Metals</i>	<i>Non-metals</i>	★ Malleable	★ Non-malleable	★ Ductile	★ Non-ductile	★ Good conductors of heat and electricity	★ Bad conductors of heat and electricity	★ Have high melting point	★ Have low melting point	<p>3</p> <p>3</p> <p>1</p> <p>3</p>
b) <i>Metals</i>	<i>Non-metals</i>											
★ Malleable	★ Non-malleable											
★ Ductile	★ Non-ductile											
★ Good conductors of heat and electricity	★ Bad conductors of heat and electricity											
★ Have high melting point	★ Have low melting point											

Qn. Nos.	Value Points	Total																									
30.	<p>a) Observe the given part of the modern periodic table and answer the following questions :</p> <table border="1"> <thead> <tr> <th>Groups →</th> <th>1</th> <th>2</th> <th>13</th> <th>17</th> </tr> </thead> <tbody> <tr> <th>Periods ↓</th> <td></td> <td></td> <td></td> <td></td> </tr> <tr> <td>2</td> <td>—</td> <td>Be</td> <td>—</td> <td>—</td> </tr> <tr> <td>3</td> <td>Na</td> <td>Mg</td> <td>Al</td> <td>Cl</td> </tr> <tr> <td>4</td> <td>—</td> <td>Ca</td> <td>—</td> <td>—</td> </tr> </tbody> </table> <p>i) Which element is more electropositive ? Why ? ii) Atoms of which element have minimum atomic radius ? Why ?</p> <p>b) Mention the period and group number of the element that has atomic number 19.</p> <p>Ans. :</p> <p>a) i) Na $\frac{1}{2}$ Sodium has +1 valency / It loses one valence electron easily / electro-positivity decreases across the period. $\frac{1}{2}$</p> <p>ii) Cl $\frac{1}{2}$ It is in the 3rd period and it has 3 orbits / shells. OR It has high effective nuclear charge on the valence shell and pulls the electrons closer to the nucleus / across the period the atomic radius decreases. $\frac{1}{2}$</p> <p>b) Period — 4 $\frac{1}{2}$ Group — 1 $\frac{1}{2}$</p>	Groups →	1	2	13	17	Periods ↓					2	—	Be	—	—	3	Na	Mg	Al	Cl	4	—	Ca	—	—	3
Groups →	1	2	13	17																							
Periods ↓																											
2	—	Be	—	—																							
3	Na	Mg	Al	Cl																							
4	—	Ca	—	—																							
31.	<p>Name the gases liberated in the following chemical reactions. Write balanced chemical equations for these reactions.</p> <p>a) Zinc reacts with dilute sulphuric acid b) Sodium hydrogen carbonate reacts with dilute hydrochloric acid.</p> <p style="text-align: center;">OR</p>																										

Qn. Nos.	Value Points	Total																
	<p>a) The pH values of four solutions are given in the below table. Classify these into acidic and basic solutions :</p> <table border="1" style="margin-left: auto; margin-right: auto;"> <thead> <tr> <th>Solution</th> <th>pH Value</th> </tr> </thead> <tbody> <tr> <td>e</td> <td>5</td> </tr> <tr> <td>f</td> <td>13</td> </tr> <tr> <td>g</td> <td>9</td> </tr> <tr> <td>h</td> <td>2</td> </tr> </tbody> </table> <p>b) Name the antacid used to neutralise excess of acid in the stomach.</p> <p>Ans. :</p> <p>a) ★ Hydrogen gas $\frac{1}{2}$</p> <p>★ $\text{Zn} + \text{H}_2\text{SO}_4 \longrightarrow \text{ZnSO}_4 + \text{H}_2 \uparrow$ 1</p> <p>b) ★ Carbon dioxide $\frac{1}{2}$</p> <p>★ $\text{NaHCO}_3 + \text{HCl} \longrightarrow \text{NaCl} + \text{H}_2\text{O} + \text{CO}_2$ 1</p> <p style="text-align: center;">OR</p> <p>a)</p> <table border="1" style="margin-left: auto; margin-right: auto;"> <thead> <tr> <th>Acidic solutions</th> <th>Basic solutions</th> </tr> </thead> <tbody> <tr> <td>e</td> <td>f</td> </tr> <tr> <td>h</td> <td>g</td> </tr> </tbody> </table> <p style="text-align: right;">$4 \times \frac{1}{2}$</p> <p>b) Milk of magnesia / Magnesium hydroxide / $\text{Mg}(\text{OH})_2$ 1</p>	Solution	pH Value	e	5	f	13	g	9	h	2	Acidic solutions	Basic solutions	e	f	h	g	3
Solution	pH Value																	
e	5																	
f	13																	
g	9																	
h	2																	
Acidic solutions	Basic solutions																	
e	f																	
h	g																	
XI.	Answer the following question : 1 × 4 = 4																	
32.	<p>a) What are functional groups ? Name the functional group present in propanal and write the structure of this compound.</p> <p>b) Write the molecular formula and electron dot structure of ethane.</p>																	

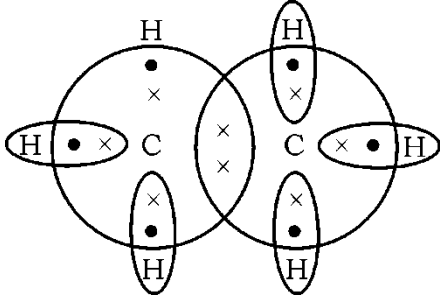
Qn. Nos.	Value Points	Total
	<p>Ans. :</p> <p>a) ★ An atom / atoms / heteroatoms responsible to bring specific properties in carbon compounds by replacing hydrogen atom / atoms. 1</p> <p>★ Aldehyde $\frac{1}{2}$</p> <p>★ $\begin{array}{c} \text{H} \quad \text{H} \quad \text{O} \\ \quad \quad \\ \text{H}-\text{C}-\text{C}-\text{C}-\text{H} \\ \quad \\ \text{H} \quad \text{H} \end{array}$ 1</p> <p>b) ★ C_2H_6 $\frac{1}{2}$</p> <p>★  1</p>	4

**CCE PR
UNREVISED REDUCED SYLLABUS
NSR & NSPR**

D

ಕರ್ನಾಟಕ ಶಾಲಾ ಪರೀಕ್ಷೆ ಮತ್ತು ಮೌಲ್ಯನಿರ್ಣಯ ಮಂಡಲಿ, ಮಲ್ಲೇಶ್ವರಂ, ಬೆಂಗಳೂರು - 560 003
**KARNATAKA SCHOOL EXAMINATION AND ASSESSMENT BOARD,
MALLESHWARAM, BENGALURU - 560 003**

ಎಸ್.ಎಸ್.ಎಲ್.ಸಿ. ಪರೀಕ್ಷೆ, ಮಾರ್ಚ್ / ಏಪ್ರಿಲ್ — 2023
S. S. L. C. EXAMINATION, MARCH/APRIL, 2023

ಮಾದರಿ ಉತ್ತರಗಳು

MODEL ANSWERS

ದಿನಾಂಕ : 10. 04. 2023]

ಸಂಕೇತ ಸಂಖ್ಯೆ : **83-E (Bio)**

Date : 10. 04. 2023]

CODE NO. : **83-E (Bio)**

ವಿಷಯ : ವಿಜ್ಞಾನ

Subject : SCIENCE

(ಭೌತ ವಿಜ್ಞಾನ, ರಸಾಯನ ವಿಜ್ಞಾನ ಮತ್ತು ಜೀವ ವಿಜ್ಞಾನ / **Physics, Chemistry & Biology**)

(ಪುನರಾವರ್ತಿತ ಖಾಸಗಿ ಅಭ್ಯರ್ಥಿ / ಎನ್.ಎಸ್.ಆರ್. & ಎನ್.ಎಸ್.ಪಿ.ಆರ್.)

(Private Repeater / NSR & NSPR)

(ಜೀವಶಾಸ್ತ್ರ / **Biology**)

(ಇಂಗ್ಲಿಷ್ ಮಾಧ್ಯಮ / **English Medium**)

[ಗರಿಷ್ಠ ಅಂಕಗಳು : **100**

[**Max. Marks : 100**

PART - C

(**Biology**)

Qn. Nos.	Value Points	Total
XII.	Multiple choice questions :	2 × 1 = 2
33.	“A person immediately starts running soon after observing a snake.” The correct transmission path of reflex impulse in this situation is (A) Receptor → Sensory neuron → Brain → Relay neuron → Motor neuron → Effector	

CCE PR/NSR & NSPR(D)/900/7825 (MA)-BIO

[Turn over

Qn. Nos.	Value Points	Total
	(B) Receptor → Sensory neuron → Spinal cord → Relay neuron → Motor neuron → Effector (C) Effector → Spinal cord → Sensory neuron → Relay neuron → Motor neuron → Receptor (D) Effector → Motor neuron → Relay neuron → Brain → Sensory neuron → Receptor <i>Ans. :</i> (B) Receptor → Sensory neuron → Spinal cord → Relay neuron → Motor neuron → Effector	1
34.	In humans, the testes are located outside the lower abdomen in the scrotum because (A) to protect testes from mechanical shocks (B) to increase the production of sperms (C) to maintain the secretion of testosterone hormone (D) to maintain the temperature required for sperm production. <i>Ans. :</i> (D) to maintain the temperature required for sperm production.	1
XIII.	Answer the following questions :	2 × 1 = 2
35.	What is the role of abscisic acid in plants ? <i>Ans. :</i> Abscisic acid inhibits growth in plants.	1
36.	Name any two sexually transmitted diseases and that are caused by the bacteria. <i>Ans. :</i> ★ Gonorrhoea ★ Syphilis	$\frac{1}{2}$ $\frac{1}{2}$ 1

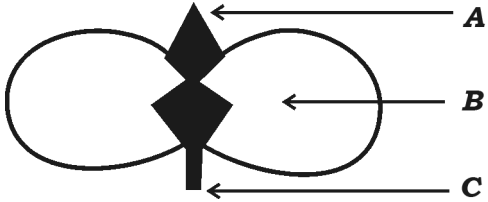
Qn. Nos.	Value Points	Total
XIV.	Answer the following questions : 7 × 2 = 14	
37.	<p>Mention the tools used for tracing the evolutionary relationships between the organisms.</p> <p><i>Ans. :</i></p> <ul style="list-style-type: none"> ★ Excavating $\frac{1}{2}$ ★ Time-dating $\frac{1}{2}$ ★ Studying fossils $\frac{1}{2}$ ★ Determining DNA sequences. $\frac{1}{2}$ 	2
38.	<p>Observe the given below figure :</p> <div style="text-align: center;">  <p style="text-align: center;">Germination of Seed</p> </div> <p>a) Which parts of the plant will develop from A and C ?</p> <p>b) What is the role of B in germination ?</p> <p><i>Ans. :</i></p> <p>a) A — Shoot / stem / future shoot / plumule $\frac{1}{2}$</p> <p style="padding-left: 40px;">C — Root / future root / Radicle. $\frac{1}{2}$</p> <p>b) B — Cotyledon (food store) provides nourishment to the plumule and radicle. 1</p>	2

Qn. Nos.	Value Points	Total										
39.	<p>List the differences between the biodegradable substances and non-biodegradable substances.</p> <p><i>Ans. :</i></p> <table border="1" data-bbox="363 611 1230 1543"> <thead> <tr> <th data-bbox="363 611 799 815"><i>Bio-degradable substances</i></th> <th data-bbox="799 611 1230 815"><i>Non-bio-degradable substances</i></th> </tr> </thead> <tbody> <tr> <td data-bbox="363 815 799 1019">★ Broken down by biological processes</td> <td data-bbox="799 815 1230 1019">★ Not broken down by biological processes</td> </tr> <tr> <td data-bbox="363 1019 799 1308">★ Do not persist in the environment for a long time</td> <td data-bbox="799 1019 1230 1308">★ Persist in the environment for a long time</td> </tr> <tr> <td data-bbox="363 1308 799 1424">★ Less harmful</td> <td data-bbox="799 1308 1230 1424">★ More harmful</td> </tr> <tr> <td data-bbox="363 1424 799 1543">★ Cause less pollution</td> <td data-bbox="799 1424 1230 1543">★ Cause more pollution</td> </tr> </tbody> </table> <p>(Any <i>two</i> differences)</p>	<i>Bio-degradable substances</i>	<i>Non-bio-degradable substances</i>	★ Broken down by biological processes	★ Not broken down by biological processes	★ Do not persist in the environment for a long time	★ Persist in the environment for a long time	★ Less harmful	★ More harmful	★ Cause less pollution	★ Cause more pollution	<p>1 + 1</p> <p>2</p>
<i>Bio-degradable substances</i>	<i>Non-bio-degradable substances</i>											
★ Broken down by biological processes	★ Not broken down by biological processes											
★ Do not persist in the environment for a long time	★ Persist in the environment for a long time											
★ Less harmful	★ More harmful											
★ Cause less pollution	★ Cause more pollution											
40.	<p>Draw the diagram to show the structure of nephron and label Bowman's capsule.</p> <p><i>Ans. :</i></p>											

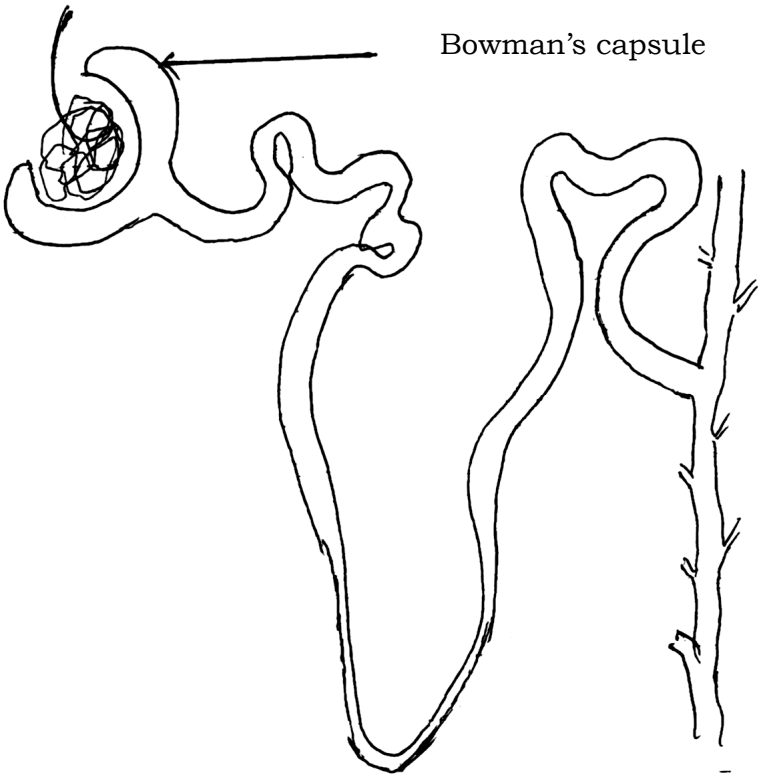
Qn. Nos.	Value Points	Total
	 <p data-bbox="842 353 1114 389">Bowman's capsule</p> <p data-bbox="927 1144 1225 1189">Diagram — $1\frac{1}{2}$</p> <p data-bbox="927 1211 1225 1256">Labelling — $\frac{1}{2}$</p>	2
41.	<p data-bbox="352 1323 1230 1424">How does the embryo get nourishment inside the mother's body ?</p> <p data-bbox="352 1458 440 1491"><i>Ans. :</i></p> <ul style="list-style-type: none"> <li data-bbox="363 1547 1230 1648">★ The embryo gets nutrition from the mother's blood with the help of a special tissue called placenta. 1 <li data-bbox="419 1704 919 1738">It is embedded in the uterine wall. <li data-bbox="363 1760 1230 1816">★ It supplies glucose and oxygen to the embryo $\frac{1}{2}$ <li data-bbox="363 1861 1230 1962">★ Brings wastes generated in the embryo to mother's blood. $\frac{1}{2}$ 	2

Qn. Nos.	Value Points	Total								
42.	Name the gland that secretes insulin hormone and mention the function of this hormone. Ans. : ★ Pancreas ★ Regulates blood sugar level	1 1 2								
43.	Write the differences between homologous organs and analogous organs. Ans. : <table border="1" style="width: 100%; border-collapse: collapse;"> <thead> <tr> <th style="text-align: center;"><i>Homologous organs</i></th> <th style="text-align: center;"><i>Analogous organs</i></th> </tr> </thead> <tbody> <tr> <td>★ Have similar structure / basic design</td> <td>★ Have different structures / basic design</td> </tr> <tr> <td>★ Perform different functions</td> <td>★ Perform same function</td> </tr> <tr> <td>★ Might be evolved from common ancestors</td> <td>★ Might not be evolved from common ancestors</td> </tr> </tbody> </table> (Any 2 differences)	<i>Homologous organs</i>	<i>Analogous organs</i>	★ Have similar structure / basic design	★ Have different structures / basic design	★ Perform different functions	★ Perform same function	★ Might be evolved from common ancestors	★ Might not be evolved from common ancestors	2 × 1 2
<i>Homologous organs</i>	<i>Analogous organs</i>									
★ Have similar structure / basic design	★ Have different structures / basic design									
★ Perform different functions	★ Perform same function									
★ Might be evolved from common ancestors	★ Might not be evolved from common ancestors									
XV.	Answer the following questions :	3 × 3 = 9								
44.	What is pollination ? What are the changes that occur in the flower after pollination ? Ans. : The transfer of pollen from the stamen to the stigma. ★ Germination of the pollen : Pollen tube develops. ★ Fertilization : Pollen grain enters the ovary through pollen tube and fuses with the ovum / egg. Zygote is formed. ★ Ovum develops into seed. Ovary grows rapidly and ripens into fruit. Petals, sepals, stamen, style and stigma may shrivel and fall off.	1 $\frac{1}{2}$ $\frac{1}{2}$ $\frac{1}{2}$ $\frac{1}{2}$ 3								

Qn. Nos.	Value Points	Total
45.	<p>How is ozone layer formed at higher levels of atmosphere and what is its function ?</p> <p><i>Ans. :</i></p> <p>★ Ozone at the higher levels of the atmosphere is a product of <i>UV</i> radiation acting on oxygen (O₂) molecule. The higher energy <i>UV</i> radiations split apart some molecular oxygen (O₂) into free oxygen (O) atoms.</p> <p style="text-align: center;">OR</p> $O_2 \xrightarrow{UV} O + O$ $O + O_2 \longrightarrow O_3$ <p style="text-align: center;">Ozone</p> <p>★ Ozone shields the surface of the earth from ultraviolet radiations (<i>UV</i>) from the sun.</p>	1 1 1
46.	<p>Tall pea plant producing red flowers (<i>TT RR</i>) is crossed with short pea plant producing white flowers (<i>tt rr</i>).</p> <p>i) Mention the type of plants produced from these plants in the <i>F</i>₁ generation.</p> <p>ii) Write the ratio of plants obtained in the <i>F</i>₂ generation by crossing the plants of <i>F</i>₁ generation and name the varieties of plants obtained.</p> <p style="text-align: center;">OR</p> <p>Analyse the situations given below. Answer the questions given :</p> <p><i>Situation 1 :</i> The number of green grasshoppers in a green zone has been increasing from one generation to another generation.</p>	3

Qn. Nos.	Value Points	Total
	<p><i>Situation 2</i> : The number of brown grasshoppers in the same green zone has been reducing.</p> <p>Here,</p> <p>a) Where could genetic drift be happened more ? Why ?</p> <p>b) How can natural selection be considered as an important factor in organic evolution ?</p> <p><i>Ans.</i> :</p> <p>i) Parents : $TT RR \times tt rr$</p> <p>Gametes : $TR \times tr$</p> <p>F_1 generation : $Tt Rr$ / OR</p> <p>Hybrid / mixed red flowers producing tall pea plants. $\frac{1}{2}$</p> <p>ii) Ratio = 9 : 3 : 3 : 1 $\frac{1}{2}$</p> <p>Types of plants</p> <p>a) 9-Tall — Red flowers producing pea plants $\frac{1}{2}$</p> <p>b) 3-Tall — White flowers producing pea plants $\frac{1}{2}$</p> <p>c) 3-Short — Red flowers producing pea plants $\frac{1}{2}$</p> <p>d) 1-Short — White flowers producing pea plant $\frac{1}{2}$</p> <p style="text-align: center;">OR</p> <p>a) In situation (1), $\frac{1}{2}$</p> <p>because, natural selection is positive. Among the organisms of new generation of green grasshoppers new combination in genetic material have been accumulating and genetic drift increases. 1</p> <p>b) In situation (2) $\frac{1}{2}$</p> <p>because, natural selection is not positive. Due to this, the number of brown grasshoppers is reduced and may disappear in future. So the natural selection is an important event. 1</p>	3
		3

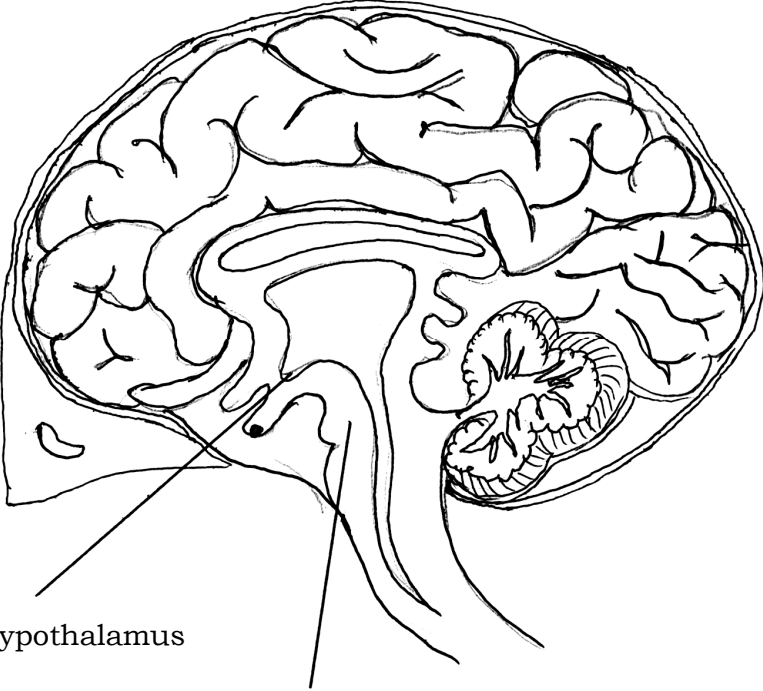
Qn. Nos.	Value Points	Total
XVI.	Answer the following questions : 2 × 4 = 8	
47.	<p>Draw the diagram showing the structure of human brain.</p> <p>Label the following parts :</p> <p>i) Hypothalamus</p> <p>ii) Pons.</p> <p><i>Ans. :</i></p> <div style="text-align: center;">  <p>Hypothalamus</p> <p>Pons</p> </div> <p style="text-align: right;">Drawing — 3 Labelling — $\frac{1}{2} + \frac{1}{2}$</p>	4
48.	<p>Write any four differences between aerobic and anaerobic respiration.</p> <p style="text-align: center;">OR</p> <p>Explain the role of xylem and phloem tissues in the transportation of materials in plants.</p> <p><i>Ans. :</i></p>	

Qn. Nos.	Value Points		Total
	<i>Aerobic respiration</i>	<i>Anaerobic respiration</i>	
	★ Occurs in the presence of oxygen	★ Occurs in the absence of oxygen	
	★ Carbon dioxide and water are produced	★ Ethanol and carbon dioxide are produced	
	★ Takes place in mitochondria	★ Takes place in yeast cells	
	★ More amount of energy is released	★ Lesser amount of energy is released	
	4 × 1		4
OR			
<i>Xylem</i> : Water conducting tissue.			
	★ In xylem tissue, vessels and tracheids of roots, stem and leaves are interconnected to form a continuous system of water-conducting channel reaching all parts of the plant.		1
	★ Transpiration (loss of water through stomata) creates suction pressure and creates a column of water.		$\frac{1}{2}$
	★ This steadily pushes the water upward with dissolved minerals in it.		$\frac{1}{2}$
<i>Phloem</i> : Food conducting tissue.			
	★ Phloem translocates soluble products of photosynthesis, amino acids and other substances from the leaves to storage organs of roots, fruits and seeds, and to the growing organs.		1

Qn. Nos.	Value Points	Total
	<ul style="list-style-type: none"><li data-bbox="363 338 1233 501">★ Translocation takes place in sieve tube with the help of companion cell, both in upward and downward directions. $\frac{1}{2}$ <li data-bbox="363 562 1233 725">★ Osmotic pressure helps water to move into the phloem tissue and moves other materials from the phloem to other tissues. $\frac{1}{2}$	4
