

JEE-Main-26-06-2022-Shift-1 (Memory Based)

Physics

Question: A wave of wavelength = 3λ strikes a particle of size $\frac{1}{100}$ th of λ then this

phenomenon is called as

Options:

- (a) Diffraction
- (b) Scattering
- (c) Reflection
- (d) Refraction

Answer: (a)

Solution:

For the given wavelength and obstacle size, diffraction will happen.

Question: A ball of mass 0.5 gm is released from height 10 m from rest. Find height where magnitude of acceleration and velocity is same

Options:

- (a) 7 m
- (b) 5 m
- (c) 3 m
- (d) 2 m

Answer: (b)

Solution:

We need $|\vec{a}| = |\vec{v}|$

$$\Rightarrow g = u + at = 0 + gt$$

$$\Rightarrow \boxed{t = 1 \text{ sec}}$$

Distance travelled in 1 sec

$$x = ut + \frac{1}{2}gt^2 = \frac{1}{2}(10)(1)^2$$

$$= 5m$$

\therefore Height from the ground

$$= 10 - 5 = 5m$$

Question: A ring (m, r) rotating at angular speed ω has two point masses (m_1) attached to its circumference. Their find angular speed is?

Options:

(a) $\frac{m\omega}{m - 2m_1}$

(b) $\frac{m\omega}{m + 1m_1}$

(c) $\frac{m\omega}{m - 2m}$

(d) $\frac{m\omega}{m + 2m_1}$

Answer: (d)

Solution:

$$I_1\omega_i = I_2\omega_2$$

$$mr^2\omega = (mx^2 + m_1r^2 \times 2)\omega_f$$

$$m\omega = (m + 2m_1)\omega_f$$

$$\omega_f = \frac{m\omega}{m + 2m_1}$$

Question: An ideal Gas having molecular mass m_0 is in a container moving with velocity v . If container is suddenly stopped, then find the rise in m temp of Gas. [$r = 1.4$]

Options:

(a) $\frac{m_0v^2}{5R}$

(b) $\frac{m_0v^2}{1R}$

(c) $\frac{m_0v^2}{3R}$

(d) $\frac{m_0v^2}{4R}$

Answer: (a)

Solution:

Since $r = 1.4$, it is a diatomic gas.

$$\text{K.E. of } n \text{ moles of gas} = \frac{1}{2} m n v^2$$

Loss in this K.E. = Gain in internal energy

$$= \frac{1}{2} m n v^2 = n c v \Delta T = n \left(\frac{5}{2} R \right) \Delta T$$

$$\Rightarrow \Delta T = \frac{m_0 v^2}{5R}$$

Question: An α particle and proton enter magnetic field with same speed. Find ratio of radius of α particle to proton.

Options:

(a) $\frac{3}{2}$

(b) $\frac{2}{1}$

(c) $\frac{1}{2}$

(d) $\frac{2}{4}$

Answer: (a)

Solution:

$$R = \frac{mv}{qB}$$

$$R_{\alpha} = \frac{m_{\alpha}v}{q_{\alpha}B}$$

$$\bar{R}_p = \frac{m_p v}{q_p B} = \frac{q_p m_{\alpha}}{m_p q_{\alpha}}$$

$$= \frac{e(4m)}{m(2e)}$$

$$= \frac{2}{1}$$

Question: A ball is thrown vertically upward. At the maximum height. Which of the following is zero?

Options:

(a) Momentum

(b) P.E

(c) Acceleration

(d) Force

Answer: (a)

Solution:

At max height, ball stops momentarily before changing its direction. Hence momentum i.e. mv is zero.

Question: The magnetic flux strength a surface is changing with time as $\phi = 5t^3 + 4t^2 + 2t$.

The resistance of coil is 5Ω . Find current at $t = 2$ sec.

Options:

(a) 14.3 A

(b) 13.2 A

(c) 15.6 A

(d) 16.1 A

Answer: (c)

Solution:

$$\phi = 5t^3 + 4t^2 + 2t$$

$$R = 5\Omega$$

$$|\mathcal{E}| = \frac{d\phi}{dt} = 15t^2 + 8t + 2$$

At $t = 2$ sec

$$|\mathcal{E}| = 15(2)^2 + 8(2) + 2$$

$$= 78$$

$$\therefore i = \frac{78}{5} = 15.6A$$

Question: Find current delivered by battery

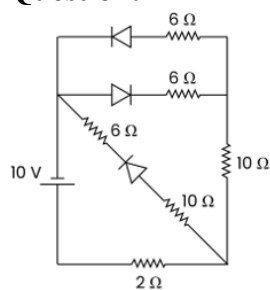

Options:

- (a) 1 Amp
- (b) 3 Amp
- (c) 5 Amp
- (d) 2 Amp

Answer: (a)

Solution:

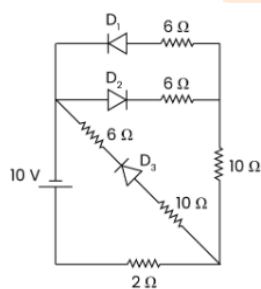

D_2 is reverse biased, therefore

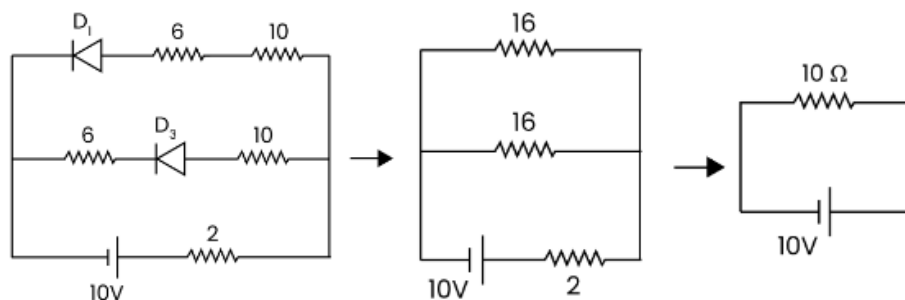

$$i = \frac{10}{10} = 1 \text{ Amp.}$$

Question: A simple pendulum of length L is oscillating in lift which is Accelerating upwards with Acceleration $g/6$

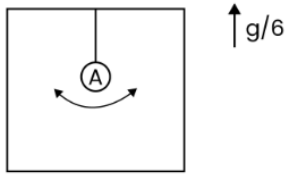

Find time period?

Options:

(a) $2\pi\sqrt{\frac{5l}{7g}}$

(b) $2\pi\sqrt{\frac{6l}{7g}}$

(c) $2\pi\sqrt{\frac{6l}{3g}}$

(d) $2\pi\sqrt{\frac{4l}{5g}}$

Answer: (b)

Solution:

$$2\pi\sqrt{\frac{6L}{7g}}$$

$$T = 2\pi\sqrt{\frac{l}{g_{eff}}} = 2\pi\sqrt{\frac{l}{g + g/6}}$$

$$= 2\pi\sqrt{\frac{6l}{7g}}$$

Question: Find direction and magnitude of magnetic field if EMW is travelling along $+z$ axis and \vec{E} is along $-x$ direction.

Options:

(a) $B_0 = \frac{E_0}{C}$

(b) $B_0 = \frac{C}{E_0}$

(c) $B_0 = C$

(d) $B_0 = CE_0$

Answer: (a)

Solution:

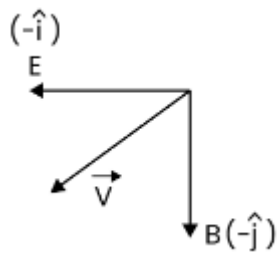

$$B_0 = \frac{E_0}{C}$$

Question: De Broglie wavelength of photon and electron are same, then the ratio of their energy is?

Options:

- (a) $\frac{C}{V}$
- (b) CV
- (c) $\frac{2C}{V}$
- (d) $\frac{2V}{C}$

Answer: (c)

Solution: $\lambda_p = \lambda_e$

$$P_p = P_e$$

$$\frac{E_p}{E_e} = \frac{h_c / \lambda_p}{P_e^2} = \frac{P_p \cdot C}{P_e^2} \cdot 2m$$

$$= \frac{C \cdot 2m}{m \cdot V}$$

$$\frac{E_p}{E_e} = \frac{2C}{V}$$

Question: Carnot cycle works on steam temperature and ice temperature. Find efficiency

Options:

- (a) 0.2
- (b) 0.16
- (c) 0.06
- (d) 0.26

Answer: (d)

$$\text{Solution: } \eta = 1 - \frac{T_c}{T_H}$$

$$= 1 - \frac{273}{373}$$

$$= \frac{100}{373} = 0.26$$

Question: A capacitor C_1 is charged to a potential difference V . The charging battery is then removed and the capacitor is connected to an uncharged capacitor C_2 . The potential difference across the combination is

Options:

(a) $V \frac{C_1}{C_1 + C_2}$

(b) $V \frac{C_2}{C_1 + C_2}$

(c) $V \frac{C_1 C_2}{C_1 + C_2}$

(d) $\frac{V}{C_1 + C_2}$

Answer: (a)

Solution:

Initial the charge $Q = C_1 V$

After removing the battery the both capacitors are in parallel.

So total capacitance $C = C_1 + C_2$

Let the potential difference across the combination is V'

Now charge $Q' = CV' = (C_1 + C_2)V'$

As the total charge is conserved so $Q = Q'$

$$\Rightarrow C_1 V = (C_1 + C_2) V'$$

$$\therefore V' = \frac{C_1 V}{C_1 + C_2}$$

Question: Find the ratio of dynamic resistance at 2V and 4V for a semiconductor device?

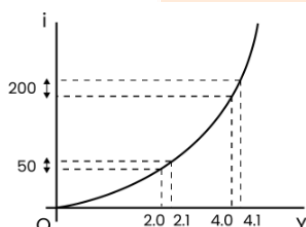

Options:

(a) 4: 1

(b) 2: 1

(c) 1: 1

(d) 3: 2

Answer: (a)

Solution:

$$\text{Dynamic } R = \frac{\Delta V}{\Delta i}$$

$$\frac{R_1}{R_2} = \frac{0.1/50}{0.1/200} = \frac{200}{50} = \frac{4}{1}$$

Question: How many α and β particles are emitted when uranium ${}_{92}^{238}\text{U}$ decays to lead ${}_{82}^{206}\text{Pb}$?

Options:

- (a) $\alpha = 4$ and $\beta = 2$
- (b) $\alpha = 6$ and $\beta = 4$
- (c) $\alpha = 6$ and $\beta = 8$
- (d) $\alpha = 4$ and $\beta = 8$

Answer: (c)

Solution:

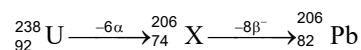

(X is a hypothetical element)

So, 6α particles and 8β particles should decay

Question: If the time period of simple pendulum is T, then find its time period inside a lift moving upward with an acceleration of $g\text{ m/s}^2$

Options:

- (a) T
- (b) 2T
- (c) $\frac{T}{2}$
- (d) $\frac{T}{\sqrt{2}}$

Answer: (d)

Solution:

Time period of the pendulum $T = 2\pi\sqrt{\frac{\ell}{g}}$

So if the pendulum is in the lift and moving toward then net acceleration will be

$$a_{\text{net}} = g + g = 2g$$

So, new time period $T' = 2\pi\sqrt{\frac{\ell}{a_{\text{net}}}}$

$$T' = 2\pi\sqrt{\frac{\ell}{2g}}$$

$$T' = 2\pi\sqrt{\frac{\ell}{g}} \times \frac{1}{\sqrt{2}}$$

$$T' = \frac{T}{\sqrt{2}}$$

Question: Find the net deviation in the given figure.

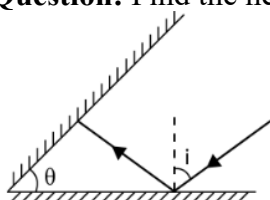

Options:

- (a) 210°
- (b) 10°
- (c) 110°
- (d) 100°

Answer: (a)

Solution:

$$\begin{aligned}\delta_1 &= \pi - 2i \\ \delta_2 &= \pi - 2i' \\ \delta_{\text{net}} &= 2\pi - 2\theta \\ &= 360 - 2(75^\circ) \\ &= 360 - 150^\circ = 210^\circ\end{aligned}$$

Question: In what condition apparent weight of man is lesser than actual weight.

Options:

- (a) $N = Mg$
- (b) $N < Mg$
- (c) $N > Mg$
- (d) $N \neq Mg$

Answer: (b)

Solution:

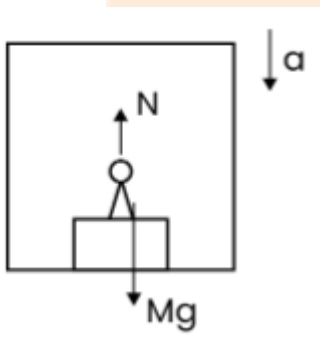

Mans accelerates downwards

$$\begin{aligned}Mg - N &= Ma \\ N &= Mg - Ma \\ N &< Mg\end{aligned}$$

Question: If length of wire increased by 0.4 % s it is stretched, change in resistance = ?

Options:

- (a) 0.4%
- (b) 0.2%
- (c) 0.6%
- (d) 0.8%

Answer: (d)

Solution:

We know

$$R = \frac{\rho \ell}{A}$$

Also, $V = A\ell$

$$A = \frac{V}{\ell} \quad (V = \text{constant})$$

$$\Rightarrow R = \frac{\rho \ell^2}{V}$$

$$\text{So, } \left(\frac{\Delta R}{R} \times 100 \right) = 2 \left(\frac{\Delta \ell}{\ell} \times 100 \right)$$

$$\left(\frac{\Delta R}{R} \times 100 \right) = 2 \times 0.4\%$$

$$= 0.8\%$$



JEE-Main-26-06-2022-Shift-1 (Memory Based)

Chemistry

Question: Which of the following is responsible for the secretion of pepsin?

Options:

- (a) Histamine
- (b) Cimetidine
- (c) Zantac
- (d) Serotonin

Answer: (a)

Solution: Histamine, stimulates the secretion of pepsin and hydrochloric acid in the stomach.

Question: Arrange the following species in increasing order of their Bond Order O_2^- , O_2^{2-} , O_2 , O_2^+

Options:

- (a) $O_2^- < O_2 < O_2^+ < O_2^{2-}$
- (b) $O_2 < O_2^- < O_2^+ < O_2^{2-}$
- (c) $O_2^+ < O_2^- < O_2 < O_2^{2-}$
- (d) $O_2^{2-} < O_2^- < O_2 < O_2^+$

Answer: (d)

Solution: Electronic configuration of O_2

$(\sigma 1s^2) (\sigma^* 1s^2) (\sigma 2s^2) (\sigma^* 2s^2) (\sigma 2p_z^2) (\pi 2p_x^2) (\pi 2p_y^2) (\pi^* 2p_x^1) (\pi^* 2p_y^1)$

$$\text{Bond order of } O_2 = \frac{N_B - N_A}{2} = \frac{10 - 6}{2} = 2$$

$$\text{Bond order of } O_2^- = \frac{10 - 7}{2} = \frac{3}{2} = 1.5$$

$$\text{Bond order of } O_2^+ = \frac{10 - 5}{2} = 2.5$$

$$\text{Bond order of } O_2^{2-} = \frac{10 - 8}{2} = 1$$

Increasing order of bond order is $O_2^{2-} < O_2^- < O_2 < O_2^+$

Question: The increasing order of stability of +1 oxidation state of group 13 elements is:

Options:

- (a) $Ga < Al < In < Tl$
- (b) $Tl < In < Ga < Al$
- (c) $Al < Ga < Tl < In$
- (d) $Al < Ga < In < Tl$

Answer: (d)

Solution: On going down the group 13, stability of +1 oxidation state increases due to inert pair effect.

Question: The correct order of melting point of group 16 elements is:

Options:

- (a) $O < S < Se < Te > Po$
- (b) $Po < S < Se < Te < O$
- (c) $S < O < Se < Te < Po$
- (d) $Te < O < Po < Se < S$

Answer: (a)

Solution: As we go down the group as the metallic character increases, the melting point increases for group 16 elements. But due to its packed structure and lesser shielding of electrons, Te has the highest melting point among them. So, the correct order is $O < S < Se < Te > Po$

Question: Which of the following alkaline earth metal has highest melting point?

Options:

- (a) Be
- (b) Mg
- (c) Ca
- (d) Sr

Answer: (a)

Solution:

Melting point of Be is 1560

Melting point of Mg is 924

Melting point of Ca is 1124

Melting point of Sr is 1062

Question: $A + \text{Alkali} \rightarrow B$, where B is an oxyacid of Phosphorus with no P-H bonds, what is A?

Options:

- (a) White Phosphorus
- (b) Red Phosphorus
- (c) H_3PO_3
- (d) P_2O_5

Answer: (b)

Solution:

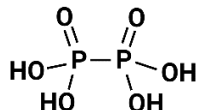

Red P_4 + Alkali \rightarrow Hypophosphoric acid

(A)

(B)

Question: Among V_2O_3 , V_2O_5 and V_2O_4 , calculate magnetic moment of the most basic oxide.

Options:

- (a) $2\sqrt{2}$
- (b) $\sqrt{2}$
- (c) $2\sqrt{3}$

(d) 2

Answer: (a)

Solution:

Most basic is $V_2O_3 \rightarrow V^{3+}$

${}_{23}V \rightarrow 4s^2 3d^3, V^{3+} = 3d^2$

$\mu = \sqrt{2(2+2)} = \sqrt{8}$ BM

Question: Which of the following has maximum enol content?

Options:

(a)

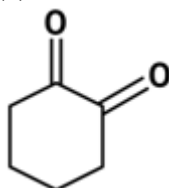

(b)

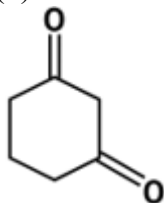

(c)

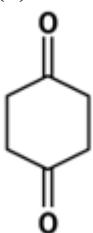

(d)

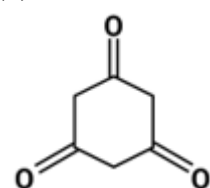

Answer: (d)

Solution: Cyclohexane-1,3,5-trione on tautomerisation forms resonance stabilized molecule benzene-1,3,5-triol. Hence, enol content is maximum.

Question: The intermediate in the given reaction is



Options:

(a)

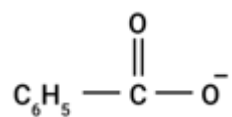

(b)

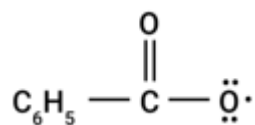

(c)

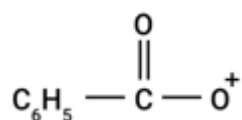

(d)

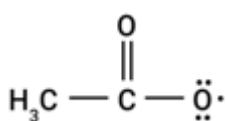

Answer: (b)

Solution:

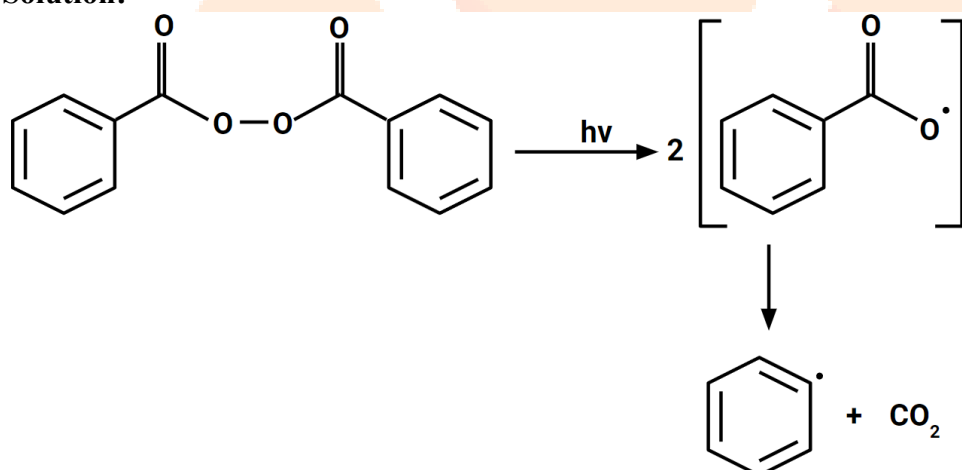

Question:

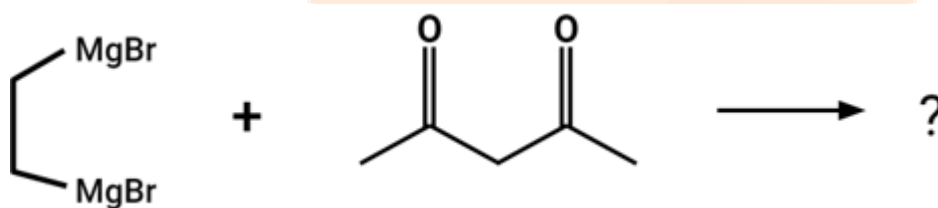

Options:

(a)

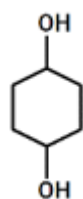

(b)

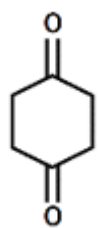

(c)

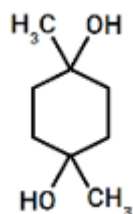

(d)

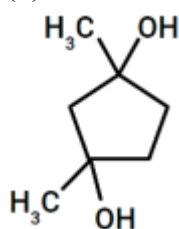

Answer: (d)

Solution:

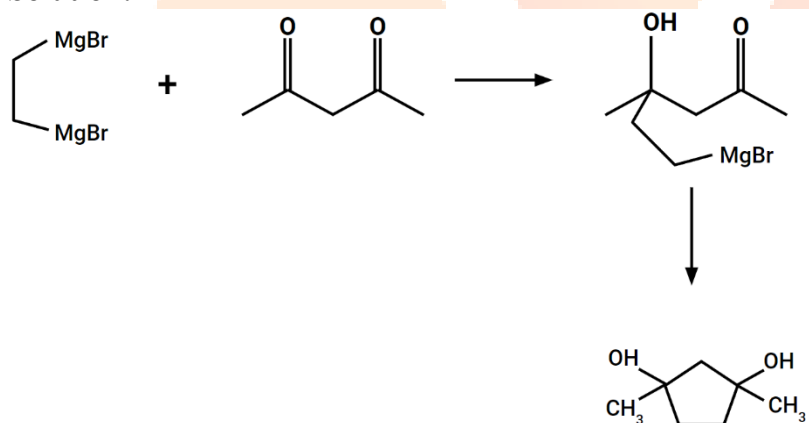

Question: Which of the following is produced in stratostrophic clouds?

Options:

- (a) Smog
- (b) Ozone hole
- (c) Acid rain
- (d) Carbon dioxide

Answer: (b)

Solution: Ozone hole is produced by stratostrophic cloud

Question: If the Bohr radius of 3rd orbit of H-atom is r_3 and that of 4th orbit is r_4 then

Options:

- (a) $r_4 = \frac{16}{9}r_3$

$$(b) r_4 = \frac{4}{3}r_3$$

$$(c) r_4 = \frac{9}{16}r_3$$

$$(d) r_4 = \frac{3}{4}r_3$$

Answer: (a)

Solution:

$$r \propto \frac{n^2}{z}$$

$z = 1$ for hydrogen

$$r_3 \propto 9$$

$$r_4 \propto 4^2 = 16$$

$$\frac{r_3}{r_4} = \frac{9}{16}$$

$$r_4 = \frac{16}{9}r_3$$

Question: On electrolysis of HSO_4^- , compound is formed which on hydrolysis forms 'X'. What is the dihedral angle of X in solid state?

Answer: 90.20

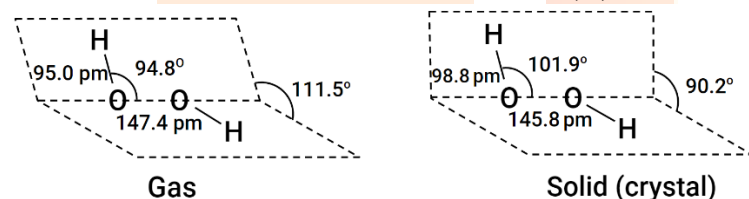
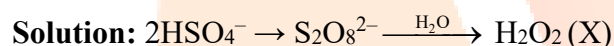

Question: Weight of evacuated glass vessels is 40 g. Weight when a liquid of density 0.95 g/mL is 135 g. When gas is put at 0.82 atm pressure and 250 K temp weight is 40.5 g, then find the molar mass of the gas in (g).

Answer: 125.00

Solution:

$$\text{Weight of liquid} = 135 - 40 = 95 \text{ g}$$

$$\text{Volume of liquid} = \frac{\text{mass}}{\text{density}} = \frac{95}{0.95} = 100 \text{ mL}$$

$$\text{Volume of vessel} = 100 \text{ mL}$$

$$PV = nRT$$

$$0.82 \times \frac{100}{1000} = nRT$$

$$n = \frac{0.82 \times \frac{100}{1000}}{0.0821 \times 250} = \frac{0.082}{0.0821 \times 250} = \frac{1}{250}$$

$$\text{Mass of ideal gas} = 40.5 - 40 = 0.5 \text{ g}$$

$$n = \frac{w}{M} = \frac{1}{250}$$

$$\frac{0.5}{M} = \frac{1}{250}$$

$$\text{Molar mass} = 0.5 \times 250 = 125 \text{ g}$$

Question: An organic compound when reacts with dil. HNO_3 produces two isomers A and B. A possess intramolecular hydrogen bonding and B possess intermolecular hydrogen bonding. When the same compound reacts with conc. HNO_3 it produces a strong acid D. Find the no. of oxygen atoms in D.

Answer: 7.00

Solution:

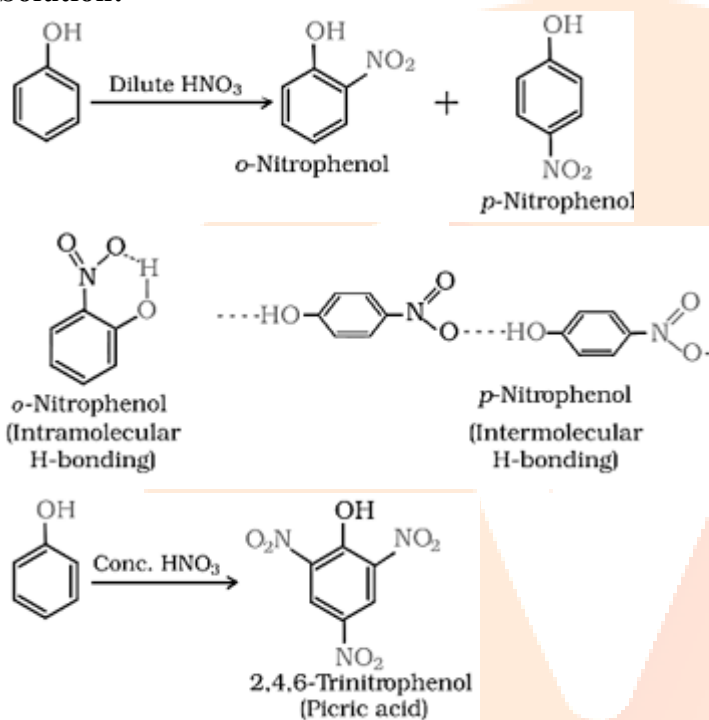

JEE-Main-26-06-2022-Shift-1 (Memory Based)

MATHEMATICS

Question: Normal to $y^2 = 6x$ at P, passes through (5, -8). Find ordinate of point of intersection of directrix & tangent at P.

Answer: $-\frac{9}{4}$

Solution:

Given, $y^2 = 6x$

So, $a = \frac{3}{2}$

Thus equation of directrix is $x = -\frac{3}{2}$

Now, equation of normal be

$$tx + y = 2at + at^3$$

It pass through (5, -8)

$$\text{Then } 5t - 8 = 2\left(\frac{3}{2}\right)t + \frac{3}{2}t^3$$

$$5t - 8 = 3t + \frac{3}{2}t^3$$

$$10t - 16 = 6t + 3t^3$$

$$\Rightarrow 3t^3 - 4t + 16 = 0$$

$$\Rightarrow 3t^2(t+2) - 6t(t+2) + 8(t+2) = 0$$

$$(t+2)(3t^2 - 6t + 8) = 0$$

$$\therefore t = -2$$

Equation of tangent

$$ty = x + at^2$$

$$-2y = -x + \left(\frac{3}{2}\right)(4)$$

$$-2y = x + 6$$

$$\therefore \text{Intersecting point } -2y = -\frac{3}{2} + 6$$

$$y = \frac{3}{4} - 3$$

$$= \frac{-9}{4}$$

Question: A biased coin is tossed 5 times, probability of 4 heads = probability of 5 heads then probability of atmost 2 heads.

Answer: $\frac{46}{6^4}$

Solution:

Let p be the probability of getting head

And q be the probability of getting tail

i.e., such that $p + q = 1$

Now, according to question

$${}^5C_4 p^4 q^1 = {}^5C_5 p^5$$

$$\Rightarrow 5(1-p) = p$$

$$p = \frac{5}{6}$$

Now, probability of atleast 2 heads

$$= {}^5C_0 q^5 + {}^5C_1 p^1 q^4 + {}^5C_2 p^2 q^3$$

$$= \left(\frac{1}{6}\right)^5 + 5\left(\frac{5}{6}\right)\left(\frac{1}{6}\right)^4 + 10\left(\frac{5}{6}\right)^2\left(\frac{1}{6}\right)^3$$

$$= \frac{1}{6^5}(1 + 5^2 + 250)$$

$$= \frac{276}{6^5} = \frac{46}{6^4}$$

Question: If $\frac{x}{a} + \frac{y}{b} = 1$ is tangent to $\left(\frac{x}{a}\right)^n + \left(\frac{y}{b}\right)^n = 1$ then $n \in$ ____

Answer: (0)

Solution:

$$\text{Given, } \left(\frac{x}{a}\right)^n + \left(\frac{y}{b}\right)^n = 1$$

$$\Rightarrow n\left(\frac{x}{a}\right)^{n-1} \frac{1}{a} + n\left(\frac{y}{b}\right)^{n-1} \frac{1}{b} \frac{dy}{dx} = 0$$

$$\frac{dy}{dx} = -\frac{b}{a} \left(\frac{xb}{ya}\right)^{n-1}$$

At (a, b)

$$\frac{dy}{dx} = -\frac{b}{a}$$

Equation of tangent

$$(y - b) = \frac{-b}{a}(x - a)$$

$$\frac{y}{b} - 1 = -\frac{x}{a} + 1$$

$$\frac{x}{a} + \frac{y}{b} = 2$$

Thus, for number of value of 'n', $\frac{x}{a} + \frac{y}{b} = 1$ is tangent.

Question: If $A = \{x : \text{HCF}\{x, 45\} = 1\}$ & $B = \{x = 2k; 1 \leq k \leq 100\}$ then $A \cap B =$

Answer: 53.00

Solution:

$$B = \{x = 2k; 1 \leq k \leq 100\}$$

Thus, $x \in \{2, 4, 6, 8, 10, \dots, 100\}$

$$B = \{2, 4, 6, 8, 10, 12, \dots, 200\}$$

Thus, $n(B) = 100$

$$\text{Now, } A = \{x : \text{HCF}\{x, 45\} = 1\}$$

Thus, multiple of 5 and 3 should not be there

$$\text{Thus, } A = \{1, 2, 4, 7, 8, 11, 13, 4, \dots\}$$

Thus, $A \cap B$ will contain elements in B which are not multiple of 2 and 5, i.e., 10, 20, ... 200

Thus, total 20

And not multiple of 3 and 2 i.e., 6, 12, 18, ..., 198

Thus, total $33 - 6 = 27$

Thus, $n(A \cap B) = 100 - 47 = 53$

Question: Find remainder when 2021^{2023} is divided by 7.

Answer: 5.00

Solution:

Given, 2021^{2023}

$$\Rightarrow (2016 + 5)^{2023}$$

$$\Rightarrow {}^{2023}C_0 2016^{2023} + \dots + {}^{2023}C_{2022} (2016)(5)^{2022} + 5^{2023}$$

$$\Rightarrow 7(\text{Integer}) + 5^{2023}$$

$$\text{Now, } 5^{2023} = 5(5^2)^{674}$$

$$= 5(126 - 1)^{674}$$

$$= 5 \left[{}^{674}C_0 (126)^{674} + \dots + 1 \right]$$

$$= 5[7 \text{ Integer} + 1]$$

$$= 7(\text{Integer}) + 5$$

Thus remainder is 5

Question: The point P(3, 7) is one of the vertices of an equilateral ΔPQR & $x + y = 5$ is the equation of QR, then area of ΔPQR is:

Answer: $\frac{25}{2\sqrt{3}}$

Solution:

Given, one vertex (3, 7)

$$\therefore h = \left| \frac{10-5}{\sqrt{2}} \right| = \frac{5}{\sqrt{2}}$$

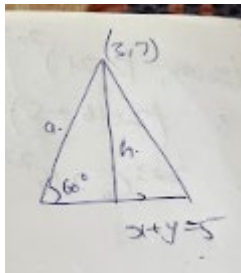

Also, $\sin 60^\circ = \frac{4}{9}$

$$a = \frac{h}{\sin 60^\circ} = \frac{5}{\sqrt{2}} \cdot \frac{2}{\sqrt{3}} = \frac{5\sqrt{2}}{\sqrt{3}}$$

$$\therefore \text{Area of } \Delta = \frac{\sqrt{3}}{4} \left(\frac{5\sqrt{2}}{\sqrt{3}} \right)^2$$

$$= \frac{25}{2\sqrt{3}}$$

Question: $\lim_{x \rightarrow \frac{1}{\sqrt{2}}} \frac{\sin(\cos^{-1} x) - x}{1 - \tan(\cos^{-1} x)} = ?$

Answer: $-\frac{1}{\sqrt{2}}$

Solution:

Given, $\lim_{x \rightarrow \frac{1}{\sqrt{2}}} \frac{\sin(\cos^{-1} x) - x}{1 - \tan(\cos^{-1} x)}$

Applying L-Hospital rule

$$\lim_{x \rightarrow \frac{1}{\sqrt{2}}} \frac{\cos(\cos^{-1} x) \left(\frac{-1}{\sqrt{1-x^2}} \right) - 1}{-\sec^2 x (\cos^{-1} x)} = \frac{\frac{1}{\sqrt{2}}(-\sqrt{2}) - 1}{2(-\sqrt{2})}$$

$$= \frac{-2}{2\sqrt{2}} = -\frac{1}{\sqrt{2}}$$

Question: If $\bar{a} \cdot b = 1$, $\bar{b} \cdot \bar{c} = 2$ & $\bar{c} \cdot \bar{a} = 3$ then $[\bar{a} \times (\bar{b} \times \bar{c}), \bar{b} \times (\bar{c} \times \bar{a}), \bar{c} \times (\bar{b} \times \bar{a})] = ?$

Answer: 0.00

Solution:

Given, $[a \times (b \times c) \quad b \times (c \times a) \quad c \times (b \times a)]$

$$\Rightarrow \{(a \times (b \times c)) \times (b \times (c \times a))\} \cdot (c \times (b \times a))$$

$$\Rightarrow \{((\bar{a} \cdot \bar{c})\bar{b} - (\bar{a} \cdot \bar{b})\bar{c}) \times (\bar{b} \cdot \bar{a})\bar{c} - (\bar{b} \cdot \bar{c})\bar{a}\} \cdot ((\bar{c} \cdot \bar{a})\bar{b} - (\bar{c} \cdot \bar{b})\bar{a})$$

$$\Rightarrow \{(3\bar{b} - \bar{c}) \times (\bar{c} - 2\bar{a})\} \cdot (3\bar{b} - 2\bar{a})$$

$$\Rightarrow \{3(b \times c) - 6(\bar{b} \times \bar{a}) - 0 + 2(\bar{c} \times \bar{a})\} \cdot (3\bar{b} - 2\bar{a})$$

$$\Rightarrow 6(c \times a) \cdot b - 6(b \times c) \cdot a$$

$$\Rightarrow 6[a \quad b \quad c] - 6[a \quad b \quad c] = 0$$

Question: From 10 Boys & 5 Girls, in how many we can select 3 boys & 3 girls such that B_1 & B_2 are not together in a group.

Answer: 1120.00

Solution:

8 Boys	2 Boys	5 Girls
3		3
2	1	3

$$\text{Number of ways} = {}^8C_3 \times {}^5C_3 + {}^8C_2 \times {}^2C_1 \times {}^5C_3$$

$$= 560 + 560$$

$$= 1120$$

Question: If $\sin^2 10 \times \sin 20 \times \sin 40 \times \sin 50 \times \sin 70 = \alpha - \frac{\sin 10}{16}$. Find α .

Answer: $\frac{1}{64}$

Solution:

Given, $\sin^2 10 \times \sin 20 \times \sin 40 \times \sin 50 \times \sin 70$

$$\Rightarrow \sin 10 \times \cos 160 \times \cos 140 \times \cos 40 \times \cos 20 \times \cos 80$$

$$\sin 10 [\cos 20 \cdot \cos 40 \cdot \cos 80 \cdot \cos 160] \sin 40$$

$$\sin 10 \left[\frac{\sin 2^4 10}{2^4 \sin 10} \right] \sin 40$$

$$\begin{aligned} & \sin 10 \left[\frac{\sin 160}{16 \sin 10} \right] \sin 40 \\ & \frac{\sin 10 \sin 20 \sin 40}{16 \sin 10} \\ & \Rightarrow \frac{1}{32} (2 \sin 20 \sin 40) \\ & \Rightarrow \frac{1}{32} (\cos(40-20) - \cos(40+20)) \\ & \Rightarrow \frac{1}{32} (\cos 20 - \cos 60) \\ & \frac{\cos 20}{32} - \frac{1}{64} \\ & \frac{102 \sin^2 10}{32} - \frac{1}{64} \\ & \frac{1}{32} - \frac{1}{64} - \frac{1}{16} (\sin^2 10) \\ & \frac{1}{64} - \frac{\sin^2 10}{16} \end{aligned}$$

Thus, $\alpha = \frac{1}{64}$

Question: If mean of $a, b, 8, 5, 10$ is 6 & variance is 6.8 then find 25M, where M is mean deviation about mean.

Answer: 60.00

Solution:

$$\text{Given, } \bar{x} = \frac{a+b+8+5+10}{5} = 6$$

$$a+b+23=30$$

$$a+b=7 \quad \dots(1)$$

$$\text{Variance} = \frac{\sum (x_i)^2}{5} - (\bar{x})^2$$

$$6.8 = \frac{a^2 + b^2 + 64 + 25 + 100}{5} - 36$$

$$(42 \cdot 8)5 = a^2 + b^2 + 189$$

$$a^2 + b^2 = 25 \quad \dots(2)$$

Thus, $a = 4$ and $b = 3$

$$\text{Thus, mean deviation} = \frac{\sum |x_i - \bar{x}|}{5}$$

$$= \frac{2+3+2+1+4}{5}$$

$$M = \frac{12}{5}$$

$$\therefore 25M = 25\left(\frac{12}{5}\right) = 60$$

Question: If $|\text{adj } 24A| = |\text{adj } 3(\text{adj}(2A))|$ & A is 3×3 , then $|A|^2$ is ____

Answer: 64.00

Solution:

$$|\text{adj } A| = |A|^{n-1} \text{ \& } |kA| = k^n |A|$$

$$\Rightarrow |24A|^{3-1} = |3 \text{ adj } 2A|^{3-1}$$

$$\Rightarrow (24^3)^2 |A|^2 = (3^3)^2 |\text{adj } 2A|^2$$

$$24^6 |A|^2 = 3^6 (|2A|^2)^2$$

$$24^6 |A|^2 = 3^6 (2^3)^4 |A|^4$$

$$24^6 |A|^2 = 3^6 \cdot 8^4 |A|^4$$

$$3^6 \times 8^6 |A|^2 = 3^6 8^4 |A|^4$$

$$|A|^2 = 8^2 = 64$$