

26/07/2022

Evening



Corporate Office : Aakash Tower, 8, Pusa Road, New Delhi-110005 | Ph.: 011-47623456

Memory Based Answers & Solutions

Time : 3 hrs.

for

M.M. : 300

JEE (Main)-2022 (Online) Phase-2

(Physics, Chemistry and Mathematics)

IMPORTANT INSTRUCTIONS:

- (1) The test is of **3 hours** duration.
- (2) The Test Booklet consists of 90 questions. The maximum marks are 300.
- (3) There are **three** parts in the question paper consisting of **Physics, Chemistry** and **Mathematics** having 30 questions in each part of equal weightage. Each part (subject) has two sections.
 - (i) **Section-A:** This section contains 20 multiple choice questions which have only one correct answer. Each question carries **4 marks** for correct answer and **-1 mark** for wrong answer.
 - (ii) **Section-B:** This section contains 10 questions. In Section-B, attempt any **five questions out of 10**. The answer to each of the questions is a numerical value. Each question carries **4 marks** for correct answer and **-1 mark** for wrong answer. For Section-B, the answer should be rounded off to the nearest integer.

PHYSICS

SECTION - A

Multiple Choice Questions: This section contains 20 multiple choice questions. Each question has 4 choices (1), (2), (3) and (4), out of which **ONLY ONE** is correct.

Choose the correct answer:

1.

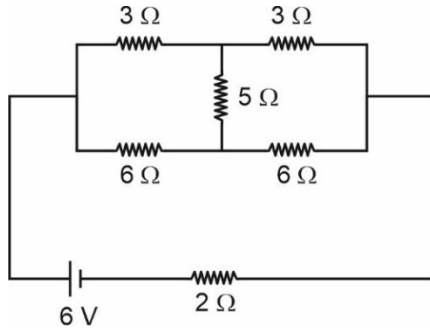

Current through the cell in the circuit is

- (1) 1A (2) 2A
(3) 0A (4) 3A

Answer (1)

Sol. The shown circuit is a balanced wheat stone bridge with equivalent circuit as

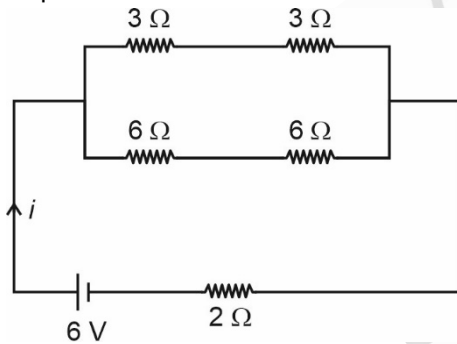

$R_{eq} = 6 \Omega$

$i = \frac{6}{6} A = 1A$

2.

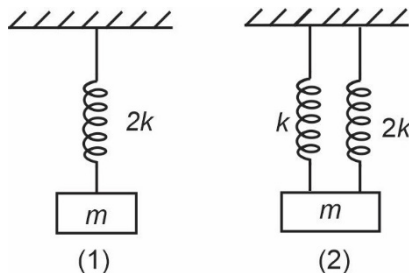

The ratio of time period of oscillation of system (1) to that of system (2) is

- (1) $\sqrt{3}$ (2) $\sqrt{\frac{3}{2}}$
(3) $\sqrt{\frac{2}{3}}$ (4) $\sqrt{\frac{1}{3}}$

Answer (2)

Sol. $T_1 = 2\pi\sqrt{\frac{m}{2k}}$

$T_2 = 2\pi\sqrt{\frac{m}{2k+k}}$

$= 2\pi\sqrt{\frac{m}{3k}}$

$= \frac{T_1}{T_2} = \sqrt{\frac{3}{2}}$

3. Particle A and particle B are projected at angle 45° and 30° respectively at same speed. Ratio of the range of two projectiles i.e. $\frac{R_A}{R_B}$ is

- (1) $\frac{1}{2}$ (2) $\sqrt{\frac{3}{2}}$
(3) $\frac{2}{\sqrt{3}}$ (4) $\frac{2}{1}$

Answer (3)

Sol. $\frac{R_A}{R_B} = \frac{u_A^2 \sin 2\theta_A \times g}{g \times u_B^2 \sin 2\theta_B}$
 $= \frac{\sin(90^\circ)}{\sin(60^\circ)} = \frac{2}{\sqrt{3}}$

4. In the shown system in case (1) $m_1 = 2m_2$ while in case (2) $m_1 = 3m_2$ then acceleration in case (1) would be _____ times that of acceleration in case (2) when set free.

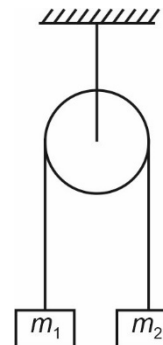

- (1) $\frac{1}{3}$ (2) $\frac{3}{2}$
(3) 3 (4) $\frac{2}{3}$

Answer (4)

Sol. $a_1 = \frac{m_1 - m_2}{m_1 + m_2} g = \frac{g}{3}$

$$a_2 = \frac{m_1 - m_2}{m_1 + m_2} g = \frac{g}{2}$$

$$\Rightarrow a_1 = \frac{2}{3} a_2$$

5. The velocity of particle is $\frac{1}{3}$ of the escape velocity.

Then find the maximum height reached by the body?

(1) $\frac{R}{4}$ (2) $\frac{R}{3}$

(3) $\frac{R}{9}$ (4) $\frac{R}{8}$

Answer (4)

Sol. Total energy of the body at surface of earth

$$= -\frac{GMm}{R} + \frac{GMm}{9R} = -\frac{8GMm}{9R}$$

Total energy at the highest point

$$\frac{GMm}{R+h} = -\frac{8GMm}{9R}$$

$$\Rightarrow R+h = \frac{9R}{8} \text{ or } h = \frac{R}{8}$$

6. Two spherical conductors are charged and then connected by a conducting wire. At equilibrium the ratio of electric field on surface of first sphere to that of the second sphere is (Radius of first sphere = 5 cm, Radius second sphere = 10 cm)

(1) 1 : 2 (2) 1 : 4

(3) 4 : 1 (4) 2 : 1

Answer (4)

Sol. At equilibrium $V_1 = V_2$

$$\frac{KQ_1}{R_1} = \frac{KQ_2}{R_2} \Rightarrow Q \propto R$$

$$\text{and } \frac{E_1}{E_2} = \frac{KQ_1/R_1^2}{KQ_2/R_2^2} = \frac{R_2}{R_1}$$

$$= \frac{10}{5} = 2$$

7. If ratio of mass number of two nuclei is $\frac{4}{3}$ then ratio of their radii in same order would be

(1) $\frac{4}{3}$ (2) $\frac{3}{4}$

(3) $\left(\frac{4}{3}\right)^{\frac{1}{3}}$ (4) $\left(\frac{3}{4}\right)^{\frac{2}{3}}$

Answer (3)

Sol. $\frac{A_1}{A_2} = \frac{4}{3}$

Now $R_1 \propto A_1^{\frac{1}{3}}$

$$\Rightarrow \frac{R_1}{R_2} = \left(\frac{A_1}{A_2}\right)^{\frac{1}{3}}$$

$$= \left(\frac{4}{3}\right)^{\frac{1}{3}}$$

8. A particle at rest breaks down in two parts of masses $\frac{M}{3}$ and $\frac{2M}{3}$. The ratio of de-Broglie wavelength of two parts is equal to

(1) 2 : 1 (2) 1 : 1

(3) 1 : 3 (4) 1 : 1

Answer (2)

Sol. As momentum of both the particle is same to maintain the net momentum of system equal to zero. So ratio of de-Broglie wavelength would be equal to 1.

9. In an AM signal maximum amplitude of wave is 60 V while minimum amplitude is 20 V. The percentage modulation index is equal to

(1) 24 (2) 50

(3) 30 (4) 33

Answer (2)

Sol. $\mu = \frac{60 - 20}{60 + 20} \times 100\%$

$$\mu = 50\%$$

10. When jaws are closed of a vernier calliper the zero of vernier scale lies just left of the zero of the main scale with 4th VSD coinciding. On measuring the diameter of a sphere with this calliper the zero of vernier scale lies between 30 and 31st division of main scale with 6th division of vernier scale coinciding, the diameter of sphere is

(1) 3.16 cm (2) 3.13 cm

(3) 3.12 cm (4) 3.22 cm

Answer (3)

Sol. Zero error = -0.6 mm

$$\begin{aligned} \text{Reading} &= 3.0 \text{ cm} + 6(0.01 \text{ cm}) - (\text{zero error}) \\ &= 3.0 + 0.06 \text{ cm} + 0.06 \text{ cm} \\ &= 3.12 \text{ cm} \end{aligned}$$

11. A cube of ice of dimensions (60 cm × 50 cm × 20 cm) is enclosed by wall of thickness 1 cm and conductivity 0.05 J/m-°C. With surrounding temperature 40°C, the rate of melting of ice is equal to ($L_{\text{fusion}} = 80 \text{ cal/g}$)

- (1) 30 g/s (2) 62 g/s
 (3) 80 g/s (4) 94 g/s

Answer (2)

Sol. Total area = $2(60 \times 50 + 50 \times 20 + 20 \times 60) \text{ cm}^2$
 = 10400 cm²

$$\Rightarrow R_{th} = \frac{10^{-2}}{0.05 \times 10400 \times 10^{-4}} = \frac{20 \times 10^{-2}}{1.04}$$

$$\Delta T = 40$$

$$\Rightarrow \frac{40}{0.2} \times 1.04 = \frac{dm}{dt} \times (30) \times 4.2 \times 10^3$$

$$\Rightarrow \frac{dm}{dt} = 6.2 \times 10^{-4} \text{ kg/s} = 62 \text{ g/s}$$

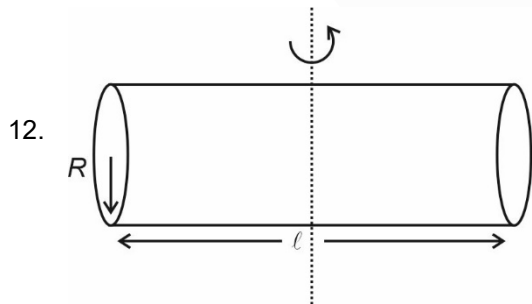

12.

The moment of inertia of the solid cylinder (mass m) about the shown axis is equal to

- (1) $\frac{m}{3}(R^2 + l^2)$ (2) $\frac{m}{4}\left(R^2 + \frac{l^2}{3}\right)$
 (3) $\frac{m}{4}(R^2 + l^2)$ (4) $\frac{m}{3}\left(R^2 + \frac{l^2}{4}\right)$

Answer (2)

Sol. Moment of inertia = $\frac{m l^2}{12} + \frac{m R^2}{4}$

$$= \frac{m}{4} \left(\frac{l^2}{3} + R^2 \right)$$

13. A particle ${}_{22}^{48}\text{X}^{3+}$ has number of neutrons x more than that of number of electrons then x is

- (1) 11 (2) 4
 (3) 7 (4) 2

Answer (3)

Sol. Number of neutrons = $48 - 22$
 = 26

Number of electrons = $22 - 3 = 19$

$$\Rightarrow x = 26 - 19 = 7$$

14. Find out elongation in rod due to self weight in terms of (m, y, L, A)

- (1) $\frac{Mgl}{Ay}$
 (2) $\frac{Mgl}{2Ay}$
 (3) $\frac{3Mgl}{2Ay}$
 (4) $\frac{2Mgl}{3Ay}$

Answer (2)

Sol. Elongation in the rod due to self weight

$$\begin{aligned} &= \int_0^l \frac{Mgx}{l} dx \times \frac{1}{Ay} \\ &= \frac{Mgl^2}{2Ay} \\ &= \frac{Mgl}{2Ay} \end{aligned}$$

15. If the ray moves grazing the second surface of an equilateral prism. Find the refractive index of medium if the μ of prism is 1.5

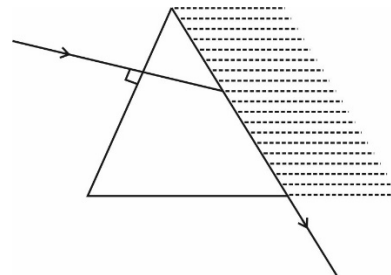

- (1) $\frac{\sqrt{3}}{\sqrt{2}}$ (2) $\frac{3}{\sqrt{2}}$
 (3) $\frac{3\sqrt{3}}{4}$ (4) $\frac{4\sqrt{2}}{3}$

Answer (3)

Sol. Applying snell's law on second surface

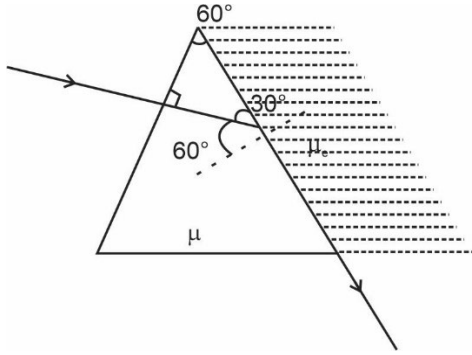

$$\mu_1 \times \sin 90^\circ = \mu \sin 60^\circ$$

$$\Rightarrow \mu_1 = 1.5 \times \frac{\sqrt{3}}{2}$$

$$\mu_1 = \frac{3\sqrt{3}}{4}$$

16. Ball A has its mass $\frac{2}{3}$ times that of ball B. If same force is applied to both the balls then ratio of acceleration of ball A to that of ball B is equal to

- (1) $\frac{1}{3}$ (2) $\frac{2}{3}$
 (3) $\frac{3}{2}$ (4) $\frac{1}{2}$

Answer (3)

Sol. $F = ma$

$$\Rightarrow \frac{a_A}{a_B} = \frac{m_B}{m_A} = \frac{3}{2}$$

17.

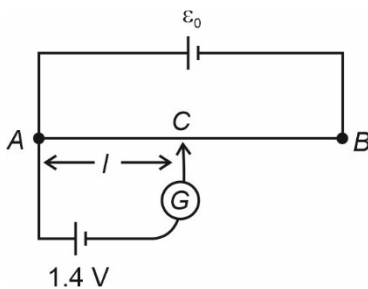

In the shown potentiometer the cell of emf 1.4 V is balanced at point C, 60 cm away from A. Then ϵ_0 is equal to ($AB = 3$ m)

- (1) 1 V (2) 7 V
 (3) 4 V (4) 11 V

Answer (2)

Sol. $\epsilon_0 \left(\frac{0.6}{3} \right) = 1.4$

$$\Rightarrow \epsilon_0 = \frac{1.4 \times 3}{0.6} = 7 \text{ V}$$

18. Two concentric coils with radii $R_1 = 30$ cm and $R_2 = 50$ cm are placed in XY plan with $I = 7$ A. Net magnetic moment is equal to

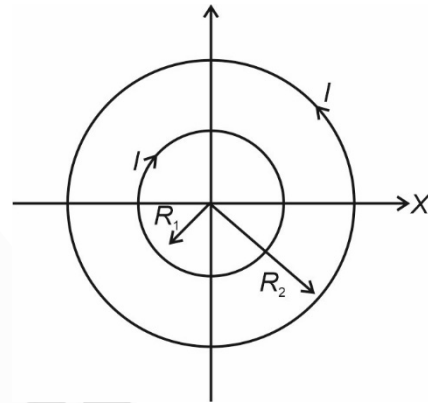

- (1) 1.16 Am² (2) 3.52 Am²
 (3) 7.56 Am² (4) 4.32 Am²

Answer (2)

Sol. $\vec{M} = I(\pi R_2^2 - \pi R_1^2) \hat{k}$
 $= I \left(\frac{22}{7} \right) (40)^2 \times 10^{-4}$
 $= \frac{22 \times 16}{100} \text{ Am}^2$
 $= 3.52 \text{ Am}^2$

19. With switch S closed the energy stored in system is ϵ_1 . Now the switch is opened and dielectric slab of $K = 5$ is inserted in both the capacitors. Now the energy stored in system becomes ϵ_2 . $\frac{\epsilon_1}{\epsilon_2}$ is equal to

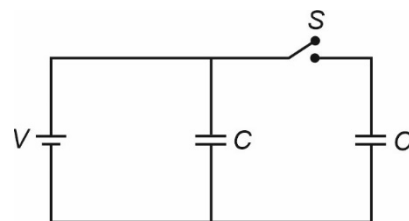

- (1) $\frac{12}{7}$
- (2) $\frac{5}{13}$
- (3) $\frac{7}{12}$
- (4) $\frac{14}{9}$

Answer (2)

Sol. $\epsilon_1 = 2 \times \frac{1}{2} CV^2 = CV^2$

$$\begin{aligned} \epsilon_2 &= \frac{1}{2}(5) CV^2 + \frac{1}{2} \frac{CV^2}{5} \\ &= \left(\frac{26}{10}\right) CV^2 \end{aligned}$$

$$\frac{\epsilon_1}{\epsilon_2} = \frac{1}{26/10} = \frac{5}{13}$$

20. In a transistor the graph between collector current and base current is as shown. If input resistance is equal to 500Ω and output resistance is equal to 2000Ω then voltage gain is equal to

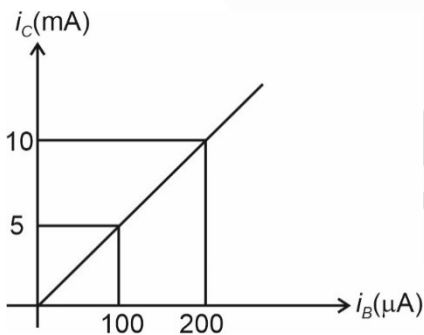

- (1) 50
- (2) 20
- (3) 100
- (4) 200

Answer (4)

Sol. Voltage gain = (current gain) $\left(\frac{R_{out}}{R_{in}}\right)$

$$= \frac{5 \times 10^{-3}}{100 \times 10^{-6}} \times (4) = 200$$

SECTION - B

Numerical Value Type Questions: This section contains 10 questions. In Section B, attempt any five questions out of 10. The answer to each question is a **NUMERICAL VALUE**. For each question, enter the correct numerical value (in decimal notation, truncated/rounded-off to the second decimal place; e.g. 06.25, 07.00, -00.33, -00.30, 30.27, -27.30) using the mouse and the on-screen virtual numeric keypad in the place designated to enter the answer.

21. The bullet (mass = 1.5 kg) hits the wall with $V = 24$ m/s and without change in magnitude it reverses back and force calculated was 100 N. Then the time of impact of bullet with wall was $\underline{\hspace{2cm}} \times 10^{-2}$ s.

Answer (72)

Sol. Change in momentum of bullet = $2 \times v \times m$
 $= 2 \times 24 \times (1.5)$

As the force applied during collision is equal to 100 N and if t is the duration of collision so

$$(100 \times t) = 2 \times 24 \times 1.5$$

$$\text{or } t = \frac{72}{100} \text{ s}$$

22. ${}^2_1X + {}^2_1X \rightarrow {}^4_2Y$

B.E. per nucleon for X = 1.1 MeV

B.E. per nucleon for Y = 7.6 MeV

Find out energy released during process.

Answer (26)

Sol. Total binding energy of reactants
 $= 4 \times 1.1 = 4.4$ MeV

Total binding energy of products
 $= 4 \times 7.6$ MeV

Q Value = $4(7.6 - 1.1)$ MeV
 $= 4 \times 6.5 \text{ eV} = 26$ MeV

- 23.
- 24.
- 25.
- 26.
- 27.
- 28.
- 29.
- 30.

CHEMISTRY

SECTION – A

Multiple Choice Questions: This section contains 20 multiple choice questions. Each question has 4 choices (1), (2), (3) and (4), out of which **ONLY ONE** is correct.

Choose the correct answer :

1. Which group-13 element has the lowest melting point and is close to metalloid?

- (1) Al (2) Ga
(3) In (4) Tl

Answer (2)

Sol. In group-13, Gallium has the lowest melting point as it exists as Ga₂ molecules. There are weak vander Waal's force of attraction between Ga₂ molecules. Gallium is also close to a metalloid.

2. Consider the following statements :

Assertion: Boric acid is a weak acid in aqueous solution.

Reason: It acts as a Lewis acid due to the presence of incomplete octet of boron.

- (1) Assertion is correct, Reason is correct and Reason is the correct explanation for Assertion
(2) Assertion is correct, Reason is correct, but Reason is not the correct explanation
(3) Assertion is correct and Reason is incorrect
(4) Assertion is incorrect and Reason is correct

Answer (2)

Sol. Assertion is correct as Boric acid is a weak acid.

Reason is also correct as it acts as a Lewis acid due to incomplete octet.

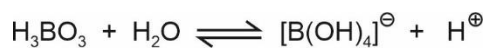

Being a Lewis acid does not explain the reversibility of the reaction.

Hence, Reason is not the correct explanation.

3. Highest spin only magnetic moment is shown by which of the following compound?

MnF₂, MnF₃, MnF₄, MnO₂

- (1) MnF₂ (2) MnF₃
(3) MnF₄ (4) MnO₂

Answer (1)

Sol. Compound	Spin only magnetic moment (μ)
MnF ₂ (d ⁵)	$\sqrt{35}$ B.M.
MnF ₃ (d ⁴)	$\sqrt{24}$ B.M.
MnF ₄ (d ³)	$\sqrt{15}$ B.M.
MnO ₂ (d ³)	$\sqrt{15}$ B.M.

4. Which among the following is a broad spectrum antibiotic drug?

- (1) Ofloxacin (2) Penicillin G
(3) Novestrol (4) Terpeneol

Answer (1)

Sol. Antibiotics which kill or inhibit a wide range of gram positive and gram negative bacteria are said to be broad spectrum antibiotics.

Ofloxacin is an example of broad spectrum antibiotic drug.

5. Which of the following metals is not extracted from sulphide ore?

- (1) Al (2) Fe
(3) Zn (4) Cu

Answer (1)

Sol. Al cannot be extracted from sulphide ore. It is usually extracted from Bauxite ore Leaching of bauxite ore is done followed by electrolytic reduction.

6. Which one of the following is not a benzenoid

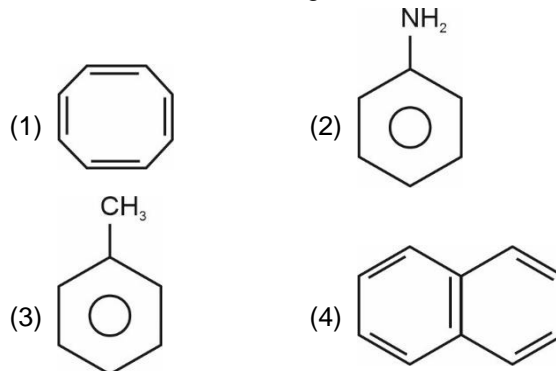

Answer (1)

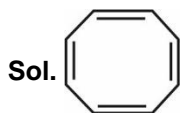

Is not a Benzenoid compound. Benzenoid compound contain benzene rings.

7. Vulcanised Rubber can be prepared from,

- (1) Styrene + Isoprene
- (2) Isoprene + Sulphur
- (3) Neoprene + Sulphur
- (4) Neoprene + Styrene

Answer (2)

Sol. Heating isoprene with sulphur at a temperature range between 373k to 415 K

Probable structure of vulcanised rubber is,

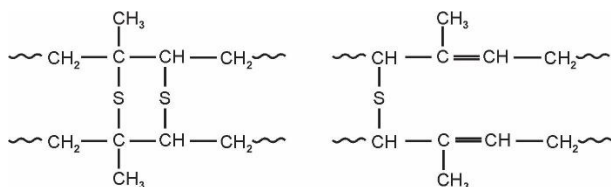

8. Consider the following reaction

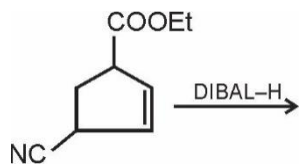

The product formed is

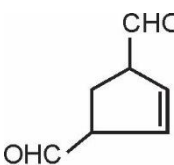
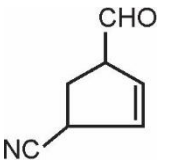
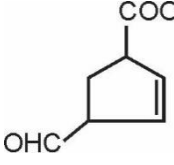
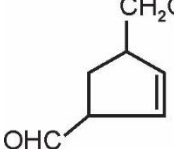
- (1) 
- (2) 
- (3) 
- (4) 

Answer (1)

Sol. DIBAL– H can reduce both esters and –CN group to aldehyde

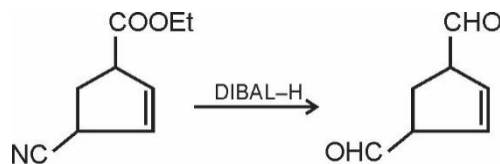

9. If degree of freedom is n, then ratio of C_P and C_V will be

- (1) $\frac{n+2}{n}$
- (2) $\frac{n+1}{2}$
- (3) $\frac{n}{n+2}$
- (4) None of these

Answer (1)

Sol. If n is the degree of freedom of a gas then

$$C_V = \frac{nR}{2}, \text{ and}$$

$$C_P = \frac{nR}{2} + R = \left(\frac{n+2}{2}\right)R$$

$$\frac{C_P}{C_V} = \frac{n+2}{n}$$

10. Which of the following is also known as animal starch

- (1) Glycogen
- (2) Starch
- (3) Sucrose
- (4) None of these

Answer (1)

Sol. Carbohydrates are stored in animal body as glycogen. It is also known as animal starch because its structure is similar to amylopectin and is rather more highly branched.

11. **Assertion:** LiF is sparingly soluble in water.

Reason: Radius of Li^+ is the least among its group members and hence its hydration enthalpy is very less.

- (1) Assertion is correct and Reason is correct explanation of Assertion
- (2) Both Assertion and Reason are correct and Reason is not the correct explanation of Assertion
- (3) Assertion is correct and Reason is incorrect
- (4) Assertion is incorrect and Reason is correct

Answer (3)

Sol. LiF is sparingly soluble due to high lattice energy (due to small size of Li^+ and F^-). Due to small size of Li^+ , it has high hydration energy.

So, Assertion is correct but Reason is a wrong statement.

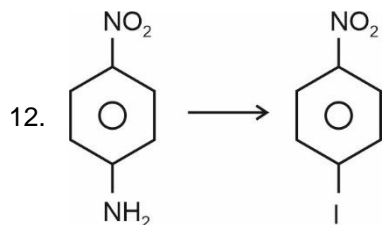

Correct set of reagent for the above conversion is

- (1) NaNO_2/HCl ; KI
- (2) KI ; NaNO_2/HCl
- (3) Fe/HCl ; $\text{NaNO}_2 + \text{HCl}$; KI
- (4) $\text{NaNO}_2 + \text{HCl}$; CH_3I

Answer (1)

Sol.

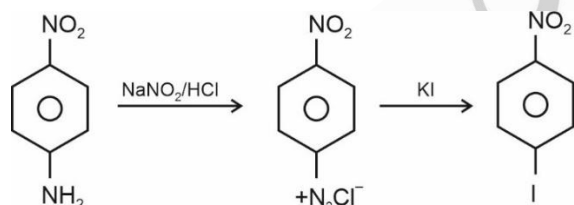

13. Consider a particle of mass m at rest which explodes into two particles of masses $\frac{m'}{3}$ and $\frac{2m'}{3}$

respectively ($m' < m$). What will be the ratio of de-Broglie wavelengths of the particles emitted?

- (1) 1 : 1
- (2) 2 : 1
- (3) 1 : 2
- (4) 4 : 1

Answer (1)

Sol. Applying momentum conservation,

Initial momentum = Final momentum

$$0 = \frac{m'}{3}v_1 + \frac{2m'}{3}v_2$$

$$\frac{m'v_1}{3} = -\frac{2m'v_2}{3}$$

$$v_2 = -\frac{v_1}{2}$$

$$\therefore \frac{\lambda_1}{\lambda_2} = \frac{\frac{h}{m_1v_1}}{\frac{h}{m_2v_2}} = \frac{m_2v_2}{m_1v_1} = 2 \times \frac{1}{2} = 1$$

14. (A) ASSERTION : Phenolphthalein is an organic indicator.

(R) REASON : Phenolphthalein is a weak acid and does not dissociate in a basic solution.

- (1) A and R both are correct and R is correct explanation of A
- (2) A and R both are correct and R is not correct explanation
- (3) A is correct but R is incorrect
- (4) A is incorrect and R is correct

Answer (3)

Sol. Phenolphthalein is an organic indicator used in acid-base titration. So, assertion is true.

It is a weak acid and does not dissociate in an acidic solution. It is colourless in the undissociated form. But it dissociates in a basic solution to give pink coloured conjugate base. So, reason is incorrect.

15. Which of the following complex is diamagnetic in nature

- (1) $\text{K}_3[\text{Fe}(\text{CN})_6]$
- (2) $\text{K}_4[\text{Fe}(\text{CN})_6]$
- (3) $\text{K}_2[\text{Cu}(\text{CN})_4]$
- (4) None

Answer (2)

Sol.

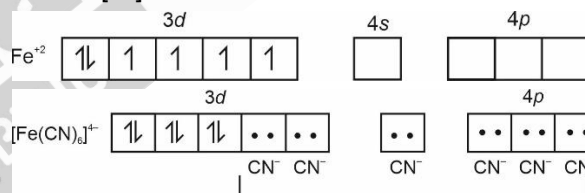
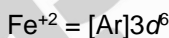
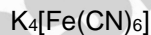

No unpaired electron so diamagnetic in nature.

16. Arrange the following in increasing order of covalent character

- (1) $\text{CaI}_2 < \text{CaBr}_2 < \text{CaCl}_2 < \text{CaF}_2$
- (2) $\text{CaF}_2 < \text{CaCl}_2 < \text{CaBr}_2 < \text{CaI}_2$
- (3) $\text{CaF}_2 < \text{CaCl}_2 < \text{CaI}_2 < \text{CaBr}_2$
- (4) $\text{CaI}_2 < \text{CaCl}_2 < \text{CaBr}_2 < \text{CaI}_2$

Answer (2)

Sol. According to Fajan's rule, for the same metal ion, as the size of anion increases, polarizability of anion increases and hence the covalent character of the given ionic compound increases.

\therefore The correct increasing order of the given compounds is

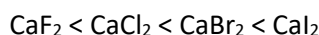

17. When potassium permanganate is reacted with H_2O_2 in acidic medium, then the products formed are,

- (1) Mn^{+4} and H_2O only
- (2) Mn^{+2} and H_2O only
- (3) Mn^{+2} , H_2O and O_2
- (4) Mn^{+4} , H_2O and O_2

Answer (3)

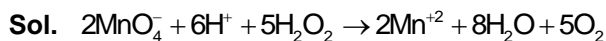

The above reaction shows reducing action of H_2O_2 in acidic medium

Products formed are, Mn^{+2} , H_2O and O_2

18. The ratio of masses of two nuclei of an element is 4 : 3. What will be the ratio of density for such nuclei?

- (1) 3 : 4
- (2) 4 : 3
- (3) 1 : 2
- (4) 1 : 1

Answer (4)

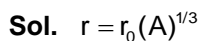

$$\frac{r_1}{r_2} = \left(\frac{A_1}{A_2}\right)^{1/3}$$

$$= \left(\frac{4}{3}\right)^{1/3}$$

$$\frac{r_1^3}{r_2^3} = \frac{4}{3}$$

$$\therefore, \frac{d_1}{d_2} = \frac{\frac{m_1}{v_1}}{\frac{m_2}{v_2}} = \frac{m_1}{m_2} \times \frac{v_2}{v_1}$$

$$= \frac{m_1}{m_2} \times \frac{r_2^3}{r_1^3}$$

$$= \frac{4}{3} \times \frac{3}{4} = 1$$

19.

20.

SECTION - B

Numerical Value Type Questions: This section contains 10 questions. In Section B, attempt any five questions out of 10. The answer to each question is a **NUMERICAL VALUE**. For each question, enter the correct numerical value (in decimal notation, truncated/rounded-off to the second decimal place; e.g. 06.25, 07.00, -00.33, -00.30, 30.27, -27.30) using the mouse and the on-screen virtual numeric keypad in the place designated to enter the answer.

21. Haemoglobin contains 0.34% iron (by mass). What mass of iron (in mg) is present in 33 gm of haemoglobin? (Round off to the nearest integer)

Answer (112)

Sol. Mass of iron present in 100 gm of haemoglobin = 0.34 gm

$$\text{Mass of iron present in 33 gm of haemoglobin} = \frac{0.34 \times 33}{100} = 0.1122 \text{ gm} \approx 112 \text{ mg}$$

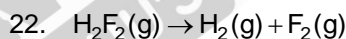

If ΔU for the above reaction is -59.6 kJ/mol at 27°C , then find the value of ΔH (in kJ) at the same temperature ($R = 8.314 \text{ J K}^{-1} \text{ mol}^{-1}$) (Consider magnitude of ΔH only)

Answer (57.11)

Sol. $\Delta H = \Delta U + (\Delta n_g)RT$

As $\Delta n_g = 1$, $\Delta H = \Delta U + 8.314 \times 300$

Magnitude of ΔH (in kJ) = 57.11

23. A is a non-volatile solute. If for 1 molal solution, ΔT_b is 3 K and for 2 molal solution, ΔT_f is 6 K, then find the ratio of K_b and K_f .

Answer (01.00)

Sol. $\Delta T_b = iK_b m$

$$3 = iK_b \times 1 \quad \dots(i)$$

$$\Delta T_f = iK_f m$$

$$6 = iK_f (2) \quad \dots(ii)$$

Dividing (i) and (ii), we get

$$\frac{1}{2} = \left(\frac{K_b}{K_f} \right) \times \frac{1}{2}$$

$$\frac{K_b}{K_f} = 1$$

24. $\text{CH}_3\text{CH}_2\text{MgBr} + \text{CH}_3\text{OH} \rightarrow$ Products

Total number of gaseous product(s) formed in the above reaction is

Answer (01.00)

Sol. $\text{CH}_3\text{CH}_2\text{MgBr} + \text{CH}_3\text{OH} \rightarrow$

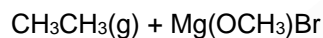

25. A and B form an ideal solution. If mole fraction of A is 0.3 in liquid phase and vapour pressure of pure A and B are 100 torr and 150 torr respectively, then find the mole fraction of A in vapour phase.

Answer (0.22)

Sol. $X_A = 0.3$

$$P_T = P_A^0 X_A + P_B^0 X_B$$

$$= 100(0.3) + 150(0.7)$$

$$= 30 + 105$$

$$= 135 \text{ torr}$$

$$X_A \times P_A^0 = Y_A \times P_T$$

$$(0.3) \times 100 = Y_A(135)$$

$$Y_A = \frac{30}{135} = 0.22$$

26. AB_2 dissociates with $t_{1/2} = 200$ seconds and the half life remains same irrespective of the initial concentration. Find the time taken for 80% completion of the reaction. (in seconds)

[Take $\log 5 = 0.7$ and $\log 2 = 0.3$]

(Round off to nearest integer)

Answer (467)

Sol. As half life remains same irrespective of the initial concentration, the reaction is a first order reaction

$$\left(\frac{0.6909}{200} \right) \times t = 2.303 \log \left(\frac{100}{100 - 80} \right)$$

$$\frac{0.6909}{200} \times t = 2.303 \log 5$$

$$t = \frac{200}{(0.3)} \times 0.7 = 466.67$$

$$\approx 467 \text{ seconds}$$

27. A chemistry teacher tells you to make a solution of pH 8.26. If you have 0.2 M solution of NH_3 in 1 L, how many moles of NH_4Cl will be added to make the required solution.

Given $\text{p}K_b$ for $\text{NH}_3 = 4.74$

Answer (2)

Sol. A mixture of NH_3 and NH_4Cl will form a basic buffer.

pH of the final solution = 8.26

or, pOH of the final solution = 5.74

Let the number of moles of NH_4Cl added to 1 L solution of NH_3 be x.

Using Henderson equation,

$$\text{pOH} = \text{p}K_b + \log \frac{[\text{NH}_4\text{Cl}]}{[\text{NH}_3]}$$

$$5.74 = 4.74 + \log \frac{x}{0.2}$$

On solving,

$$x = 2$$

28.

29.

30.

MATHEMATICS

SECTION - A

Multiple Choice Questions: This section contains 20 multiple choice questions. Each question has 4 choices (1), (2), (3) and (4), out of which **ONLY ONE** is correct.

Choose the correct answer :

1. It $A = \begin{bmatrix} 1 \\ 1 \\ 1 \end{bmatrix}$, $B = \begin{bmatrix} 9^2 & 10^2 & 11^2 \\ 12^2 & -13^2 & 14^2 \\ 15^2 & 16^2 & -17^2 \end{bmatrix}$, then $A'BA$ is

equal to

- (1) [665] (2) [765]
(3) [165] (4) [365]

Answer (1)

Sol. $A = \begin{bmatrix} 1 \\ 1 \\ 1 \end{bmatrix}$, $B = \begin{bmatrix} 9^2 & 10^2 & 11^2 \\ 12^2 & -13^2 & 14^2 \\ 15^2 & 16^2 & -17^2 \end{bmatrix}$

and $A' \equiv [1 \ 1 \ 1]$

$\therefore A'B = [9^2 + 12^2 + 15^2 \quad 10^2 - 13^2 + 16^2 \quad 11^2 + 14^2 - 17^2]$

$A'BA = [9^2 + 12^2 + 15^2 \quad 10^2 - 13^2 + 16^2 \quad 11^2 + 14^2 - 17^2] \begin{bmatrix} 1 \\ 1 \\ 1 \end{bmatrix}$
 $= [9^2 + 12^2 + 15^2 + 10^2 - 13^2 + 16^2 + 11^2 + 14^2 - 17^2]$
 $= [665]$

2. The value of $\int_0^{20\pi} (|\sin x| + |\cos x|) dx$ is equal to

- (1) 20 (2) 40
(3) 60 (4) 80

Answer (4)

Sol. \therefore Period is $\frac{\pi}{2}$

So $\int_0^{20\pi} (|\sin x| + |\cos x|) dx$

$= 40 \int_0^{\frac{\pi}{2}} (\sin x + \cos x) dx$

$= 40(1 + 1)$
 $= 80$

3. The area of region between the curves $y = |x^2 - 1|$ and $y = 1$ is

- (1) $\frac{8}{3}(\sqrt{2} - 1)$ (2) $\frac{8}{3}(\sqrt{2} + 1)$
(3) $\frac{4}{3}(\sqrt{2} - 1)$ (4) $\frac{4}{3}(\sqrt{2} + 1)$

Answer (1)

Sol.

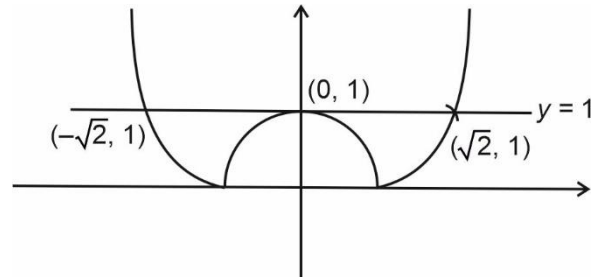

$\therefore \text{Area} = 2 \int_0^{\sqrt{2}} (1 - |x^2 - 1|) dx$

$= 2 \left[\int_0^1 (1 - (1 - x^2)) dx + \int_1^{\sqrt{2}} (2 - x^2) dx \right]$

$= 2 \left[\frac{x^3}{3} \Big|_0^1 + \left(2x - \frac{x^3}{3} \right) \Big|_1^{\sqrt{2}} \right]$

$= 2 \left[\frac{1}{3} + \left(2\sqrt{2} - \frac{2\sqrt{2}}{3} \right) - \left(2 - \frac{1}{3} \right) \right]$

$= 2 \left[\frac{4\sqrt{2} - 4}{3} \right] = \frac{8}{3}(\sqrt{2} - 1)$

4. The interval in which of abscissa of point P on $y = x^2$ lies such that its distance from $(x - 1)^2 + (y + 1)^2 = 1$ is minimum

- (1) $0 < x < \frac{1}{4}$ (2) $\frac{1}{4} < x < \frac{1}{2}$
(3) $\frac{1}{2} < x < \frac{3}{4}$ (4) $\frac{3}{4} < x < 1$

Answer (2)

Sol. Let $P(x, x^2)$

Distance of P from given circle

$l = \sqrt{(x-1)^2 + (x^2+1)^2} - 1$

For least value of l , we need to minimize

$$f(x) = (x - 1)^2 + (x^2 + 1)^2$$

$$\Rightarrow f(x) = 2(x - 1) + 4x(x^2 + 1) = 2[2x^3 + 3x - 1] = 0$$

$$\therefore f' \left(\frac{1}{4} \right) \text{ is -ve and } f' \left(\frac{1}{2} \right) \text{ is +ve}$$

$$\text{So } f(x) = 0 \text{ for some } x \in \left(\frac{1}{4}, \frac{1}{2} \right)$$

5. Equation of common tangent to parabolas $y = x^2$ and $y = -(x - 2)^2$ is

(1) $y = 4x - 4$ (2) $y = -4x + 4$

(3) $y = x - 4$ (4) $y = x + y$

Answer (1)

Sol. Let $y = mx + c$ be the common tangent.

Solving with

$$y = x^2, \text{ we get } x^2 - mx - c = 0$$

$$\Rightarrow D = 0$$

$$\Rightarrow m^2 = -4c \quad \dots(i)$$

Solving with $y = -(x - 2)^2$, we get

$$(x - 2)^2 + mx + c = 0$$

$$\Rightarrow D = 0 \Rightarrow (m - 4)^2 = 4(c + 4)$$

$$\Rightarrow m^2 - 8m = 4c \quad \dots(ii)$$

From (i) and (ii), we get

$$m = 0, c = 0 \text{ or } m = 4, c = -4$$

So, there will be two common tangents.

$$y = 0 \text{ or } y = 4x - 4$$

6. If $x - 1 = 0$ is directrix of hyperbola $kx^2 - y^2 = 6$ then which point lying on hyperbola

(1) $(2\sqrt{5}, 6)$ (2) $(\sqrt{5}, -2)$

(3) $(-\sqrt{5}, 3)$ (4) $(-2\sqrt{5}, 3\sqrt{6})$

Answer (2)

Sol. $\therefore H \equiv \frac{x^2}{\left(\frac{6}{k}\right)} - \frac{y^2}{6} = 1$

$$\text{Directrix} \equiv x = \pm \frac{\sqrt{6}}{\sqrt{k}(\sqrt{1+k})}$$

$$\therefore k\sqrt{1+k} = \sqrt{6}$$

$$\Rightarrow k^2 + k - 6 = 0$$

$$k = 2 \text{ or } -3$$

$$\therefore k = 2 \text{ or } -3$$

$\therefore k = -3$ not possible

$$H \equiv \frac{x^2}{3} - \frac{y^2}{6} = 1$$

$\therefore (\sqrt{5}, -2)$ satisfy the given hyperbola

7. If $|z| - 2 = 0$ and $|z - 1| - |z + 5| = 0$, then

(1) $x^2 + 2y + 4 = 0$

(2) $x^2 - 2y - 4 = 0$

(3) $x + y = 0$

(4) $x^2 - y + 4 = 0$

Answer (1)

Sol. Let $z = x + iy$

$$x^2 + y^2 = 4 \quad \dots(i)$$

$$\text{and } y = -2 \quad \dots(ii)$$

$$\text{So } x = 0$$

Hence only $x^2 + 2y + 4 = 0$ is true.

8. If $\lim_{x \rightarrow 0} \frac{\alpha x - (e^{3x} - 1)}{\alpha x (e^{3x} - 1)} = \beta$, then $\alpha + \beta$ is equal to

(1) $\frac{5}{2}$

(2) $\frac{7}{2}$

(3) 1

(4) 2

Answer (1)

Sol. $\lim_{x \rightarrow 0} \frac{\alpha x + 1 - e^{3x}}{\alpha x \frac{(e^{3x} - 1)}{3x} \cdot 3x} = \beta$

$$\Rightarrow \lim_{x \rightarrow 0} \frac{\alpha x + 1 - e^{3x}}{3\alpha x^2} = \beta$$

Using L' Hospital rule

$$\Rightarrow \lim_{x \rightarrow 0} \frac{\alpha - 3e^{3x}}{6\alpha x} = \beta$$

For indeterminacy to be there

$$\alpha = 3$$

$$\text{And } \beta = \frac{-(e^{3x} - 1)}{6x} = -\frac{1}{2}$$

$$\therefore \alpha + \beta = \frac{5}{2}$$

9. Let $y(x)$ be the solution of differential equation

$$\frac{dy}{dx} + \frac{xy}{x^2 - 1} = \frac{x^4 + 2x}{\sqrt{1 - x^2}}, \quad x \in [-1, 1] \text{ and if } y(0) = 0,$$

then $\int_{-\frac{\sqrt{3}}{2}}^{\frac{\sqrt{3}}{2}} y \, dx$ is equal to

- (1) $\frac{\pi}{3} - \frac{\sqrt{3}}{4}$ (2) $\frac{\pi}{3} + \frac{\sqrt{3}}{2}$
 (3) $\frac{\pi}{3} + \frac{\sqrt{3}}{4}$ (4) $\frac{\pi}{6} - \frac{\sqrt{3}}{2}$

Answer (1)

Sol. I. F. = $e^{\int \frac{-2x}{1-x^2} dx} = \sqrt{1-x^2}$

So, $y\sqrt{1-x^2} = \int (x^4 + 2x) dx + C$

$\Rightarrow y\sqrt{1-x^2} = \frac{x^5}{5} + x^2 + C$ passes through (0, 0)

hence $C = 0$.

Now, $y = \frac{x^2 + \frac{x^5}{5}}{\sqrt{1-x^2}}$

$$\int_{-\frac{\sqrt{3}}{2}}^{\frac{\sqrt{3}}{2}} y \, dx = \int_{-\frac{\sqrt{3}}{2}}^{\frac{\sqrt{3}}{2}} \frac{x^2 + \frac{x^5}{5}}{\sqrt{1-x^2}} dx = 2 \int_0^{\frac{\sqrt{3}}{2}} \frac{x^2}{\sqrt{1-x^2}} dx$$

Let $x = \sin \theta$, $dx = \cos \theta$

$$= 2 \int_0^{\frac{\pi}{3}} \sin^2 \theta \, d\theta = \int_0^{\frac{\pi}{3}} (1 - \cos 2\theta) d\theta = \frac{\pi}{3} - \frac{\sqrt{3}}{4}$$

10. Let roots of $x^2 - 4x - 6 = 0$ are the abscissa and roots of $y^2 + 2y - 7 = 0$ are the ordinates of the end of diameter of the circle $x^2 + y^2 + 2ax + 2by + c = 0$ then $a + b - c$ is equal to

- (1) 10 (2) 11
 (3) 12 (4) -12

Answer (3)

Sol. \because roots of $x^2 - 4x - 6 = 0$ are the abscissa and roots of $y^2 + 2y - 7 = 0$ are ordinate of the end of diameter then equation of circle will be

$$x^2 + y^2 - 4x + 2y - 13 = 0$$

$$\therefore a = -2, b = 1, c = -13$$

$$\therefore a + b - c = -2 + 1 + 13 = 12$$

11. $\sum_{i=0}^n \sum_{\substack{j=0 \\ (i \neq j)}}^n {}^n C_i {}^n C_j$ is equal to

- (1) $2^n C_{n+1}$ (2) $2^n C_n$
 (3) ${}^n C_{n/2}$ (4) C^{2n}

Answer (2)

Sol. $\sum_{i=0}^n \sum_{\substack{j=0 \\ (i \neq j)}}^n {}^n C_i {}^n C_j = {}^n C_0 ({}^n C_1 + {}^n C_2 + \dots + {}^n C_n)$
 $+ {}^n C_1 ({}^n C_0 + {}^n C_2 + \dots + {}^n C_n)$
 $+ {}^n C_2 ({}^n C_0 + {}^n C_1 + {}^n C_3 + \dots + {}^n C_n)$
 $+ \dots + {}^n C_n ({}^n C_0 + {}^n C_1 + \dots + {}^n C_{n-1})$
 $= 2$ [Sum of product taking two at a time of ${}^n C_0, {}^n C_1, {}^n C_2, \dots, {}^n C_n$]
 $= \left[({}^n C_0 + {}^n C_1 + \dots + {}^n C_n)^2 - ({}^n C_0^2 + {}^n C_1^2 + \dots + {}^n C_n^2) \right]$
 $= (2^n)^2 - 2^n C_n$
 $= 2^{2n} - 2^n C_n$

12. Biased coins have probability of getting head is $\frac{2}{3}$ and x is number of heads when six coins are tossed, then the probability $P(x \leq 2)$ is equal to

- (1) $\frac{73}{729}$ (2) $\frac{67}{729}$
 (3) $\frac{23}{729}$ (4) $\frac{73}{243}$

Answer (1)

Sol. Let P is the probability of getting head and $p = \frac{2}{3}$

$$\therefore q = \frac{1}{3}, n = 6$$

$$\therefore P(x \leq 2) = {}^6 C_0 \left(\frac{2}{3}\right)^0 \left(\frac{1}{3}\right)^6 + {}^6 C_1 \left(\frac{2}{3}\right)^1 \left(\frac{1}{3}\right)^5 + {}^6 C_2 \left(\frac{2}{3}\right)^2 \left(\frac{1}{3}\right)^4$$

$$= \frac{1}{3^6} + \frac{12}{3^6} + \frac{60}{3^6}$$

$$= \frac{73}{3^6} = \frac{73}{729}$$

- 13.
- 14.
- 15.
- 16.
- 17.
- 18.
- 19.
- 20.

SECTION - B

Numerical Value Type Questions: This section contains 10 questions. In Section B, attempt any five questions out of 10. The answer to each question is a **NUMERICAL VALUE**. For each question, enter the correct numerical value (in decimal notation, truncated/rounded-off to the second decimal place; e.g. 06.25, 07.00, -00.33, -00.30, 30.27, -27.30) using the mouse and the on-screen virtual numeric keypad in the place designated to enter the answer.

21. The total numbers between 1000 and 3000 divisible by 4 using the digits 1, 2, 3, 4, 5, 6 will be (repetition of digits not allowed)

Answer (30)

Sol. We will solve the question in two cases.

Case I: When first digit is 1. Then last two digits can be 24, 32, 36, 52, 56 and 64. Number of such numbers = $6 \times 3 = 18$

Case II: When first digit is 2.

Then last two digits can be 16, 36, 56 or 64

Number of such numbers = $4 \times 3 = 12$

Total number of numbers = $18 + 12 = 30$

22. If $\sum_{k=1}^{10} \frac{k}{k^4 + k^2 + 1} = \frac{m}{n}$, such that m and n are coprime, then $m + n$ is equal to

Answer (166)

Sol.

$$\sum_{k=1}^{10} \frac{k}{k^4 + k^2 + 1} = \sum_{k=1}^{10} \frac{k}{(k^2 + k + 1)(k^2 - k + 1)}$$

$$= \sum_{k=1}^{10} \frac{1}{2} \left(\frac{1}{k^2 - k + 1} - \frac{1}{k^2 + k + 1} \right)$$

$$= \frac{1}{2} \left[\left(1 - \frac{1}{3} \right) + \left(\frac{1}{3} - \frac{1}{13} \right) + \dots + \left(\frac{1}{91} - \frac{1}{111} \right) \right]$$

$$= \frac{1}{2} \left(1 - \frac{1}{111} \right) = \frac{110}{2 \times 111} = \frac{55}{111}$$

$$\therefore m = 55, n = 111$$

$$\therefore m + n = 166$$

23. The minimum value of the sum of the squares of the roots of the equation $x^2 + (3 - a)x + 2a - 1 = 0$ is

Answer (06)

Sol. Let α, β be the roots of the equation

$$x^2 + (3 - a)x + 1 - 2a = 0$$

$$\text{then } \alpha + \beta = a - 3, \alpha\beta = 1 - 2a$$

$$\text{Now, } \alpha^2 + \beta^2 = (a - 3)^2 - 2(1 - 2a)$$

$$= a^2 - 2a + 7$$

$$= (a - 1)^2 + 6$$

$$\therefore \text{Minimum value of } \alpha^2 + \beta^2 = 6$$

24. Let $A = \{1, 2, 3, 4, 5, 6\}$, $B = \{3, 4, 6, 7, 9\}$ and $C = A \cup B$, then number of elements in cartesian product of $C \times B$ is

Answer (40)

Sol. $A = \{1, 2, 3, 4, 5, 6\}$, $B = \{3, 4, 6, 7, 9\}$

$$\therefore C = A \cup B = \{1, 2, 3, 4, 5, 6, 7, 9\}$$

$$\therefore n(C \times B) = 8 \times 5 = 40$$

25. Let $A = \{1, 2, 3, \dots, 7\}$, and $B = \{3, 6, 7, 9\}$ then find no. of subsets C of A such that $C \cap B \neq \phi$

Answer (112)

Sol. Number of subsets $A = 2^7 = 128$

$$\text{If } C \cap B = \phi$$

Then C must contain only 1, 2, 4 or 5

$$\text{Number of such subsets } C = 2^4 = 16$$

$$\text{No. of required subsets} = 128 - 16$$

$$= 112$$

- 26.
- 27.
- 28.
- 29.
- 30.

