

Telangana State Council Higher Education

Notations :

- 1.Options shown in green color and with ✓ icon are correct.
- 2.Options shown in red color and with ✗ icon are incorrect.

Question Paper Name :	Civil Engineering 2nd Aug 2022 Shift 2
Subject Name :	Civil Engineering
Creation Date :	2022-08-02 17:21:08
Duration :	120
Total Marks :	120
Display Marks:	Yes
Calculator :	None
Magnifying Glass Required? :	No
Ruler Required? :	No
Eraser Required? :	No
Scratch Pad Required? :	No
Rough Sketch/Notepad Required? :	No
Protractor Required? :	No
Show Watermark on Console? :	Yes
Highlighter :	No
Auto Save on Console?	Yes
Change Font Color :	No
Change Background Color :	No
Change Theme :	No
Help Button :	No
Show Reports :	No
Show Progress Bar :	No

Civil Engineering

Group Number :	1
Group Id :	34058041
Group Maximum Duration :	0
Group Minimum Duration :	120
Show Attended Group? :	No
Edit Attended Group? :	No
Break time :	0
Group Marks :	120
Is this Group for Examiner? :	No
Examiner permission :	Cant View
Show Progress Bar? :	No

Mathematics

Section Id :	34058074
Section Number :	1
Section type :	Online
Mandatory or Optional :	Mandatory
Number of Questions :	10
Number of Questions to be attempted :	10
Section Marks :	10
Enable Mark as Answered Mark for Review and Clear Response :	Yes
Maximum Instruction Time :	0
Sub-Section Number :	1
Sub-Section Id :	34058074
Question Shuffling Allowed :	Yes

Question Number : 1 Question Id : 3405804801 Question Type : MCQ Option Shuffling : Yes
Display Question Number : Yes Is Question Mandatory : No Calculator : None Response Time
: N.A Think Time : N.A Minimum Instruction Time : 0

Correct Marks : 1 Wrong Marks : 0

$$\int_1^2 \int_{-1}^1 \int_0^1 (x^3 + y^2 + z) dz dy dx =$$

Options :

34058019201. ✓ $\frac{55}{6}$

34058019202. ✗ $\frac{55}{7}$

34058019203. ✗ $\frac{55}{3}$

34058019204. ✗ 55

Question Number : 2 Question Id : 3405804802 Question Type : MCQ Option Shuffling : Yes
Display Question Number : Yes Is Question Mandatory : No Calculator : None Response Time
: N.A Think Time : N.A Minimum Instruction Time : 0

Correct Marks : 1 Wrong Marks : 0

The number of critical points of $f(x, y) = x^4 - 16xy + y^4$ is

Options :

34058019205. ✗ 0

34058019206. ✗ 1

34058019207. ✗ 2

34058019208. ✓ 3

Question Number : 3 Question Id : 3405804803 Question Type : MCQ Option Shuffling : Yes
Display Question Number : Yes Is Question Mandatory : No Calculator : None Response Time
: N.A Think Time : N.A Minimum Instruction Time : 0
Correct Marks : 1 Wrong Marks : 0

The product of eigen values of $\begin{bmatrix} 1 & -2 & 3 \\ 2 & -1 & 3 \\ 3 & -1 & 2 \end{bmatrix}$ is

Options :

34058019209. ✗ 4

34058019210. ✗ 5

34058019211. ✓ 6

34058019212. ✗ 7

Question Number : 4 Question Id : 3405804804 Question Type : MCQ Option Shuffling : Yes
Display Question Number : Yes Is Question Mandatory : No Calculator : None Response Time
: N.A Think Time : N.A Minimum Instruction Time : 0
Correct Marks : 1 Wrong Marks : 0

The rank of the matrix $\begin{bmatrix} 0 & 4 & -2 & 1 \\ 1 & -2 & 3 & -1 \\ 1 & 2 & -1 & -1 \\ -1 & 2 & -1 & 2 \end{bmatrix}$ is

Options :

34058019213. ✖ 1

34058019214. ✖ 2

34058019215. ✔ 3

34058019216. ✖ 4

Question Number : 5 Question Id : 3405804805 Question Type : MCQ Option Shuffling : Yes Display Question Number : Yes Is Question Mandatory : No Calculator : None Response Time : N.A Think Time : N.A Minimum Instruction Time : 0

Correct Marks : 1 Wrong Marks : 0

If the solution of $y''(x) + y(x) = 0$, $y(0) = -1$, $y'(0) = 2$ is $y = a \cos x + b \sin x$, then $a^2 + b^2 =$

Options :

34058019217. ✖ 4

34058019218. ✔ 5

34058019219. ✖ 6

34058019220. ✖ 7

Question Number : 6 Question Id : 3405804806 Question Type : MCQ Option Shuffling : Yes Display Question Number : Yes Is Question Mandatory : No Calculator : None Response Time : N.A Think Time : N.A Minimum Instruction Time : 0

Correct Marks : 1 Wrong Marks : 0

The particular integral of $y'' - 4y = xe^x$ is $y_p = k(2e^x + 3xe^x)$, where $k =$

Options :

34058019221. ✓ $-\frac{1}{9}$

34058019222. ✗ $\frac{1}{9}$

34058019223. ✗ $\frac{1}{3}$

34058019224. ✗ $-\frac{1}{3}$

Question Number : 7 Question Id : 3405804807 Question Type : MCQ Option Shuffling : Yes Display Question Number : Yes Is Question Mandatory : No Calculator : None Response Time : N.A Think Time : N.A Minimum Instruction Time : 0 Correct Marks : 1 Wrong Marks : 0

The residue of $f(z) = \frac{1}{\sin z \cos z}$ at $z = -\frac{\pi}{2}$ is

Options :

34058019225. ✗ 1

34058019226. ✓ -1

34058019227. ✗ 0

34058019228. ✗ 2

Question Number : 8 Question Id : 3405804808 Question Type : MCQ Option Shuffling : Yes Display Question Number : Yes Is Question Mandatory : No Calculator : None Response Time

: N.A Think Time : N.A Minimum Instruction Time : 0

Correct Marks : 1 Wrong Marks : 0

A bag contains 3 white, 5 red and 6 black balls. If three balls are drawn at random, then the probability that the draw results in no red ball is

Options :

34058019229. ✖ $\frac{9}{14}$

34058019230. ✖ $\frac{{}^{11}C_3}{{}^{14}C_3}$

34058019231. ✖ $\frac{{}^8C_3}{{}^{14}C_3}$

34058019232. ✔ $\frac{{}^9C_3}{{}^{14}C_3}$

Question Number : 9 Question Id : 3405804809 Question Type : MCQ Option Shuffling : Yes
Display Question Number : Yes Is Question Mandatory : No Calculator : None Response Time
: N.A Think Time : N.A Minimum Instruction Time : 0

Correct Marks : 1 Wrong Marks : 0

If the random variable X has the following probability distribution and has the mean $\frac{10}{3}$ then the value of k is

x	1	k	3	4
P(X = x)	c	4c	9c	16c

Options :

34058019233. ✖ 1

34058019234. ✓ 2

34058019235. ✗ 3

34058019236. ✗ 4

**Question Number : 10 Question Id : 3405804810 Question Type : MCQ Option Shuffling : Yes
Display Question Number : Yes Is Question Mandatory : No Calculator : None Response Time
: N.A Think Time : N.A Minimum Instruction Time : 0
Correct Marks : 1 Wrong Marks : 0**

$$\int_{|z|=1} \operatorname{cosec}^2 z \, dz =$$

Options :

34058019237. ✗ πi

34058019238. ✗ $2\pi i$

34058019239. ✗ $-\pi i$

34058019240. ✓ 0

Civil Engineering

Section Id :	34058075
Section Number :	2
Section type :	Online
Mandatory or Optional :	Mandatory

Number of Questions :	110
Number of Questions to be attempted :	110
Section Marks :	110
Enable Mark as Answered Mark for Review and Clear Response :	Yes
Maximum Instruction Time :	0
Sub-Section Number :	1
Sub-Section Id :	34058075
Question Shuffling Allowed :	Yes

Question Number : 11 Question Id : 3405804811 Question Type : MCQ Option Shuffling : Yes
Display Question Number : Yes Is Question Mandatory : No Calculator : None Response Time : N.A Think Time : N.A Minimum Instruction Time : 0
Correct Marks : 1 Wrong Marks : 0

As per IS 456:2000, stresses in concrete and steel can be increased upto _____ when the structure is subjected to wind loading and seismic forces

Options :

34058019241. ✘ 25%

34058019242. ✘ 50 %

34058019243. ✔ 33.33%

34058019244. ✘ 10 %

Question Number : 12 Question Id : 3405804812 Question Type : MCQ Option Shuffling : Yes
Display Question Number : Yes Is Question Mandatory : No Calculator : None Response Time : N.A Think Time : N.A Minimum Instruction Time : 0
Correct Marks : 1 Wrong Marks : 0

A clay deposit of 6 m thickness has a thin sand layer at a distance of 2 m above the bottom. Taking c_v of clay as $1.2 \times 10^{-4} \text{ cm}^2/\text{s}$, the ratio of degrees of consolidation of the lower and upper layers of this clay bed considering the drainage on both sides is _____

Options :

34058019245. ✓ 4.0

34058019246. ✗ 2.2

34058019247. ✗ 3.8

34058019248. ✗ 0.5

Question Number : 13 Question Id : 3405804813 Question Type : MCQ Option Shuffling : Yes Display Question Number : Yes Is Question Mandatory : No Calculator : None Response Time : N.A Think Time : N.A Minimum Instruction Time : 0

Correct Marks : 1 Wrong Marks : 0

A flow net drawn for an earth dam foundation consists of 10 flow channels and 16 potential drops. The dam is under steady seepage condition with 10 m of water head in the reservoir. The uplift pressure at 14th potential drop is

Options :

34058019249. ✓ 12.5 kPa

34058019250. ✗ 87.5 kPa

34058019251. ✗ 7.14 kPa

34058019252. ✗ 6.25 kPa

Question Number : 14 Question Id : 3405804814 Question Type : MCQ Option Shuffling : Yes
Display Question Number : Yes Is Question Mandatory : No Calculator : None Response Time
: N.A Think Time : N.A Minimum Instruction Time : 0

Correct Marks : 1 Wrong Marks : 0

What is the departure of survey line measuring 30 m making a bearing angle of 210°

Options :

34058019253. ✘ 15 m

34058019254. ✘ $15\sqrt{3}$ m

34058019255. ✔ -15 m

34058019256. ✘ $-15\sqrt{3}$ m

Question Number : 15 Question Id : 3405804815 Question Type : MCQ Option Shuffling : Yes
Display Question Number : Yes Is Question Mandatory : No Calculator : None Response Time
: N.A Think Time : N.A Minimum Instruction Time : 0

Correct Marks : 1 Wrong Marks : 0

Reduced level of the building floor is 120.200 m. Leveling staff reading on floor is 1.210 m. When staff is held inverted with bottom touching the ceiling of the building is 4.890 m. Find the height of the ceiling from the floor

Options :

34058019257. ✔ 6.100 m

34058019258. ✘ 3.680 m

34058019259. ✘ 3.980 m

34058019260. ✖ 5.090 m

Question Number : 16 Question Id : 3405804816 Question Type : MCQ Option Shuffling : Yes Display Question Number : Yes Is Question Mandatory : No Calculator : None Response Time : N.A Think Time : N.A Minimum Instruction Time : 0

Correct Marks : 1 Wrong Marks : 0

As a common guideline of route continuity the design speed differential between the main lines and the interchange ramp should be smaller than _____ of the main line design speed

Options :

34058019261. ✔ 0.3 times

34058019262. ✖ 0.1 times

34058019263. ✖ 0.01 times

34058019264. ✖ 1.0 time

Question Number : 17 Question Id : 3405804817 Question Type : MCQ Option Shuffling : Yes Display Question Number : Yes Is Question Mandatory : No Calculator : None Response Time : N.A Think Time : N.A Minimum Instruction Time : 0

Correct Marks : 1 Wrong Marks : 0

The number of rain gauge stations in a drainage basin is 9. The coefficient of variation of the average annual rainfall of these stations is 0.3. The percentage error in estimation of the average rainfall in the existing network is

Options :

34058019265. ✖ 5

34058019266. ✖ 3.33

34058019267. ✖ 3

34058019268. ✔ 10

Question Number : 18 Question Id : 3405804818 Question Type : MCQ Option Shuffling : Yes Display Question Number : Yes Is Question Mandatory : No Calculator : None Response Time : N.A Think Time : N.A Minimum Instruction Time : 0

Correct Marks : 1 Wrong Marks : 0

A 6-hour storm had 6 cm of rainfall and the resulting runoff was 3 cm. Assuming constant rainfall intensity and if the ϕ -index remains at the same value, the runoff due to 12 cm of rainfall in 9 h in the catchment is

Options :

34058019269. ✖ 9 cm

34058019270. ✖ 4.5 cm

34058019271. ✖ 6 cm

34058019272. ✔ 7.5 cm

Question Number : 19 Question Id : 3405804819 Question Type : MCQ Option Shuffling : Yes Display Question Number : Yes Is Question Mandatory : No Calculator : None Response Time : N.A Think Time : N.A Minimum Instruction Time : 0

Correct Marks : 1 Wrong Marks : 0

A circular rod of 10 mm diameter is tested for tension and it was observed that, when tension was 11 kN, the total extension on a 300 mm length was 0.2 mm. The Young's modulus (kN/mm^2) is

Options :

34058019273. ✓ 210

34058019274. ✘ 200

34058019275. ✘ 140.6

34058019276. ✘ 225.4

Question Number : 20 Question Id : 3405804820 Question Type : MCQ Option Shuffling : Yes Display Question Number : Yes Is Question Mandatory : No Calculator : None Response Time : N.A Think Time : N.A Minimum Instruction Time : 0

Correct Marks : 1 Wrong Marks : 0

Two bars of same size and length but of different materials are subjected to same tensile force. If the bars have their axial elongation in the ratio of 4:6, then the ratio of modulus of elasticity of the two materials would be

Options :

34058019277. ✘ 2:3

34058019278. ✘ 3:6

34058019279. ✘ 3:4

34058019280. ✓ 6:4

Question Number : 21 Question Id : 3405804821 Question Type : MCQ Option Shuffling : Yes Display Question Number : Yes Is Question Mandatory : No Calculator : None Response Time : N.A Think Time : N.A Minimum Instruction Time : 0

Correct Marks : 1 Wrong Marks : 0

A body is subjected to two normal strains of magnitudes 0.003 and 0.002 along x and y directions respectively. The shearing strain on a plane inclined at 30° with strain in x direction is given by

Options :

34058019281. ✘ 0.30×10^{-3}

34058019282. ✔ 0.5×10^{-3}

34058019283. ✘ 0.4×10^{-3}

34058019284. ✘ 0.10×10^{-3}

Question Number : 22 Question Id : 3405804822 Question Type : MCQ Option Shuffling : Yes Display Question Number : Yes Is Question Mandatory : No Calculator : None Response Time : N.A Think Time : N.A Minimum Instruction Time : 0

Correct Marks : 1 Wrong Marks : 0

A steel wire of 20 mm diameter is bent into a circular shape of 10 m radius. If the modulus of elasticity is 2×10^5 N/mm², the maximum stress (N/mm²) included in the wire is

Options :

34058019285. ✘ 100

34058019286. ✘ 180

34058019287. ✔ 200

34058019288. ✘ 210

Question Number : 23 Question Id : 3405804823 Question Type : MCQ Option Shuffling : Yes
Display Question Number : Yes Is Question Mandatory : No Calculator : None Response Time
: N.A Think Time : N.A Minimum Instruction Time : 0

Correct Marks : 1 Wrong Marks : 0

A submerged soil bed is having dry unit weight of 16 kN/m^3 and water content = 26%. The shear strength parameters as obtained from laboratory testing are $c' = 45 \text{ kPa}$ and $\phi' = 28^\circ$. The shear strength of this soil on a plane at 12 m depth will be

Options :

34058019289. ✘ 45 kPa

34058019290. ✘ 50.4 kPa

34058019291. ✔ 109.82 kPa

34058019292. ✘ 178.63 kPa

Question Number : 24 Question Id : 3405804824 Question Type : MCQ Option Shuffling : Yes
Display Question Number : Yes Is Question Mandatory : No Calculator : None Response Time
: N.A Think Time : N.A Minimum Instruction Time : 0

Correct Marks : 1 Wrong Marks : 0

A saturated clay bed below an embankment has undergone a settlement of 8 cm in 2 years. If the estimated total settlement of clay bed is 18 cm, the time factor at the end of 2 years' time period is

Options :

34058019293. ✘ 0.10

34058019294. ✘ 0.077

34058019295. ✘ 0.038

34058019296. ✓ 0.155

Question Number : 25 Question Id : 3405804825 Question Type : MCQ Option Shuffling : Yes Display Question Number : Yes Is Question Mandatory : No Calculator : None Response Time : N.A Think Time : N.A Minimum Instruction Time : 0

Correct Marks : 1 Wrong Marks : 0

An Aerial camera having 150 mm focal length lens is used to take vertical photograph from the flying height of 3000 m above mean sea level. Terrain is flat and located at an elevation of 500 m. Calculate the scale of the photograph

Options :

34058019297. ✘ 1: 10,000

34058019298. ✓ 1: 20,000

34058019299. ✘ 1: 30,000

34058019300. ✘ 1:15,000

Question Number : 26 Question Id : 3405804826 Question Type : MCQ Option Shuffling : Yes Display Question Number : Yes Is Question Mandatory : No Calculator : None Response Time : N.A Think Time : N.A Minimum Instruction Time : 0

Correct Marks : 1 Wrong Marks : 0

In which wavelength length region of electromagnetic spectrum vegetation has maximum spectral reflectance.

Options :

34058019301. ✘ Green

34058019302. ✘ Thermal

34058019303. ✘ Microwave

34058019304. ✔ Near Infra-Red

Question Number : 27 Question Id : 3405804827 Question Type : MCQ Option Shuffling : Yes Display Question Number : Yes Is Question Mandatory : No Calculator : None Response Time : N.A Think Time : N.A Minimum Instruction Time : 0

Correct Marks : 1 Wrong Marks : 0

In a traffic flow study conducted for an hour, it was observed that the hourly flow is 2625 vehicles and maximum 5 minute volume observed was 284 vehicles. The peak hour factor is

Options :

34058019305. ✘ 0.90

34058019306. ✘ 0.83

34058019307. ✔ 0.77

34058019308. ✘ 0.43

Question Number : 28 Question Id : 3405804828 Question Type : MCQ Option Shuffling : Yes Display Question Number : Yes Is Question Mandatory : No Calculator : None Response Time : N.A Think Time : N.A Minimum Instruction Time : 0

Correct Marks : 1 Wrong Marks : 0

The length of vehicle is 5 m and the length of loop detector zone is 2.5 m. The time occupancy in the loop is 0.5 sec. The spot speed of the vehicle in m/s is

Options :

34058019309. ✓ 15

34058019310. ✘ 10

34058019311. ✘ 8.4

34058019312. ✘ 05

Question Number : 29 Question Id : 3405804829 Question Type : MCQ Option Shuffling : Yes Display Question Number : Yes Is Question Mandatory : No Calculator : None Response Time : N.A Think Time : N.A Minimum Instruction Time : 0

Correct Marks : 1 Wrong Marks : 0

Based on the analysis of annual maximum flows at a location, the location and scale parameters of Gumbel distribution are estimates as $173 \text{ m}^3/\text{s}$ and $47 \text{ m}^3/\text{s}$ respectively. The return period of a flood of magnitude $220 \text{ m}^3/\text{s}$ is

Options :

34058019313. ✘ 5 years

34058019314. ✘ 2.5 years

34058019315. ✘ 1.44 years

34058019316. ✓ 3.25 years

Question Number : 30 Question Id : 3405804830 Question Type : MCQ Option Shuffling : Yes Display Question Number : Yes Is Question Mandatory : No Calculator : None Response Time : N.A Think Time : N.A Minimum Instruction Time : 0

Correct Marks : 1 Wrong Marks : 0

The flow duration curve is a graph between

Options :

34058019317. ✘ The cumulative discharge and time
34058019318. ✘ The discharge and the percentage time such discharge is not exceeded
34058019319. ✘ Discharge in the stream and time
34058019320. ✔ The discharge and the percentage time such discharge is equalled or exceeded

Question Number : 31 Question Id : 3405804831 Question Type : MCQ Option Shuffling : Yes
Display Question Number : Yes Is Question Mandatory : No Calculator : None Response Time : N.A Think Time : N.A Minimum Instruction Time : 0

Correct Marks : 1 Wrong Marks : 0

A simply supported beam of span L meters carries a uniformly distributed load of (W/L) kN/m over the entire span and a concentrated load of W kN at the middle of the span. If the flexural rigidity of the beam is EI , the total deflection of the beam at midpoint due to all loadings is

Options :

34058019321. ✘ $\frac{5WL^3}{384EI}$

34058019322. ✘ $\frac{9WL^3}{384EI}$

34058019323. ✔ $\frac{13WL^3}{384EI}$

34058019324. ✘

$$\frac{18WL^3}{384EI}$$

Question Number : 32 Question Id : 3405804832 Question Type : MCQ Option Shuffling : Yes
Display Question Number : Yes Is Question Mandatory : No Calculator : None Response Time
: N.A Think Time : N.A Minimum Instruction Time : 0

Correct Marks : 1 Wrong Marks : 0

The deflection of the free end of a cantilever beam subjected to a couple M at its free end and having uniform flexural rigidity EI throughout its length L is equal to

Options :

34058019325. ✓ $\frac{ML^2}{2EI}$

34058019326. ✗ $\frac{ML^3}{3EI}$

34058019327. ✗ $\frac{ML^2}{6EI}$

34058019328. ✗ $\frac{ML^2}{8EI}$

Question Number : 33 Question Id : 3405804833 Question Type : MCQ Option Shuffling : Yes
Display Question Number : Yes Is Question Mandatory : No Calculator : None Response Time
: N.A Think Time : N.A Minimum Instruction Time : 0

Correct Marks : 1 Wrong Marks : 0

A water main 160 cm diameter contains water at a pressure head of 200 m. Take unit weight of water to be 1000 kg/m^3 . The thickness of metal shell required for the water main, given that the maximum permissible stress in the metal is 400 kg/cm^2 , will be

Options :

34058019329. ✖ 1 cm

34058019330. ✖ 2 cm

34058019331. ✖ 3 cm

34058019332. ✔ 4 cm

Question Number : 34 Question Id : 3405804834 Question Type : MCQ Option Shuffling : Yes Display Question Number : Yes Is Question Mandatory : No Calculator : None Response Time : N.A Think Time : N.A Minimum Instruction Time : 0

Correct Marks : 1 Wrong Marks : 0

A 4.5 m thick clay bed is between the free draining sand layers and it has $C_v = 1.16 \times 10^{-3} \text{ cm}^2/\text{sec}$. The time required for 80% of total settlement to take place is

Options :

34058019333. ✖ 1474 days

34058019334. ✔ 2474 days

34058019335. ✖ 3474 days

34058019336. ✖ 474 days

Question Number : 35 Question Id : 3405804835 Question Type : MCQ Option Shuffling : Yes
Display Question Number : Yes Is Question Mandatory : No Calculator : None Response Time
: N.A Think Time : N.A Minimum Instruction Time : 0

Correct Marks : 1 Wrong Marks : 0

In triaxial test on a soil sample with $\sigma_3 = 150$ kPa, it failed at $\sigma_1 = 350$ kPa.
For the same soil sample, the σ_1 would be ___ under $\sigma_3 = 200$ kPa for $\phi = 0^\circ$

Options :

34058019337. ✘ 350 kPa

34058019338. ✔ 400 kPa

34058019339. ✘ 500 kPa

34058019340. ✘ 550 kPa

Question Number : 36 Question Id : 3405804836 Question Type : MCQ Option Shuffling : Yes
Display Question Number : Yes Is Question Mandatory : No Calculator : None Response Time
: N.A Think Time : N.A Minimum Instruction Time : 0

Correct Marks : 1 Wrong Marks : 0

Drones comes under what type of remote-sensing platform

Options :

34058019341. ✘ Terrestrial

34058019342. ✔ Aerial

34058019343. ✘ Space based

34058019344. ✘ Global

Question Number : 37 Question Id : 3405804837 Question Type : MCQ Option Shuffling : Yes
Display Question Number : Yes Is Question Mandatory : No Calculator : None Response Time
: N.A Think Time : N.A Minimum Instruction Time : 0

Correct Marks : 1 Wrong Marks : 0

In GPS method of measuring locations, minimum number of satellites required to establish the ground position are _____

Options :

34058019345. ✖ 5

34058019346. ✖ 2

34058019347. ✖ 3

34058019348. ✔ 4

Question Number : 38 Question Id : 3405804838 Question Type : MCQ Option Shuffling : Yes
Display Question Number : Yes Is Question Mandatory : No Calculator : None Response Time
: N.A Think Time : N.A Minimum Instruction Time : 0

Correct Marks : 1 Wrong Marks : 0

What is the projection and datum of SOI open series maps

Options :

34058019349. ✔ UTM, WGS 84

34058019350. ✖ TM, Everest India-Nepal

34058019351. ✖ Azimuthal, Everest India

34058019352. ✖ Orthographic, Ellipsoid

Question Number : 39 Question Id : 3405804839 Question Type : MCQ Option Shuffling : Yes Display Question Number : Yes Is Question Mandatory : No Calculator : None Response Time : N.A Think Time : N.A Minimum Instruction Time : 0

Correct Marks : 1 Wrong Marks : 0

On a particular day along a section of a highway, vehicles were observed be maintaining an average spacing of 16 meters and average time headway of 3 seconds. The average traffic stream speed in km/h is _____

Options :

34058019353. ✖ 62.5

34058019354. ✖ 48.0

34058019355. ✔ 19.2

34058019356. ✖ 15.0

Question Number : 40 Question Id : 3405804840 Question Type : MCQ Option Shuffling : Yes Display Question Number : Yes Is Question Mandatory : No Calculator : None Response Time : N.A Think Time : N.A Minimum Instruction Time : 0

Correct Marks : 1 Wrong Marks : 0

In the flash point test conducted using Pensky Marten's apparatus, the molten bitumen is stirred at a rate of _____ rpm

Options :

34058019357. ✖ 30

34058019358. ✖ 33

34058019359. ✔ 60

34058019360. ✖ 163

Question Number : 41 Question Id : 3405804841 Question Type : MCQ Option Shuffling : Yes
Display Question Number : Yes Is Question Mandatory : No Calculator : None Response Time
: N.A Think Time : N.A Minimum Instruction Time : 0

Correct Marks : 1 Wrong Marks : 0

Safe yield is defined as

Options :

34058019361. ✖ The change in the water table when a well is pumped at a constant rate

34058019362. ✔ The rate at which water can be pumped from an aquifer without lowering
the water table

34058019363. ✖ The product of the specific yield and the change in the elevation of the
water table

34058019364. ✖ The volume of water that can be safely harvested from an aquifer

Question Number : 42 Question Id : 3405804842 Question Type : MCQ Option Shuffling : Yes
Display Question Number : Yes Is Question Mandatory : No Calculator : None Response Time
: N.A Think Time : N.A Minimum Instruction Time : 0

Correct Marks : 1 Wrong Marks : 0

The Ca^{2+} concentration and Mg^{2+} concentration of a water sample are 160
mg/l and 40 mg/l as their ions respectively. The total hardness of this water
sample in terms of CaCO_3 in mg/l is equal to _____

Options :

34058019365. ✖ 120

34058019366. ✖ 200

34058019367. ✖ 267

34058019368. ✔ 567

Question Number : 43 Question Id : 3405804843 Question Type : MCQ Option Shuffling : Yes Display Question Number : Yes Is Question Mandatory : No Calculator : None Response Time : N.A Think Time : N.A Minimum Instruction Time : 0

Correct Marks : 1 Wrong Marks : 0

The Double mass curve technique is adopted to

Options :

34058019369. ✔ Check the consistency of the rain gauge records

34058019370. ✖ To find the average rainfall over a period

34058019371. ✖ To find the number of rain gauge required in any area

34058019372. ✖ To estimate the missing rainfall data

Question Number : 44 Question Id : 3405804844 Question Type : MCQ Option Shuffling : Yes Display Question Number : Yes Is Question Mandatory : No Calculator : None Response Time : N.A Think Time : N.A Minimum Instruction Time : 0

Correct Marks : 1 Wrong Marks : 0

The surface velocity at any vertical section of a stream is

Options :

34058019373. ✖ Not of any use in streamflow measurement

34058019374. ✘ Smaller than the mean velocity in that vertical section

34058019375. ✔ Larger than the mean velocity in that vertical section

34058019376. ✘ Equal to the velocity in that velocity at 0.6 times the depth

Question Number : 45 Question Id : 3405804845 Question Type : MCQ Option Shuffling : Yes Display Question Number : Yes Is Question Mandatory : No Calculator : None Response Time : N.A Think Time : N.A Minimum Instruction Time : 0

Correct Marks : 1 Wrong Marks : 0

A short hollow column of external diameter D and internal diameter d is subjected to a load W with an eccentricity e , causing zero stresses at the extreme fibre. The value of eccentricity 'e' must be

Options :

34058019377. ✘ $\frac{D^2 + d^2}{8\pi D}$

34058019378. ✔ $\frac{D^2 + d^2}{8D}$

34058019379. ✘ $\frac{D^2 - d^2}{8D}$

34058019380. ✘ $\frac{D^2 - d^2}{8\pi D}$

Question Number : 46 Question Id : 3405804846 Question Type : MCQ Option Shuffling : Yes Display Question Number : Yes Is Question Mandatory : No Calculator : None Response Time : N.A Think Time : N.A Minimum Instruction Time : 0

Correct Marks : 1 Wrong Marks : 0

The ultimate moment of resistance (in kNm) of rectangular beam 350 x 550 mm effective depth which is casted with M30 grade concrete, consists of 4 bars of 25 mm diameter of Fe250 grade is

Options :

34058019381. ✖ 187.4

34058019382. ✖ 196.8

34058019383. ✔ 214.9

34058019384. ✖ 236.6

Question Number : 47 Question Id : 3405804847 Question Type : MCQ Option Shuffling : Yes Display Question Number : Yes Is Question Mandatory : No Calculator : None Response Time : N.A Think Time : N.A Minimum Instruction Time : 0

Correct Marks : 1 Wrong Marks : 0

The bond strength for M20 concrete as per IS 456:2000 is 1.2 N/mm^2 . For tensile reinforcing steel of grade Fe 415, the development length in terms of bar diameter ' ϕ ' is

Options :

34058019385. ✔ 47ϕ

34058019386. ✖ 54ϕ

34058019387. ✖ 58ϕ

34058019388. ✖ 51ϕ

Question Number : 48 Question Id : 3405804848 Question Type : MCQ Option Shuffling : Yes Display Question Number : Yes Is Question Mandatory : No Calculator : None Response Time : N.A Think Time : N.A Minimum Instruction Time : 0

Correct Marks : 1 Wrong Marks : 0

The equivalent shear force for an RC beam 300 x 400 mm effective depth, subjected to a bending moment of 200 kNm, shear force of 20 kN and a torque of 9 kNm is

Options :

34058019389. ✓ 68 kN

34058019390. ✗ 50 kN

34058019391. ✗ 79 kN

34058019392. ✗ 55 kN

Question Number : 49 Question Id : 3405804849 Question Type : MCQ Option Shuffling : Yes Display Question Number : Yes Is Question Mandatory : No Calculator : None Response Time : N.A Think Time : N.A Minimum Instruction Time : 0

Correct Marks : 1 Wrong Marks : 0

A borrow soil to be used in an embankment construction has: gravel = 28%, sand = 52%, fine = 20%, Liquid limit = 34%, Plastic limit = 14%, OMC = 10.5% and MDD = 1.86 g/cc. If the specific gravity of soil solids is 2.66, the theoretical maximum dry density of this soil at OMC is

Options :

34058019393. ✗ 2.66 g/cc

34058019394. ✗ 1.97 g.cc

34058019395. ✗ 1.86 g/cc

34058019396. ✓ 2.08 g/cc

Question Number : 50 Question Id : 3405804850 Question Type : MCQ Option Shuffling : Yes Display Question Number : Yes Is Question Mandatory : No Calculator : None Response Time : N.A Think Time : N.A Minimum Instruction Time : 0

Correct Marks : 1 Wrong Marks : 0

A soil is compacted to a bulk density of 2 g/cc at a water content of 12%. Taking the specific gravity of soil solids as 2.65, the air content in the soil is about

Options :

34058019397. ✗ 65%

34058019398. ✗ 88%

34058019399. ✓ 34%

34058019400. ✗ 12%

Question Number : 51 Question Id : 3405804851 Question Type : MCQ Option Shuffling : Yes Display Question Number : Yes Is Question Mandatory : No Calculator : None Response Time : N.A Think Time : N.A Minimum Instruction Time : 0

Correct Marks : 1 Wrong Marks : 0

Which one of following spatial problem can be better addressed with raster model

Options :

34058019401. ✗ Water Distribution Network

34058019402. ✗ Cadastral maps for the villages

34058019403. ✓ Hydrological modeling in a watershed

34058019404. ✘ Road Network

Question Number : 52 Question Id : 3405804852 Question Type : MCQ Option Shuffling : Yes
Display Question Number : Yes Is Question Mandatory : No Calculator : None Response Time
: N.A Think Time : N.A Minimum Instruction Time : 0

Correct Marks : 1 Wrong Marks : 0

Calculate the Reduced Level of the top of the electric pole which is at distance of 300 m from the levelling instrument station. From the instrument station Back Sight of the levelling staff is 2.500 m which is kept at Bench Mark point whose reduced level is 100 m. The vertical angle made by the top of the electric pole is 45° from the instrument station

Options :

34058019405. ✘ 102.500 m

34058019406. ✘ 302.500 m

34058019407. ✘ 202.500 m

34058019408. ✓ 402.5 m

Question Number : 53 Question Id : 3405804853 Question Type : MCQ Option Shuffling : Yes
Display Question Number : Yes Is Question Mandatory : No Calculator : None Response Time
: N.A Think Time : N.A Minimum Instruction Time : 0

Correct Marks : 1 Wrong Marks : 0

The hourly flow rate on a highway section is 90 vehicles/hour and the flow follows a Poisson distribution. The number of minutes in an hour, there are no vehicles arriving is _____

Options :

34058019409. ✓ 13.38

34058019410. ✗ 1.5

34058019411. ✗ 8.38

34058019412. ✗ 22.3

Question Number : 54 Question Id : 3405804854 Question Type : MCQ Option Shuffling : Yes Display Question Number : Yes Is Question Mandatory : No Calculator : None Response Time : N.A Think Time : N.A Minimum Instruction Time : 0

Correct Marks : 1 Wrong Marks : 0

The spot speed values in km/h observed on a highway section are 25, 32, 28, 42, 43.5, 39.6, 43, 26, 20, and 18.5 at an average density of 60 vehicles/km. The average flow of the traffic stream in vehicles/hour is _____

Options :

34058019413. ✗ 1905

34058019414. ✗ 3645

34058019415. ✓ 1740

34058019416. ✗ 1860

Question Number : 55 Question Id : 3405804855 Question Type : MCQ Option Shuffling : Yes
Display Question Number : Yes Is Question Mandatory : No Calculator : None Response Time
: N.A Think Time : N.A Minimum Instruction Time : 0

Correct Marks : 1 Wrong Marks : 0

Which of the following cannot be considered as an intrusive method of traffic data collection

Options :

34058019417. ✘ Loop detector

34058019418. ✘ Moving observer

34058019419. ✘ Weigh-in Motion technology

34058019420. ✔ Infrared based

Question Number : 56 Question Id : 3405804856 Question Type : MCQ Option Shuffling : Yes
Display Question Number : Yes Is Question Mandatory : No Calculator : None Response Time
: N.A Think Time : N.A Minimum Instruction Time : 0

Correct Marks : 1 Wrong Marks : 0

The nature of flow for a discharge of $2.5 \text{ m}^3/\text{s}$ through a rectangular open channel of bottom width 1 m and depth 5 m is:

Options :

34058019421. ✘ Critical.

34058019422. ✘ Supercritical.

34058019423. ✔ Subcritical.

34058019424. ✘ Depends upon the nature of fluid

Question Number : 57 Question Id : 3405804857 Question Type : MCQ Option Shuffling : Yes
Display Question Number : Yes Is Question Mandatory : No Calculator : None Response Time
: N.A Think Time : N.A Minimum Instruction Time : 0

Correct Marks : 1 Wrong Marks : 0

The term alternate depths is used in open channel flow to denote the depths

Options :

34058019425. ✘ Having the same kinetic energy for a given discharge

34058019426. ✘ Having the same specific force for a given discharge

34058019427. ✔ Having the same specific energy for a given discharge

34058019428. ✘ Having the same total energy for a given discharge

Question Number : 58 Question Id : 3405804858 Question Type : MCQ Option Shuffling : Yes
Display Question Number : Yes Is Question Mandatory : No Calculator : None Response Time
: N.A Think Time : N.A Minimum Instruction Time : 0

Correct Marks : 1 Wrong Marks : 0

The critical flow condition in a channel is given by

Options :

34058019429. ✘ $QT^2/gA^2=1$

34058019430. ✘ $Q^2T^2/gA^2=1$

34058019431. ✔ $Q^2T/gA^3=1$

34058019432. ✖ $QT/gA^3 = 1$

Question Number : 59 Question Id : 3405804859 Question Type : MCQ Option Shuffling : Yes Display Question Number : Yes Is Question Mandatory : No Calculator : None Response Time : N.A Think Time : N.A Minimum Instruction Time : 0

Correct Marks : 1 Wrong Marks : 0

Hydraulic jump occurs when the

Options :

34058019433. ✖ Channel bed is smooth

34058019434. ✔ Flow changes from supercritical to subcritical

34058019435. ✖ Flow changes from subcritical to super critical

34058019436. ✖ Slope of bed changes from steep to mild slope

Question Number : 60 Question Id : 3405804860 Question Type : MCQ Option Shuffling : Yes Display Question Number : Yes Is Question Mandatory : No Calculator : None Response Time : N.A Think Time : N.A Minimum Instruction Time : 0

Correct Marks : 1 Wrong Marks : 0

A short RC column of size 300 x 300 mm is made of M20 concrete and is reinforced with 4 bars of 20 mm diameter Fe415 steel. The ultimate load carrying capacity of the column with zero eccentricity as per IS 456:2000 is

Options :

34058019437. ✔ 1200 kN

34058019438. ✖ 1500 kN

34058019439. ✖ 1707 kN

34058019440. ✖ 1108 kN

Question Number : 61 Question Id : 3405804861 Question Type : MCQ Option Shuffling : Yes Display Question Number : Yes Is Question Mandatory : No Calculator : None Response Time : N.A Think Time : N.A Minimum Instruction Time : 0

Correct Marks : 1 Wrong Marks : 0

A RC beam of size 300 x 600 mm is pre-stressed by 4 of 14 mm diameters bars of high tensile steel located at 150 mm from the soffit of the beam. The net stress in the bars is 750 MPa. The maximum bending moment that can be applied at the section with no tension at the soffit of the beam is

Options :

34058019441. ✖ 126.4 kNm

34058019442. ✖ 104.3 kNm

34058019443. ✖ 158.6 kNm

34058019444. ✔ 115.6 kNm

Question Number : 62 Question Id : 3405804862 Question Type : MCQ Option Shuffling : Yes Display Question Number : Yes Is Question Mandatory : No Calculator : None Response Time : N.A Think Time : N.A Minimum Instruction Time : 0

Correct Marks : 1 Wrong Marks : 0

A RC beam post tensioned by a cable carrying a pre-stress of 900 MPa. At the jacking end, the slip was observed to be 8 mm. The percentage loss of stress due to anchorage slip if length of beam is 20 m and modulus of elasticity 210 kN/mm^2 is

Options :

34058019445. ✘ 11.88%

34058019446. ✔ 9.33%

34058019447. ✘ 15.12%

34058019448. ✘ 12.54%

Question Number : 63 Question Id : 3405804863 Question Type : MCQ Option Shuffling : Yes
Display Question Number : Yes Is Question Mandatory : No Calculator : None Response Time
: N.A Think Time : N.A Minimum Instruction Time : 0

Correct Marks : 1 Wrong Marks : 0

Two triangular wedges are glued together as shown in the following figure
The stress acting normal to the interface, σ_n (in MPa) is

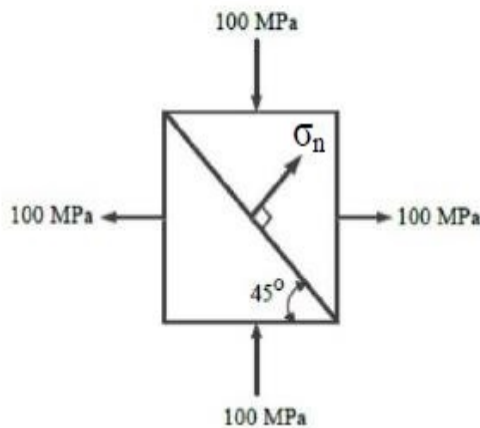

Options :

34058019449. ✔ 0

34058019450. ✘ 100

34058019451. ✘ 50

34058019452. ✘ 200

Question Number : 64 Question Id : 3405804864 Question Type : MCQ Option Shuffling : Yes
Display Question Number : Yes Is Question Mandatory : No Calculator : None Response Time : N.A Think Time : N.A Minimum Instruction Time : 0

Correct Marks : 1 Wrong Marks : 0

A bracket plate connected to a column flange transmits a load of 100 kN as shown in the following figure. The maximum force (in kN) for which the bolts should be designed is

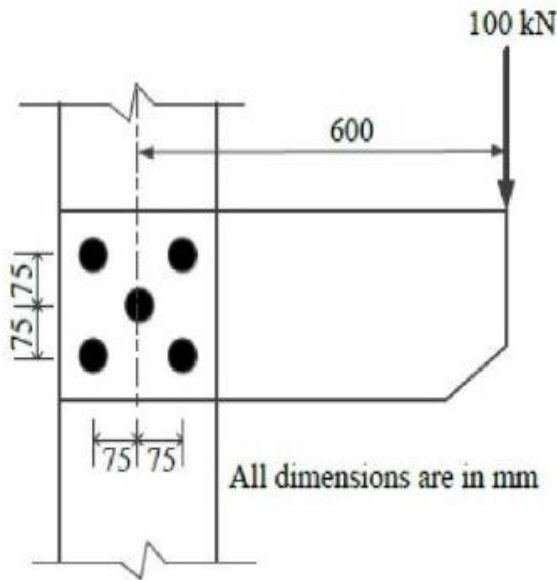

Options :

34058019453. ✘ 100

34058019454. ✘ 140

34058019455. ✔ 156

34058019456. ✘ 165

Question Number : 65 Question Id : 3405804865 Question Type : MCQ Option Shuffling : Yes
Display Question Number : Yes Is Question Mandatory : No Calculator : None Response Time : N.A Think Time : N.A Minimum Instruction Time : 0

Correct Marks : 1 Wrong Marks : 0

In a shrinkage limit test, the dry pat of soil is weighed 38 g with a volume of 18 cc. Taking the specific gravity of soil solids as 2.68, the shrinkage limit of soil is

Options :

34058019457. ✘ 12%

34058019458. ✘ 15%

34058019459. ✘ 8%

34058019460. ✔ 10%

Question Number : 66 Question Id : 3405804866 Question Type : MCQ Option Shuffling : Yes Display Question Number : Yes Is Question Mandatory : No Calculator : None Response Time : N.A Think Time : N.A Minimum Instruction Time : 0

Correct Marks : 1 Wrong Marks : 0

A 3 m x 2.5 m size of rectangular footing is subjected to a UDL of 400 kPa. The vertical stress at 4 m depth below the centre of footing is _____. Take the influence factor for vertical stress below the corner of 1.5 m x 1.25 m size of footing as 0.12

Options :

34058019461. ✔ 192 kPa

34058019462. ✘ 48 kPa

34058019463. ✘ 200 kPa

34058019464. ✘ 400 kPa

Question Number : 67 Question Id : 3405804867 Question Type : MCQ Option Shuffling : Yes
Display Question Number : Yes Is Question Mandatory : No Calculator : None Response Time
: N.A Think Time : N.A Minimum Instruction Time : 0

Correct Marks : 1 Wrong Marks : 0

What is the length of the curve and long chord distance for circular curve with two straight road segments with angle of intersection of 60° and radius of curve is 210 m

Options :

34058019465. ✓ Length of curve is 220 m and Length of long chord is 210 m

34058019466. ✗ Length of curve is 210 m and Length of long chord is 220 m

34058019467. ✗ Length of the curve is 110 m Length of long chord is 105 m

34058019468. ✗ Length of the curve is 105 m Length of long chord is 110 m

Question Number : 68 Question Id : 3405804868 Question Type : MCQ Option Shuffling : Yes
Display Question Number : Yes Is Question Mandatory : No Calculator : None Response Time
: N.A Think Time : N.A Minimum Instruction Time : 0

Correct Marks : 1 Wrong Marks : 0

Daily variations of temperature changes across the thickness of the rigid pavement slab result in

Options :

34058019469. ✗ Frictional stresses

34058019470. ✓ Warping stresses

34058019471. ✗ Subgrade reaction

34058019472. ✘ Load stress

Question Number : 69 Question Id : 3405804869 Question Type : MCQ Option Shuffling : Yes Display Question Number : Yes Is Question Mandatory : No Calculator : None Response Time : N.A Think Time : N.A Minimum Instruction Time : 0

Correct Marks : 1 Wrong Marks : 0

The lateral distribution factor for intermediate lane high volume single carriageway roads is

Options :

34058019473. ✘ 0.40

34058019474. ✘ 0.50

34058019475. ✔ 0.75

34058019476. ✘ 1.0

Question Number : 70 Question Id : 3405804870 Question Type : MCQ Option Shuffling : Yes Display Question Number : Yes Is Question Mandatory : No Calculator : None Response Time : N.A Think Time : N.A Minimum Instruction Time : 0

Correct Marks : 1 Wrong Marks : 0

To prevent the washing out of the material through filter

Options :

34058019477. ✔ Riprap is provided

34058019478. ✘ Turfing is provided

34058019479. ✘ Berm is provided

34058019480. ✘ No need to provide anything

Question Number : 71 Question Id : 3405804871 Question Type : MCQ Option Shuffling : Yes
Display Question Number : Yes Is Question Mandatory : No Calculator : None Response Time
: N.A Think Time : N.A Minimum Instruction Time : 0

Correct Marks : 1 Wrong Marks : 0

An aeration basin with a volume of 400 m^3 contains mixed liquor with suspended solid concentration of 1000 mg/l . The amount of mixed liquor suspended solids in the tank is _____

Options :

34058019481. ✘ 500 kg

34058019482. ✘ 250 kg

34058019483. ✘ 6600 kg

34058019484. ✔ 400 kg

Question Number : 72 Question Id : 3405804872 Question Type : MCQ Option Shuffling : Yes
Display Question Number : Yes Is Question Mandatory : No Calculator : None Response Time
: N.A Think Time : N.A Minimum Instruction Time : 0

Correct Marks : 1 Wrong Marks : 0

Dynamic similarities are said to exist between two fluid flows when at corresponding points there are

Options :

34058019485. ✔ Similarity of forces involved

34058019486. ✘ Kinematic similarity and dynamic similarity

34058019487. ✖ Interaction of inertia and viscous forces

34058019488. ✖ Interaction of inertia, viscous and pressure forces

Question Number : 73 Question Id : 3405804873 Question Type : MCQ Option Shuffling : Yes
Display Question Number : Yes Is Question Mandatory : No Calculator : None Response Time
: N.A Think Time : N.A Minimum Instruction Time : 0

Correct Marks : 1 Wrong Marks : 0

Two beams are connected by a linear spring as shown in the following figure. For a load P , the percentage of load carried by the spring is

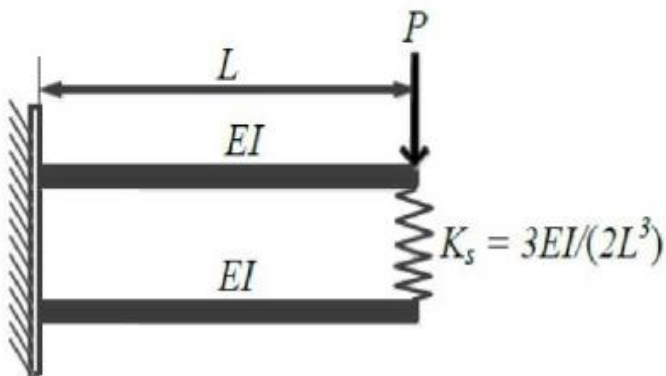

Options :

34058019489. ✖ 50

34058019490. ✔ 33

34058019491. ✖ 75

34058019492. ✖ 40

Question Number : 74 Question Id : 3405804874 Question Type : MCQ Option Shuffling : Yes
Display Question Number : Yes Is Question Mandatory : No Calculator : None Response Time

: N.A Think Time : N.A Minimum Instruction Time : 0

Correct Marks : 1 Wrong Marks : 0

The beam of overall depth 250 mm as shown in the following figure is used in a building subjected to differential thermal environments. The temperatures at top and bottom surfaces of the beam are 36°C and 72°C respectively. Consider the coefficient of the thermal expansion as 1.5×10^{-5} per $^{\circ}\text{C}$, the vertical deflection of the beam (in mm) at its mid-span due to the temperature gradient is

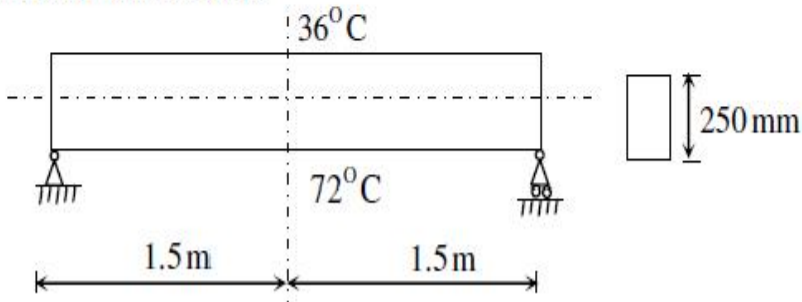

Options :

34058019493. ✘ 1.22

34058019494. ✘ 2.10

34058019495. ✔ 2.43

34058019496. ✘ 1.75

Question Number : 75 Question Id : 3405804875 Question Type : MCQ Option Shuffling : Yes

Display Question Number : Yes Is Question Mandatory : No Calculator : None Response Time

: N.A Think Time : N.A Minimum Instruction Time : 0

Correct Marks : 1 Wrong Marks : 0

Two steel columns P (length L and yield strength $f_y = 250$ MPa) and Q (length $2L$ and yield strength $f_y = 500$ MPa) have same cross-sectional area and end conditions. The ratio of Euler buckling load of column P to that of column Q is

Options :

34058019497. ✖ 0.5

34058019498. ✖ 1.0

34058019499. ✖ 2.0

34058019500. ✔ 4.0

Question Number : 76 Question Id : 3405804876 Question Type : MCQ Option Shuffling : Yes Display Question Number : Yes Is Question Mandatory : No Calculator : None Response Time : N.A Think Time : N.A Minimum Instruction Time : 0

Correct Marks : 1 Wrong Marks : 0

A uniform wheel of 600 mm diameter, weighing 5 kN rests against a rigid rectangular block of 150 mm as shown in the figure. The least pull (in kN) required through the centre of the wheel just to turn the wheel over the corner A of the block is

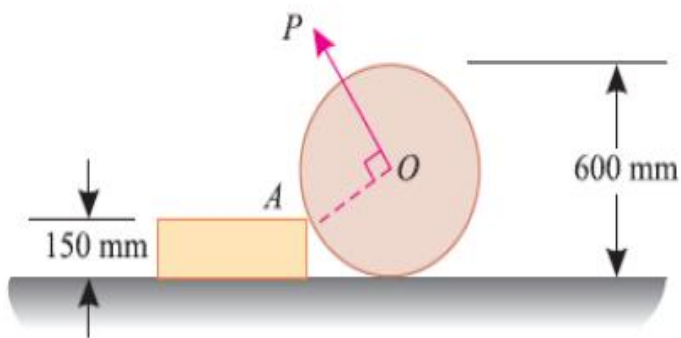

Options :

34058019501. ✖ 2.82

34058019502. ✖ 4.98

34058019503. ✔ 4.33

34058019504. ✖ 3.68

Question Number : 77 Question Id : 3405804877 Question Type : MCQ Option Shuffling : Yes
Display Question Number : Yes Is Question Mandatory : No Calculator : None Response Time
: N.A Think Time : N.A Minimum Instruction Time : 0

Correct Marks : 1 Wrong Marks : 0

The Skempton's pore pressure parameters for an embankment soil are obtained as $A = 0.40$ and $B = 0.92$. The increase in pore pressure when the embankment is raised from 2 m to 5 m height is about _____. Take the bulk unit weight of soil as 16 kN/m^3 and the increase in the confining pressure as half of the increase in vertical pressure

Options :

34058019505. ✘ 44 kPa

34058019506. ✘ 24 kPa

34058019507. ✔ 31 kPa

34058019508. ✘ 19 kPa

Question Number : 78 Question Id : 3405804878 Question Type : MCQ Option Shuffling : Yes
Display Question Number : Yes Is Question Mandatory : No Calculator : None Response Time
: N.A Think Time : N.A Minimum Instruction Time : 0

Correct Marks : 1 Wrong Marks : 0

A clay layer is settled by 2 cm when the effective stress is increased from 1 kg/cm^2 to 2 kg/cm^2 . What would be the total settlement when the effective stress is increased to 8 kg/cm^2 using C_c approach

Options :

34058019509. ✘ 3 cm

34058019510. ✘ 8 cm

34058019511. ✘ 4 cm

34058019512. ✔ 6 cm

Question Number : 79 Question Id : 3405804879 Question Type : MCQ Option Shuffling : Yes Display Question Number : Yes Is Question Mandatory : No Calculator : None Response Time : N.A Think Time : N.A Minimum Instruction Time : 0

Correct Marks : 1 Wrong Marks : 0

The granular material used for construction of drainage layer is considered as very good when

Options :

34058019513. ✘ D_{15} of drainage layer $\leq 5 \times D_{50}$ of sub-grade and D_{50} of drainage layer $\geq 25 \times D_{50}$ of sub-grade

34058019514. ✘ D_{15} of drainage layer $\leq 5 \times D_{15}$ of sub-grade and D_{50} of drainage layer $\geq 5 \times D_{50}$ of sub-grade

34058019515. ✔ D_{15} of drainage layer $\geq 5 \times D_{15}$ of sub-grade and D_{50} of drainage layer $\leq 5 \times D_{50}$ of sub-grade

34058019516. ✘ D_{85} of drainage layer $\leq 4 \times D_{50}$ of sub-grade and D_2 of drainage layer ≥ 2.5 mm

Question Number : 80 Question Id : 3405804880 Question Type : MCQ Option Shuffling : Yes Display Question Number : Yes Is Question Mandatory : No Calculator : None Response Time : N.A Think Time : N.A Minimum Instruction Time : 0

Correct Marks : 1 Wrong Marks : 0

In hydraulic modelling of flow pattern around a body submerged in a fluid the non-dimensional number which has to be kept the same in the model and prototype is

Options :

34058019517. ✘ Weber number

34058019518. ✘ Froude number

34058019519. ✔ Reynolds number

34058019520. ✘ Mach number

Question Number : 81 Question Id : 3405804881 Question Type : MCQ Option Shuffling : Yes Display Question Number : Yes Is Question Mandatory : No Calculator : None Response Time : N.A Think Time : N.A Minimum Instruction Time : 0

Correct Marks : 1 Wrong Marks : 0

Based on the given data, calculate number of years from now when the water treatment plant will reach its design capacity, assuming an arithmetic rate of population growth

Present population = 32000, Average water consumption (m^3/d) = 4000

Expected population in next 20 year = 48000, Design capacity of existing treatment plant (m^3/d) = 6500

Options :

34058019521. ✘ 15

34058019522. ✘ 20

34058019523. ✔ 25

34058019524. ✖ 30

Question Number : 82 Question Id : 3405804882 Question Type : MCQ Option Shuffling : Yes
Display Question Number : Yes Is Question Mandatory : No Calculator : None Response Time : N.A Think Time : N.A Minimum Instruction Time : 0
Correct Marks : 1 Wrong Marks : 0

A string ABCD attached to fixed points A and D has two equal weights of 1000 N at B and C as shown in the figure below. The weights rest with the portions AB and CD inclined at angles as shown in the figure. The tension (in N) in the portion BC of the string is

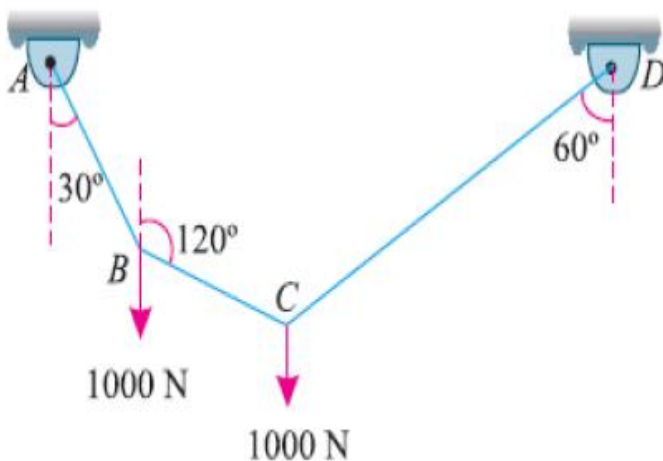

Options :

34058019525. ✖ 500

34058019526. ✔ 1000

34058019527. ✖ 750

34058019528. ✖ 0

Question Number : 83 Question Id : 3405804883 Question Type : MCQ Option Shuffling : Yes

Display Question Number : Yes Is Question Mandatory : No Calculator : None Response Time : N.A Think Time : N.A Minimum Instruction Time : 0

Correct Marks : 1 Wrong Marks : 0

A uniform ladder 3 m long weighs 200 N. It is placed against a wall making an angle of 60° with the floor as shown in the figure below. The coefficient of friction between the wall and ladder is 0.25 and that between the floor and the ladder is 0.35. The ladder in addition to its self-weight, has to support a man of 1000 N at its top at B as shown in the figure. The horizontal force (in N) to be applied to ladder at the floor level to prevent slipping is

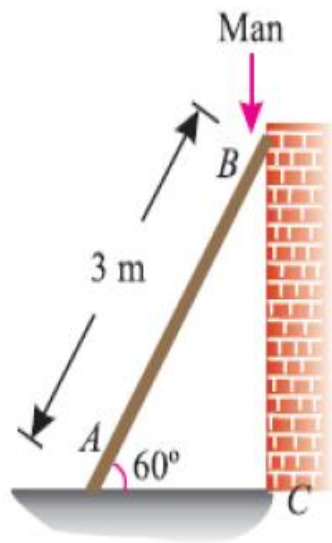

Options :

34058019529. ✓ 183.5

34058019530. ✗ 100.0

34058019531. ✗ 125.6

34058019532. ✗ 164.8

Question Number : 84 Question Id : 3405804884 Question Type : MCQ Option Shuffling : Yes Display Question Number : Yes Is Question Mandatory : No Calculator : None Response Time : N.A Think Time : N.A Minimum Instruction Time : 0

Correct Marks : 1 Wrong Marks : 0

An engine of mass 50 tonnes pulls a train of mass 300 tonnes up an incline of 1 in 100 as shown in figure below. The train starts from rest and moves with a constant acceleration against a total resistance of 50 newtons per tonnes. If the train attains a speed of 36 kmph. in a distance of 1 kilometre, the power of the engine (in kW) is

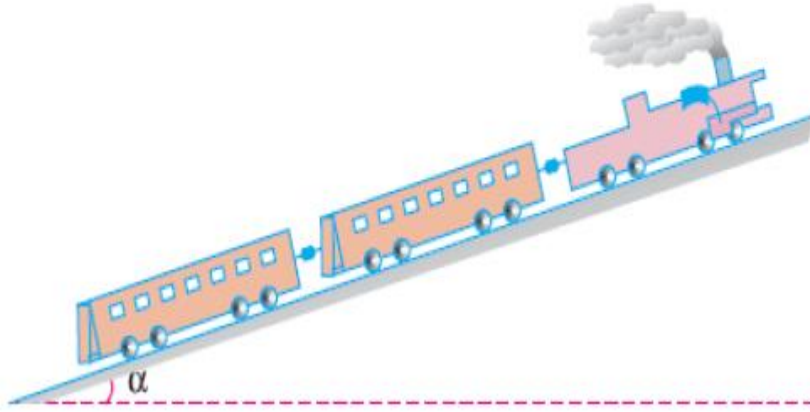

Options :

34058019533. ✘ 752

34058019534. ✘ 650

34058019535. ✘ 875

34058019536. ✔ 693

Question Number : 85 Question Id : 3405804885 Question Type : MCQ Option Shuffling : Yes Display Question Number : Yes Is Question Mandatory : No Calculator : None Response Time : N.A Think Time : N.A Minimum Instruction Time : 0

Correct Marks : 1 Wrong Marks : 0

Raft foundations are used when the total area of individual footings of a building is

Options :

34058019537. ✘ Less than 50 % of loaded area

34058019538. ✓ More than 50 % of loaded area

34058019539. ✗ Less than 75 % of loaded area

34058019540. ✗ More than 75 % of loaded area

**Question Number : 86 Question Id : 3405804886 Question Type : MCQ Option Shuffling : Yes
Display Question Number : Yes Is Question Mandatory : No Calculator : None Response Time
: N.A Think Time : N.A Minimum Instruction Time : 0**

Correct Marks : 1 Wrong Marks : 0

The load carrying capacity of an individual friction pile is 160 kN. What is the total carrying capacity of a group of 9 such piles with group efficiency factor of 0.85

Options :

34058019541. ✗ 1440 kN

34058019542. ✓ 1224 kN

34058019543. ✗ 1640 kN

34058019544. ✗ 900 kN

**Question Number : 87 Question Id : 3405804887 Question Type : MCQ Option Shuffling : Yes
Display Question Number : Yes Is Question Mandatory : No Calculator : None Response Time
: N.A Think Time : N.A Minimum Instruction Time : 0**

Correct Marks : 1 Wrong Marks : 0

The mean unconfined compressive strength of a purely cohesive soil was found to be 50 kN/m². The Net ultimate bearing capacity of a strip footing calculated by Terzaghi's concept (bearing capacity factor $N_c = 5.7$) will be

Options :

34058019545. ✘ 185.25 kN/m²

34058019546. ✘ 390.5 kN/m²

34058019547. ✘ 285 kN/m²

34058019548. ✔ 142.5 kN/m²

**Question Number : 88 Question Id : 3405804888 Question Type : MCQ Option Shuffling : Yes
Display Question Number : Yes Is Question Mandatory : No Calculator : None Response Time
: N.A Think Time : N.A Minimum Instruction Time : 0**

Correct Marks : 1 Wrong Marks : 0

As per International Civil Aviation Organisation, the corrected length of runway for an airport located at mean sea level and airport reference temperature 32.6 degree celsius is _____. The uncorrected length of runway is L

Options :

34058019549. ✘ 1.576 L

34058019550. ✘ 1.35 L

34058019551. ✔ 1.176 L

34058019552. ✘ 2 L

**Question Number : 89 Question Id : 3405804889 Question Type : MCQ Option Shuffling : Yes
Display Question Number : Yes Is Question Mandatory : No Calculator : None Response Time
: N.A Think Time : N.A Minimum Instruction Time : 0**

Correct Marks : 1 Wrong Marks : 0

In the geometric design of railway tracks, grade compensation on curves for a broad gauge track is

Options :

34058019553. ✘ 0.04 percent per degree of the curve or $52.5/R$, whichever is minimum

34058019554. ✔ 0.04 percent per degree of the curve or $70/R$, whichever is minimum

34058019555. ✘ 0.02 percent per degree of the curve or $35/R$, whichever is minimum

34058019556. ✘ 0.03 percent per degree of the curve or $70/R$, whichever is minimum

Question Number : 90 Question Id : 3405804890 Question Type : MCQ Option Shuffling : Yes Display Question Number : Yes Is Question Mandatory : No Calculator : None Response Time : N.A Think Time : N.A Minimum Instruction Time : 0

Correct Marks : 1 Wrong Marks : 0

If the Marshall stability for bituminous concrete is 10 kN and the corresponding Marshall flow is 2.5 mm, then the Marshall Quotient is

Options :

34058019557. ✘ 0.25

34058019558. ✔ 4.0

34058019559. ✘ 25.0

34058019560. ✘ 12.5

Question Number : 91 Question Id : 3405804891 Question Type : MCQ Option Shuffling : Yes

Display Question Number : Yes Is Question Mandatory : No Calculator : None Response Time : N.A Think Time : N.A Minimum Instruction Time : 0

Correct Marks : 1 Wrong Marks : 0

Match the given water properties in group I to the given titrants in Group II

Group I	Group II
P. Dissolved oxygen	1. N/40 $\text{Na}_2\text{S}_2\text{O}_3$
Q. Chloride	2. N/50 H_2SO_4
R. Alkalinity	3. N/50 EDTA
S. Hardness	4. N/71 AgNO_3

Options :

34058019561. ✘ P-1, Q-2, R-3, S-4

34058019562. ✘ P-2, Q-1, R-4, S-3

34058019563. ✘ P-3, Q-4, R-1, S-2

34058019564. ✔ P-1, Q-4, R-2, S-3

Question Number : 92 Question Id : 3405804892 Question Type : MCQ Option Shuffling : Yes Display Question Number : Yes Is Question Mandatory : No Calculator : None Response Time : N.A Think Time : N.A Minimum Instruction Time : 0

Correct Marks : 1 Wrong Marks : 0

The 5 day BOD of a wastewater sample is obtained as 190 mg/l with $k=0.01\text{h}^{-1}$. The ultimate oxygen demand (mg/l) of the sample will be _____

Options :

34058019565. ✘ 3800

34058019566. ✘ 475

34058019567. ✓ 271

34058019568. ✘ 190

Question Number : 93 Question Id : 3405804893 Question Type : MCQ Option Shuffling : Yes Display Question Number : Yes Is Question Mandatory : No Calculator : None Response Time : N.A Think Time : N.A Minimum Instruction Time : 0

Correct Marks : 1 Wrong Marks : 0

The MLSS concentration in an aeration is 2000 mg/l and the sludge volume after 30 minutes of settling in a 1000 ml graduated cylinder is 176 ml, then the SVI is _____.

Options :

34058019569. ✓ 88 ml/gm

34058019570. ✘ 176 ml/gm

34058019571. ✘ 200 ml/gm

34058019572. ✘ 0 ml/gm

Question Number : 94 Question Id : 3405804894 Question Type : MCQ Option Shuffling : Yes Display Question Number : Yes Is Question Mandatory : No Calculator : None Response Time : N.A Think Time : N.A Minimum Instruction Time : 0

Correct Marks : 1 Wrong Marks : 0

Seasoning of timber is a process in which

Options :

34058019573. ✓ Removal of moisture from freshly cut tree

34058019574. ✘ Burning of timber

34058019575. ✘ Watering of timber

34058019576. ✘ Cutting of timber

Question Number : 95 Question Id : 3405804895 Question Type : MCQ Option Shuffling : Yes
Display Question Number : Yes Is Question Mandatory : No Calculator : None Response Time
: N.A Think Time : N.A Minimum Instruction Time : 0

Correct Marks : 1 Wrong Marks : 0

The type of bond used in the figure below in brick masonry is

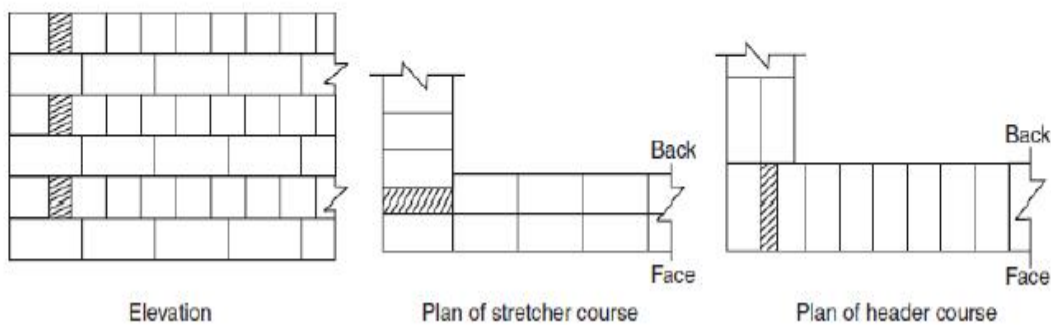

Options :

34058019577. ✘ Flemish bond

34058019578. ✔ English bond

34058019579. ✘ Header bond

34058019580. ✘ Stretcher bond

Question Number : 96 Question Id : 3405804896 Question Type : MCQ Option Shuffling : Yes

Display Question Number : Yes Is Question Mandatory : No Calculator : None Response Time : N.A Think Time : N.A Minimum Instruction Time : 0

Correct Marks : 1 Wrong Marks : 0

The relationship between number of risers (R) and treads (T) in a staircase is

Options :

34058019581. ✘ $R+T=1$

34058019582. ✘ $T=R+1$

34058019583. ✔ $R=T+1$

34058019584. ✘ $R-T=0$

Question Number : 97 Question Id : 3405804897 Question Type : MCQ Option Shuffling : Yes Display Question Number : Yes Is Question Mandatory : No Calculator : None Response Time : N.A Think Time : N.A Minimum Instruction Time : 0

Correct Marks : 1 Wrong Marks : 0

Maximum permissible settlement for isolated foundation of RCC structures on sand as stipulated by I.S 1904 code is

Options :

34058019585. ✔ 50 mm

34058019586. ✘ 75 mm

34058019587. ✘ 10 mm

34058019588. ✘ 100 mm

Question Number : 98 Question Id : 3405804898 Question Type : MCQ Option Shuffling : Yes Display Question Number : Yes Is Question Mandatory : No Calculator : None Response Time : N.A Think Time : N.A Minimum Instruction Time : 0

Correct Marks : 1 Wrong Marks : 0

For under-ream piles of up to 0.3 m diameter, the maximum vertical spacing between two under-reams, of diameter D_u , as per IS: 2911 (Part III) - 1980 is

Options :

34058019589. ✘ 1.25 D_u

34058019590. ✔ 1.5 D_u

34058019591. ✘ 2.0 D_u

34058019592. ✘ 2.5 D_u

Question Number : 99 Question Id : 3405804899 Question Type : MCQ Option Shuffling : Yes Display Question Number : Yes Is Question Mandatory : No Calculator : None Response Time : N.A Think Time : N.A Minimum Instruction Time : 0

Correct Marks : 1 Wrong Marks : 0

A 300 mm square bearing plate settles by 20 mm in a plate load test on a cohesive soil when the intensity of loading is 0.25 N/mm^2 . The settlement of a prototype shallow footing 1.2 m square under the same intensity of loading is

Options :

34058019593. ✘ 40 mm

34058019594. ✘ 50 mm

34058019595. ✘ 70 mm

34058019596. ✔ 80 mm

Question Number : 100 Question Id : 3405804900 Question Type : MCQ Option Shuffling : Yes Display Question Number : Yes Is Question Mandatory : No Calculator : None Response Time : N.A Think Time : N.A Minimum Instruction Time : 0

Correct Marks : 1 Wrong Marks : 0

What is the value of modules of dowel bar support recommended for determination of dowel bar deflection of the face of the joint

Options :

34058019597. ✘ 125 mPa/m

34058019598. ✘ 200 mPa/m

34058019599. ✘ 30000 mPa/m

34058019600. ✔ 415200 mPa/m

Question Number : 101 Question Id : 3405804901 Question Type : MCQ Option Shuffling : Yes Display Question Number : Yes Is Question Mandatory : No Calculator : None Response Time : N.A Think Time : N.A Minimum Instruction Time : 0

Correct Marks : 1 Wrong Marks : 0

In an activated sludge system for the given data (i) the volume of the reactor= 1600 m^3 (ii) mean cell residence time = 10 days (iii) MLSS concentration of 3000 mg/L and an underflow concentration of 10000 mg/L from the secondary clarifier. Determine the mass of solids that must be wasted each day

Options :

34058019601. ✘ 48 kg/d

34058019602. ✘ 160 kg/d

34058019603. ✔ 480 kg/d

34058019604. ✘ 1600 kg/d

Question Number : 102 Question Id : 3405804902 Question Type : MCQ Option Shuffling : Yes Display Question Number : Yes Is Question Mandatory : No Calculator : None Response Time : N.A Think Time : N.A Minimum Instruction Time : 0

Correct Marks : 1 Wrong Marks : 0

Bulking sludge refers to having

Options :

34058019605. ✘ $F/M = \text{zero}$

34058019606. ✔ $F/M < 0.3/d$

34058019607. ✘ $0.3/d < F/M < 0.6/d$

34058019608. ✘ $F/M > 0.6/d$

Question Number : 103 Question Id : 3405804903 Question Type : MCQ Option Shuffling : Yes Display Question Number : Yes Is Question Mandatory : No Calculator : None Response Time : N.A Think Time : N.A Minimum Instruction Time : 0

Correct Marks : 1 Wrong Marks : 0

A sample of air analyzed at 0°C and 1 atmospheric pressure is reported to contain 9 ppm of CO. Determine the equivalent CO concentration in $\mu\text{g}/\text{m}^3$.

Options :

34058019609. ✖ 11.25

34058019610. ✖ 9

34058019611. ✔ 11250

34058019612. ✖ 112.5

**Question Number : 104 Question Id : 3405804904 Question Type : MCQ Option Shuffling : Yes
Display Question Number : Yes Is Question Mandatory : No Calculator : None Response Time
: N.A Think Time : N.A Minimum Instruction Time : 0**

Correct Marks : 1 Wrong Marks : 0

If the standard consistency of cement is 32%, the amount of water to be used for conducting the initial setting time test on cement (in %) is

Options :

34058019613. ✖ 30.51

34058019614. ✔ 27.28

34058019615. ✖ 25.62

34058019616. ✖ 32.32

**Question Number : 105 Question Id : 3405804905 Question Type : MCQ Option Shuffling : Yes
Display Question Number : Yes Is Question Mandatory : No Calculator : None Response Time
: N.A Think Time : N.A Minimum Instruction Time : 0**

Correct Marks : 1 Wrong Marks : 0

Consider the following oxides:

1. Al_2O_3 , 2. CaO , 3. SiO_2

The correct sequence in increasing order of their percentage in an ordinary Portland cement is

Options :

34058019617. ✖ 2,1,3

34058019618. ✔ 1,3,2

34058019619. ✖ 3,1,2

34058019620. ✖ 1,2,3

Question Number : 106 Question Id : 3405804906 Question Type : MCQ Option Shuffling : Yes Display Question Number : Yes Is Question Mandatory : No Calculator : None Response Time : N.A Think Time : N.A Minimum Instruction Time : 0

Correct Marks : 1 Wrong Marks : 0

A 18 mm thick plate is joined to a 16 mm plate by 200 mm long (effective) single V butt weld. The strength (in kN) of the joint if Fe410 grade plates and shop welds are used is

Options :

34058019621. ✔ 379

34058019622. ✖ 302

34058019623. ✖ 287

34058019624. ✖ 415

Question Number : 107 Question Id : 3405804907 Question Type : MCQ Option Shuffling : Yes
Display Question Number : Yes Is Question Mandatory : No Calculator : None Response Time : N.A Think Time : N.A Minimum Instruction Time : 0
Correct Marks : 1 Wrong Marks : 0

The design strength (in kN) due to yielding of gross section of a plate 130 x 12 mm thick with the holes for 16 mm diameter bolts as shown in the figure below is

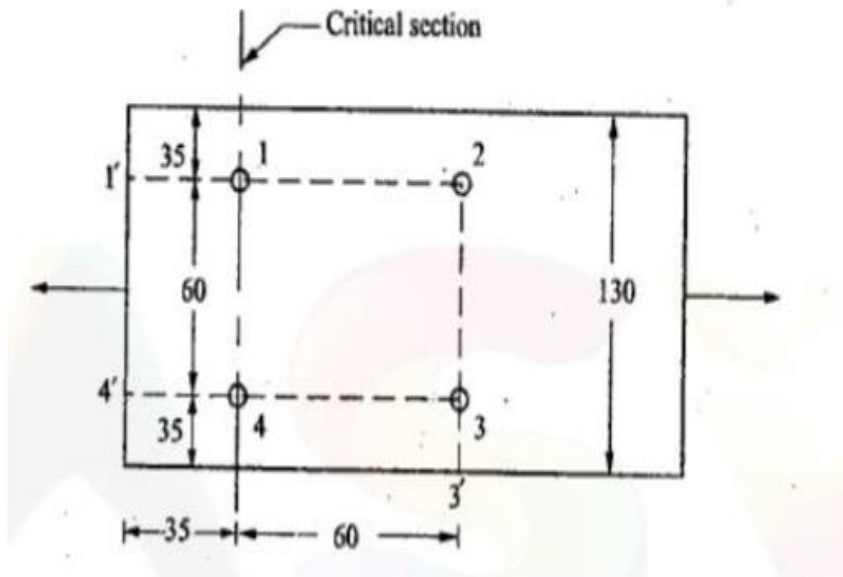

Options :

34058019625. ✘ 278

34058019626. ✘ 256

34058019627. ✘ 312

34058019628. ✔ 355

Question Number : 108 Question Id : 3405804908 Question Type : MCQ Option Shuffling : Yes
Display Question Number : Yes Is Question Mandatory : No Calculator : None Response Time : N.A Think Time : N.A Minimum Instruction Time : 0
Correct Marks : 1 Wrong Marks : 0

The settlement of a 4 m thick clayey soil (Coefficient of volume change = $0.3 \text{ mm}^2/\text{N}$) when the pressure increment at the center of the compressible stratum is 0.09 N/mm^2 is

Options :

34058019629. ✘ 54 mm

34058019630. ✘ 90 mm

34058019631. ✘ 100 mm

34058019632. ✔ 108 mm

Question Number : 109 Question Id : 3405804909 Question Type : MCQ Option Shuffling : Yes Display Question Number : Yes Is Question Mandatory : No Calculator : None Response Time : N.A Think Time : N.A Minimum Instruction Time : 0

Correct Marks : 1 Wrong Marks : 0

As per Terzaghi's theory, the ultimate bearing capacity of 1.5 m wide strip footing resting on the surface of a purely cohesive soil having unconfined compressive strength value of 60 kN/m^2 is

Options :

34058019633. ✘ 60 kN/m^2

34058019634. ✘ 90 kN/m^2

34058019635. ✔ 171 kN/m^2

34058019636. ✘ 342 kN/m^2

Question Number : 110 Question Id : 3405804910 Question Type : MCQ Option Shuffling : Yes
Display Question Number : Yes Is Question Mandatory : No Calculator : None Response Time
: N.A Think Time : N.A Minimum Instruction Time : 0

Correct Marks : 1 Wrong Marks : 0

A parabolic curve is used to connect a 2.8% upgrade with 1.8% downgrade.
What is the length of vertical curve if the rate of change of grade is 0.2% per
20m chain

Options :

34058019637. ✘ 330 m

34058019638. ✘ 860 m

34058019639. ✘ 18.4 m

34058019640. ✔ 460 m

Question Number : 111 Question Id : 3405804911 Question Type : MCQ Option Shuffling : Yes
Display Question Number : Yes Is Question Mandatory : No Calculator : None Response Time
: N.A Think Time : N.A Minimum Instruction Time : 0

Correct Marks : 1 Wrong Marks : 0

The dispersion of pollutants in atmosphere is maximum when

Options :

34058019641. ✘ Maximum mixing depth is equal to zero

34058019642. ✘ Environmental lapse rate is less than adiabatic lapse rate

34058019643. ✘ Environmental lapse rate is equal to adiabatic lapse rate

34058019644. ✔ Environmental lapse rate is greater than adiabatic lapse rate

Question Number : 112 Question Id : 3405804912 Question Type : MCQ Option Shuffling : Yes Display Question Number : Yes Is Question Mandatory : No Calculator : None Response Time : N.A Think Time : N.A Minimum Instruction Time : 0

Correct Marks : 1 Wrong Marks : 0

The number of bolts required for a lap joint between two plates of 12 mm and 20 mm thick (assuming end distance, $e = 29$ mm, minimum pitch, $p = 40$ mm and thread intercept shear plane) to transmit a factored load of 90 kN is

Options :

34058019645. ✖ 3

34058019646. ✔ 4

34058019647. ✖ 2

34058019648. ✖ 5

Question Number : 113 Question Id : 3405804913 Question Type : MCQ Option Shuffling : Yes Display Question Number : Yes Is Question Mandatory : No Calculator : None Response Time : N.A Think Time : N.A Minimum Instruction Time : 0

Correct Marks : 1 Wrong Marks : 0

The time (in days) for completion of a job having optimistic time (t_o) 4 days, pessimistic time (t_p) 11 days and most likely time (t_l) 6 days is

Options :

34058019649. ✖ 10

34058019650. ✖ 11

34058019651. ✔ 6

34058019652. ✖ 4

Question Number : 114 Question Id : 3405804914 Question Type : MCQ Option Shuffling : Yes Display Question Number : Yes Is Question Mandatory : No Calculator : None Response Time : N.A Think Time : N.A Minimum Instruction Time : 0

Correct Marks : 1 Wrong Marks : 0

If the earliest expected time (t_e) and latest allowable time (t_l) for a particular event are 15 and 21 respectively, then slack of the event is

Options :

34058019653. ✔ 6

34058019654. ✖ -6

34058019655. ✖ 36

34058019656. ✖ -36

Question Number : 115 Question Id : 3405804915 Question Type : MCQ Option Shuffling : Yes Display Question Number : Yes Is Question Mandatory : No Calculator : None Response Time : N.A Think Time : N.A Minimum Instruction Time : 0

Correct Marks : 1 Wrong Marks : 0

PERT calculations yield a project length of 50 weeks with a variance of 16. The number of weeks required for the completion of project with a probability of 95% is (take the normal distribution 'Z' value for 95% probability as 1.65) is

Options :

34058019657. ✖ 42

34058019658. ✖ 49

34058019659. ✖ 53

34058019660. ✔ 57

**Question Number : 116 Question Id : 3405804916 Question Type : MCQ Option Shuffling : Yes
Display Question Number : Yes Is Question Mandatory : No Calculator : None Response Time
: N.A Think Time : N.A Minimum Instruction Time : 0**

Correct Marks : 1 Wrong Marks : 0

The maximum sound level beyond which it is regarded as pollutant

Options :

34058019661. ✖ 20 dB

34058019662. ✖ 40 dB

34058019663. ✖ 45 dB

34058019664. ✔ 80 dB

**Question Number : 117 Question Id : 3405804917 Question Type : MCQ Option Shuffling : Yes
Display Question Number : Yes Is Question Mandatory : No Calculator : None Response Time
: N.A Think Time : N.A Minimum Instruction Time : 0**

Correct Marks : 1 Wrong Marks : 0

For the CPM network as shown in the figure below, the critical path is

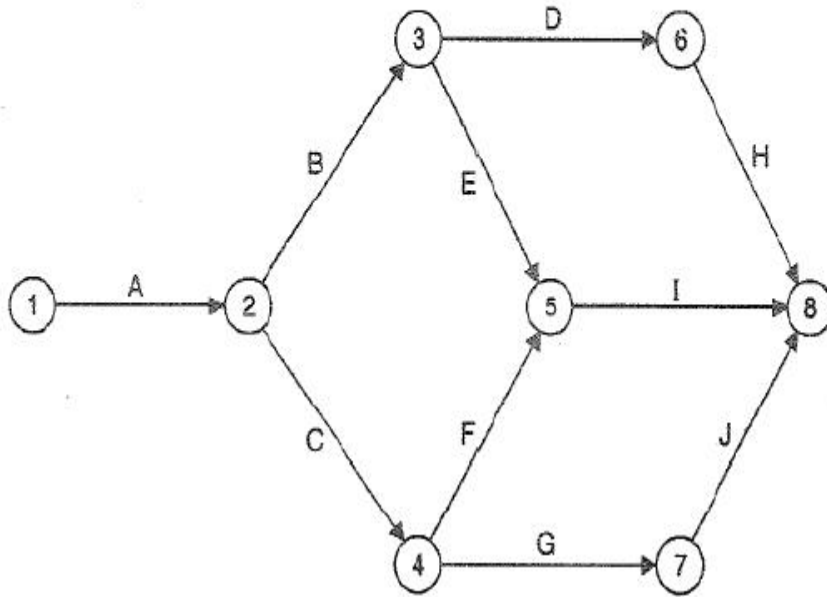

Activity	Estimated duration	Activity	Estimated duration
A	5	F	2
B	2	G	3
C	6	H	8
D	4	I	7
E	4	J	2

Options :

34058019665. ✘ 1-2, 2-3, 3-6, 6-8

34058019666. ✘ 1-2, 2-4, 4-7, 7-8

34058019667. ✔ 1-2, 2-4, 4-5, 5-8

34058019668. ✘ 1-2, 2-3, 3-5, 5-8

Question Number : 118 Question Id : 3405804918 Question Type : MCQ Option Shuffling : Yes
Display Question Number : Yes Is Question Mandatory : No Calculator : None Response Time
: N.A Think Time : N.A Minimum Instruction Time : 0

Correct Marks : 1 Wrong Marks : 0

The interior support in original beam is considered as _____ in conjugate beam

Options :

34058019669. ✘ Free end

34058019670. ✘ Fixed end

34058019671. ✔ Internal hinge

34058019672. ✘ Free roller

Question Number : 119 Question Id : 3405804919 Question Type : MCQ Option Shuffling : Yes
Display Question Number : Yes Is Question Mandatory : No Calculator : None Response Time
: N.A Think Time : N.A Minimum Instruction Time : 0

Correct Marks : 1 Wrong Marks : 0

A light cable 18 m long, is supported at two ends at the same level. The supports are 16 m apart. The cable supports 120 N load dividing the distance into two equal parts. The tension in the cable (in N) is

Options :

34058019673. ✔ 131

34058019674. ✘ 125

34058019675. ✘ 138

34058019676. ✖ 143

Question Number : 120 Question Id : 3405804920 Question Type : MCQ Option Shuffling : Yes
Display Question Number : Yes Is Question Mandatory : No Calculator : None Response Time
: N.A Think Time : N.A Minimum Instruction Time : 0

Correct Marks : 1 Wrong Marks : 0

The product of flexibility matrix and stiffness matrix is always a

Options :

34058019677. ✖ Symmetric matrix

34058019678. ✖ Skew-symmetric matrix

34058019679. ✖ Orthogonal matrix

34058019680. ✔ Identity matrix