

SECTION 1 (Maximum Marks: 24)

- This section contains **EIGHT (08)** questions.
- The answer to each question is a **NUMERICAL VALUE**.
- For each question, enter the correct numerical value of the answer using the mouse and the on-screen virtual numeric keypad in the place designated to enter the answer. If the numerical value has more than two decimal places, **truncate/round-off** the value to **TWO** decimal places.
- Answer to each question will be evaluated according to the following marking scheme:
Full Marks : +3 **ONLY** if the correct numerical value is entered;
Zero Marks : 0 In all other cases.

Q.1 Considering only the principal values of the inverse trigonometric functions, the value of

$$\frac{3}{2} \cos^{-1} \sqrt{\frac{2}{2+\pi^2}} + \frac{1}{4} \sin^{-1} \frac{2\sqrt{2}\pi}{2+\pi^2} + \tan^{-1} \frac{\sqrt{2}}{\pi}$$

is 2.36. **Range (2.35 - 2.37)**

Q.2 Let α be a positive real number. Let $f: \mathbb{R} \rightarrow \mathbb{R}$ and $g: (\alpha, \infty) \rightarrow \mathbb{R}$ be the functions defined by

$$f(x) = \sin\left(\frac{\pi x}{12}\right) \quad \text{and} \quad g(x) = \frac{2 \log_e (\sqrt{x} - \sqrt{\alpha})}{\log_e (e^{\sqrt{x}} - e^{\sqrt{\alpha}})}.$$

Then the value of $\lim_{x \rightarrow \alpha^+} f(g(x))$ is 0.50. **Range (0.49 - 0.51)**

Q.3 In a study about a pandemic, data of 900 persons was collected. It was found that

- 190 persons had symptom of fever,
- 220 persons had symptom of cough,
- 220 persons had symptom of breathing problem,
- 330 persons had symptom of fever or cough or both,
- 350 persons had symptom of cough or breathing problem or both,
- 340 persons had symptom of fever or breathing problem or both,
- 30 persons had all three symptoms (fever, cough and breathing problem).

If a person is chosen randomly from these 900 persons, then the probability that the person has at most one symptom is 0.80. **Range (0.79 - 0.81)**

Q.4 Let z be a complex number with non-zero imaginary part. If

$$\frac{2 + 3z + 4z^2}{2 - 3z + 4z^2}$$

is a real number, then the value of $|z|^2$ is 0.50. **Range (0.49 - 0.51)**

Q.5 Let \bar{z} denote the complex conjugate of a complex number z and let $i = \sqrt{-1}$. In the set of complex numbers, the number of distinct roots of the equation

$$\bar{z} - z^2 = i(\bar{z} + z^2)$$

is 4. **Range (4 - 4)**

Q.6 Let l_1, l_2, \dots, l_{100} be consecutive terms of an arithmetic progression with common difference d_1 , and let w_1, w_2, \dots, w_{100} be consecutive terms of another arithmetic progression with common difference d_2 , where $d_1 d_2 = 10$. For each $i = 1, 2, \dots, 100$, let R_i be a rectangle with length l_i , width w_i and area A_i . If $A_{51} - A_{50} = 1000$, then the value of $A_{100} - A_{90}$ is 18900. **Range (18900 - 18900)**

Q.7 The number of 4-digit integers in the closed interval $[2022, 4482]$ formed by using the digits 0, 2, 3, 4, 6, 7 is 569. **Range (569 - 569)**

Q.8 Let ABC be the triangle with $AB = 1$, $AC = 3$ and $\angle BAC = \frac{\pi}{2}$. If a circle of radius $r > 0$ touches the sides AB , AC and also touches internally the circumcircle of the triangle ABC , then the value of r is 0.84. **Range (0.82 - 0.86)**

SECTION 2 (Maximum Marks: 24)

- This section contains **SIX (06)** questions.
- Each question has **FOUR** options (A), (B), (C) and (D). **ONE OR MORE THAN ONE** of these four option(s) is(are) correct answer(s).
- For each question, choose the option(s) corresponding to (all) the correct answer(s).
- Answer to each question will be evaluated according to the following marking scheme:
Full Marks : +4 **ONLY** if (all) the correct option(s) is(are) chosen;
Partial Marks : +3 If all the four options are correct but **ONLY** three options are chosen;
Partial Marks : +2 If three or more options are correct but **ONLY** two options are chosen, both of which are correct;
Partial Marks : +1 If two or more options are correct but **ONLY** one option is chosen and it is a correct option;
Zero Marks : 0 If none of the options is chosen (i.e. the question is unanswered);
Negative Marks : -2 In all other cases.

Q.9 Consider the equation

$$\int_1^e \frac{(\log_e x)^{1/2}}{x(a - (\log_e x)^{3/2})^2} dx = 1, \quad a \in (-\infty, 0) \cup (1, \infty).$$

Which of the following statements is/are TRUE ?

- (A) No a satisfies the above equation
- (B) An integer a satisfies the above equation
- (C) An irrational number a satisfies the above equation
- (D) More than one a satisfy the above equation

Answer: C, D

Q.10 Let a_1, a_2, a_3, \dots be an arithmetic progression with $a_1 = 7$ and common difference 8. Let T_1, T_2, T_3, \dots be such that $T_1 = 3$ and $T_{n+1} - T_n = a_n$ for $n \geq 1$. Then, which of the following is/are TRUE ?

- (A) $T_{20} = 1604$ (B) $\sum_{k=1}^{20} T_k = 10510$
 (C) $T_{30} = 3454$ (D) $\sum_{k=1}^{30} T_k = 35610$

Answer: B, C

Q.11 Let P_1 and P_2 be two planes given by

$$P_1: 10x + 15y + 12z - 60 = 0,$$

$$P_2: -2x + 5y + 4z - 20 = 0.$$

Which of the following straight lines can be an edge of some tetrahedron whose two faces lie on P_1 and P_2 ?

- (A) $\frac{x-1}{0} = \frac{y-1}{0} = \frac{z-1}{5}$
 (B) $\frac{x-6}{-5} = \frac{y}{2} = \frac{z}{3}$
 (C) $\frac{x}{-2} = \frac{y-4}{5} = \frac{z}{4}$
 (D) $\frac{x}{1} = \frac{y-4}{-2} = \frac{z}{3}$

Answer: A, B, D

Q.12 Let S be the reflection of a point Q with respect to the plane given by

$$\vec{r} = -(t+p)\hat{i} + t\hat{j} + (1+p)\hat{k}$$

where t, p are real parameters and $\hat{i}, \hat{j}, \hat{k}$ are the unit vectors along the three positive coordinate axes. If the position vectors of Q and S are $10\hat{i} + 15\hat{j} + 20\hat{k}$ and $\alpha\hat{i} + \beta\hat{j} + \gamma\hat{k}$ respectively, then which of the following is/are TRUE ?

- (A) $3(\alpha + \beta) = -101$
 (B) $3(\beta + \gamma) = -71$
 (C) $3(\gamma + \alpha) = -86$
 (D) $3(\alpha + \beta + \gamma) = -121$

Answer: A, B, C

- Q.13 Consider the parabola $y^2 = 4x$. Let S be the focus of the parabola. A pair of tangents drawn to the parabola from the point $P = (-2, 1)$ meet the parabola at P_1 and P_2 . Let Q_1 and Q_2 be points on the lines SP_1 and SP_2 respectively such that PQ_1 is perpendicular to SP_1 and PQ_2 is perpendicular to SP_2 . Then, which of the following is/are TRUE ?

- (A) $SQ_1 = 2$
 (B) $Q_1Q_2 = \frac{3\sqrt{10}}{5}$
 (C) $PQ_1 = 3$
 (D) $SQ_2 = 1$

Answer: B, C, D

- Q.14 Let $|M|$ denote the determinant of a square matrix M . Let $g: \left[0, \frac{\pi}{2}\right] \rightarrow \mathbb{R}$ be the function defined by

$$g(\theta) = \sqrt{f(\theta) - 1} + \sqrt{f\left(\frac{\pi}{2} - \theta\right) - 1}$$

where

$$f(\theta) = \frac{1}{2} \begin{vmatrix} 1 & \sin \theta & 1 \\ -\sin \theta & 1 & \sin \theta \\ -1 & -\sin \theta & 1 \end{vmatrix} + \begin{vmatrix} \sin \pi & \cos\left(\theta + \frac{\pi}{4}\right) & \tan\left(\theta - \frac{\pi}{4}\right) \\ \sin\left(\theta - \frac{\pi}{4}\right) & -\cos\frac{\pi}{2} & \log_e\left(\frac{4}{\pi}\right) \\ \cot\left(\theta + \frac{\pi}{4}\right) & \log_e\left(\frac{\pi}{4}\right) & \tan \pi \end{vmatrix}.$$

Let $p(x)$ be a quadratic polynomial whose roots are the maximum and minimum values of the function $g(\theta)$, and $p(2) = 2 - \sqrt{2}$. Then, which of the following is/are TRUE ?

- (A) $p\left(\frac{3+\sqrt{2}}{4}\right) < 0$
 (B) $p\left(\frac{1+3\sqrt{2}}{4}\right) > 0$
 (C) $p\left(\frac{5\sqrt{2}-1}{4}\right) > 0$
 (D) $p\left(\frac{5-\sqrt{2}}{4}\right) < 0$

Answer: A, C

SECTION 3 (Maximum Marks: 12)

- This section contains **FOUR (04)** Matching List Sets.
- Each set has **ONE** Multiple Choice Question.
- Each set has **TWO** lists: **List-I** and **List-II**.
- **List-I** has **Four** entries (I), (II), (III) and (IV) and **List-II** has **Five** entries (P), (Q), (R), (S) and (T).
- **FOUR** options are given in each Multiple Choice Question based on **List-I** and **List-II** and **ONLY ONE** of these four options satisfies the condition asked in the Multiple Choice Question.
- Answer to each question will be evaluated according to the following marking scheme:
Full Marks : +3 **ONLY** if the option corresponding to the correct combination is chosen;
Zero Marks : 0 If none of the options is chosen (i.e. the question is unanswered);
Negative Marks : -1 In all other cases.

Q.15 Consider the following lists:

List-I	List-II
(I) $\left\{x \in \left[-\frac{2\pi}{3}, \frac{2\pi}{3}\right]: \cos x + \sin x = 1\right\}$	(P) has two elements
(II) $\left\{x \in \left[-\frac{5\pi}{18}, \frac{5\pi}{18}\right]: \sqrt{3} \tan 3x = 1\right\}$	(Q) has three elements
(III) $\left\{x \in \left[-\frac{6\pi}{5}, \frac{6\pi}{5}\right]: 2 \cos(2x) = \sqrt{3}\right\}$	(R) has four elements
(IV) $\left\{x \in \left[-\frac{7\pi}{4}, \frac{7\pi}{4}\right]: \sin x - \cos x = 1\right\}$	(S) has five elements
	(T) has six elements

The correct option is:

- (A) (I) \rightarrow (P); (II) \rightarrow (S); (III) \rightarrow (P); (IV) \rightarrow (S)
 (B) (I) \rightarrow (P); (II) \rightarrow (P); (III) \rightarrow (T); (IV) \rightarrow (R)
 (C) (I) \rightarrow (Q); (II) \rightarrow (P); (III) \rightarrow (T); (IV) \rightarrow (S)
 (D) (I) \rightarrow (Q); (II) \rightarrow (S); (III) \rightarrow (P); (IV) \rightarrow (R)

Answer: B

- Q.16 Two players, P_1 and P_2 , play a game against each other. In every round of the game, each player rolls a fair die once, where the six faces of the die have six distinct numbers. Let x and y denote the readings on the die rolled by P_1 and P_2 , respectively. If $x > y$, then P_1 scores 5 points and P_2 scores 0 point. If $x = y$, then each player scores 2 points. If $x < y$, then P_1 scores 0 point and P_2 scores 5 points. Let X_i and Y_i be the total scores of P_1 and P_2 , respectively, after playing the i^{th} round.

List-I**List-II**

- | | |
|--|-----------------------|
| (I) Probability of $(X_2 \geq Y_2)$ is | (P) $\frac{3}{8}$ |
| (II) Probability of $(X_2 > Y_2)$ is | (Q) $\frac{11}{16}$ |
| (III) Probability of $(X_3 = Y_3)$ is | (R) $\frac{5}{16}$ |
| (IV) Probability of $(X_3 > Y_3)$ is | (S) $\frac{355}{864}$ |
| | (T) $\frac{77}{432}$ |

The correct option is:

- (A) (I) \rightarrow (Q); (II) \rightarrow (R); (III) \rightarrow (T); (IV) \rightarrow (S)
 (B) (I) \rightarrow (Q); (II) \rightarrow (R); (III) \rightarrow (T); (IV) \rightarrow (T)
 (C) (I) \rightarrow (P); (II) \rightarrow (R); (III) \rightarrow (Q); (IV) \rightarrow (S)
 (D) (I) \rightarrow (P); (II) \rightarrow (R); (III) \rightarrow (Q); (IV) \rightarrow (T)

Answer: A

Q.17 Let p, q, r be nonzero real numbers that are, respectively, the 10^{th} , 100^{th} and 1000^{th} terms of a harmonic progression. Consider the system of linear equations

$$\begin{aligned}x + y + z &= 1 \\10x + 100y + 1000z &= 0 \\qr x + pr y + pq z &= 0 .\end{aligned}$$

List-I

- (I) If $\frac{q}{r} = 10$, then the system of linear equations has
- (II) If $\frac{p}{r} \neq 100$, then the system of linear equations has
- (III) If $\frac{p}{q} \neq 10$, then the system of linear equations has
- (IV) If $\frac{p}{q} = 10$, then the system of linear equations has

List-II

- (P) $x = 0, y = \frac{10}{9}, z = -\frac{1}{9}$ as a solution
- (Q) $x = \frac{10}{9}, y = -\frac{1}{9}, z = 0$ as a solution
- (R) infinitely many solutions
- (S) no solution
- (T) at least one solution

The correct option is:

- (A) (I) \rightarrow (T); (II) \rightarrow (R); (III) \rightarrow (S); (IV) \rightarrow (T)
- (B) (I) \rightarrow (Q); (II) \rightarrow (S); (III) \rightarrow (S); (IV) \rightarrow (R)
- (C) (I) \rightarrow (Q); (II) \rightarrow (R); (III) \rightarrow (P); (IV) \rightarrow (R)
- (D) (I) \rightarrow (T); (II) \rightarrow (S); (III) \rightarrow (P); (IV) \rightarrow (T)

Answer: B

Q.18 Consider the ellipse

$$\frac{x^2}{4} + \frac{y^2}{3} = 1.$$

Let $H(\alpha, 0)$, $0 < \alpha < 2$, be a point. A straight line drawn through H parallel to the y -axis crosses the ellipse and its auxiliary circle at points E and F respectively, in the first quadrant. The tangent to the ellipse at the point E intersects the positive x -axis at a point G . Suppose the straight line joining F and the origin makes an angle ϕ with the positive x -axis.

List-I

- (I) If $\phi = \frac{\pi}{4}$, then the area of the triangle FGH is
- (II) If $\phi = \frac{\pi}{3}$, then the area of the triangle FGH is
- (III) If $\phi = \frac{\pi}{6}$, then the area of the triangle FGH is
- (IV) If $\phi = \frac{\pi}{12}$, then the area of the triangle FGH is

List-II

- (P) $\frac{(\sqrt{3}-1)^4}{8}$
- (Q) 1
- (R) $\frac{3}{4}$
- (S) $\frac{1}{2\sqrt{3}}$
- (T) $\frac{3\sqrt{3}}{2}$

The correct option is:

- (A) (I) \rightarrow (R); (II) \rightarrow (S); (III) \rightarrow (Q); (IV) \rightarrow (P)
- (B) (I) \rightarrow (R); (II) \rightarrow (T); (III) \rightarrow (S); (IV) \rightarrow (P)
- (C) (I) \rightarrow (Q); (II) \rightarrow (T); (III) \rightarrow (S); (IV) \rightarrow (P)
- (D) (I) \rightarrow (Q); (II) \rightarrow (S); (III) \rightarrow (Q); (IV) \rightarrow (P)

Answer: C

END OF THE QUESTION PAPER

SECTION 1

- This section contains **EIGHT (08)** questions.
- The answer to each question is a **NUMERICAL VALUE**.
- For each question, enter the correct numerical value of the answer using the mouse and the on-screen virtual numeric keypad in the place designated to enter the answer. If the numerical value has more than two decimal places, **truncate/round-off** the value to **TWO** decimal places.
- Answer to each question will be evaluated according to the following marking scheme:
Full Marks : +3 **ONLY** if the correct numerical value is entered;
Zero Marks : 0 In all other cases.

Q.1 Two spherical stars A and B have densities ρ_A and ρ_B , respectively. A and B have the same radius, and their masses M_A and M_B are related by $M_B = 2M_A$. Due to an interaction process, star A loses some of its mass, so that its radius is halved, while its spherical shape is retained, and its density remains ρ_A . The entire mass lost by A is deposited as a thick spherical shell on B with the density of the shell being ρ_A . If v_A and v_B are the escape velocities from A and B after the interaction process, the ratio $\frac{v_B}{v_A} = \sqrt{\frac{10n}{15^{1/3}}}$. The value of n is 2.3. **Range (2.2 - 2.4)**

Q.2 The minimum kinetic energy needed by an alpha particle to cause the nuclear reaction ${}^{16}_7\text{N} + {}^4_2\text{He} \rightarrow {}^1_1\text{H} + {}^{19}_8\text{O}$ in a laboratory frame is n (in MeV). Assume that ${}^{16}_7\text{N}$ is at rest in the laboratory frame. The masses of ${}^{16}_7\text{N}$, ${}^4_2\text{He}$, ${}^1_1\text{H}$ and ${}^{19}_8\text{O}$ can be taken to be $16.006 u$, $4.003 u$, $1.008 u$ and $19.003 u$, respectively, where $1 u = 930 \text{ MeV}c^{-2}$. The value of n is 2.33. **Range (2.30 - 2.35)**

Q.3 In the following circuit $C_1 = 12 \mu\text{F}$, $C_2 = C_3 = 4 \mu\text{F}$ and $C_4 = C_5 = 2 \mu\text{F}$. The charge stored in C_3 is 8 μC . **Range (7.9 - 8.1)**

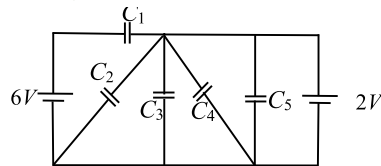

Q.4 A rod of length 2 cm makes an angle $\frac{2\pi}{3} \text{ rad}$ with the principal axis of a thin convex lens. The lens has a focal length of 10 cm and is placed at a distance of $\frac{40}{3} \text{ cm}$ from the object as shown in the figure. The height of the image is $\frac{30\sqrt{3}}{13} \text{ cm}$ and the angle made by it with respect to the principal axis is $\alpha \text{ rad}$. The value of α is $\frac{\pi}{n} \text{ rad}$, where n is 6. **Range (5.95 - 6.05)**

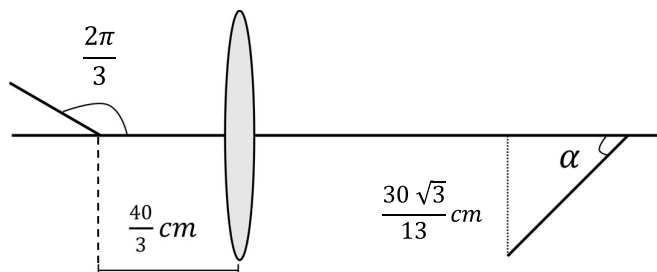

- Q.5 At time $t = 0$, a disk of radius 1 m starts to roll without slipping on a horizontal plane with an angular acceleration of $\alpha = \frac{2}{3}\text{ rad s}^{-2}$. A small stone is stuck to the disk. At $t = 0$, it is at the contact point of the disk and the plane. Later, at time $t = \sqrt{\pi}\text{ s}$, the stone detaches itself and flies off tangentially from the disk. The maximum height (in m) reached by the stone measured from the plane is $\frac{1}{2} + \frac{x}{10}$. The value of x is 0.52. [Take $g = 10\text{ m s}^{-2}$.] **Range (0.48 - 0.56)**

- Q.6 A solid sphere of mass 1 kg and radius 1 m rolls without slipping on a fixed inclined plane with an angle of inclination $\theta = 30^\circ$ from the horizontal. Two forces of magnitude 1 N each, parallel to the incline, act on the sphere, both at distance $r = 0.5\text{ m}$ from the center of the sphere, as shown in the figure. The acceleration of the sphere down the plane is 2.86 ms^{-2} . (Take $g = 10\text{ m s}^{-2}$.)
Range (2.80 - 2.92)

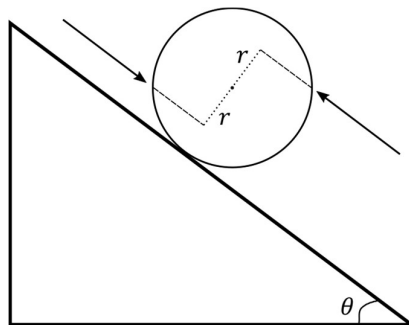

- Q.7 Consider an LC circuit, with inductance $L = 0.1\text{ H}$ and capacitance $C = 10^{-3}\text{ F}$, kept on a plane. The area of the circuit is 1 m^2 . It is placed in a constant magnetic field of strength B_0 which is perpendicular to the plane of the circuit. At time $t = 0$, the magnetic field strength starts increasing linearly as $B = B_0 + \beta t$ with $\beta = 0.04\text{ Ts}^{-1}$. The maximum magnitude of the current in the circuit is 4 mA . **Range (3.98 - 4.02)**
- Q.8 A projectile is fired from horizontal ground with speed v and projection angle θ . When the acceleration due to gravity is g , the range of the projectile is d . If at the highest point in its trajectory, the projectile enters a different region where the effective acceleration due to gravity is $g' = \frac{g}{0.81}$, then the new range is $d' = nd$. The value of n is 0.95. **Range (0.93 - 0.97)**

SECTION 2 (Maximum Marks: 24)

- This section contains **SIX (06)** questions.
- Each question has **FOUR** options (A), (B), (C) and (D). **ONE OR MORE THAN ONE** of these four option(s) is(are) correct answer(s).
- For each question, choose the option(s) corresponding to (all) the correct answer(s).
- Answer to each question will be evaluated according to the following marking scheme:

Full Marks : +4 **ONLY** if (all) the correct option(s) is(are) chosen;

Partial Marks : +3 If all the four options are correct but **ONLY** three options are chosen;

Partial Marks : +2 If three or more options are correct but **ONLY** two options are chosen, both of which are correct;

Partial Marks : +1 If two or more options are correct but **ONLY** one option is chosen and it is a correct option;

Zero Marks : 0 If none of the options is chosen (i.e. the question is unanswered);

Negative Marks : -2 In all other cases.

- Q.9 A medium having dielectric constant $K > 1$ fills the space between the plates of a parallel plate capacitor. The plates have large area, and the distance between them is d . The capacitor is connected to a battery of voltage V , as shown in Figure (a). Now, both the plates are moved by a distance of $\frac{d}{2}$ from their original positions, as shown in Figure (b).

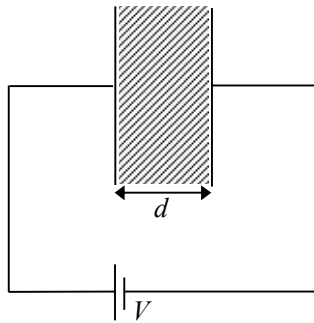

Figure (a)

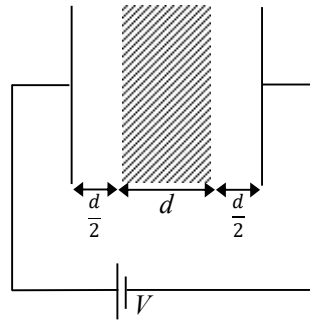

Figure (b)

In the process of going from the configuration depicted in Figure (a) to that in Figure (b), which of the following statement(s) is(are) correct?

- (A) The electric field inside the dielectric material is reduced by a factor of $2K$.
 (B) The capacitance is decreased by a factor of $\frac{1}{K+1}$.
 (C) The voltage between the capacitor plates is increased by a factor of $(K + 1)$.
 (D) The work done in the process **DOES NOT** depend on the presence of the dielectric material.

Answer: B

- Q.10 The figure shows a circuit having eight resistances of $1\ \Omega$ each, labelled R_1 to R_8 , and two ideal batteries with voltages $\mathcal{E}_1 = 12\ V$ and $\mathcal{E}_2 = 6\ V$.

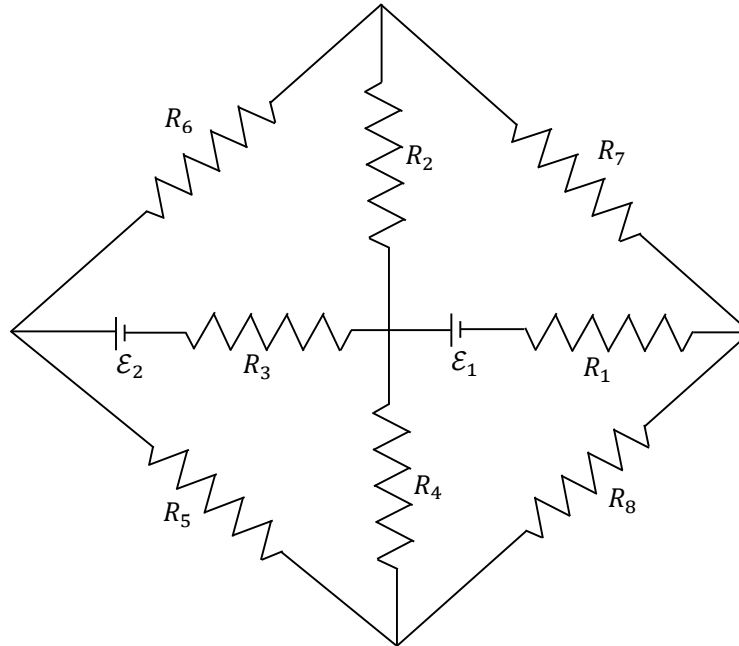

Which of the following statement(s) is(are) correct?

- (A) The magnitude of current flowing through R_1 is $7.2\ A$.
- (B) The magnitude of current flowing through R_2 is $1.2\ A$.
- (C) The magnitude of current flowing through R_3 is $4.8\ A$.
- (D) The magnitude of current flowing through R_5 is $2.4\ A$.

Answer: A, B, C, D

- Q.11 An ideal gas of density $\rho = 0.2 \text{ kg m}^{-3}$ enters a chimney of height h at the rate of $\alpha = 0.8 \text{ kg s}^{-1}$ from its lower end, and escapes through the upper end as shown in the figure. The cross-sectional area of the lower end is $A_1 = 0.1 \text{ m}^2$ and the upper end is $A_2 = 0.4 \text{ m}^2$. The pressure and the temperature of the gas at the lower end are 600 Pa and 300 K , respectively, while its temperature at the upper end is 150 K . The chimney is heat insulated so that the gas undergoes adiabatic expansion. Take $g = 10 \text{ m s}^{-2}$ and the ratio of specific heats of the gas $\gamma = 2$. Ignore atmospheric pressure.

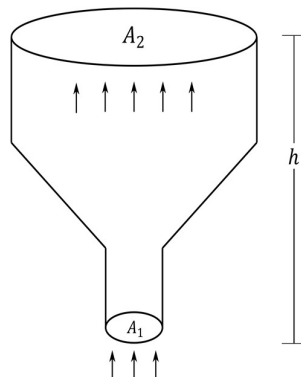

Which of the following statement(s) is(are) correct?

- (A) The pressure of the gas at the upper end of the chimney is 300 Pa .
 (B) The velocity of the gas at the lower end of the chimney is 40 m s^{-1} and at the upper end is 20 m s^{-1} .
 (C) The height of the chimney is 590 m .
 (D) The density of the gas at the upper end is 0.05 kg m^{-3} .

Answer: B

- Q.12 Three plane mirrors form an equilateral triangle with each side of length L . There is a small hole at a distance $l > 0$ from one of the corners as shown in the figure. A ray of light is passed through the hole at an angle θ and can only come out through the same hole. The cross section of the mirror configuration and the ray of light lie on the same plane.

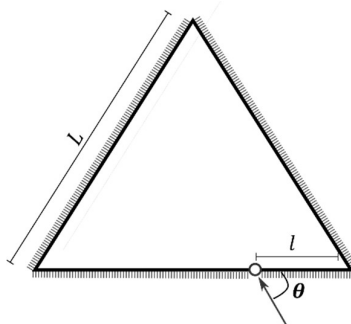

Which of the following statement(s) is(are) correct?

- (A) The ray of light will come out for $\theta = 30^\circ$, for $0 < l < L$.
 (B) There is an angle for $l = \frac{L}{2}$ at which the ray of light will come out after two reflections.
 (C) The ray of light will **NEVER** come out for $\theta = 60^\circ$, and $l = \frac{L}{3}$.
 (D) The ray of light will come out for $\theta = 60^\circ$, and $0 < l < \frac{L}{2}$ after six reflections.

Answer: A, B

- Q.13 Six charges are placed around a regular hexagon of side length a as shown in the figure. Five of them have charge q , and the remaining one has charge x . The perpendicular from each charge to the nearest hexagon side passes through the center O of the hexagon and is bisected by the side.

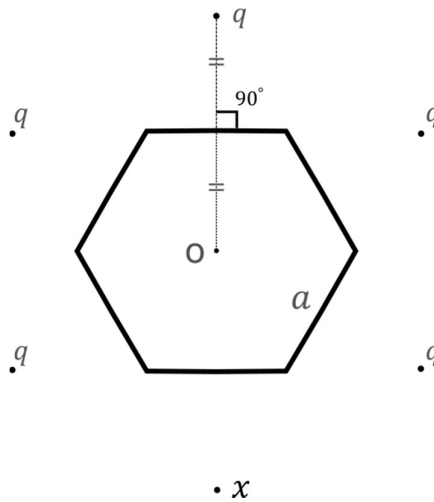

Which of the following statement(s) is(are) correct in SI units?

- (A) When $x = q$, the magnitude of the electric field at O is zero.
 (B) When $x = -q$, the magnitude of the electric field at O is $\frac{q}{6\pi\epsilon_0 a^2}$.
 (C) When $x = 2q$, the potential at O is $\frac{7q}{4\sqrt{3}\pi\epsilon_0 a}$.
 (D) When $x = -3q$, the potential at O is $-\frac{3q}{4\sqrt{3}\pi\epsilon_0 a}$.

Answer: A, B, C

- Q.14 The binding energy of nucleons in a nucleus can be affected by the pairwise Coulomb repulsion. Assume that all nucleons are uniformly distributed inside the nucleus. Let the binding energy of a proton be E_b^p and the binding energy of a neutron be E_b^n in the nucleus.

Which of the following statement(s) is(are) correct?

- (A) $E_b^p - E_b^n$ is proportional to $Z(Z - 1)$ where Z is the atomic number of the nucleus.
 (B) $E_b^p - E_b^n$ is proportional to $A^{-\frac{1}{3}}$ where A is the mass number of the nucleus.
 (C) $E_b^p - E_b^n$ is positive.
 (D) E_b^p increases if the nucleus undergoes a beta decay emitting a positron.

Answer: A, B, D

SECTION 3

- This section contains **FOUR (04)** Matching List Sets.
- Each set has **ONE** Multiple Choice Question.
- Each set has **TWO** lists: **List-I** and **List-II**.
- **List-I** has **Four** entries (I), (II), (III) and (IV) and **List-II** has **Five** entries (P), (Q), (R), (S) and (T).
- **FOUR** options are given in each Multiple Choice Question based on **List-I** and **List-II** and **ONLY ONE** of these four options satisfies the condition asked in the Multiple Choice Question.
- Answer to each question will be evaluated according to the following marking scheme:
Full Marks : +3 **ONLY** if the option corresponding to the correct combination is chosen;
Zero Marks : 0 If none of the options is chosen (i.e. the question is unanswered);
Negative Marks : -1 In all other cases.

- Q.15 A small circular loop of area A and resistance R is fixed on a horizontal xy -plane with the center of the loop always on the axis \hat{n} of a long solenoid. The solenoid has m turns per unit length and carries current I counterclockwise as shown in the figure. The magnetic field due to the solenoid is in \hat{n} direction. List-I gives time dependences of \hat{n} in terms of a constant angular frequency ω . List-II gives the torques experienced by the circular loop at time $t = \frac{\pi}{6\omega}$.

$$\text{Let } \alpha = \frac{A^2 \mu_0^2 m^2 I^2 \omega}{2R}.$$

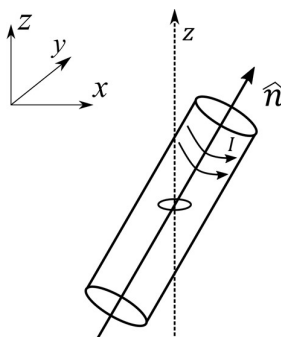

Question dropped
Marks for All

List-I

- (I) $\frac{1}{\sqrt{2}}(\sin \omega t \hat{j} + \cos \omega t \hat{k})$
 (II) $\frac{1}{\sqrt{2}}(\sin \omega t \hat{i} + \cos \omega t \hat{j})$
 (III) $\frac{1}{\sqrt{2}}(\sin \omega t \hat{i} + \cos \omega t \hat{k})$
 (IV) $\frac{1}{\sqrt{2}}(\cos \omega t \hat{j} + \sin \omega t \hat{k})$

List-II

- (P) 0
 (Q) $-\frac{\alpha}{4} \hat{i}$
 (R) $\frac{3\alpha}{4} \hat{i}$
 (S) $\frac{\alpha}{4} \hat{j}$
 (T) $-\frac{3\alpha}{4} \hat{i}$

Which one of the following options is correct?

- (A) I \rightarrow Q, II \rightarrow P, III \rightarrow S, IV \rightarrow T
 (B) I \rightarrow S, II \rightarrow T, III \rightarrow Q, IV \rightarrow P
 (C) I \rightarrow Q, II \rightarrow P, III \rightarrow S, IV \rightarrow R
 (D) I \rightarrow T, II \rightarrow Q, III \rightarrow P, IV \rightarrow R

Q.16 List I describes four systems, each with two particles *A* and *B* in relative motion as shown in figures. List II gives possible magnitudes of their relative velocities (in $m s^{-1}$) at time $t = \frac{\pi}{3} s$.

List-I

(I) *A* and *B* are moving on a horizontal circle of radius $1 m$ with uniform angular speed $\omega = 1 rad s^{-1}$. The initial angular positions of *A* and *B* at time $t = 0$ are $\theta = 0$ and $\theta = \frac{\pi}{2}$, respectively.

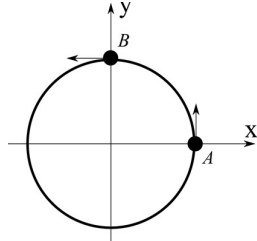

(II) Projectiles *A* and *B* are fired (in the same vertical plane) at $t = 0$ and $t = 0.1 s$ respectively, with the same speed $v = \frac{5\pi}{\sqrt{2}} m s^{-1}$ and at 45° from the horizontal plane. The initial separation between *A* and *B* is large enough so that they do not collide. ($g = 10 m s^{-2}$).

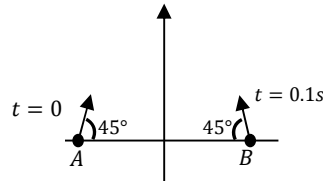

(III) Two harmonic oscillators *A* and *B* moving in the *x* direction according to $x_A = x_0 \sin \frac{t}{t_0}$ and $x_B = x_0 \sin \left(\frac{t}{t_0} + \frac{\pi}{2} \right)$ respectively, starting from $t = 0$. Take $x_0 = 1 m, t_0 = 1 s$.

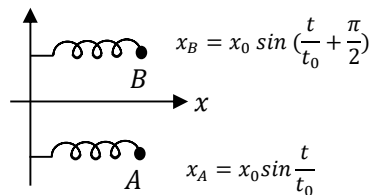

(IV) Particle *A* is rotating in a horizontal circular path of radius $1 m$ on the *xy* plane, with constant angular speed $\omega = 1 rad s^{-1}$. Particle *B* is moving up at a constant speed $3 m s^{-1}$ in the vertical direction as shown in the figure. (Ignore gravity.)

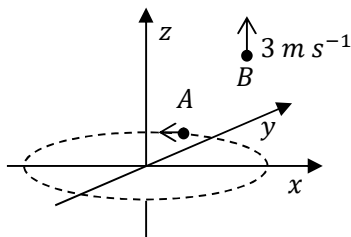

List-II

(P) $\frac{\sqrt{3}+1}{2}$

(Q) $\frac{(\sqrt{3}-1)}{\sqrt{2}}$

(R) $\sqrt{10}$

(S) $\sqrt{2}$

(T) $\sqrt{25\pi^2 + 1}$

Which one of the following options is correct?

- (A) I \rightarrow R, II \rightarrow T, III \rightarrow P, IV \rightarrow S
- (B) I \rightarrow S, II \rightarrow P, III \rightarrow Q, IV \rightarrow R
- (C) I \rightarrow S, II \rightarrow T, III \rightarrow P, IV \rightarrow R
- (D) I \rightarrow T, II \rightarrow P, III \rightarrow R, IV \rightarrow S

Answer: C

- Q.17 List I describes thermodynamic processes in four different systems. List II gives the magnitudes (either exactly or as a close approximation) of possible changes in the internal energy of the system due to the process.

List-I

(I) 10^{-3} kg of water at 100°C is converted to steam at the same temperature, at a pressure of 10^5 Pa. The volume of the system changes from 10^{-6} m³ to 10^{-3} m³ in the process. Latent heat of water = 2250 kJ/kg.

(II) 0.2 moles of a rigid diatomic ideal gas with volume V at temperature 500 K undergoes an isobaric expansion to volume $3V$. Assume $R = 8.0$ J mol⁻¹K⁻¹.

(III) One mole of a monatomic ideal gas is compressed adiabatically from volume $V = \frac{1}{3}$ m³ and pressure 2 kPa to volume $\frac{V}{8}$.

(IV) Three moles of a diatomic ideal gas whose molecules can vibrate, is given 9 kJ of heat and undergoes isobaric expansion.

List-II

(P) 2 kJ

(Q) 7 kJ

(R) 4 kJ

(S) 5 kJ

(T) 3 kJ

Which one of the following options is correct?

- (A) I \rightarrow T, II \rightarrow R, III \rightarrow S, IV \rightarrow Q,
 (B) I \rightarrow S, II \rightarrow P, III \rightarrow T, IV \rightarrow P,
 (C) I \rightarrow P, II \rightarrow R, III \rightarrow T, IV \rightarrow Q.
 (D) I \rightarrow Q, II \rightarrow R, III \rightarrow S, IV \rightarrow T,

Answer: C

- Q.18 List I contains four combinations of two lenses (1 and 2) whose focal lengths (in cm) are indicated in the figures. In all cases, the object is placed 20 cm from the first lens on the left, and the distance between the two lenses is 5 cm . List II contains the positions of the final images.

List-I

List-II

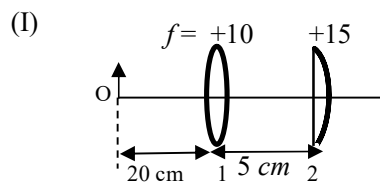

(P) Final image is formed at 7.5 cm on the right side of lens 2.

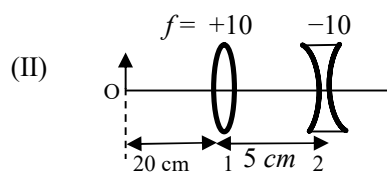

(Q) Final image is formed at 60.0 cm on the right side of lens 2.

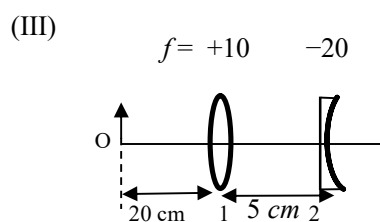

(R) Final image is formed at 30.0 cm on the left side of lens 2.

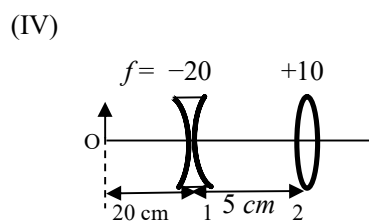

(S) Final image is formed at 6.0 cm on the right side of lens 2.

(T) Final image is formed at 30.0 cm on the right side of lens 2.

Which one of the following options is correct?

- (A) (I) \rightarrow P; (II) \rightarrow R; (III) \rightarrow Q; (IV) \rightarrow T
 (B) (I) \rightarrow Q; (II) \rightarrow P; (III) \rightarrow T; (IV) \rightarrow S
 (C) (I) \rightarrow P; (II) \rightarrow T; (III) \rightarrow R; (IV) \rightarrow Q
 (D) (I) \rightarrow T; (II) \rightarrow S; (III) \rightarrow Q; (IV) \rightarrow R

Answer: A

END OF THE QUESTION PAPER

SECTION 1 (Maximum Marks: 24)

- This section contains **EIGHT (08)** questions.
- The answer to each question is a **NUMERICAL VALUE**.
- For each question, enter the correct numerical value of the answer using the mouse and the on-screen virtual numeric keypad in the place designated to enter the answer. If the numerical value has more than two decimal places, **truncate/round-off** the value to **TWO** decimal places.
- Answer to each question will be evaluated according to the following marking scheme:
Full Marks : +3 **ONLY** if the correct numerical value is entered;
Zero Marks : 0 In all other cases.

Q.1 2 mol of $\text{Hg}(g)$ is combusted in a fixed volume bomb calorimeter with excess of O_2 at 298 K and 1 atm into $\text{HgO}(s)$. During the reaction, temperature increases from 298.0 K to 312.8 K. If heat capacity of the bomb calorimeter and enthalpy of formation of $\text{Hg}(g)$ are 20.00 kJ K^{-1} and $61.32 \text{ kJ mol}^{-1}$ at 298 K, respectively, the calculated standard molar enthalpy of formation of $\text{HgO}(s)$ at 298 K is X kJ mol^{-1} . The value of |X| is 90.39. **Range (89.00-91.00)**

[Given: Gas constant $R = 8.3 \text{ J K}^{-1} \text{ mol}^{-1}$]

Q.2 The reduction potential (E^0 , in V) of $\text{MnO}_4^- (\text{aq})/\text{Mn}(s)$ is 0.77. **Range (0.74-0.80)**

[Given: $E^0_{(\text{MnO}_4^- (\text{aq})/\text{MnO}_2 (\text{s}))} = 1.68 \text{ V}$; $E^0_{(\text{MnO}_2 (\text{s})/\text{Mn}^{2+} (\text{aq}))} = 1.21 \text{ V}$; $E^0_{(\text{Mn}^{2+} (\text{aq})/\text{Mn}(s))} = -1.03 \text{ V}$]

Q.3 A solution is prepared by mixing 0.01 mol each of H_2CO_3 , NaHCO_3 , Na_2CO_3 , and NaOH in 100 mL of water. pH of the resulting solution is 10.02. **Range (10.00-10.04)**

[Given: $\text{pK}_{\text{a}1}$ and $\text{pK}_{\text{a}2}$ of H_2CO_3 are 6.37 and 10.32, respectively; $\log 2 = 0.30$]

Q.4 The treatment of an aqueous solution of 3.74 g of $\text{Cu}(\text{NO}_3)_2$ with excess KI results in a brown solution along with the formation of a precipitate. Passing H_2S through this brown solution gives another precipitate **X**. The amount of **X** (in g) is 0.32. **Range (0.31-0.33)**

[Given: Atomic mass of $\text{H} = 1$, $\text{N} = 14$, $\text{O} = 16$, $\text{S} = 32$, $\text{K} = 39$, $\text{Cu} = 63$, $\text{I} = 127$]

Q.5 Dissolving 1.24 g of white phosphorous in boiling NaOH solution in an inert atmosphere gives a gas **Q**. The amount of CuSO_4 (in g) required to completely consume the gas **Q** is 2.39. **Range (2.37-2.41)**

[Given: Atomic mass of $\text{H} = 1$, $\text{O} = 16$, $\text{Na} = 23$, $\text{P} = 31$, $\text{S} = 32$, $\text{Cu} = 63$]

Q.6 Consider the following reaction.

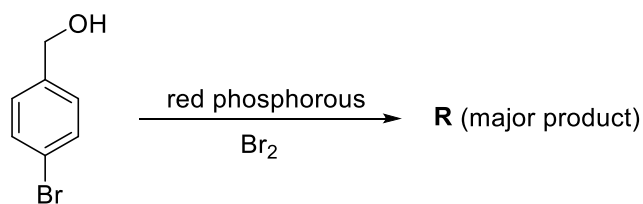

On estimation of bromine in 1.00 g of **R** using Carius method, the amount of AgBr formed (in g) is 1.50. **Range (1.49-1.51)**

[Given: Atomic mass of H = 1, C = 12, O = 16, P = 31, Br = 80, Ag = 108]

Q.7 The weight percentage of hydrogen in **Q**, formed in the following reaction sequence, is 1.31.

Range (1.30-1.32)

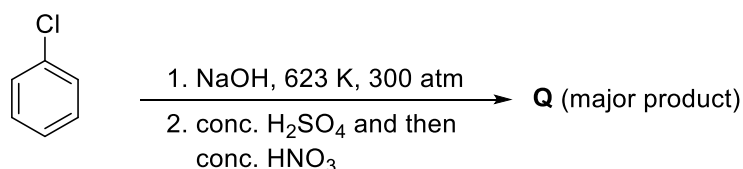

[Given: Atomic mass of H = 1, C = 12, N = 14, O = 16, S = 32, Cl = 35]

Q.8 If the reaction sequence given below is carried out with 15 moles of acetylene, the amount of the product **D** formed (in g) is 136.00. **Range (135.80-136.20)**

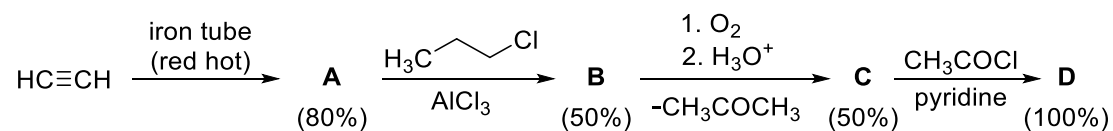

The yields of **A**, **B**, **C** and **D** are given in parentheses.

[Given: Atomic mass of H = 1, C = 12, O = 16, Cl = 35]

SECTION 2 (Maximum Marks: 24)

- This section contains **SIX (06)** questions.
- Each question has **FOUR** options (A), (B), (C) and (D). **ONE OR MORE THAN ONE** of these four option(s) is(are) correct answer(s).
- For each question, choose the option(s) corresponding to (all) the correct answer(s).
- Answer to each question will be evaluated according to the following marking scheme:
 - Full Marks* : +4 **ONLY** if (all) the correct option(s) is(are) chosen;
 - Partial Marks* : +3 If all the four options are correct but **ONLY** three options are chosen;
 - Partial Marks* : +2 If three or more options are correct but **ONLY** two options are chosen, both of which are correct;
 - Partial Marks* : +1 If two or more options are correct but **ONLY** one option is chosen and it is a correct option;
 - Zero Marks* : 0 If none of the options is chosen (i.e. the question is unanswered);
 - Negative Marks* : -2 In all other cases.

Q.9 For diatomic molecules, the correct statement(s) about the molecular orbitals formed by the overlap of two $2p_z$ orbitals is(are)

- (A) σ orbital has a total of two nodal planes.
- (B) σ^* orbital has one node in the xz -plane containing the molecular axis.
- (C) π orbital has one node in the plane which is perpendicular to the molecular axis and goes through the center of the molecule.
- (D) π^* orbital has one node in the xy -plane containing the molecular axis.

Answer: A, D

Q.10 The correct option(s) related to adsorption processes is(are)

- (A) Chemisorption results in a unimolecular layer.
- (B) The enthalpy change during physisorption is in the range of 100 to 140 kJ mol⁻¹.
- (C) Chemisorption is an endothermic process.
- (D) Lowering the temperature favors physisorption processes.

Answer: A, D

Q.11 The electrochemical extraction of aluminum from bauxite ore involves

- (A) the reaction of Al_2O_3 with coke (C) at a temperature $> 2500^\circ\text{C}$.
- (B) the neutralization of aluminate solution by passing CO_2 gas to precipitate hydrated alumina ($\text{Al}_2\text{O}_3 \cdot 3\text{H}_2\text{O}$).
- (C) the dissolution of Al_2O_3 in hot aqueous NaOH .
- (D) the electrolysis of Al_2O_3 mixed with Na_3AlF_6 to give Al and CO_2 .

Answer: B, C, D

Q.12 The treatment of galena with HNO_3 produces a gas that is

- (A) paramagnetic
- (B) bent in geometry
- (C) an acidic oxide
- (D) colorless

Answer: A, D

Q.13 Considering the reaction sequence given below, the correct statement(s) is(are)

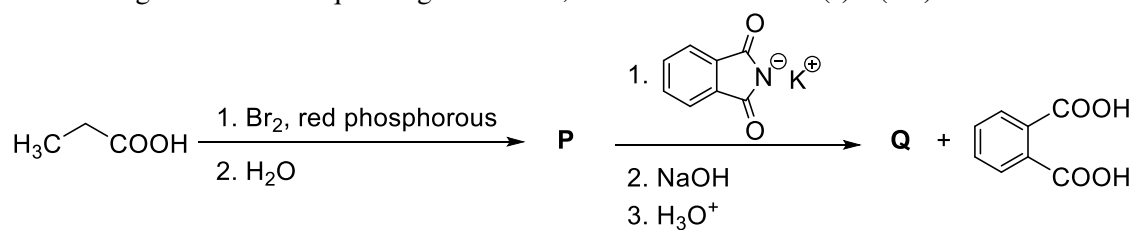

- (A) **P** can be reduced to a primary alcohol using NaBH_4 .
- (B) Treating **P** with conc. NH_4OH solution followed by acidification gives **Q**.
- (C) Treating **Q** with a solution of NaNO_2 in aq. HCl liberates N_2 .
- (D) **P** is more acidic than $\text{CH}_3\text{CH}_2\text{COOH}$.

Answer: B, C, D

Q.14 Considering the following reaction sequence,

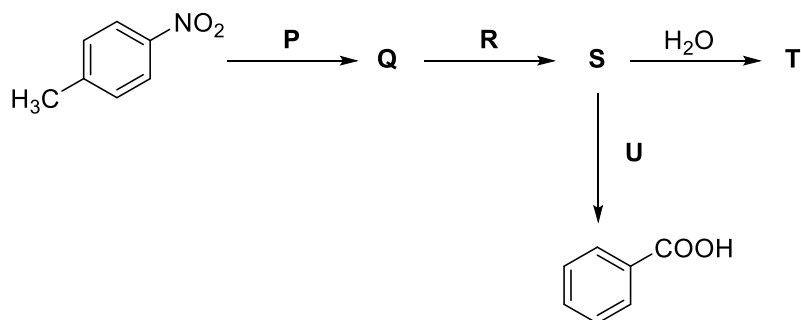

the correct option(s) is(are)

(A)

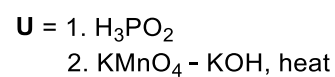
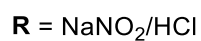
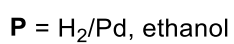

(B)

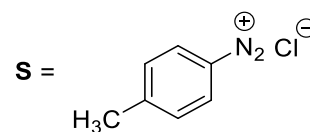
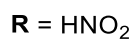

(C)

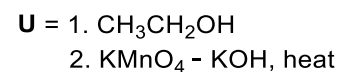
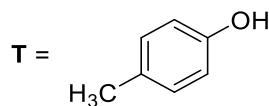
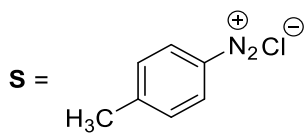

(D)

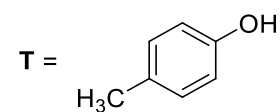
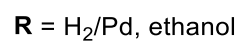
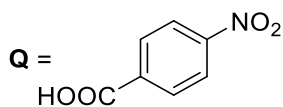

Answer: A, B, C

SECTION 3 (Maximum Marks: 12)

- This section contains **FOUR (04)** Matching List Sets.
- Each set has **ONE** Multiple Choice Question.
- Each set has **TWO** lists: **List-I** and **List-II**.
- **List-I** has **Four** entries (I), (II), (III) and (IV) and **List-II** has **Five** entries (P), (Q), (R), (S) and (T).
- **FOUR** options are given in each Multiple Choice Question based on **List-I** and **List-II** and **ONLY ONE** of these four options satisfies the condition asked in the Multiple Choice Question.
- Answer to each question will be evaluated according to the following marking scheme:
Full Marks : +3 **ONLY** if the option corresponding to the correct combination is chosen;
Zero Marks : 0 If none of the options is chosen (i.e. the question is unanswered);
Negative Marks : -1 In all other cases.

Q.15 Match the rate expressions in LIST-I for the decomposition of X with the corresponding profiles provided in LIST-II. X_s and k are constants having appropriate units.

(I) **LIST-I**

$$\text{rate} = \frac{k[X]}{X_s + [X]}$$
 under all possible initial concentrations of X

(II)

$$\text{rate} = \frac{k[X]}{X_s + [X]}$$
 where initial concentrations of X are much less than X_s

(III)

$$\text{rate} = \frac{k[X]}{X_s + [X]}$$
 where initial concentrations of X are much higher than X_s

(IV)

$$\text{rate} = \frac{k[X]^2}{X_s + [X]}$$
 where initial concentration of X is much higher than X_s

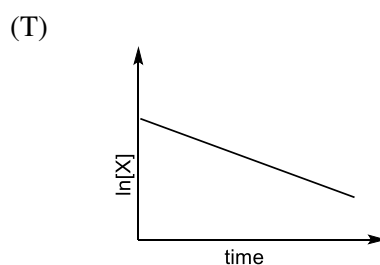
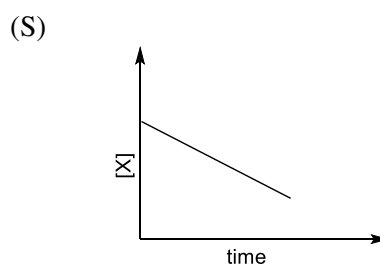
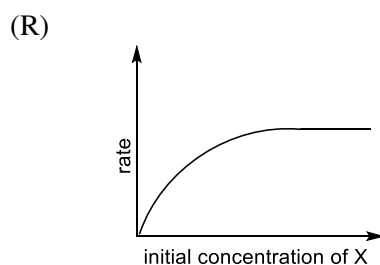
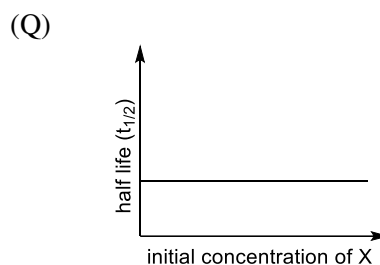
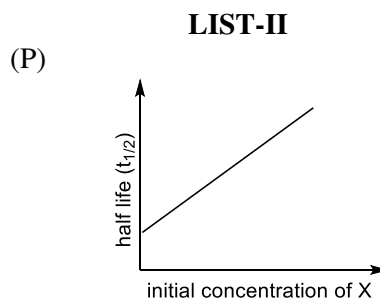

- (A) I → P; II → Q; III → S; IV → T
 (B) I → R; II → S; III → S; IV → T
 (C) I → P; II → Q; III → Q; IV → R
 (D) I → R; II → S; III → Q; IV → R

Answer: A

Q.16 LIST-I contains compounds and LIST-II contains reactions

LIST-I

- (I) H_2O_2
 (II) $\text{Mg}(\text{OH})_2$
 (III) BaCl_2
 (IV) CaCO_3

LIST-II

- (P) $\text{Mg}(\text{HCO}_3)_2 + \text{Ca}(\text{OH})_2 \rightarrow$
 (Q) $\text{BaO}_2 + \text{H}_2\text{SO}_4 \rightarrow$
 (R) $\text{Ca}(\text{OH})_2 + \text{MgCl}_2 \rightarrow$
 (S) $\text{BaO}_2 + \text{HCl} \rightarrow$
 (T) $\text{Ca}(\text{HCO}_3)_2 + \text{Ca}(\text{OH})_2 \rightarrow$

Match each compound in LIST-I with its formation reaction(s) in LIST-II, and choose the correct option

- (A) I \rightarrow Q; II \rightarrow P; III \rightarrow S; IV \rightarrow R
 (B) I \rightarrow T; II \rightarrow P; III \rightarrow Q; IV \rightarrow R
 (C) I \rightarrow T; II \rightarrow R; III \rightarrow Q; IV \rightarrow P
 (D) I \rightarrow Q; II \rightarrow R; III \rightarrow S; IV \rightarrow P

Answer: D

Q.17 LIST-I contains metal species and LIST-II contains their properties.

LIST-I

- (I) $[\text{Cr}(\text{CN})_6]^{4-}$
 (II) $[\text{RuCl}_6]^{2-}$
 (III) $[\text{Cr}(\text{H}_2\text{O})_6]^{2+}$
 (IV) $[\text{Fe}(\text{H}_2\text{O})_6]^{2+}$

LIST-II

- (P) t_{2g} orbitals contain 4 electrons
 (Q) $\mu(\text{spin-only}) = 4.9 \text{ BM}$
 (R) low spin complex ion
 (S) metal ion in 4+ oxidation state
 (T) d^4 species

[Given: Atomic number of Cr = 24, Ru = 44, Fe = 26]

Match each metal species in LIST-I with their properties in LIST-II, and choose the correct option

- (A) I \rightarrow R, T; II \rightarrow P, S; III \rightarrow Q, T; IV \rightarrow P, Q
 (B) I \rightarrow R, S; II \rightarrow P, T; III \rightarrow P, Q; IV \rightarrow Q, T
 (C) I \rightarrow P, R; II \rightarrow R, S; III \rightarrow R, T; IV \rightarrow P, T
 (D) I \rightarrow Q, T; II \rightarrow S, T; III \rightarrow P, T; IV \rightarrow Q, R

Answer: A

Q.18 Match the compounds in LIST-I with the observations in LIST-II, and choose the correct option.

LIST-I

(I) Aniline

(II) *o*-Cresol

(III) Cysteine

(IV) Caprolactam

LIST-II

(P) Sodium fusion extract of the compound on boiling with FeSO_4 , followed by acidification with conc. H_2SO_4 , gives Prussian blue color.

(Q) Sodium fusion extract of the compound on treatment with sodium nitroprusside gives blood red color.

(R) Addition of the compound to a saturated solution of NaHCO_3 results in effervescence.

(S) The compound reacts with bromine water to give a white precipitate.

(T) Treating the compound with neutral FeCl_3 solution produces violet color.

(A) I→P,Q; II→S; III→Q,R; IV→P

(B) I→P; II→R,S; III→R; IV→Q,S

(C) I→Q,S; II→P,T; III→P; IV→S

(D) I→P,S; II→T; III→Q,R; IV→P

Answer: D

END OF THE QUESTION PAPER

SECTION 1 (Maximum marks: 24)

- This section contains **EIGHT (08)** questions.
- The answer to each question is a **SINGLE DIGIT INTEGER ranging from 0 TO 9, BOTH INCLUSIVE**.
- For each question, enter the correct integer corresponding to the answer using the mouse and the on-screen virtual numeric keypad in the place designated to enter the answer.
- Answer to each question will be evaluated according to the following marking scheme:
Full Marks : +3 If **ONLY** the correct integer is entered;
Zero Marks : 0 If the question is unanswered;
Negative Marks : -1 In all other cases.

Q.1 Let α and β be real numbers such that $-\frac{\pi}{4} < \beta < 0 < \alpha < \frac{\pi}{4}$. If $\sin(\alpha + \beta) = \frac{1}{3}$ and $\cos(\alpha - \beta) = \frac{2}{3}$, then the greatest integer less than or equal to

$$\left(\frac{\sin \alpha}{\cos \beta} + \frac{\cos \beta}{\sin \alpha} + \frac{\cos \alpha}{\sin \beta} + \frac{\sin \beta}{\cos \alpha} \right)^2$$

is 1.

Q.2 If $y(x)$ is the solution of the differential equation

$$x dy - (y^2 - 4y) dx = 0 \text{ for } x > 0, \quad y(1) = 2,$$

and the slope of the curve $y = y(x)$ is never zero, then the value of $10 y(\sqrt{2})$ is 8.

Q.3 The greatest integer less than or equal to

$$\int_1^2 \log_2(x^3 + 1) dx + \int_1^{\log_2 9} (2^x - 1)^{\frac{1}{3}} dx$$

is 5.

Q.4 The product of all positive real values of x satisfying the equation

$$x^{(16(\log_5 x)^3 - 68 \log_5 x)} = 5^{-16}$$

is 1.

Q.5 If

$$\beta = \lim_{x \rightarrow 0} \frac{e^{x^3} - (1 - x^3)^{\frac{1}{3}} + ((1 - x^2)^{\frac{1}{2}} - 1) \sin x}{x \sin^2 x},$$

then the value of 6β is 5.

Q.6 Let β be a real number. Consider the matrix

$$A = \begin{pmatrix} \beta & 0 & 1 \\ 2 & 1 & -2 \\ 3 & 1 & -2 \end{pmatrix}.$$

If $A^7 - (\beta - 1)A^6 - \beta A^5$ is a singular matrix, then the value of 9β is 3.

Q.7 Consider the hyperbola

$$\frac{x^2}{100} - \frac{y^2}{64} = 1$$

with foci at S and S_1 , where S lies on the positive x -axis. Let P be a point on the hyperbola, in the first quadrant. Let $\angle SPS_1 = \alpha$, with $\alpha < \frac{\pi}{2}$. The straight line passing through the point S and having the same slope as that of the tangent at P to the hyperbola, intersects the straight line S_1P at P_1 . Let δ be the distance of P from the straight line SP_1 , and $\beta = S_1P$. Then the greatest integer less than or equal to $\frac{\beta\delta}{9} \sin \frac{\alpha}{2}$ is 7.

Q.8 Consider the functions $f, g : \mathbb{R} \rightarrow \mathbb{R}$ defined by

$$f(x) = x^2 + \frac{5}{12} \quad \text{and} \quad g(x) = \begin{cases} 2\left(1 - \frac{4|x|}{3}\right), & |x| \leq \frac{3}{4}, \\ 0, & |x| > \frac{3}{4}. \end{cases}$$

If α is the area of the region

$$\left\{ (x, y) \in \mathbb{R} \times \mathbb{R} : |x| \leq \frac{3}{4}, 0 \leq y \leq \min\{f(x), g(x)\} \right\},$$

then the value of 9α is 6.

SECTION 2 (Maximum marks: 24)

- This section contains **SIX (06)** questions.
- Each question has **FOUR** options (A), (B), (C) and (D). **ONE OR MORE THAN ONE** of these four option(s) is (are) correct answer(s).
- For each question, choose the option(s) corresponding to (all) the correct answer(s).
- Answer to each question will be evaluated according to the following marking scheme:
 - Full Marks* : +4 **ONLY** if (all) the correct option(s) is(are) chosen;
 - Partial Marks* : +3 If all the four options are correct but **ONLY** three options are chosen;
 - Partial Marks* : +2 If three or more options are correct but **ONLY** two options are chosen, both of which are correct;
 - Partial Marks* : +1 If two or more options are correct but **ONLY** one option is chosen and it is a correct option;
 - Zero Marks* : 0 If unanswered;
 - Negative Marks* : -2 In all other cases.

Q.9 Let $PQRS$ be a quadrilateral in a plane, where $QR = 1$, $\angle PQR = \angle QRS = 70^\circ$, $\angle PQS = 15^\circ$ and $\angle PRS = 40^\circ$. If $\angle RPS = \theta^\circ$, $PQ = \alpha$ and $PS = \beta$, then the interval(s) that contain(s) the value of $4\alpha\beta\sin\theta^\circ$ is/are

(A) $(0, \sqrt{2})$

(B) $(1, 2)$

(C) $(\sqrt{2}, 3)$

(D) $(2\sqrt{2}, 3\sqrt{2})$

Answer: A, B

Q.10 Let

$$\alpha = \sum_{k=1}^{\infty} \sin^{2k} \left(\frac{\pi}{6} \right).$$

Let $g : [0, 1] \rightarrow \mathbb{R}$ be the function defined by

$$g(x) = 2^{\alpha x} + 2^{\alpha(1-x)}.$$

Then, which of the following statements is/are TRUE ?

- (A) The minimum value of $g(x)$ is $2^{\frac{7}{6}}$
- (B) The maximum value of $g(x)$ is $1 + 2^{\frac{1}{3}}$
- (C) The function $g(x)$ attains its maximum at more than one point
- (D) The function $g(x)$ attains its minimum at more than one point

Answer: A, B, C

Q.11 Let \bar{z} denote the complex conjugate of a complex number z . If z is a non-zero complex number for which both real and imaginary parts of

$$(\bar{z})^2 + \frac{1}{z^2}$$

are integers, then which of the following is/are possible value(s) of $|z|$?

- (A) $\left(\frac{43+3\sqrt{205}}{2} \right)^{\frac{1}{4}}$
- (B) $\left(\frac{7+\sqrt{33}}{4} \right)^{\frac{1}{4}}$
- (C) $\left(\frac{9+\sqrt{65}}{4} \right)^{\frac{1}{4}}$
- (D) $\left(\frac{7+\sqrt{13}}{6} \right)^{\frac{1}{4}}$

Answer: A

Q.12 Let G be a circle of radius $R > 0$. Let G_1, G_2, \dots, G_n be n circles of equal radius $r > 0$. Suppose each of the n circles G_1, G_2, \dots, G_n touches the circle G externally. Also, for $i = 1, 2, \dots, n-1$, the circle G_i touches G_{i+1} externally, and G_n touches G_1 externally. Then, which of the following statements is/are TRUE ?

- (A) If $n = 4$, then $(\sqrt{2} - 1)r < R$
 (B) If $n = 5$, then $r < R$
 (C) If $n = 8$, then $(\sqrt{2} - 1)r < R$
 (D) If $n = 12$, then $\sqrt{2}(\sqrt{3} + 1)r > R$

Answer: C, D

Q.13 Let \hat{i}, \hat{j} and \hat{k} be the unit vectors along the three positive coordinate axes. Let

$$\begin{aligned}\vec{a} &= 3\hat{i} + \hat{j} - \hat{k}, \\ \vec{b} &= \hat{i} + b_2\hat{j} + b_3\hat{k}, & b_2, b_3 \in \mathbb{R}, \\ \vec{c} &= c_1\hat{i} + c_2\hat{j} + c_3\hat{k}, & c_1, c_2, c_3 \in \mathbb{R}\end{aligned}$$

be three vectors such that $b_2b_3 > 0$, $\vec{a} \cdot \vec{b} = 0$ and

$$\begin{pmatrix} 0 & -c_3 & c_2 \\ c_3 & 0 & -c_1 \\ -c_2 & c_1 & 0 \end{pmatrix} \begin{pmatrix} 1 \\ b_2 \\ b_3 \end{pmatrix} = \begin{pmatrix} 3 - c_1 \\ 1 - c_2 \\ -1 - c_3 \end{pmatrix}.$$

Then, which of the following is/are TRUE ?

- (A) $\vec{a} \cdot \vec{c} = 0$
 (B) $\vec{b} \cdot \vec{c} = 0$
 (C) $|\vec{b}| > \sqrt{10}$
 (D) $|\vec{c}| \leq \sqrt{11}$

Answer: B, C, D

Q.14 For $x \in \mathbb{R}$, let the function $y(x)$ be the solution of the differential equation

$$\frac{dy}{dx} + 12y = \cos\left(\frac{\pi}{12}x\right), \quad y(0) = 0.$$

Then, which of the following statements is/are TRUE ?

- (A) $y(x)$ is an increasing function
- (B) $y(x)$ is a decreasing function
- (C) There exists a real number β such that the line $y = \beta$ intersects the curve $y = y(x)$ at infinitely many points
- (D) $y(x)$ is a periodic function

Answer: C

SECTION 3 (Maximum marks: 12)

- This section contains **FOUR (04)** questions.
- Each question has **FOUR** options (A), (B), (C) and (D). **ONLY ONE** of these four options is the correct answer.
- For each question, choose the option corresponding to the correct answer.
- Answer to each question will be evaluated according to the following marking scheme:
Full Marks : +3 If **ONLY** the correct option is chosen;
Zero Marks : 0 If none of the options is chosen (i.e. the question is unanswered);
Negative Marks : -1 In all other cases.

Q.15 Consider 4 boxes, where each box contains 3 red balls and 2 blue balls. Assume that all 20 balls are distinct. In how many different ways can 10 balls be chosen from these 4 boxes so that from each box at least one red ball and one blue ball are chosen ?

- (A) 21816 (B) 85536 (C) 12096 (D) 156816

Answer: A

Q.16 If $M = \begin{pmatrix} \frac{5}{2} & \frac{3}{2} \\ -\frac{3}{2} & -\frac{1}{2} \end{pmatrix}$, then which of the following matrices is equal to M^{2022} ?

- (A) $\begin{pmatrix} 3034 & 3033 \\ -3033 & -3032 \end{pmatrix}$
- (B) $\begin{pmatrix} 3034 & -3033 \\ 3033 & -3032 \end{pmatrix}$
- (C) $\begin{pmatrix} 3033 & 3032 \\ -3032 & -3031 \end{pmatrix}$
- (D) $\begin{pmatrix} 3032 & 3031 \\ -3031 & -3030 \end{pmatrix}$

Answer: A

Q.17 Suppose that

Box-I contains 8 red, 3 blue and 5 green balls,
 Box-II contains 24 red, 9 blue and 15 green balls,
 Box-III contains 1 blue, 12 green and 3 yellow balls,
 Box-IV contains 10 green, 16 orange and 6 white balls.

A ball is chosen randomly from Box-I; call this ball b . If b is red then a ball is chosen randomly from Box-II, if b is blue then a ball is chosen randomly from Box-III, and if b is green then a ball is chosen randomly from Box-IV. The conditional probability of the event 'one of the chosen balls is white' given that the event 'at least one of the chosen balls is green' has happened, is equal to

(A) $\frac{15}{256}$

(B) $\frac{3}{16}$

(C) $\frac{5}{52}$

(D) $\frac{1}{8}$

Answer: C

Q.18 For positive integer n , define

$$f(n) = n + \frac{16 + 5n - 3n^2}{4n + 3n^2} + \frac{32 + n - 3n^2}{8n + 3n^2} + \frac{48 - 3n - 3n^2}{12n + 3n^2} + \dots + \frac{25n - 7n^2}{7n^2} .$$

Then, the value of $\lim_{n \rightarrow \infty} f(n)$ is equal to

(A) $3 + \frac{4}{3} \log_e 7$

(B) $4 - \frac{3}{4} \log_e \left(\frac{7}{3}\right)$

(C) $4 - \frac{4}{3} \log_e \left(\frac{7}{3}\right)$

(D) $3 + \frac{3}{4} \log_e 7$

Answer: B

END OF THE QUESTION PAPER

SECTION 1

- This section contains **EIGHT (08)** questions.
- The answer to each question is a **SINGLE DIGIT INTEGER ranging from 0 TO 9, BOTH INCLUSIVE**.
- For each question, enter the correct integer corresponding to the answer using the mouse and the on-screen virtual numeric keypad in the place designated to enter the answer.
- Answer to each question will be evaluated according to the following marking scheme:
Full Marks : +3 If **ONLY** the correct integer is entered;
Zero Marks : 0 If the question is unanswered;
Negative Marks : -1 In all other cases.

- Q.1 A particle of mass 1 kg is subjected to a force which depends on the position as $\vec{F} = -k(x\hat{i} + y\hat{j}) \text{ kg m s}^{-2}$ with $k = 1 \text{ kg s}^{-2}$. At time $t = 0$, the particle's position $\vec{r} = \left(\frac{1}{\sqrt{2}}\hat{i} + \sqrt{2}\hat{j}\right) \text{ m}$ and its velocity $\vec{v} = \left(-\sqrt{2}\hat{i} + \sqrt{2}\hat{j} + \frac{2}{\pi}\hat{k}\right) \text{ m s}^{-1}$. Let v_x and v_y denote the x and the y components of the particle's velocity, respectively. **Ignore gravity**. When $z = 0.5 \text{ m}$, the value of $(x v_y - y v_x)$ is 3 m^2s^{-1} .
- Q.2 In a radioactive decay chain reaction, ${}^{230}_{90}\text{Th}$ nucleus decays into ${}^{214}_{84}\text{Po}$ nucleus. The ratio of the number of α to number of β^- particles emitted in this process is 2.
- Q.3 Two resistances $R_1 = X \Omega$ and $R_2 = 1 \Omega$ are connected to a wire AB of uniform resistivity, as shown in the figure. The radius of the wire varies linearly along its axis from 0.2 mm at A to 1 mm at B . A galvanometer (G) connected to the center of the wire, 50 cm from each end along its axis, shows zero deflection when A and B are connected to a battery. The value of X is 5.

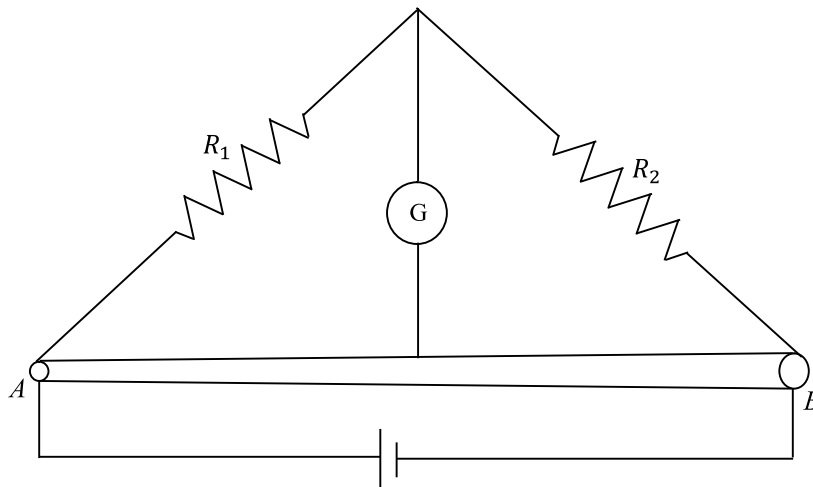

Q.4 In a particular system of units, a physical quantity can be expressed in terms of the electric charge e , electron mass m_e , Planck's constant h , and Coulomb's constant $k = \frac{1}{4\pi\epsilon_0}$, where ϵ_0 is the permittivity of vacuum. In terms of these physical constants, the dimension of the magnetic field is $[B] = [e]^\alpha [m_e]^\beta [h]^\gamma [k]^\delta$. The value of $\alpha + \beta + \gamma + \delta$ is 4.

Q.5 Consider a configuration of n identical units, each consisting of three layers. The first layer is a column of air of height $h = \frac{1}{3} \text{ cm}$, and the second and third layers are of equal thickness $d = \frac{\sqrt{3}-1}{2} \text{ cm}$, and refractive indices $\mu_1 = \sqrt{\frac{3}{2}}$ and $\mu_2 = \sqrt{3}$, respectively. A light source O is placed on the top of the first unit, as shown in the figure. A ray of light from O is incident on the second layer of the first unit at an angle of $\theta = 60^\circ$ to the normal. For a specific value of n , the ray of light emerges from the bottom of the configuration at a distance $l = \frac{8}{\sqrt{3}} \text{ cm}$, as shown in the figure. The value of n is 4.



Q.6 A charge q is surrounded by a closed surface consisting of an inverted cone of height h and base radius R , and a hemisphere of radius R as shown in the figure. The electric flux through the conical surface is $\frac{nq}{6\epsilon_0}$ (in SI units). The value of n is 3.

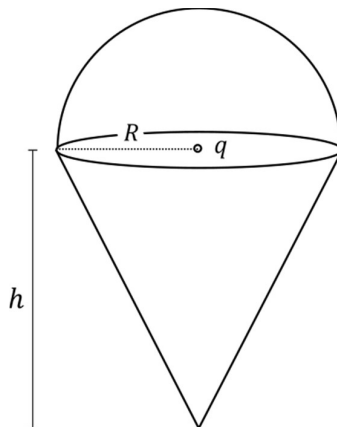

- Q.7 On a frictionless horizontal plane, a bob of mass $m = 0.1 \text{ kg}$ is attached to a spring with natural length $l_0 = 0.1 \text{ m}$. The spring constant is $k_1 = 0.009 \text{ Nm}^{-1}$ when the length of the spring $l > l_0$ and is $k_2 = 0.016 \text{ Nm}^{-1}$ when $l < l_0$. Initially the bob is released from $l = 0.15 \text{ m}$. Assume that Hooke's law remains valid throughout the motion. If the time period of the full oscillation is $T = (n \pi) \text{ s}$, then the integer closest to n is 6.
- Q.8 An object and a concave mirror of focal length $f = 10 \text{ cm}$ both move along the principal axis of the mirror with constant speeds. The object moves with speed $V_0 = 15 \text{ cm s}^{-1}$ towards the mirror with respect to a laboratory frame. The distance between the object and the mirror at a given moment is denoted by u . When $u = 30 \text{ cm}$, the speed of the mirror V_m is such that the image is instantaneously at rest with respect to the laboratory frame, and the object forms a real image. The magnitude of V_m is 3 cm s^{-1} .

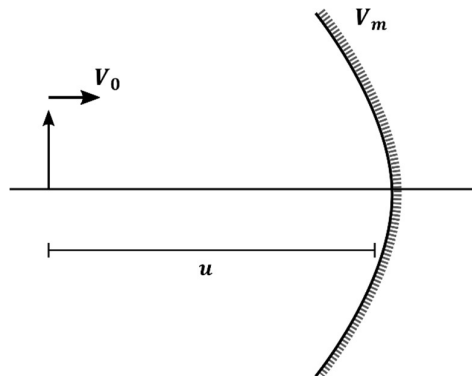

SECTION 2

- This section contains **NINE (09)** questions.
- Each question has **FOUR** options (A), (B), (C) and (D). **ONE OR MORE THAN ONE** of these four option(s) is (are) correct answer(s).
- For each question, choose the option(s) corresponding to (all) the correct answer(s).
- Answer to each question will be evaluated according to the following marking scheme:
 - Full Marks* : +4 **ONLY** if (all) the correct option(s) is(are) chosen;
 - Partial Marks* : +3 If all the four options are correct but **ONLY** three options are chosen;
 - Partial Marks* : +2 If three or more options are correct but **ONLY** two options are chosen, both of which are correct;
 - Partial Marks* : +1 If two or more options are correct but **ONLY** one option is chosen and it is a correct option;
 - Zero Marks* : 0 If unanswered;
 - Negative Marks* : -2 In all other cases.

- Q.9 In the figure, the inner (shaded) region A represents a sphere of radius $r_A = 1$, within which the electrostatic charge density varies with the radial distance r from the center as $\rho_A = kr$, where k is positive. In the spherical shell B of outer radius r_B , the electrostatic charge density varies as $\rho_B = \frac{2k}{r}$. Assume that dimensions are taken care of. All physical quantities are in their SI units.

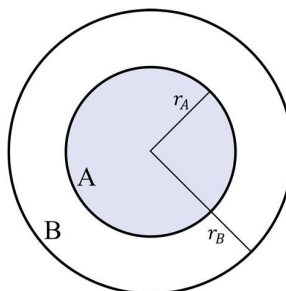

Which of the following statement(s) is(are) correct?

- (A) If $r_B = \sqrt{\frac{3}{2}}$, then the electric field is zero everywhere outside B .
- (B) If $r_B = \frac{3}{2}$, then the electric potential just outside B is $\frac{k}{\epsilon_0}$.
- (C) If $r_B = 2$, then the total charge of the configuration is $15\pi k$.
- (D) If $r_B = \frac{5}{2}$, then the magnitude of the electric field just outside B is $\frac{13\pi k}{\epsilon_0}$.

Answer: B

- Q.10 In Circuit-1 and Circuit-2 shown in the figures, $R_1 = 1 \Omega$, $R_2 = 2 \Omega$ and $R_3 = 3 \Omega$. P_1 and P_2 are the power dissipations in Circuit-1 and Circuit-2 when the switches S_1 and S_2 are in open conditions, respectively. Q_1 and Q_2 are the power dissipations in Circuit-1 and Circuit-2 when the switches S_1 and S_2 are in closed conditions, respectively.

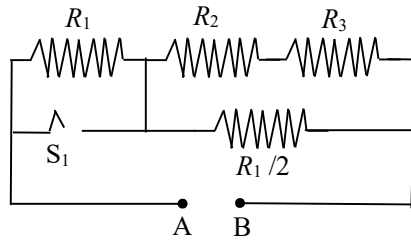

Circuit-1

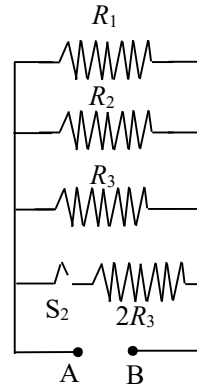

Circuit-2

Which of the following statement(s) is(are) correct?

- (A) When a voltage source of $6 V$ is connected across A and B in both circuits, $P_1 < P_2$.
- (B) When a constant current source of 2 Amp is connected across A and B in both circuits, $P_1 > P_2$.
- (C) When a voltage source of $6 V$ is connected across A and B in Circuit-1, $Q_1 > P_1$.
- (D) When a constant current source of 2 Amp is connected across A and B in both circuits, $Q_2 < Q_1$.

Answer: A, B, C

- Q.11 A bubble has surface tension S . The ideal gas inside the bubble has ratio of specific heats $\gamma = \frac{5}{3}$. The bubble is exposed to the atmosphere and it always retains its spherical shape. When the atmospheric pressure is P_{a1} , the radius of the bubble is found to be r_1 and the temperature of the enclosed gas is T_1 . When the atmospheric pressure is P_{a2} , the radius of the bubble and the temperature of the enclosed gas are r_2 and T_2 , respectively.

Which of the following statement(s) is(are) correct?

- (A) If the surface of the bubble is a perfect heat insulator, then $\left(\frac{r_1}{r_2}\right)^5 = \frac{P_{a2} + \frac{2S}{r_2}}{P_{a1} + \frac{2S}{r_1}}$.
- (B) If the surface of the bubble is a perfect heat insulator, then the total internal energy of the bubble including its surface energy does not change with the external atmospheric pressure.
- (C) If the surface of the bubble is a perfect heat conductor and the change in atmospheric temperature is negligible, then $\left(\frac{r_1}{r_2}\right)^3 = \frac{P_{a2} + \frac{4S}{r_2}}{P_{a1} + \frac{4S}{r_1}}$.
- (D) If the surface of the bubble is a perfect heat insulator, then $\left(\frac{T_2}{T_1}\right)^{\frac{5}{2}} = \frac{P_{a2} + \frac{4S}{r_2}}{P_{a1} + \frac{4S}{r_1}}$.

Answer: C, D

- Q.12 A disk of radius R with uniform positive charge density σ is placed on the xy plane with its center at the origin. The Coulomb potential along the z -axis is

$$V(z) = \frac{\sigma}{2\epsilon_0} (\sqrt{R^2 + z^2} - z).$$

A particle of positive charge q is placed initially at rest at a point on the z axis with $z = z_0$ and $z_0 > 0$. In addition to the Coulomb force, the particle experiences a vertical force $\vec{F} = -c \hat{k}$ with $c > 0$. Let $\beta = \frac{2c\epsilon_0}{q\sigma}$. Which of the following statement(s) is(are) correct?

- (A) For $\beta = \frac{1}{4}$ and $z_0 = \frac{25}{7}R$, the particle reaches the origin.
 (B) For $\beta = \frac{1}{4}$ and $z_0 = \frac{3}{7}R$, the particle reaches the origin.
 (C) For $\beta = \frac{1}{4}$ and $z_0 = \frac{R}{\sqrt{3}}$, the particle returns back to $z = z_0$.
 (D) For $\beta > 1$ and $z_0 > 0$, the particle always reaches the origin.

Answer: A, C, D

- Q.13 A double slit setup is shown in the figure. One of the slits is in medium 2 of refractive index n_2 . The other slit is at the interface of this medium with another medium 1 of refractive index $n_1 (\neq n_2)$. The line joining the slits is perpendicular to the interface and the distance between the slits is d . The slit widths are much smaller than d . A monochromatic parallel beam of light is incident on the slits from medium 1. A detector is placed in medium 2 at a large distance from the slits, and at an angle θ from the line joining them, so that θ equals the angle of refraction of the beam. Consider two approximately parallel rays from the slits received by the detector.

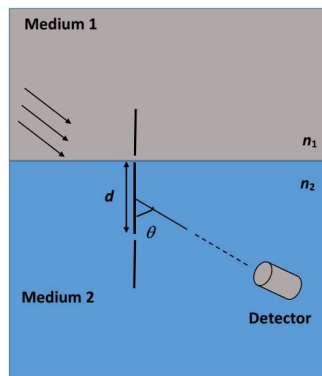

Which of the following statement(s) is(are) correct?

- (A) The phase difference between the two rays is independent of d .
 (B) The two rays interfere constructively at the detector.
 (C) The phase difference between the two rays depends on n_1 but is independent of n_2 .
 (D) The phase difference between the two rays vanishes only for certain values of d and the angle of incidence of the beam, with θ being the corresponding angle of refraction.

Answer: A, B

- Q.14 In the given P - V diagram, a monoatomic gas ($\gamma = \frac{5}{3}$) is first compressed adiabatically from state A to state B . Then it expands isothermally from state B to state C . [Given: $(\frac{1}{3})^{0.6} \approx 0.5$, $\ln 2 \approx 0.7$].

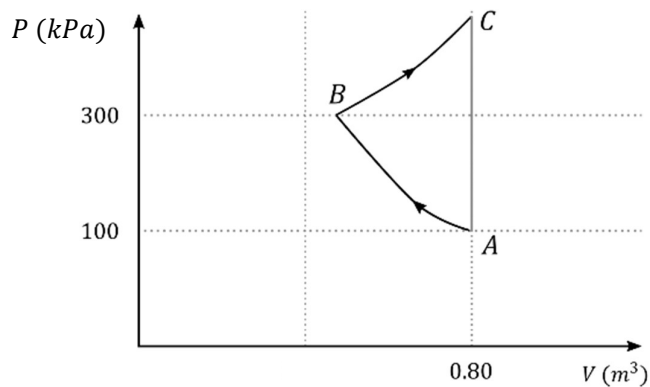

Which of the following statement(s) is(are) correct?

- (A) The magnitude of the total work done in the process $A \rightarrow B \rightarrow C$ is 144 kJ .
- (B) The magnitude of the work done in the process $B \rightarrow C$ is 84 kJ .
- (C) The magnitude of the work done in the process $A \rightarrow B$ is 60 kJ .
- (D) The magnitude of the work done in the process $C \rightarrow A$ is zero.

Answer: B, C, D

SECTION 3

- This section contains **FOUR (04)** questions.
- Each question has **FOUR** options (A), (B), (C) and (D). **ONLY ONE** of these four options is the correct answer.
- For each question, choose the option corresponding to the correct answer.
- Answer to each question will be evaluated according to the following marking scheme:
 - Full Marks* : +3 If **ONLY** the correct option is chosen;
 - Zero Marks* : 0 If none of the options is chosen (i.e. the question is unanswered);
 - Negative Marks* : -1 In all other cases.

- Q.15 A flat surface of a thin uniform disk A of radius R is glued to a horizontal table. Another thin uniform disk B of mass M and with the same radius R rolls without slipping on the circumference of A , as shown in the figure. A flat surface of B also lies on the plane of the table. The center of mass of B has fixed angular speed ω about the vertical axis passing through the center of A . The angular momentum of B is $nM\omega R^2$ with respect to the center of A . Which of the following is the value of n ?

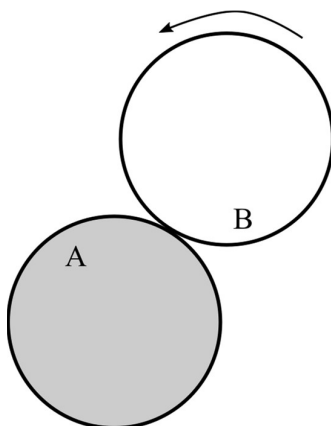

- (A) 2 (B) 5 (C) $\frac{7}{2}$ (D) $\frac{9}{2}$

Answer: B

- Q.16 When light of a given wavelength is incident on a metallic surface, the minimum potential needed to stop the emitted photoelectrons is 6.0 V . This potential drops to 0.6 V if another source with wavelength four times that of the first one and intensity half of the first one is used. What are the wavelength of the first source and the work function of the metal, respectively? [Take $\frac{hc}{e} = 1.24 \times 10^{-6}\text{ J m C}^{-1}$.]

- (A) $1.72 \times 10^{-7}\text{ m}$, 1.20 eV
 (B) $1.72 \times 10^{-7}\text{ m}$, 5.60 eV
 (C) $3.78 \times 10^{-7}\text{ m}$, 5.60 eV
 (D) $3.78 \times 10^{-7}\text{ m}$, 1.20 eV

Answer: A

- Q.17 Area of the cross-section of a wire is measured using a screw gauge. The pitch of the main scale is 0.5 mm. The circular scale has 100 divisions and for one full rotation of the circular scale, the main scale shifts by two divisions. The measured readings are listed below.

**Question Dropped
Marks for All**

Measurement condition	Main scale reading	Circular scale reading
Two arms of gauge touching each other without wire	0 division	4 divisions
Attempt-1: With wire	4 divisions	20 divisions
Attempt-2: With wire	4 divisions	16 divisions

What are the diameter and cross-sectional area of the wire measured using the screw gauge?

- (A) $2.22 \pm 0.02 \text{ mm}$, $\pi(1.23 \pm 0.02) \text{ mm}^2$
 (B) $2.22 \pm 0.01 \text{ mm}$, $\pi(1.23 \pm 0.01) \text{ mm}^2$
 (C) $2.14 \pm 0.02 \text{ mm}$, $\pi(1.14 \pm 0.02) \text{ mm}^2$
 (D) $2.14 \pm 0.01 \text{ mm}$, $\pi(1.14 \pm 0.01) \text{ mm}^2$
- Q.18 Which one of the following options represents the magnetic field \vec{B} at O due to the current flowing in the given wire segments lying on the xy plane?

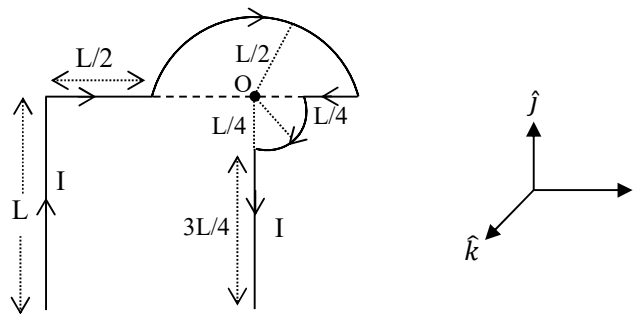

- (A) $\vec{B} = \frac{-\mu_0 I}{L} \left(\frac{3}{2} + \frac{1}{4\sqrt{2}\pi} \right) \hat{k}$
 (B) $\vec{B} = -\frac{\mu_0 I}{L} \left(\frac{3}{2} + \frac{1}{2\sqrt{2}\pi} \right) \hat{k}$
 (C) $\vec{B} = \frac{-\mu_0 I}{L} \left(1 + \frac{1}{4\sqrt{2}\pi} \right) \hat{k}$
 (D) $\vec{B} = \frac{-\mu_0 I}{L} \left(1 + \frac{1}{4\pi} \right) \hat{k}$

Answer: C

END OF THE QUESTION PAPER

SECTION 1 (Maximum marks: 24)

- This section contains **EIGHT (08)** questions.
- The answer to each question is a **SINGLE DIGIT INTEGER ranging from 0 TO 9, BOTH INCLUSIVE**.
- For each question, enter the correct integer corresponding to the answer using the mouse and the on-screen virtual numeric keypad in the place designated to enter the answer.
- Answer to each question will be evaluated according to the following marking scheme:
Full Marks : +3 If **ONLY** the correct integer is entered;
Zero Marks : 0 If the question is unanswered;
Negative Marks : -1 In all other cases.

Q.1 Concentration of H_2SO_4 and Na_2SO_4 in a solution is 1 M and 1.8×10^{-2} M, respectively. Molar solubility of PbSO_4 in the same solution is $X \times 10^{-Y}$ M (expressed in scientific notation). The value of Y is 6.

[Given: Solubility product of PbSO_4 (K_{sp}) = 1.6×10^{-8} . For H_2SO_4 , K_{a1} is very large and $K_{a2} = 1.2 \times 10^{-2}$]

Q.2 An aqueous solution is prepared by dissolving 0.1 mol of an ionic salt in 1.8 kg of water at 35 °C. The salt remains 90% dissociated in the solution. The vapour pressure of the solution is 59.724 mm of Hg. Vapor pressure of water at 35 °C is 60.000 mm of Hg. The number of ions present per formula unit of the ionic salt is 5.

- Q.3 Consider the strong electrolytes Z_mX_n , U_mY_p and V_mX_n . Limiting molar conductivity (Λ^0) of U_mY_p and V_mX_n are 250 and 440 $S\text{ cm}^2\text{ mol}^{-1}$, respectively. The value of $(m + n + p)$ is 7.

Given:

Ion	Z^{n+}	U^{p+}	V^{n+}	X^{m-}	Y^{m-}
λ^0 ($S\text{ cm}^2\text{ mol}^{-1}$)	50.0	25.0	100.0	80.0	100.0

λ^0 is the limiting molar conductivity of ions

The plot of molar conductivity (Λ) of Z_mX_n vs $c^{1/2}$ is given below.

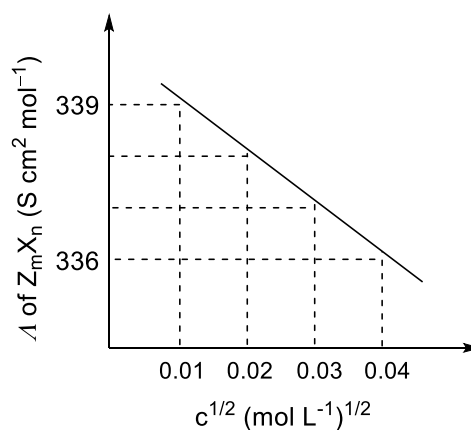

- Q.4 The reaction of Xe and O_2F_2 gives a Xe compound **P**. The number of moles of HF produced by the complete hydrolysis of 1 mol of **P** is 4.

- Q.5 Thermal decomposition of $AgNO_3$ produces two paramagnetic gases. The total number of electrons present in the antibonding molecular orbitals of the gas that has the higher number of unpaired electrons is 6.

- Q.6 The number of isomeric tetraenes (**NOT** containing *sp*-hybridized carbon atoms) that can be formed from the following reaction sequence is 2.

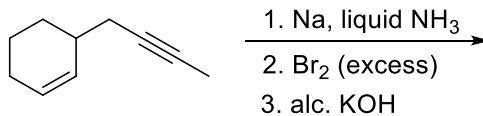

- Q.7 The number of $-\text{CH}_2-$ (methylene) groups in the product formed from the following reaction sequence is 0.

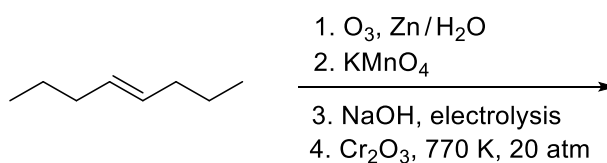

- Q.8 The total number of chiral molecules formed from one molecule of **P** on complete ozonolysis (O_3 , $\text{Zn}/\text{H}_2\text{O}$) is 2.

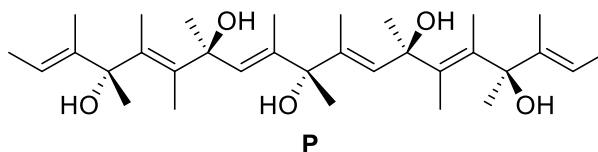

SECTION 2 (Maximum marks: 24)

- This section contains **SIX (06)** questions.
- Each question has **FOUR** options (A), (B), (C) and (D). **ONE OR MORE THAN ONE** of these four option(s) is (are) correct answer(s).
- For each question, choose the option(s) corresponding to (all) the correct answer(s).
- Answer to each question will be evaluated according to the following marking scheme:

Full Marks : +4 **ONLY** if (all) the correct option(s) is(are) chosen;

Partial Marks : +3 If all the four options are correct but **ONLY** three options are chosen;

Partial Marks : +2 If three or more options are correct but **ONLY** two options are chosen, both of which are correct;

Partial Marks : +1 If two or more options are correct but **ONLY** one option is chosen and it is a correct option;

Zero Marks : 0 If unanswered;

Negative Marks : -2 In all other cases.

Q.9 To check the principle of multiple proportions, a series of pure binary compounds ($P_m Q_n$) were analyzed and their composition is tabulated below. The correct option(s) is(are)

Compound	Weight % of P	Weight % of Q
1	50	50
2	44.4	55.6
3	40	60

- (A) If empirical formula of compound **3** is P_3Q_4 , then the empirical formula of compound **2** is P_3Q_5 .
- (B) If empirical formula of compound **3** is P_3Q_2 and atomic weight of element P is 20, then the atomic weight of Q is 45.
- (C) If empirical formula of compound **2** is PQ, then the empirical formula of the compound **1** is P_5Q_4 .
- (D) If atomic weight of P and Q are 70 and 35, respectively, then the empirical formula of compound **1** is P_2Q .

Answer: B, C

Q.10 The correct option(s) about entropy (S) is(are)

[R = gas constant, F = Faraday constant, T = Temperature]

- (A) For the reaction, $M(s) + 2H^+(aq) \rightarrow H_2(g) + M^{2+}(aq)$, if $\frac{dE_{cell}}{dT} = \frac{R}{F}$, then the entropy change of the reaction is R (assume that entropy and internal energy changes are temperature independent).
- (B) The cell reaction, $Pt(s) | H_2(g, 1bar) | H^+(aq, 0.01M) || H^+(aq, 0.1M) | H_2(g, 1bar) | Pt(s)$, is an entropy driven process.
- (C) For racemization of an optically active compound, $\Delta S > 0$.
- (D) $\Delta S > 0$, for $[Ni(H_2O)_6]^{2+} + 3 en \rightarrow [Ni(en)_3]^{2+} + 6H_2O$ (where en = ethylenediamine).

Answer: B, C, D

Q.11 The compound(s) which react(s) with NH_3 to give boron nitride (BN) is(are)

- (A) B (B) B_2H_6 (C) B_2O_3 (D) HBF_4

Answer: [B, C] or [A, B, C]

Q.12 The correct option(s) related to the extraction of iron from its ore in the blast furnace operating in the temperature range 900 – 1500 K is(are)

- (A) Limestone is used to remove silicate impurity.
- (B) Pig iron obtained from blast furnace contains about 4% carbon.
- (C) Coke (C) converts CO_2 to CO.
- (D) Exhaust gases consist of NO_2 and CO.

Answer: A, B, C

Q.13 Considering the following reaction sequence, the correct statement(s) is(are)

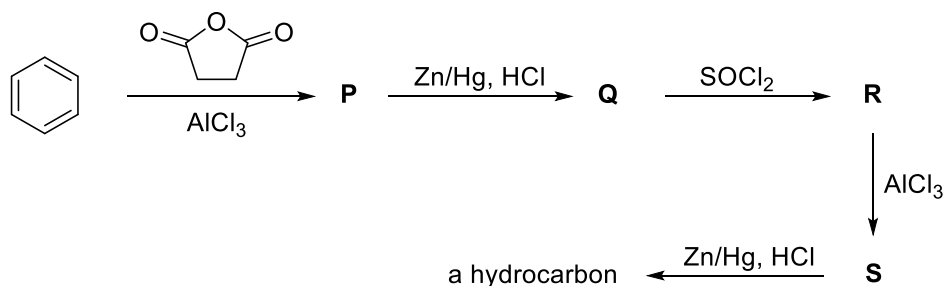

- (A) Compounds **P** and **Q** are carboxylic acids.
 (B) Compound **S** decolorizes bromine water.
 (C) Compounds **P** and **S** react with hydroxylamine to give the corresponding oximes.
 (D) Compound **R** reacts with dialkylcadmium to give the corresponding tertiary alcohol.

Answer: A, C

Q.14 Among the following, the correct statement(s) about polymers is(are)

- (A) The polymerization of chloroprene gives natural rubber.
 (B) Teflon is prepared from tetrafluoroethene by heating it with persulphate catalyst at high pressures.
 (C) PVC are thermoplastic polymers.
 (D) Ethene at 350-570 K temperature and 1000-2000 atm pressure in the presence of a peroxide initiator yields high density polythene.

Answer: B, C

SECTION 3 (Maximum marks: 12)

- This section contains **FOUR (04)** questions.
- Each question has **FOUR** options (A), (B), (C) and (D). **ONLY ONE** of these four options is the correct answer.
- For each question, choose the option corresponding to the correct answer.
- Answer to each question will be evaluated according to the following marking scheme:
Full Marks : +3 If **ONLY** the correct option is chosen;
Zero Marks : 0 If none of the options is chosen (i.e. the question is unanswered);
Negative Marks : -1 In all other cases.

Q.15 Atom X occupies the fcc lattice sites as well as alternate tetrahedral voids of the same lattice. The packing efficiency (in %) of the resultant solid is closest to

- (A) 25 (B) 35 (C) 55 (D) 75

Answer: B

Q.16 The reaction of HClO_3 with HCl gives a paramagnetic gas, which upon reaction with O_3 produces

- (A) Cl_2O (B) ClO_2 (C) Cl_2O_6 (D) Cl_2O_7

Answer: C

Q.17 The reaction of $\text{Pb}(\text{NO}_3)_2$ and NaCl in water produces a precipitate that dissolves upon the addition of HCl of appropriate concentration. The dissolution of the precipitate is due to the formation of

- (A) PbCl_2 (B) PbCl_4 (C) $[\text{PbCl}_4]^{2-}$ (D) $[\text{PbCl}_6]^{2-}$

Answer: C

Q.18 Treatment of D-glucose with aqueous NaOH results in a mixture of monosaccharides, which are

(A)

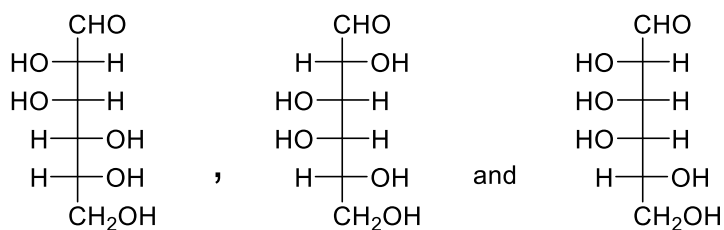

(B)

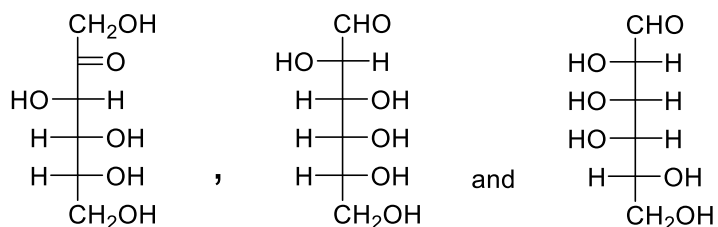

(C)

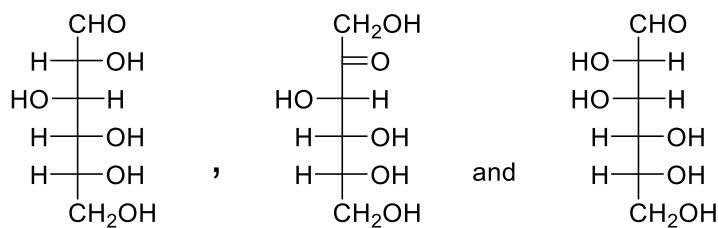

(D)

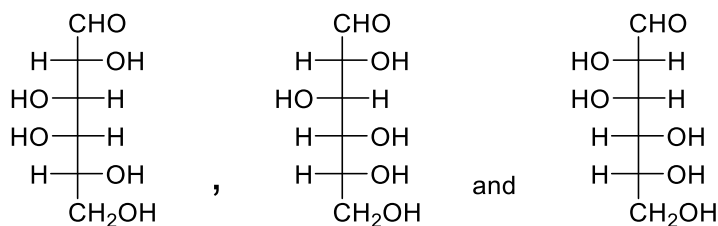

Answer: C

END OF THE QUESTION PAPER