

# **Chapter - 12**

## **Electricity**



Read the information given below and answer four out of five following questions.

Suresh bought a packet of 100 LEDs to make his own lights for decoration in his house. The packet on the LEDs had the following printed on a label:

**LED 2835, 0.2 W, 30 Lumens, 3 V**

To understand how he should connect the LEDs, he referred to the following circuit diagram on a website.

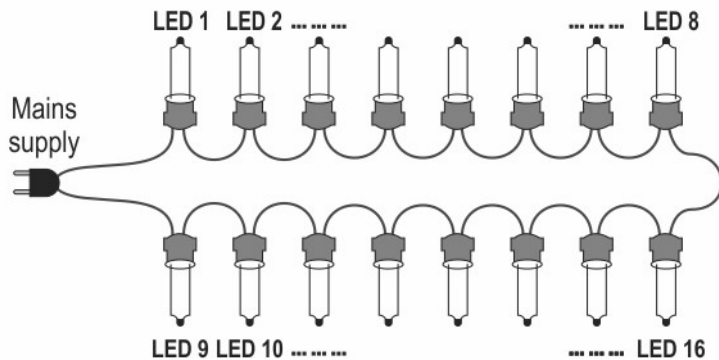

**Q: 1 Which of the following describes how the LEDs are connected in the circuit diagram?**

- 1** all in series
- 2** all in parallel
- 3** 8 each in a series combination, and the two combinations in parallel
- 4** 8 each in a parallel combination, and the two combinations in series

**Q: 2 If the LED marked 'LED 2' in the diagram stops working, which other LEDs will also stop working?**

*(Note: When an LED stops working, current cannot flow across it.)*

- 1** only LED 3 to LED 8
- 2** only LED 3 to LED 8 and LED 1
- 3** all the other LEDs in the circuit
- 4** none of the other LEDs in the circuit

**Q: 3 Suresh decided to connect all the LEDs in his lights in a series combination.**

**How many LEDs will he need to connect if he is going to connect the lights to a 240 V mains supply so that the LEDs work at their power rating?**

- 1** 16
- 2** 80
- 3** 240
- 4** 1200

**Q: 4 What will happen if he connects 100 LEDs, all in a parallel combination, to the 240 V mains supply?**

- 1** Each LED will work as expected since the available voltage is more than 3 V.
- 2** Each LED will have a potential difference of 220 V and therefore they will get damaged.
- 3** Each LED will glow but the ones closer in the circuit to the main supply will glow brighter.
- 4** Each LED will have a potential difference of 2.4 V across it and therefore will glow dimmer than normal.



**Q: 5** How much current is each LED expected to draw when used according to the ratings given in the label?

**1** 0.067 A

**2** 0.600 A

**3** 10 A

**4** 15 A

**Q: 6** The diagram below shows how Amita had connected a circuit to verify Ohm's law.

[5]

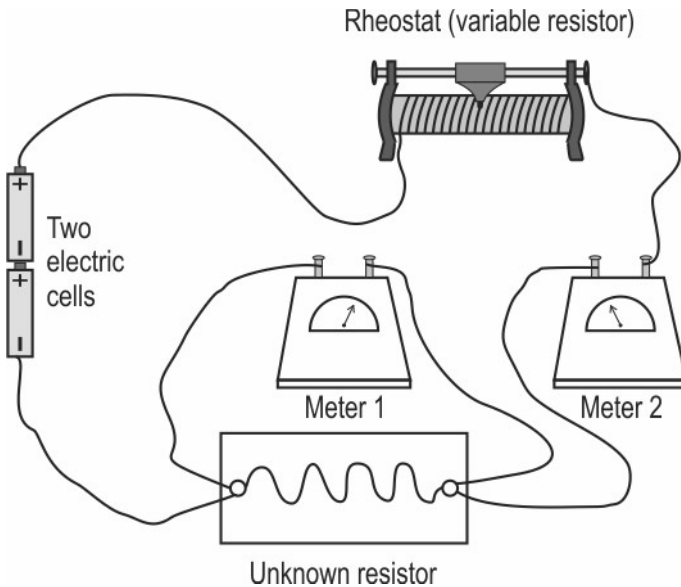

(a) Identify which of the devices in the circuit is an ammeter. Justify your answer.

(b) Draw a circuit diagram with appropriate symbols for the circuit shown in the diagram above.

(c) Amita forgot to put a switch in the circuit. During the experiment, the wire labelled 'Unknown resistor' became hot. The resistivity of the material of the wire increases with temperature. Draw two potential difference vs current graphs (in the same diagram): (i) as expected by Amita, (ii) as based on actual observation she would make.



**Q: 7** Answer the questions based on the electric circuit shown below. All the four bulbs are identical. [2]

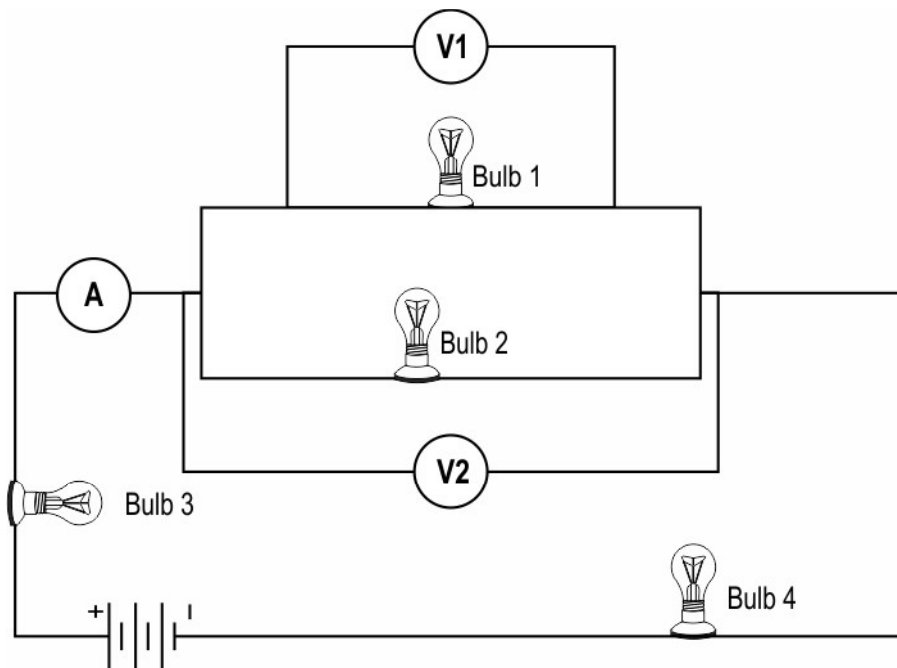

(a) How does the voltage reading on voltmeter 1 compare with the voltage reading on voltmeter 2?

(b) Identify the bulb(s) through which a current equal to the reading on the ammeter flows.

**Q: 8** Suresh arranges the electric circuit shown below to measure the current flowing through and the potential difference of a bulb. [1]

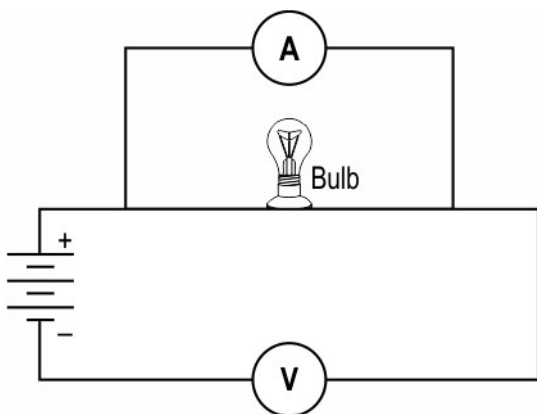

Is the circuit correct? If not, then identify the mistake.



**Q: 9** Study the circuit diagram given below. You are given one extra resistor. By drawing a new circuit diagram, show how you can connect the extra resistor to increase the reading on the ammeter in the circuit below. [1]

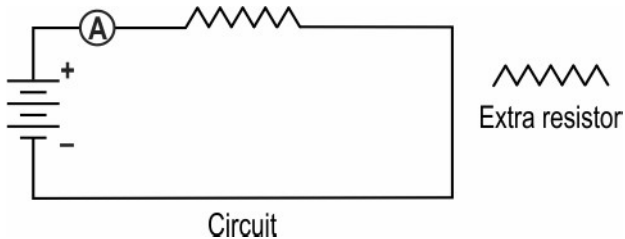

**Q: 10** Priya has a copper wire and an aluminium wire of the same length. [2]

Can the electrical resistance of the two wires be the same? Justify your answer.

**Q: 11** Three resistors in a circuit are attached as shown here. The resistance of F and G are 10 ohm and 5 ohm respectively. The resistance of E is unknown. These resistors are connected to a battery with potential difference 6 V. [5]

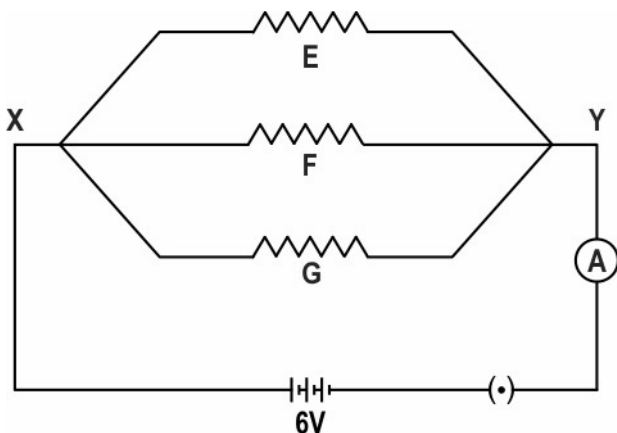

- (a) What is the term used to describe such an arrangement of resistors?
- (b) What is the resistance of E if 0.3 A current flows through it?
- (c) What is the total current flowing in the circuit?

**Q: 12** You are given three identical 10 ohm resistors and a 12 V cell. [2]

Draw the circuit diagram to show how the resistors can be connected with the 12 V cell so that the total heat produced in the circuit is the MINIMUM.



**Q: 13** Observe the circuit shown below. All the three switches are open.

[1]

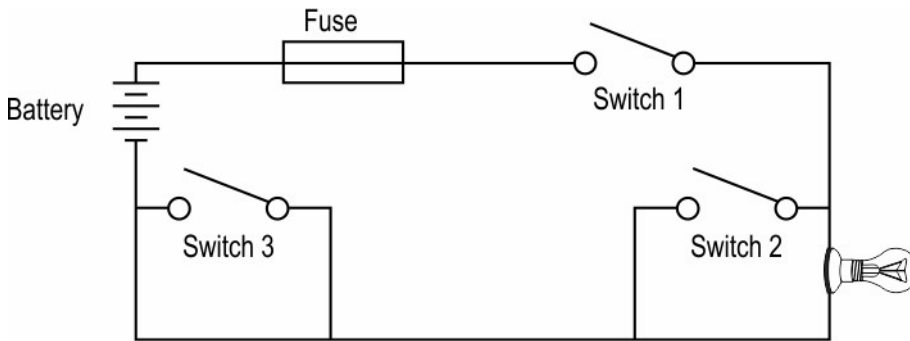

Identify the switch/switches that on being closed will cause the fuse to blow.

**Q: 14** An incandescent bulb works on the heating effect of electric current. When a current passes through the filament of a bulb it heats the filament to a high temperature which causes the filament to glow.

[2]

The graph below shows the variation in the current through a bulb immediately after it is switched on. The current decreases from 1 A at time  $t=0$  to 0.5 A at  $t=t_1$ . The voltage of the power supply is 200 V and remains constant throughout.

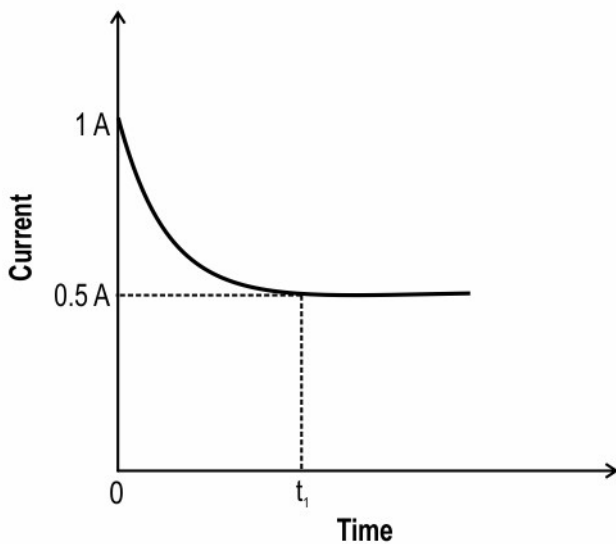

(a) Based on the graph, state how the resistance of the bulb filament changes as the temperature increases from time  $t=0$  to  $t=t_1$ .

(b) What is the power consumed by the bulb when it is glowing at its full brightness?



**Q: 15** The picture P below shows an electrical tester being used to check the electric point. [2]  
The picture Q is a diagram showing the internal parts of the electrical tester.

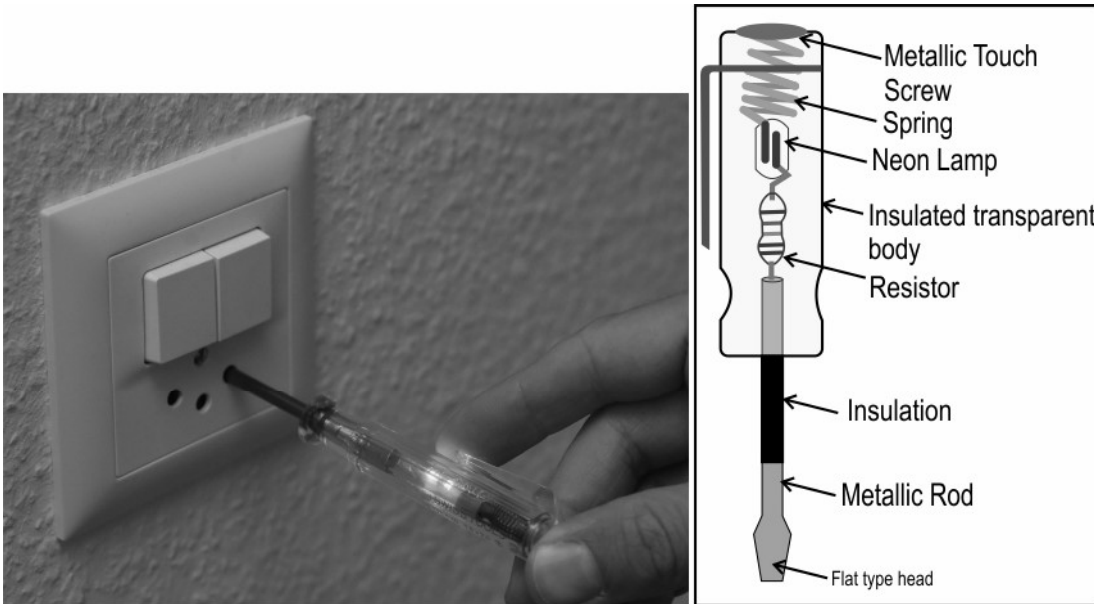

**P**

**Q**

- (a) Give the most likely explanation why an electrician does not get an electric shock when he touches the metallic touch screw and the lamp of the tester glows.
- (b) Which part of the tester prevents the shock when the metallic touch screw is touched?



The table below gives the correct answer for each multiple-choice question in this test.

<b>Q.No</b>	<b>Correct Answers</b>
<b>1</b>	<b>1</b>
<b>2</b>	<b>3</b>
<b>3</b>	<b>2</b>
<b>4</b>	<b>2</b>
<b>5</b>	<b>1</b>



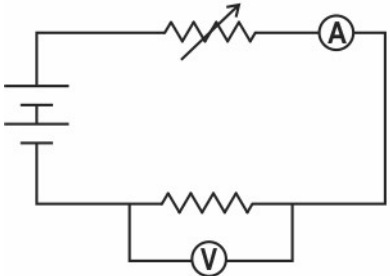
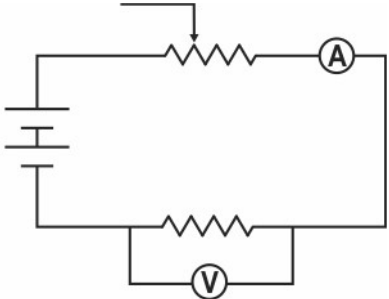
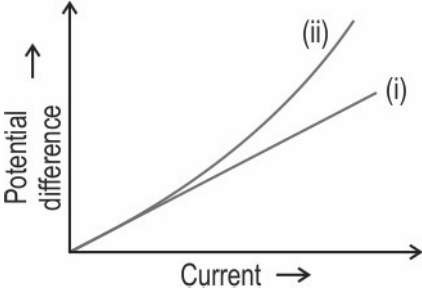

Q.No	Teacher should award marks if students have done the following:	Marks
6	<p>(a)</p> <ul style="list-style-type: none"> <li>- Meter 2 [0.5 marks]</li> <li>- because it is connected in series with the unknown resistor through which the current needs to be measured [0.5 marks]</li> </ul>	1
	<p>(b)</p> <ul style="list-style-type: none"> <li>- Correct connections for the cell, the unknown resistor and the rheostat in the diagram [0.5 marks]</li> <li>- Correct connections for the two meters in the diagram [0.5 marks]</li> <li>- Use of correct symbols for all components [1 mark]</li> </ul> <div style="display: flex; align-items: center; justify-content: center;">  <span style="margin: 0 20px;">OR</span>  </div>	2
	<p>(c)</p> <ul style="list-style-type: none"> <li>(i) straight line passing through origin [1 mark]</li> <li>(ii) curved line with an increasing slope [1 mark]</li> </ul> <div style="text-align: center;">  </div>	2
7	<p>(a) The voltage reading on voltmeter 1 will be the same as the reading on voltmeter 2.</p>	1
	<p>(b) 0.5 marks each for the following:</p> <ul style="list-style-type: none"> <li>- bulb 3</li> <li>- bulb 4</li> </ul> <p>(No marks to be awarded if Bulb 1 and/or 2 is included in the answer.)</p>	1

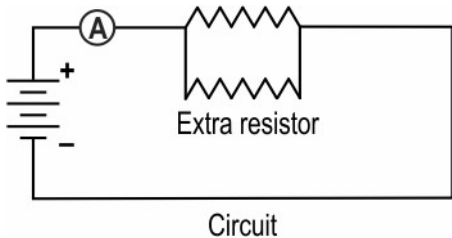

Q.No	Teacher should award marks if students have done the following:	Marks
8	<p>0.5 marks for each of the following:</p> <ul style="list-style-type: none"> <li>- The circuit is incorrect.</li> <li>- The positions of the ammeter and voltmeter have been interchanged.</li> </ul>	1
9		1
10	<p>Yes, the electrical resistance of the two wires can be the same. (No marks to be awarded if justification is not written.)</p>	1
	<p>if the area of cross-section of the two wires is different</p> <p>OR</p> <p>if the thickness of the two wires is different</p>	1
11	<p>(a) Resistors are attached in parallel</p>	1
	<p>(b) Resistance of <math>E = R_1</math>  <math>I = V/R</math>  <math>0.3 = 6/R</math>  <math>R_1 = 6/0.3</math>  <math>R_1 = 20 \text{ ohm}</math></p> <p>[1.5 marks for the steps to calculate <math>R_1</math> and 0.5 marks for final answer]</p>	2
	<p>(c) Total current (<math>I</math>) = <math>V/R_1 + V/R_2 + V/R_3</math>  <math>= 6/20 + 6/10 + 6/5</math>  <math>= 0.3 + 0.6 + 1.2</math>  <math>= 2.1 \text{ A}</math></p> <p>[1.5 marks for the steps to calculate <math>R_1</math> and 0.5 marks for final answer]</p>	2

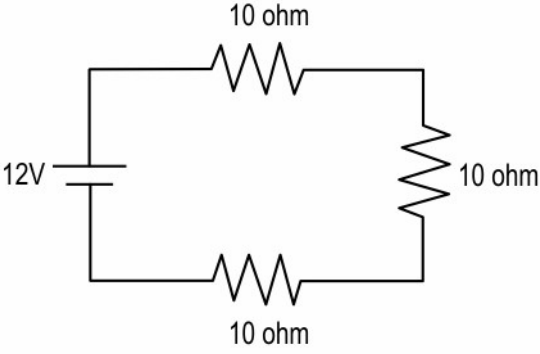

Q.No	Teacher should award marks if students have done the following:	Marks
12	 <p>The diagram shows a series circuit. On the left, there is a 12V battery. Moving clockwise from the battery, there is a resistor labeled '10 ohm' at the top. On the right side, there is a resistor labeled '10 ohm'. At the bottom, there is another resistor labeled '10 ohm'. The circuit is closed, forming a single loop.</p>	1
13	1 mark for identifying both, Switch 1 and Switch 2	1
14	(a) The resistance of the bulb increases as the temperature increases.	1
	(b) The current when the bulb is glowing at its full brightness = 0.5 A Power = $V \times I = 200 \times 0.5 = 100 \text{ W}$	1
15	(a) A very low current flows through the tester.	1
	(b) the resistor	1