

JEE-Main-24-01-2023 (Memory Based) [Paper-2]

Physics

Question: Identify the logic gate

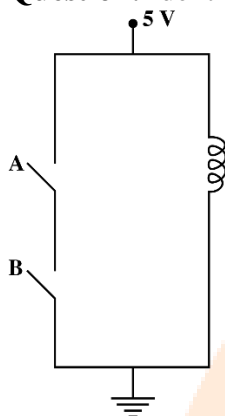

Options:

- (a) OR
- (b) AND
- (c) NAND
- (d) XOR

Answer: (c)

Solution: The bulb will glow all the times unless both switches are on, in which case battery will be grounded and no current will be going through the bulb and it will be off. So this circuit represents the working of a NAND gate.

Question: If $\gamma_1 = \frac{C_P}{C_V}$ for monatomic gas and $\gamma_2 = \frac{C_P}{C_V}$ for diatomic gas then, find $\frac{\gamma_1}{\gamma_2} = ?$

Options:

- (a) $\frac{25}{16}$
- (b) $\frac{25}{21}$
- (c) $\frac{21}{25}$
- (d) $\frac{49}{45}$

Answer: (b)

Solution:

$$\gamma_1 = \frac{5}{3}$$

$$\gamma_2 = \frac{7}{5}$$

$$\therefore \frac{\gamma_1}{\gamma_2} = \frac{\frac{5}{3}}{\frac{7}{5}} = \frac{25}{21}$$

Question: If length of wire on stretching is increased by 20% what is percentage increase in resistance

Options:

- (a) 40
- (b) 44
- (c) 20
- (d) 60

Answer: (b)

Solution:

Suppose original length = L, Area of cross-section = A, radius of wire = r and Resistance = R
Since the wire is the same, the resistivity ρ will be the same.

After the increase in length, let us take new length = L', radius of wire = r' and new resistance = R'

L' = 120 L/100 = 6L/5 (since there is 20% increase)

The volume of the wire remains the same (given).

So, Volume of Original Wire = volume of new wire

$$\pi r^2 L = \pi r'^2 L'$$

$$r^2 L = r'^2 L'$$

$$r'^2 = r^2 L / L' r'^2$$

$$= 5r^2 / 6$$

$$\text{Increase in resistance} = \frac{\frac{\rho L'}{A'} - \frac{\rho L}{A}}{\frac{\rho L}{A}} \times 100$$

$$\begin{aligned}
 &= \frac{6 \times 6 \rho L}{5 \times 5 \pi r^2} - \frac{\rho L}{\pi r^2} \times 100 \\
 &= \frac{\rho L}{\pi r^2} \times 100 \\
 &= \frac{36 \rho L}{25 \pi r^2} - \frac{\rho L}{\pi r^2} \times 100 \\
 &= \frac{\rho L}{\pi r^2} \times 100 \\
 &= \frac{36 \rho L - 25 \rho L}{25 \pi r^2} \times 100 \\
 &= \frac{\rho L}{\pi r^2} \times 100 \\
 &= \frac{11 \rho L}{25 \pi r^2} \times \frac{\pi r^2}{\rho L} \times 100 = 44\%
 \end{aligned}$$

Thus, the increase in length is 44%.

Question: A conducting rod is rotated in uniform magnetic field as shown below. Find EMF induced

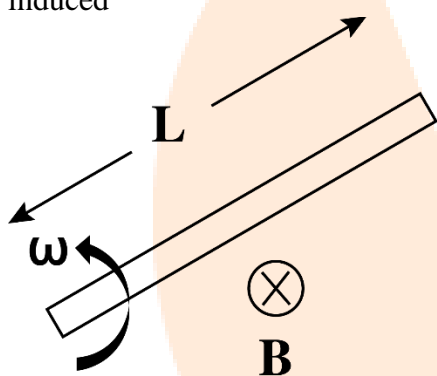

Options:

- (a) $\frac{1}{2} B \omega L^2$
- (b) $B \omega L^2$
- (c) $\frac{3}{2} B \omega L^2$
- (d) $2 B \omega L^2$

Answer: (a)

Solution:

Consider an infinitesimally small length of rod at a distance \$x\$ from the center of the circular path.

The emf induced across this element $d\mathcal{E} = Bv(dx)$

$$d\mathcal{E} = B(x\omega)(dx) = B\omega x dx$$

Thus the net EMF induced $\mathcal{E} = \int_0^L B\omega x dx$

$$\therefore \mathcal{E} = Bw \int_0^l x dx = Bw \times \frac{x^2}{2} \Big|_0^l$$

$$\Rightarrow \mathcal{E} = Bw \times \frac{(l^2 - 0)}{2} = \frac{Bl\omega}{2}$$

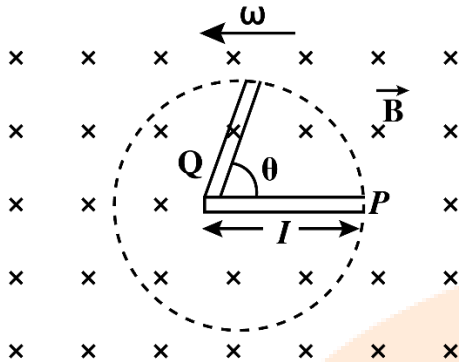

Question: $E = E_0 \sin(\omega t + kx)$ and $B = B_0 \sin(\omega t + kx)$ represent electric & magnetic fields of an EM wave then relation between E_0 & B_0 is

Options:

- (a) $E_0 k = B_0 \omega$
- (b) $E_0 \omega = B_0 k$
- (c) $E_0 B_0 = \omega k$
- (d) None of the above

Answer: (a)

Solution:

$$\frac{E_0}{B_0} = c, \text{ also } k = \frac{2\pi}{\lambda} \text{ and } \omega = 2\pi\nu$$

$$\Rightarrow \frac{E_0}{B_0} = \frac{\omega}{k}$$

$$E_0 k = B_0 \omega$$

Question: A nucleus X of atomic mass 240 releases 200 MeV of energy when it undergoes fission. How much energy will be released by 120 grams of X ?

Options:

- (a) 9.6×10^{12} joules
- (b) 7.6×10^{12} joules
- (c) 12.7×10^{12} joules
- (d) 14.7×10^{12} joules

Answer: (a)

Solution:

$$120 \text{ grams} = \frac{1}{2} \text{ moles}$$

Energy released by 1 atom = 200 MeV

$$\therefore \text{Energy released by } \frac{1}{2} \text{ mole}$$

$$= \frac{6.023 \times 10^{23}}{2} \times 200 \times 10^6 \times 1.6 \times 10^{-19} \text{ joules}$$

$$= 9.636 \times 10^{12} = 9.6 \times 10^{12}$$

Question: A biconvex lens made of glass ($\mu = 1.5$) in air has focal length 18 cm. Find its focal length in water ($\mu = 4/3$)

Options:

- (a) 36 cm
- (b) 72 cm
- (c) 18 cm
- (d) None of these

Answer: (b)

Solution:

Focal length in air:

$$\frac{1}{f_1} = (\mu_g - 1) \left(\frac{1}{R_1} - \frac{1}{R_2} \right)$$

Focal length in water:

$$\frac{1}{f_2} = (\mu_g - 1) \left(\frac{1}{R_1} - \frac{1}{R_2} \right)$$

$$\therefore \frac{f_2}{f_1} = \frac{(\mu_g - 1)}{(\mu_g - 1)} = \frac{1.5 - 1}{\left(\frac{1.5}{4/3}\right) - 1} = \frac{0.5}{(0.5/4)} = 4$$

$$\therefore f_2 = f_1 \times 4 = 72 \text{ cm}$$

Question: $f \propto r^a \rho^b T^c$; f = frequency, ρ = Density, T = Surface tension. Find a, b, c.

Options:

- (a) $a = -3/2$, $b = -1/2$, $c = 1/2$
- (b) $a = -1/2$, $b = 1/2$, $c = 1/2$
- (c) $a = -3/2$, $b = -1/2$, $c = 3/2$
- (d) $a = -3/2$, $b = -5/2$, $c = 1/2$

Answer: (a)

Solution:

$$T^{-1} \propto L^a [ML^{-3}]^b [MT^{-2}]^c$$

$$T^{-1} \propto L^{a-3b} M^{b+c} T^{-2c}$$

$$-1 = -2c; c = \frac{1}{2}$$

$$0 = b + c \Rightarrow b = -\frac{1}{2}$$

$$0 = a - 3b$$

$$a = \frac{-3}{2}$$

Question: Two concentric semirings having linear charge density λ are placed as shown. Find potential at center.

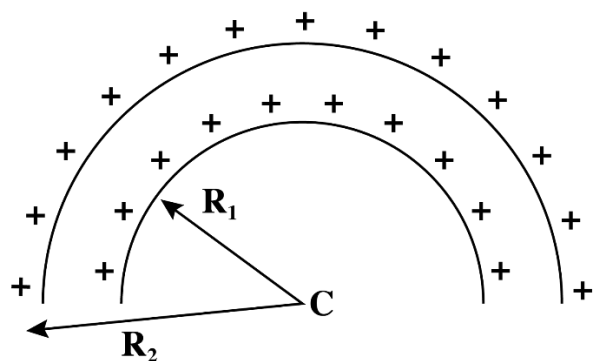

Options:

- (a) $\frac{\lambda}{\epsilon_0}$
- (b) $\frac{\lambda}{2\epsilon_0}$
- (c) $\frac{2\lambda}{\epsilon_0}$
- (d) None

Answer: (c)

Solution: Potential at center of a semi-circular = $\frac{\lambda}{4\epsilon_0}$

$$\text{Potential due to two arcs} = \frac{2\lambda}{4\epsilon_0} = \frac{\lambda}{2\epsilon_0}$$

Question: 1 gram of liquid vaporizer at pressure of 3×10^5 Pascal and its volume increases by 1200 cm^3 . 10% of the heat supplied is used to do work then find the increase in internal energy in joules

Options:

- (a) 3240 J
- (b) 3600 J
- (c) 360 J
- (d) 3000 J

Answer: (a)

Solution:

$$W = P\Delta V$$

$$= 3 \times 10^5 \times 1200 \times 10^{-6}$$

$$= 360 \text{ joules}$$

$$\text{Now } Q = \Delta U + W$$

$$W = .1Q$$

$$\Rightarrow \Delta U = .9Q$$

$$\Delta U = 9W$$

$$= 9 \times 360 = 3240$$

Question: The distance between sun & earth is approx. 1.5×10^8 km. Then the distance of a planet from SUN whose time period of revolution is around 2.83 years is

Options:

- (a) 9×10^8 km
- (b) 3×10^8 km
- (c) 27×10^8 km
- (d) 0.75×10^8 km

Answer: (b)

Solution:

$$T^2 \propto R^3$$

$$T_1 = 1 \text{ year}$$

$$T^2 = \lambda R^3$$

$$R_1 = 1.5 \times 10^8 \text{ km}$$

$$T_2 = 2.83 \text{ year}$$

$$\frac{T_2^2}{T_1^2} = \frac{R_2^3}{R_1^3}$$

$$R_2 = ?$$

$$2.83 \times 2.83 = \left(\frac{R_2}{R_1} \right)^3$$

$$\frac{R_2}{R_1} = (8)^{1/3}$$

$$R_2 = 2R_1$$

$$= 3 \times 10^8 \text{ km}$$

Question: For an isothermal process such that $T_1 > T_2 > T_3$ which represents the correct pV graph.

Options:

(a)

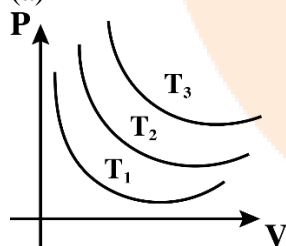

(b)

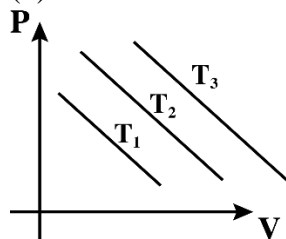

(c)

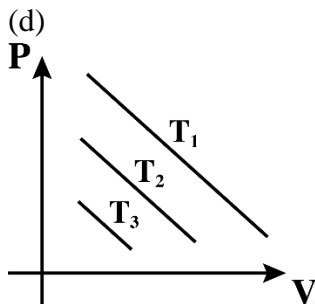
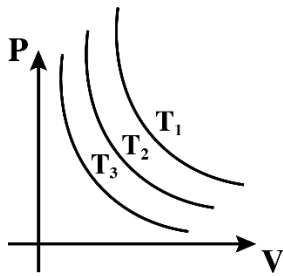

Answer: (c)

Solution:

More Temp. means curve will be higher up on P-V diagram.

Question: $R_V = 400 \Omega$

Find reading of voltmeter.

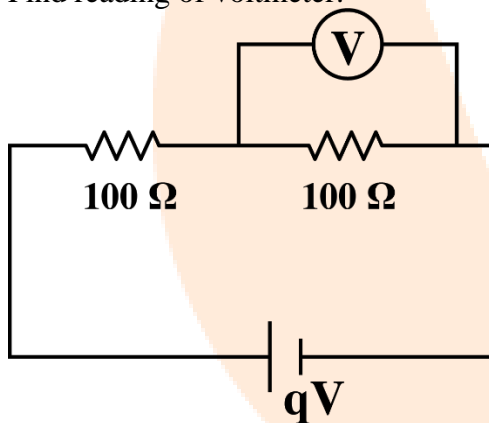

Options:

- (a) 5V
- (b) 3V
- (c) 4V
- (d) 6V

Answer: (c)

Solution:

$$R_{\text{net}} = \frac{400 \times 100}{400 + 100} + 100 = 180 \Omega$$

$$i = \frac{9}{180} = \frac{1}{20} \text{ A}$$

$$\text{Voltage across first resistance} = 100 \times \frac{1}{20} = 5\text{V}$$

$$\text{Reading of voltmeter} = 9 - 5 = 4\text{V}$$

Question: Statement 1: acceleration due to gravity decreases if we go at height “h” & at depth “d”.

Statement 2: Acceleration due to gravity at height h & at depth d is same if h = d.

Options:

- (a) 1-True, 2-False
- (b) 1-True, 2-True
- (c) 1- False, 2-True
- (d) 1- False, 2-False

Answer: (a)

Solution:

$$g_n = g \left(1 - \frac{2h}{R} \right) \& \ g_d = g \left(1 - \frac{d}{R} \right)$$

$$\therefore g_h = g_d \text{ if } d = 2h$$

Question: If electron, proton & α -Particle are accelerated through same P.D, then correct order of these de-Broglie wavelength is

Options:

- (a) $\lambda_p > \lambda_e > \lambda_\alpha$
- (b) $\lambda_\alpha > \lambda_p > \lambda_e$
- (c) $\lambda_\alpha < \lambda_p < \lambda_e$
- (d) $\lambda_e = \lambda_p < \lambda_\alpha$

Answer: (c)

Solution:

We know that de-Broglie’s wavelength is given by

$$\lambda = \frac{h}{p} = \frac{h}{mv} = \frac{h}{\sqrt{2mKE}}$$

$$\text{If K.E. same then } \lambda \propto \frac{1}{\sqrt{m}} \Rightarrow m \uparrow \lambda \downarrow$$

the order of mass of electron, proton and alpha particle is $\alpha > p > e^-$ hence, order of de-Broglie's wavelength is $\lambda_\alpha < \lambda_p < \lambda_{e^-}$

Question: A right angled triangle has current of 2A. The edge length are shown in the diagram. Magnetic field is acting in the plane of the triangle. The magnetic force acting on wire AB is

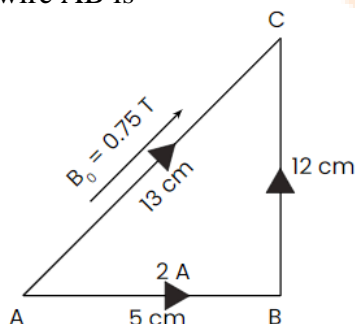

Options:

- (a) 5/130 N
- (b) 15/2 N
- (c) 3/40 N
- (d) 9/130 N

Answer: (d)

Solution:

$$\begin{aligned}\vec{F} &= I B \sin \theta \\ &= 0.75(5 \times 10^2) \times (2) \left(\frac{12}{13} \right) \\ &= \frac{9}{130} \text{ N}\end{aligned}$$

Question: Assertion (A) : Steel is used to build big structures.

Reason (R) : Steel has more elastic modulus as compared to other materials.

Options:

- (a) Both A and R are true and R is the correct explanation of A
- (b) Both A and R are true but R is not the correct explanation of A
- (c) A is true but R is false
- (d) Both A and R are false

Answer: (a)

Solution:

Since higher elastic modulus is desirable for a structure to be more rigid.

Question: The velocity-Time graph of a body moving along straight line is given as shown.

The ratio of displacement and distance is

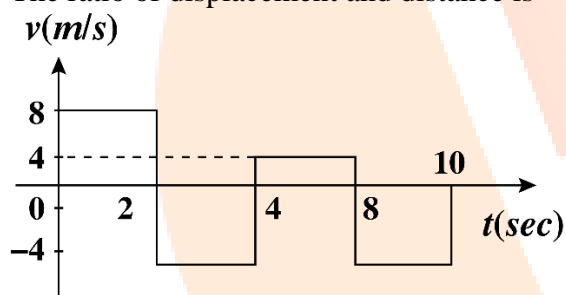

Options:

- (a) 1 : 1
- (b) 1 : 2
- (c) 1 : 3
- (d) 1 : 4

Answer: (c)

Solution:

Displacement = Net area

Distance = Total area

Displacement = $36 - 16 = 16$

Distance = $32 + 16 = 48$

\therefore Ratio = 1 : 3

JEE-Main-24-01-2023 (Memory Based)
[Paper-2]

Chemistry

Question: Conductometric titration graph of Benzoic acid and NaOH

Options:

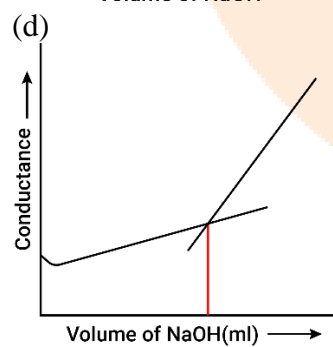
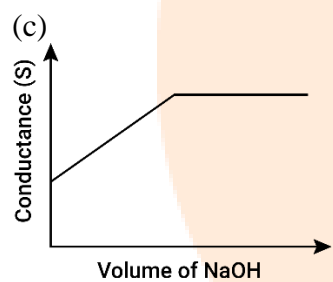
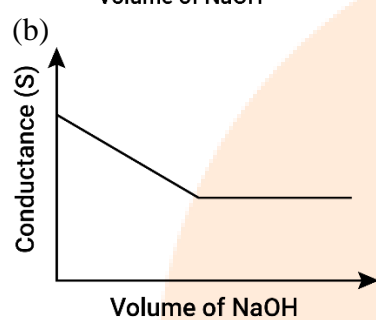
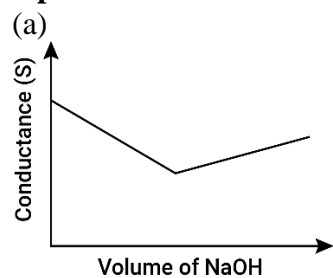

Answer: (d)

Solution:

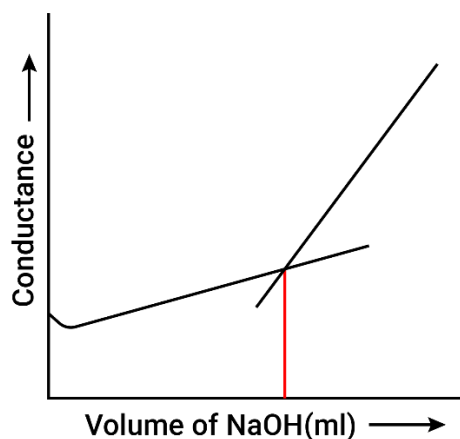

Question: s-subshell electrons in univalent species of having proton 55

Options:

- (a) 10
- (b) 12
- (c) 8
- (d) 11

Answer: (a)

Solution: $1s^2 2s^2 2p^6 3s^2 3p^6 3d^{10} 4s^2 4p^6 4d^{10} 5s^2 5p^6$, 10 electrons
s-subshell has 10 electrons in Cs +ve ion

Question: The number of unpaired electrons in the following molecular orbital
 N_2, N_2^+, O_2, O_2^+

Options:

- (a) 0, 1, 2, 1
- (b) 0, 2, 1, 0
- (c) 1, 2, 0, 1
- (d) 1, 0, 2, 1

Answer: (a)

Solution: $N_2 = 0$

$N_2^+ = 1$

$O_2 = 2$

$O_2^+ = 1$

Question: The oxidation state of the most electronegative element in the products of the reaction:

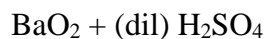

Options:

- (a) -1
- (b) -2
- (c) 0
- (d) +1

Answer: (b)

Solution: $BaO_2 \cdot 8H_2O(s) + H_2SO_4(aq) \rightarrow BaSO_4(s) + H_2O_2(aq) + 8H_2O(l)$

Question: Valine and proline can form how many peptide bonds

Options:

- (a) 1
- (b) 2
- (c) 3
- (d) 0

Answer: (a)

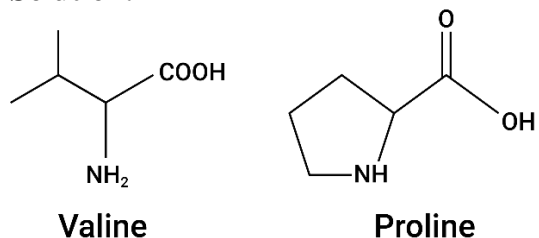

Solution:

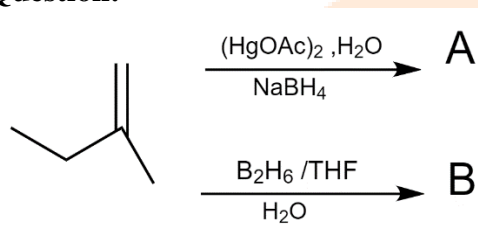

Question:

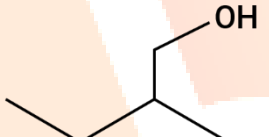
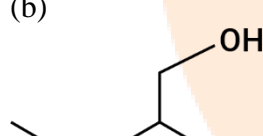

Options:

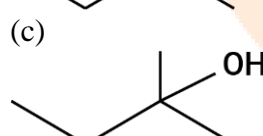
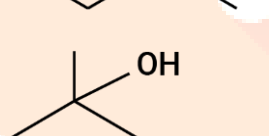
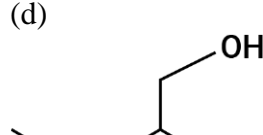
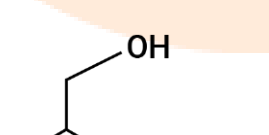
- (a)  , 
- (b)  , 
- (c)  , 
- (d)  , 

Answer: (a)

Solution:

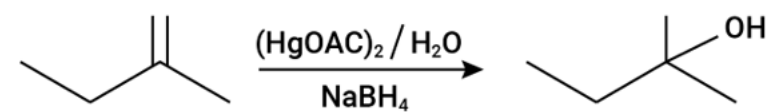

Follows M.K.R

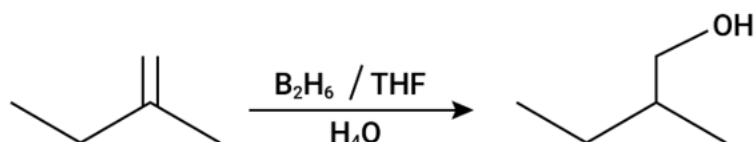

Anti Markovnikov's Rule

Question: Sum of π electrons in pyrosulphuric acid and peroxodisulphuric acid.

Options:

- (a) 16
- (b) 8
- (c) 18
- (d) 10

Answer: (a)

Solution:

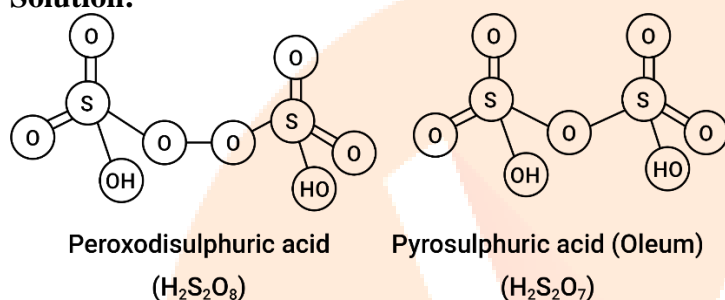

Question: In which of the following metal extraction, oxidation and reduction process both are involved?

Options:

- (a) Au
- (b) Cu
- (c) Fe
- (d) Al

Answer: (a)

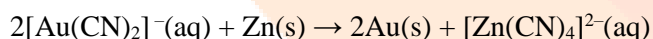
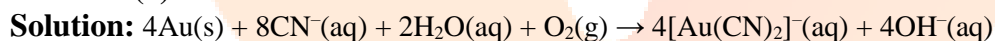

Question: Match Column I with Column II.

Column I	Column II
(A) Antifertility	(i) Salvarsan
(B) Tranquilizer	(ii) Norethindrone
(C) Antihistamine	(iii) Meprobamate
(D) Antibiotic	(iv) Seldane

Options:

- (a) A – i, B – ii, C – iii, D – iv
- (b) A – i, B – iii, C – iv, D – ii
- (c) A – i, B – iii, C – ii, D – iv
- (d) A – ii, B – iii, C – i, D – iv

Answer: (b)

Solution:

Antifertility – Salvarsan

Tranquilizer – Meprobamate
Antihistamine – Norethindrone
Antibiotic – Seldane

Question: Which statement is correct?

Options:

- (a) Humans require more food than air
- (b) Humans require more air than food
- (c) Humans need air 100 times more than food
- (d) Humans need air 15 times more than food

Answer: (d)

Solution: An average human being requires nearly 12-15 times more air than the food.

Question: Magnetic property and hybridization in $[\text{Co}(\text{NH}_3)_6]^{3+}$

Options:

- (a) 0, dsp^2
- (b) 0, d^2sp^3
- (c) 0, sp^3d^2
- (d) 1, d^2sp^3

Answer: (b)

Solution:

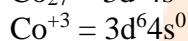
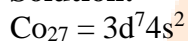

$\mu = 0$, d^2sp^3 , hybridization

Question: pKa of lactic acid is 4. Find the pH of 0.005 M calcium lactate at 27°C is:

Options:

- (a) 7.849
- (b) 5.849
- (c) 3.845
- (d) 8.849

Answer: (a)

Solution:

$$pK_a = 4, C = 5 \times 10^{-3}$$

Calcium lactate pH = ?

Salt of SB + WA

$$pH = 7 + \frac{1}{2} pK_a + \frac{1}{2} \log C$$

$$= 7 + \frac{4}{2} + \frac{1}{2} \log(5 \times 10^{-3})$$

$$= 7 + 2 + (-1.15)$$

$$= 7.849$$

Question: α - particle, proton and electron have same kinetic energy. Select correct order of de-Broglie wavelength.

Options:

(a) $\lambda_p = \lambda_\alpha = \lambda_e$

(b) $\lambda_e > \lambda_p > \lambda_\alpha$

(c) $\lambda_\alpha > \lambda_e > \lambda_p$

(d) $\lambda_p > \lambda_e > \lambda_\alpha$

Answer: (b)

Solution:

$$\lambda \propto \frac{1}{\sqrt{m}} \quad m_\alpha > m_p > m_e$$

$$\therefore \lambda_\alpha > \lambda_p > \lambda_e$$

Question: How many of the following concentration terms are temperature independent? Mole fraction, mass percent (%w/w), Molarity (M), Molality (m), ppm, volume percent (% V/V)

Options:

(a) 1

(b) 2

(c) 3

(d) 4

Answer: (d)

Solution: Mole fraction, mass percent (% w/w), Molality (m), ppm.

Question: $\text{K}_2\text{Cr}_2\text{O}_7 + \text{A} \rightarrow \text{Green colour}$

Options:

(a) Hydrogen sulphide

(b) SO_2

(c) SO_3

(d) CO_2

Answer: (b)

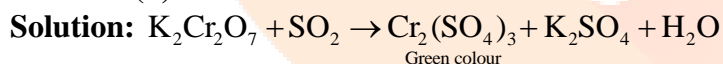

JEE-Main-24-01-2023 (Memory Based)
[Paper-2]

Mathematics

Question: $\int_{\frac{3\sqrt{2}}{4}}^{\frac{3\sqrt{3}}{4}} \frac{48}{\sqrt{9-4x^2}} dx$

Answer: 2π

Solution:

Given, $\int_{\frac{3\sqrt{2}}{4}}^{\frac{3\sqrt{3}}{4}} \frac{48}{\sqrt{9-4x^2}} dx$

$$48 \int_{\frac{3\sqrt{2}}{4}}^{\frac{3\sqrt{3}}{4}} \frac{dx}{\sqrt{(3)^2 - (2x)^2}} = \frac{48}{2} \sin^{-1} \frac{2x}{3} \Big|_{\frac{3\sqrt{2}}{4}}^{\frac{3\sqrt{3}}{4}}$$

$$24 \left\{ \sin^{-1} \frac{3\sqrt{3}}{3} - \sin^{-1} \frac{3\sqrt{2}}{3} \right\}$$

$$= 24 \left\{ \sin^{-1} \frac{\sqrt{3}}{2} - \sin^{-1} \frac{1}{\sqrt{2}} \right\}$$

$$= 24 \left\{ \frac{\pi}{3} - \frac{\pi}{4} \right\} = 24 \times \frac{\pi}{12}$$

$$= 2\pi$$

Question: If $\frac{1^3 + 2^3 + 3^3 + \dots + n \text{ terms}}{1 \times 3 + 2 \times 5 + 3 \times 7 + \dots + n \text{ terms}} = \frac{9}{5}$, then $n = ?$

Answer: 25.00

Solution:

$$\frac{1^3 + 2^3 + 3^3 + \dots + n \text{ terms}}{1 \times 3 + 2 \times 5 + 3 \times 7 + \dots + n \text{ terms}} = \frac{9}{5}$$

$$\frac{n^2(n+1)^2}{4\sum_{r=1}^n r(2r+1)} = \frac{n^2(n+1)^2}{4\left[\frac{2n(n+1)(2n+1)}{6} + \frac{n(n+1)}{2}\right]} = \frac{9}{5}$$

$$\frac{n(n+1)}{4\left(\frac{(2n+1)}{3} + \frac{1}{2}\right)} = \frac{9}{5}$$

$$5n^2 + 5n = 9\left[\frac{4(2n+1)}{3} + 2\right]$$

$$5n^2 + 5n = 24n + 12 + 18$$

$$5n^2 - 19n - 30 = 0$$

$$\frac{n^2(n+1)^2}{4\left[\frac{n(n+1)(2n+1)}{3} + \frac{n(n+1)}{2}\right]} = \frac{9}{5}$$

$$\frac{n(n+1)}{4\left(\frac{2n+1}{3} + \frac{1}{2}\right)} = \frac{n(n+1)}{\left[\frac{4n+5}{3}\right]} = \frac{9}{5}$$

$$5n(n+1) = 6(4n+5)$$

$$5n^2 + 5n = 24n + 30$$

$$5n^2 - 19n - 30 = 0$$

$$n = \frac{19 \pm \sqrt{361 + 600}}{2(5)} = \frac{19 \pm 31}{10}$$

$$n = 25$$

Question: $(x-4)^2 + (y-5)^2 = 4$ is given. Locus of mid point of chord that subtends angle

θ_i at centre is r_i . If $r_1^2 = r_2^2 + r_3^2$ and $\theta_1 = \frac{\pi}{3}$, $\theta_2 = \frac{2\pi}{3}$ then $\theta_3 =$ is equal to

Options:

- (a)
- (b)
- (c)
- (d)

Answer: ()

Solution:

$$r_1 = 2 \cos\left(\frac{\theta_1}{2}\right) = \frac{2\sqrt{3}}{2} = \sqrt{3}$$

$$r_2 = 2 \cos\left(\frac{\theta_2}{2}\right) = 2 \frac{1}{2} = 1$$

$$r_3^2 = 3 - 1$$

$$r_3 = \sqrt{2} = 2 \cos\left(\frac{\theta_3}{2}\right)$$

$$\cos\left(\frac{\theta_3}{2}\right) = \frac{1}{\sqrt{2}}$$

$$\frac{\theta_3}{2} = \frac{\pi}{4}$$

$$\theta_3 = \frac{\pi}{2}$$

Question: If area bounded by $y^2 - 4y = -x$ & $x + y = 0$ is A then $6A$ is

Answer: 125.00

Solution:

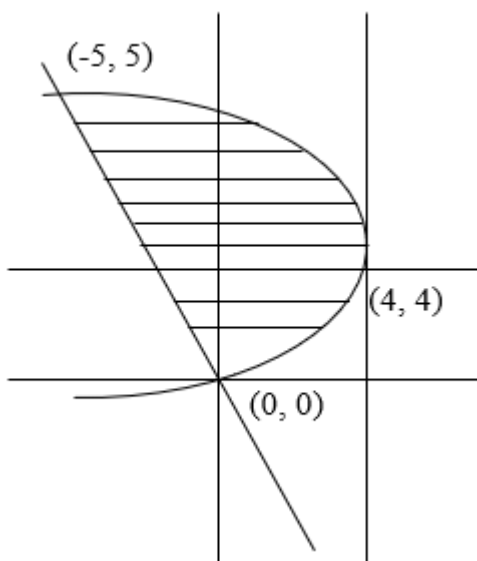

Given lines $y^2 - 4y = -x$ and $x + y = 0$

$$y^2 - 4y + 4 = -x + 4$$

$$(y - 2)^2 = -(x - 4)$$

$$y^2 = -x$$

Substituting x in place of y in $y^2 - 4y = -x$

$$x^2 + 4x = -x$$

$$x^2 + 5x = 0$$

$$x(x+5)=0$$

$$A = \int_0^5 (4y - y^2) - (-y) dy$$

$$= \int_0^5 5y - y^2 \cdot dy = \left. \frac{5y^2}{2} - \frac{y^3}{3} \right|_0^5$$

$$= \frac{125}{2} - \frac{125}{3}$$

$$= \frac{375 - 250}{6}$$

$$= \frac{125}{6}$$

$$6A = 125$$

Question: If $\lim_{x \rightarrow a} ([x-5] - [2x+2]) = 0$ then $a \in$ _____.

Answer: $[-7.5, -6.5]$

Solution:

$$\lim_{x \rightarrow a} [x] - [2x] = 7$$

$$\text{Let } a \in \left[I, I + \frac{1}{2} \right)$$

$$I - 2I = 7$$

$$\therefore I = -7 \quad a \in \left[-7, \frac{-13}{2} \right)$$

$$a \in \left[I + \frac{1}{2}, I + 1 \right]$$

$$I - (2I + 1) = 7$$

$$-I = 8$$

$$I = -8 \quad a \in \left[\frac{-15}{2}, -7 \right)$$

$$a \in \left[\frac{-15}{2}, \frac{-13}{2} \right)$$

Question: $f(x) = \frac{4^x}{4^x + 2}$

$$f\left(\frac{1}{2023}\right) + f\left(\frac{2}{2023}\right) + \dots + f\left(\frac{2022}{2023}\right) =$$

Answer: 1011.00

Solution:

$$f(x) + f(1-x) = \frac{4^x}{4^x + 2} + \frac{4^{1-x}}{4^{1-x} + 2} = 1$$

$$\therefore f\left(\frac{1}{2023}\right) + f\left(\frac{2022}{2023}\right) = 1$$

$$f\left(\frac{2}{2023}\right) + f\left(\frac{2021}{2023}\right) = 1$$

⋮

1011 such pairs each of whose sum = 1

Question: If $\binom{30}{C_1}^2 + 2\binom{30}{C_2}^2 + 3\binom{30}{C_3}^2 + \dots + 30\binom{30}{C_{30}}^2 = t \binom{60}{C_{30}}$, then $t = ?$

Answer: 15.00

Solution:

$$\binom{30}{C_1}^2 + 2\binom{30}{C_2}^2 + 3\binom{30}{C_3}^2 + \dots + 30\binom{30}{C_{30}}^2$$

$$= \sum_{r=1}^{30} r \binom{30}{C_r}^2$$

$$= \sum_{r=1}^{30} r \frac{30}{r} \binom{30}{C_r} \binom{29}{C_{r-1}}$$

$$= \binom{29}{C_{r-1}} \binom{30}{C_{30-r}}$$

$$= 30 \binom{59}{C_{29}} = t \binom{60}{C_{30}}$$

$$= 30 \binom{59}{C_{29}} = t \frac{60}{30} \binom{59}{C_{29}}$$

$$t = 15$$

Question: $\left(\frac{1 + \sin \frac{2\pi}{9} + i \cos \frac{2\pi}{9}}{1 + \sin \frac{2\pi}{9} - i \cos \frac{2\pi}{9}} \right)^3 = \text{---}$

Answer: $\frac{-\sqrt{3} + i}{2}$

Solution:

$$\left(\frac{1 + \operatorname{cis} \frac{5\pi}{18}}{1 + \operatorname{cis} \left(\frac{-5\pi}{18} \right)} \right)^3 = \left(\frac{2 \cos \frac{5\pi}{36} \operatorname{cis} \frac{5\pi}{36}}{2 \cos \frac{5\pi}{36} \operatorname{cis} \left(\frac{-5\pi}{36} \right)} \right)^3$$

$$= \left(cis \frac{5\pi}{18} \right)^3 = cis \frac{5\pi}{6}$$

$$= \cos \frac{5\pi}{6} + i \sin \frac{5\pi}{6} = \frac{-\sqrt{3} + i}{2}$$

Question: Six numbers are in A.P. Their mean is $\frac{19}{2}$. If $a_1 + a_3 = 10$ and σ^2 is the variance of these numbers, then $8\sigma^2 = \underline{\hspace{2cm}}$.

Answer: 210.00

Solution:

$$2a + 5d = 19$$

$$2a + 2d = 10$$

$$3d = 9$$

$$d = 3$$

$$\sigma^2 = \left(\frac{n^2 - 1}{12} \right) d^2 = \frac{35}{12} \times 9$$

$$8\sigma^2 = 8 \times \frac{35 \times 3}{4} = 210$$

Question: A is a 3×3 matrix such that $|\text{adj}(\text{adj}(\text{adj} A))| = 12^4$, then $|A^{-1} \text{adj} A| =$

Answer: ()

Solution:

$$|A|^{2^3} = 12^4$$

$$|A|^8 = 2^8 3^4$$

$$|A| = \pm 2\sqrt{3}$$

$$|A^{-1}| |\text{adj} A| = \frac{1}{|A|} |A|^2$$

$$|A| = \pm 2\sqrt{3}$$

Question: A 5×5 matrix is to be formed having elements 0 or 1 such that in every row & every column element '1' occurs exactly once.

Answer: 120.00

Solution:

In first column, 1 can be placed in any of the 5 places = 5

In second column, 1 can be placed in any of the 4 places = 4

In third column, 1 can be placed in any of the 3 places = 3

In fourth column, 1 can be placed in any of the 2 places = 2

In fifth column, 1 can be placed in any of the 1 place = 1

Total = 120

Question: We have the following digits: 3, 5, 6, 7, 8. How many numbers more than 7000 can be formed using the digits once only.

Answer: 168.00

Solution:

Number using all the 5 digits = $5! = 120$

Number using 4 digits

Case 1:

When 7 is fixed at 1000's place

$7_ _ _ = 24$ ways

Case II:

When 8 is fixed at 1000's place

$8_ _ _ = 24$ ways

Total number = $120 + 24 + 24 = 168$

Question: $S = \{ \tan(\pi \cos \theta) + \tan(\pi \sin \theta) = 0, \theta \in [0, 2\pi) \}$. $\sum_{\theta \in S} \sin^2 \left(\theta + \frac{\pi}{4} \right) = \underline{\hspace{2cm}}$

Answer: 4.00

Solution:

$$S = \tan(\pi \cos \theta) + \tan \pi(\sin \theta) = 0$$

$$\tan(\pi \cos \theta) = \tan(\pi - \pi \sin \theta)$$

$$\pi \cos \theta = n\pi + \pi - \pi \sin \theta$$

$$\cos \theta + \sin \theta = n + 1$$

$$n = 0, \sin \theta + \cos \theta = 1$$

$$\therefore \sin \left(\theta + \frac{\pi}{4} \right) = \frac{1}{\sqrt{2}} = 2 \text{ times}$$

$$n = -1, \sin \theta + \cos \theta = 0$$

$$\tan \theta = -1, \frac{3\pi}{4}, \frac{7\pi}{4}$$

$$\theta + \frac{\pi}{4} \Rightarrow \pi, 2\pi \Rightarrow \sin\left(\theta + \frac{\pi}{4}\right) = 0$$

$$n = -2, \sin \theta + \cos \theta = -1$$

$$\sin\left(\theta + \frac{\pi}{4}\right) = \frac{-1}{\sqrt{2}} = 2 \text{ times}$$

$$\frac{1}{2} + \frac{1}{2} + \frac{1}{2} + \frac{1}{2} = 4$$

Question: $f(x) = x^3 - f'(1)x^2 + f''(2)x + f'''(3)$

Options:

(a) $f(0) = f(1) + f(2)$

(b) $2f(0) = f(1) - f(3)$

(c)

(d)

Answer: ()

Solution:

$$f(x) = x^3 - f'(1)x^2 + f''(2)x + f'''(3)$$

Differentiate thrice & put $x = 3$

$$f'''(x) = 3!$$

$$\therefore f'''(3) = 6!$$

Let $f'(1) = a$ & $f''(2) = b$

$$f''(x) = 6x - 2f'(1)$$

$$x = 2 \Rightarrow b + 2a = 12$$

$$f'(x) = 3x^2 - 2f'(1)x + f''(2)$$

$$x = 1 \Rightarrow a = 3 - 2a + b$$

$$3a = 3 + b$$

$$a = 3 \text{ \& } b = 6$$

$$f(x) = x^3 - 3x^2 + 6x + 6$$

Question: The sum of the coefficients of first three terms in the expansion of $\left(x - \frac{3}{x^2}\right)^n$ is

376. The coefficient of x^4 is equal to

Options:

(a) 695

(b) 410

(c) 405

(d) 395

Answer: (c)

Solution:

$${}^n C_0 + {}^n C_1(-3) + {}^n C_2 \cdot 9 = 376$$

$$2 - 6n + \frac{n(n-1)}{2} \cdot 9 = 752$$

$$9n^2 - 15n - 750 = 0$$

$$3n^2 - 5n - 250 = 0$$

$$n = \frac{5 \pm 55}{6}$$

$$\begin{aligned} T_{r+1} &= {}^{10} C_r (x)^{10-r} \cdot \left(\frac{-3}{x^2}\right)^r \\ &= {}^{10} C_r \cdot (-3)^r (x)^{10-3r} \end{aligned}$$

$$\text{Coeff.} = {}^{10} C_2 \times (-3)^2$$

$$= \frac{10 \times 9}{2} \times 9$$

$$= 405$$

