

## JEE-Mains-25-01-2023 (Memory Based) [Morning Shift]

### Physics

**Question:** Find the de-Broglie wavelength when a charge is accelerated through potential  $2V$ , if it was  $\lambda_0$  when the charge was accelerated through potential 'V'.

**Options:**

- (a)  $\lambda_0/2$
- (b)  $\sqrt{2}\lambda_0$
- (c)  $2\lambda_0$
- (d)  $\lambda_0/\sqrt{2}$

**Answer: (d)**

**Solution:**

$$\lambda_0 = \frac{h}{\sqrt{2mqV}}$$

$$\lambda = \frac{h}{\sqrt{2mq(2v)}} = \frac{\lambda_0}{\sqrt{2}}$$

**Question:** Match the columns:

Physical Quantity	SI units
a. Pressure	i. $\text{Kg m s}^{-1}$
b. Impulse	ii. $\text{Kg m}^{-1} \text{s}^{-1}$
c. Coefficient of Viscosity	iii. $\text{Kg m}^2 \text{s}^{-1}$
d. Angular momentum	iv. $\text{Kg m}^{-1} \text{s}^{-2}$

**Options:**

- (a) a-ii, b-iii, c-iv, d-i
- (b) a-iv, b-i, c-ii, d-iii
- (c) a-i, b-iv, c-iii, d-ii
- (d) a-iii, b-ii, c-i, d-iv

**Answer: (b)**

**Solution:**

$$P = \frac{F}{A} = \frac{ma}{A} = \frac{\text{kg} \left( \frac{\text{m}}{\text{s}^2} \right)}{\text{m}^2} = \text{Kg m}^{-1} \text{s}^{-2}$$

$$I = \Delta p = \text{kg} \frac{\text{m}}{\text{s}} = \text{kg m s}^{-1}$$

$$\eta = \frac{F}{6\pi r v} = \frac{\text{Kg} \cdot \text{m} / \text{s}^2}{\text{m}^2 / \text{s}} = \text{Kg m}^{-1} \text{s}^{-1}$$

$$L = mvr = \text{kg} \frac{\text{m}^2}{\text{s}} = \text{kg} \cdot \text{m}^2 \text{s}^{-1}$$

**Question:** A ball of mass  $m = 100\text{ g}$  is kept in tunnel along diameter of earth. Find its time period of SHM.

**Options:**

- (a)  $2\pi\sqrt{Rg}$
- (b)  $\sqrt{4Rg}$
- (c)  $2\pi\sqrt{R/g}$
- (d)  $2\pi\sqrt{2R/g}$

**Answer:** (c)

**Solution:**

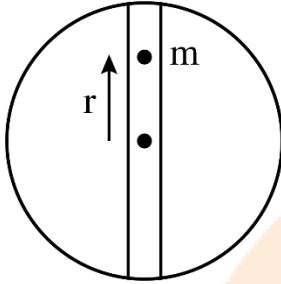

$$F = mg$$

$$= m \frac{GM}{R^3} r$$

$$T.P. = 2\pi \sqrt{\frac{m}{\frac{GMm}{R^3}}} = 2\pi \sqrt{\frac{R^3}{GM}} = 2\pi \sqrt{\frac{R}{g_{\text{surface}}}}$$

**Question:** In the diagram shown, a rod of mass  $2\text{ kg}$  is supported with a string attached as shown with a  $8\text{ kg}$  mass suspended from it. The wall support is fixed. Find the tension in the string. Take  $g = 10\text{ m/s}^2$

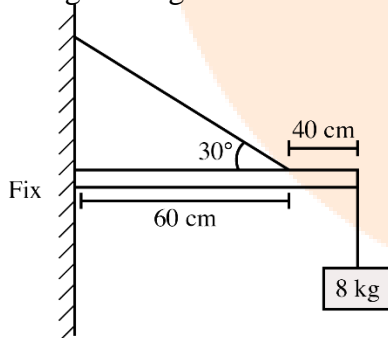

**Options:**

- (a)  $300\text{ N}$
- (b)  $150\text{ N}$
- (c)  $600\text{ N}$
- (d)  $900\text{ N}$

**Answer:** (a)

**Solution:**

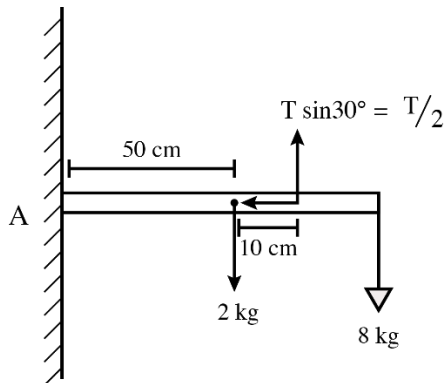

Torque about point A = 0

$$2g(0.5) - \left(\frac{T}{2}\right)(0.6) + 8g(1) = 0$$

$$9g = T(0.3)$$

$$T = 30g = 300 \text{ N}$$

**Question:** A Parallel plate capacitor of capacitance C, has plate area  $40 \text{ cm}^2$  and plate separation 5mm.

If a dielectric slab of  $K = 4$  and thickness 4mm is introduced between the plates, then the new Capacitance will be -

**Options:**

- (a) 10 C
- (b) 5 C
- (c) 15 C
- (d) 20 C

**Answer: (a)**

**Solution:**

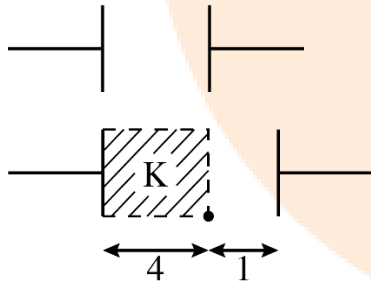

$$C = \frac{AG_0}{d} = \frac{AG_0}{5}$$

$$\frac{1}{C'} = \frac{1}{C_1} + \frac{1}{C_2} = \frac{d_1}{A\epsilon_0 K} + \frac{d_2}{A\epsilon_0}$$

$$= \frac{4}{A\epsilon_0(4)} + \frac{1}{A\epsilon_0} = \frac{1}{A\epsilon_0} + \frac{1}{A\epsilon_0} = \frac{2}{A\epsilon_0}$$

$$\left[ C' = \frac{A\epsilon_0}{2} = \frac{5C}{2} = 2.5C \right]$$

**Question:** A car is moving with a constant speed of 2 m/s in circle having radius R. A pendulum is suspended from the ceiling of the car. Find the angle made by the pendulum with the vertical. Take  $R = 8/15 \text{ m}$  &  $g = 10 \text{ m/s}^2$

**Options:**

- (a)  $30^\circ$
- (b)  $53^\circ$
- (c)  $37^\circ$
- (d)  $60^\circ$

**Answer: (c)**

**Solution:**

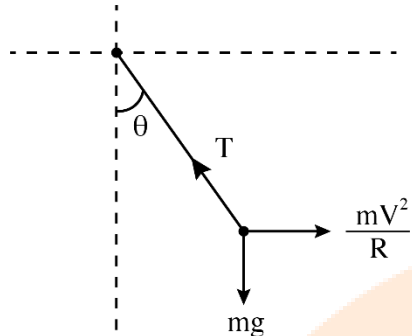

$$\tan \theta = \frac{v^2}{Rg} = \frac{(2)^2}{\left(\frac{8}{15}\right) \times 10} = \frac{3}{4} = 37^\circ$$

**Question:** An em wave is propagating along +z direction having electric field along positive y direction. Find direction of magnetic field?

**Options:**

- (a)  $\hat{i}$
- (b)  $-\hat{i}$
- (c)  $\hat{j}$
- (d)  $-\hat{j}$

**Answer: (b)**

**Solution:**

$$\hat{c} = \hat{E} \times \hat{B}$$

$$\hat{k} = \hat{j} \times \hat{B}$$

$$\therefore \hat{B} = -\hat{i}$$

**Question:** A carnot engine gives 50% efficiency for source temperature of 600 k. What should be source temperature if  $\eta = 70\%$  is required for same sink temperature.

**Options:**

- (a) 100 K
- (b) 700 K
- (c) 1000 K
- (d) 800 K

**Answer: (c)**

**Solution:**

$$\eta_1 = 0.5$$

$$0.5 = 1 - \frac{T_1}{T_2}$$

$$\frac{1}{2} = 1 - \frac{T_1}{600}$$

$$\Rightarrow T_1 = 300$$

$$\eta_2 = 70\% \text{ or } 0.7$$

$$\therefore 0.7 = 1 - \frac{300}{T_2'} \Rightarrow T_2' = 1000K$$

**Question:** If T is the temperature of a gas then RMS velocity of the gas molecule is proportional to

**Options:**

- (a)  $T^{1/2}$
- (b)  $T^{-1/2}$
- (c) T
- (d)  $T^2$

**Answer: (a)**

**Solution:**

$$V_{rms} = \sqrt{\frac{3RT}{M}}$$

$$\therefore V_{rms} \propto \sqrt{T}$$

**Question:** The period of pendulum at earth's surface is T. find the time period of the pendulum at distance (from center) which is twice the radius of earth.

**Options:**

- (a) T/4
- (b) 4T
- (c) T/2
- (d) 2T

**Answer: (d)**

**Solution:**

$$T = 2\pi \sqrt{\frac{l}{g}}$$

$$T' = 2\pi \sqrt{\frac{l}{g'}}$$

$$g' = \frac{GM}{(2R)^2} = \frac{GM}{4R^2} = \frac{g}{4}$$

$$\therefore T' = 2\pi \sqrt{\frac{l}{g/4}} = 2T$$

**Question:** A particle travels half of total distance with speed  $v_1$  and next half with speed  $v_2$  along a straight line. Find out the average speed of the particle?

**Options:**

(a)  $\frac{2v_1v_2}{v_1 + v_2}$

(b)  $\frac{2v_1v_2}{v_1 - v_2}$

(c)  $\frac{v_1 + v_2}{2v_1v_2}$

(d)  $\frac{v_1 - v_2}{2v_1v_2}$

**Answer: (a)**

**Solution:**

Suppose a particle travel “2x” distance linearly hence in time  $t_1$  he can travel “x” distance and in time  $t_2$  he can travel next “x” distance.

So from the definition of average speed which is equals to  $\frac{\text{total distance traveled}}{\text{total time taken}}$

$$= \frac{2x}{\frac{x}{v_1} + \frac{x}{v_2}} = \frac{2v_1v_2}{v_1 + v_2}$$

**Question:** Find the ratio of density of Helium nucleus & Calcium nucleus.

**Options:**

(a) 1 : 1

(b) 2 : 1

(c) 4 : 1

(d) 1 : 32

**Answer: (a)**

**Solution:**

$$\rho = \frac{\text{Atomic mass}}{\text{Nuclear vol.}} = \frac{M}{\frac{4}{3}\pi R^3}$$

$$R = R_0 A^{1/3}$$

$$\therefore \rho = \frac{\text{Atomic mass}}{\frac{4}{3}\pi (R_0)^3 A}$$

$$\rho_{CA} = \frac{40}{\frac{4}{3}\pi (R_0)^3 (40)}$$

$$\rho_{He} = \frac{4}{\frac{4}{3}\pi R_0^3 (4)}$$

$$\therefore \rho_{CA} : \rho_{He} = 1 : 1$$

**Question:** In a LCR series circuit the capacitance is C and angular frequency of AC is  $\omega$ . The self inductance of the inductor to be connected in the circuit for which the circuit has maximum current is

**Options:**

- (a)  $2/\omega^2 c$
- (b)  $1/2\omega^2 c$
- (c)  $1/\omega^2 c$
- (d) Data insufficient

**Answer: (c)**

**Solution:** For max. current

$$\omega = \frac{1}{\sqrt{LC}}$$

$$\therefore \omega^2 = \frac{1}{LC}$$

$$\therefore L = \frac{1}{\omega^2 c}$$

**Question:** The phase difference between two light waves is  $60^\circ$  and the distance between their source of origination is 10 nm. Find the velocity of light if frequency is 'f'.

**Solution:**

$$\frac{\Delta x}{\lambda} = \frac{\Delta \phi}{2\pi}$$

$$\Rightarrow \lambda = 10 \times \frac{2\pi}{\frac{\pi}{3}} = 60 \text{ nm}$$

$$v = f \lambda$$

$$v = 60 \times 10^{-9} f = 6 \times 10^{-8} f$$

**Question:** An LC oscillator has a frequency of  $\omega$ . If the inductance is increases to 2 times and capacitance 8 times, find the new value of  $\omega$ .

**Options:**

- (a)  $\omega/2$
- (b)  $2\omega$
- (c)  $\omega/4$
- (d)  $4\omega$

**Answer: (c)**

**Solution:**

$$\omega = \frac{1}{\sqrt{LC}}$$

$$\omega' = \frac{1}{\sqrt{2L \times 8C}} = \frac{1}{4\sqrt{LC}} = \frac{\omega}{4}$$

**Question:** If the half life of a radioactive material is 30 minutes. Find the time taken for 75% completion of process.

**Options:**

- (a) 60 min
- (b) 15 min
- (c) 75 min
- (d) 90 min

**Answer: (a)**

**Solution:**

$$N = N_0 e^{-\lambda t}$$

$$\frac{N_0}{2} = N_0 e^{-\lambda t_{1/2}}$$

$$\Rightarrow t_{1/2} = \frac{\log_e 2}{\lambda} \cdot \frac{\ln 2}{\lambda}$$

At 75% completion  $N = \frac{N_0}{4}$

$$\frac{N_0}{4} = N_0 e^{-\lambda t_{3/4}} \Rightarrow t_{3/4} = \frac{2 \log 2}{\lambda} = 2t_{1/2}$$

$$t_{3/4} = 60 \text{ min}$$

**Question:** Calculate the bandwidth of AM signal having  $f_c = 20 \text{ MHz}$  and  $f_m = 5 \text{ KHz}$ .

**Options:**

- (a) 5 kHz
- (b) 10 kHz
- (c) 20 kHz
- (d) 15 kHz

**Answer: (b)**

**Solution:**

$$\text{Bandwidth} = 2f_m = 10 \text{ kHz}$$

**Question:** Consider the following statements in relation to diode.

Assertion – Photo Diode is operated in Reverse Biased Mode.

Reason - Significant current flows through a PN Junction Diode when it is operated in reverse biased mode.

**Options:**

- (a) Assertion and Reason are correct, Reason is correct explanation of assertion
- (b) Assertion and Reason are correct, Reason is NOT a correct explanation of assertion
- (c) Assertion is Correct, Reason is incorrect
- (d) Assertion is incorrect, Reason is correct

**Answer: (b)**

**Solution:** Conceptual

**Question:** A solenoid has 1200 turns length 2m & carries 2A current. Find magnetic field at center.

**Answer:**  $48\pi \times 10^{-5}$

$$\text{Solution: } B = \mu_0 n I = \mu_0 \frac{N}{l} I = \mu_0 \frac{1200}{2} \times 2 = 48\pi \times 10^{-5}$$



**JEE-Main-25-01-2023 (Memory Based)**  
**[Morning Shift]**

**Chemistry**

**Question:** The number of lone pair of electrons present in oxygen in ozone.

**Options:**

- (a) 4
- (b) 6
- (c) 5
- (d) 12

**Answer: (b)**

**Solution:**

Ozone  $\Rightarrow$   $O_3$

6 lone pairs

Non bonded electrons 12 electrons

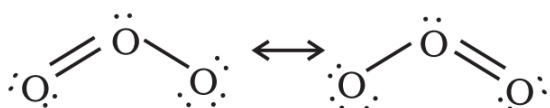

**Question:** Intermediate formed when phenol is prepared from cumene?

**Options:**

(a)

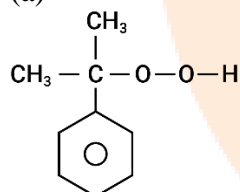

(b)

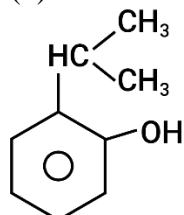

(c)

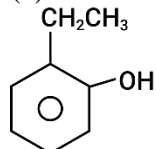

(d)

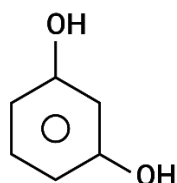

**Answer: (a)**

**Solution:**

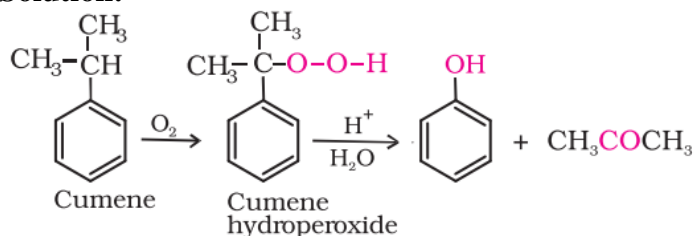

**Question:** Which of the following will give flame test?

**Options:**

- (a) Ba
- (b) Sr
- (c) Ca
- (d) All of the above

**Answer: (d)**

**Solution:** The electropositive character increases down the group from Be to Ba. Calcium, strontium and barium impart characteristic brick red, crimson and apple green colours respectively to the flame.

**Question:** What is the correct order of electron gain enthalpy of noble gases?

**Options:**

- (a)  $\text{Ne} > \text{Ar} = \text{Kr} > \text{Xe} > \text{He}$
- (b)  $\text{Ne} < \text{Ar} = \text{Kr} > \text{Xe} > \text{He}$
- (c)  $\text{Ne} < \text{Ar} = \text{Kr} < \text{Xe} < \text{He}$
- (d)  $\text{Ne} = \text{Ar} = \text{Kr} > \text{Xe} < \text{He}$

**Answer: (a)**

**Solution:**  $\text{Ne} > \text{Ar} = \text{Kr} > \text{Xe} > \text{He}$

**Question:** If X - atoms are present at alternate corners and at body centre of a cube and Y - atoms are present at  $1/3^{\text{rd}}$  of face centres then what will be the empirical formula?

**Options:**

- (a)  $\text{X}_{2.5}\text{Y}$
- (b)  $\text{X}_5\text{Y}_2$
- (c)  $\text{X}_{1.5}\text{Y}$
- (d)  $\text{X}_3\text{Y}_2$

**Answer: (d)**

**Solution:**

$$X = 4 \times \frac{1}{8} + 1 = \frac{3}{2}$$

$$Y = \frac{1}{3} \times 6 \times \frac{1}{2} = 1$$

X : Y

$\frac{3}{2} : 1$

$X_3Y_2$

**Question:** Reactions of  $\text{NO}_2$  in sunlight for photochemical smog

**Options:**

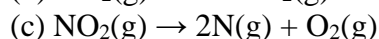
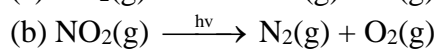
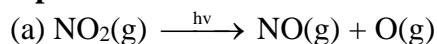

(d) None of the above

**Answer: (a)**

**Solution:** Formation of photochemical smog

When fossil fuels are burnt, a variety of pollutants are emitted into the earth's troposphere.

Two of the pollutants that are emitted are hydrocarbons (unburnt fuels) and nitric oxide (NO).

When these pollutants build up to sufficiently high levels, a chain reaction occurs from their interaction with sunlight in which NO is converted into nitrogen dioxide ( $\text{NO}_2$ ). This  $\text{NO}_2$  in turn absorbs energy from sunlight and breaks up into nitric oxide and free oxygen atom.

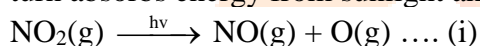

Oxygen atoms are very reactive and combine with the  $\text{O}_2$  in air to produce ozone.

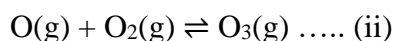

The ozone formed in the above reaction (ii) reacts rapidly with the  $\text{NO}(\text{g})$  formed in the reaction (i) to regenerate  $\text{NO}_2$ .  $\text{NO}_2$  is a brown gas and at sufficiently high levels can contribute to haze.



**Question:** Volume of 1.2 kg/l solution of monobasic acid ( $M = 24.2 \text{ g/mol}$ ) needed to neutralise 25 ml of 0.24 M NaOH.

**Options:**

(a) 149 ml

(b) 184 ml

(c) 121 ml

(d) 108 ml

**Answer: (c)**

**Solution:**

$$25 \times 0.24 = \frac{1.2 \times 1000 \times V}{24.2 \times 1000}$$

$$\frac{24.2 \times 6}{1.2} = V$$

$$V = 121 \text{ ml}$$

**Question:** Half life = 30 min. Find the time required for 75% completion of reaction.

**Options:**

(a) 15 min

(b) 5 min

(c) 20 min

(d) 60 min

**Answer: (d)**

**Solution:**

$$t_{1/2} = \frac{0.693}{K}$$

$$K = \frac{0.693}{30}$$

$$\frac{0.693}{30} = \frac{2.303}{t} \log \frac{100}{25}$$

$$t = \frac{2.303}{0.693} \times 30 \times 2 \times \log 2$$

$$t = 60 \text{ min}$$

**Question:** Which of the following are paramagnetic?

$V^{3+}$ ,  $Ti^{2+}$ ,  $Cr^{3+}$ ,  $Ni^{2+}$

number of paramagnetic species?

**Options:**

(a) 2

(b) 3

(c) 1

(d) 0

**Answer: (b)**

**Solution:**

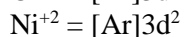
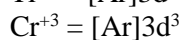
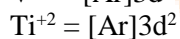
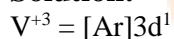

**Question:** Radius of 2<sup>nd</sup> orbit of  $Li^{2+}$  is x, then radius of 3<sup>rd</sup> orbit of  $Be^{3+}$  will be?

**Options:**

(a)  $\frac{27x}{16}$

(b)  $\frac{16x}{27}$

(c)  $\frac{4x}{3}$

(d)  $\frac{3x}{4}$

**Answer: (a)**

**Solution:**

$$\frac{r_{\text{Li}^{+2}}}{r_{\text{Be}^{+3}}} = \frac{\frac{a_0 n_{\text{Li}}^2}{Z_{\text{Li}}}}{\frac{a_0 n_{\text{Be}}^2}{Z_{\text{Be}}}}$$

$$\frac{x}{r_{\text{Be}^{+3}}} = \frac{\frac{(4)}{9}}{\frac{4}{9}}$$

$$\Rightarrow \frac{x}{r_{\text{Be}^{+3}}} = \frac{4 \times 4}{9 \times 3} = \frac{16}{27}$$

$$r_{\text{Be}^{+3}} = \frac{27x}{16}$$

**Question:**

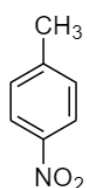

- (i) Bromination  
(ii) Reduction  
(iii) diazotisation  
(iv)  $\text{KMnO}_4$

**Options:**

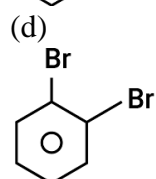
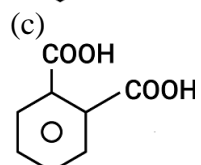
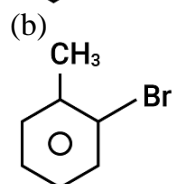
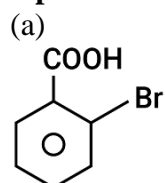

**Answer: (a)**

**Solution:**

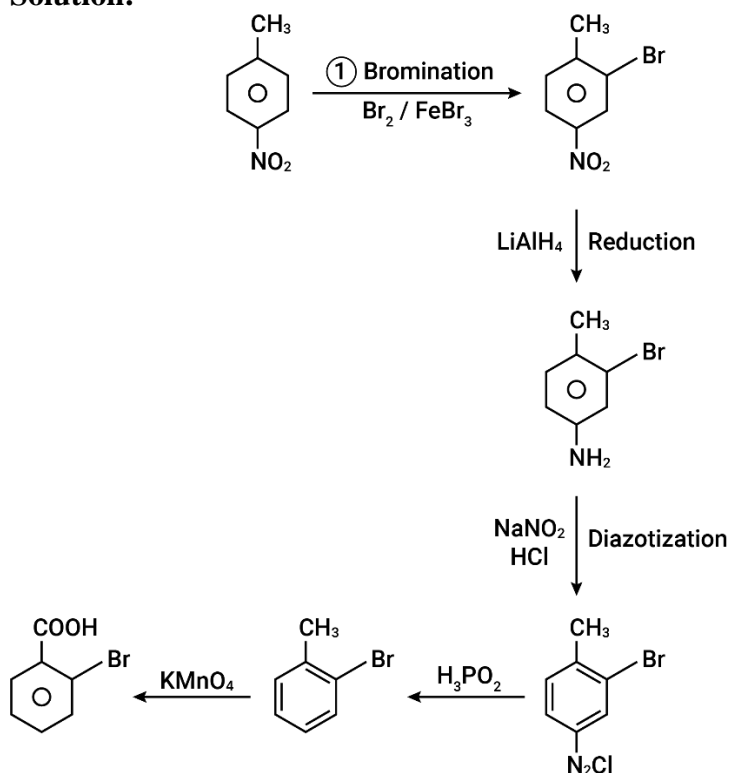

**Question:** Thionyl chloride on reaction with white phosphorous gives compound A. A on hydrolysis give compound B which is dibasic. Identify A and B

**Options:**

- (a) A- $\text{PCl}_5$ , B- $\text{H}_3\text{PO}_4$
- (b) A- $\text{P}_4\text{O}_{10}$ , B- $\text{H}_3\text{PO}_4$
- (c) A- $\text{POCl}_3$ , B- $\text{H}_3\text{PO}_4$
- (d) A- $\text{PCl}_3$ , B- $\text{H}_3\text{PO}_3$

**Answer: (d)**

**Solution:**

Preparation

It is obtained by passing dry chlorine over heated white phosphorus.

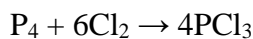

It is also obtained by the action of thionyl chloride with white phosphorus.



Properties

It is a colourless oily liquid and hydrolyses in the presence of moisture.

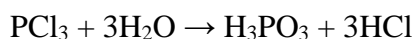

**Question:** Compare basic strength:



**Options:**

- (a)  $(\text{CH}_3)_2\text{NH} > \text{CH}_3\text{NH}_2 > (\text{CH}_3)_3\text{N} > \text{NH}_3$   
 (b)  $(\text{CH}_3)_2\text{NH} > \text{CH}_3\text{NH}_2 > \text{NH}_3 > (\text{CH}_3)_3\text{N}$   
 (c)  $\text{CH}_3\text{NH}_2 > (\text{CH}_3)_2\text{NH} > \text{NH}_3 > (\text{CH}_3)_3\text{N}$   
 (d)  $\text{NH}_3 > (\text{CH}_3)_2\text{NH} > \text{CH}_3\text{NH}_2 > (\text{CH}_3)_3\text{N}$

**Answer: (a)**

**Solution:** The order of basic strength in case of methyl substituted amines in aqueous solution is as follows:

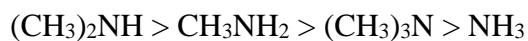

**Question:** Which of the following shows least reactivity towards nucleophilic substitution reaction?

**Options:**

(a)

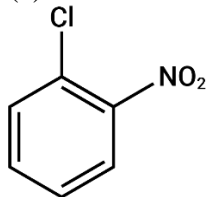

(b)

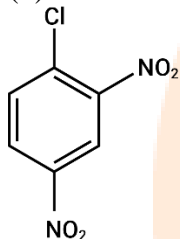

(c)

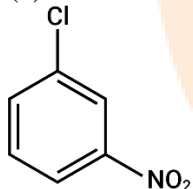

(d)

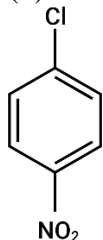

**Answer: (c)**

**Solution:**

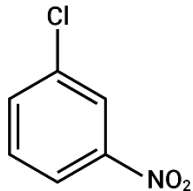

**Question:** Number of paramagnetic species in  $[\text{Ni}(\text{CN})_4]^{2-}$ ,  $[\text{NiCl}_4]^{2-}$ ,  $[\text{Fe}(\text{CN})_6]^{3-}$ ,  $[\text{Fe}(\text{CN})_6]^{4-}$ ,  $[\text{CuCl}_4]^{2-}$ ,  $[\text{Cu}(\text{CN})_4]^{3-}$ ,  $[\text{Cu}(\text{H}_2\text{O})_4]^{2+}$

**Options:**

- (a) 4
- (b) 3
- (c) 5
- (d) 6

**Answer: (a)**

**Solution:**  $[\text{NiCl}_4]^{2-}$ ,  $[\text{Fe}(\text{CN})_6]^{3-}$ ,  $[\text{CuCl}_4]^{2-}$ ,  $[\text{Cu}(\text{H}_2\text{O})_4]^{2+}$

**Question:**  $\text{Pt} | \text{H}_2 (1 \text{ atm}) | \text{H}^+ (1 \text{ M}) || \text{Fe}^{3+} | \text{Fe}^{2+}$

Find the ratio of concentration of  $\text{Fe}^{2+}$  to  $\text{Fe}^{3+}$

$E_{\text{cell}} = 0.712$  and  $E_{\text{cell}}^{\circ} = 0.771$

**Options:**

- (a) 2
- (b) 3
- (c) 4
- (d) 1

**Answer: (a)**

**Solution:**

$$E_{\text{cell}} = E_{\text{cell}}^{\circ} - \frac{0.059}{2} \log \frac{\text{Product}}{\text{Reactant}}$$

$$0.712 = 0.771 - \frac{0.059}{2} \log \frac{[\text{P}]}{[\text{R}]}$$

$$-0.059 = -\frac{0.059}{2} \log \frac{[\text{P}]}{[\text{R}]}$$

$$2 = \log \frac{[\text{P}]}{[\text{R}]}$$

**Question:** Identify the correct sequence of reagents for the following sequence

n-Heptane  $\rightarrow$  A  $\rightarrow$  B  $\rightarrow$  PhCOOH + PhCH<sub>2</sub>COOH

**Options:**

- (a)  $\text{Al}_2\text{O}_3/\text{Cr}_2\text{O}_3$ ,  $\text{CrO}_2\text{Cl}_2/\text{H}_3\text{O}^+$ , conc NaOH,  $\text{H}_3\text{O}^+$
- (b)  $\text{Al}_2\text{O}_3/\text{Cr}_2\text{O}_3$ ,  $\text{CrO}_2\text{Cl}_2/\text{H}_3\text{O}^+$ ,  $\text{H}_3\text{O}^+$ , conc NaOH
- (c)  $\text{CrO}_2\text{Cl}_2$ ,  $\text{Al}_2\text{O}_3$ , Conc. NaOH,  $\text{H}_3\text{O}^+$
- (d) Sn/HCl, Conc. NaOH,  $\text{CrO}_2\text{Cl}_2$ ,  $\text{HNO}_3$

**Answer: (a)**

**Solution:**

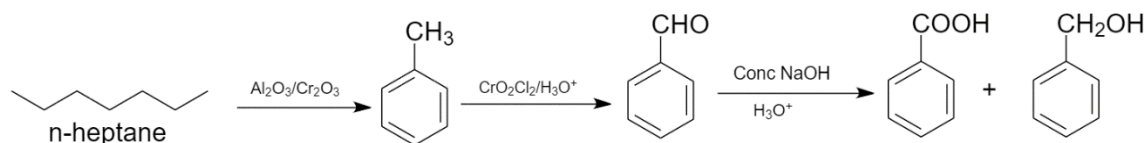



**JEE-Main-25-01-2023 (Memory Based)**  
**[Morning Shift]**

**Mathematics**

**Question:**  $(p \wedge \sim q) \rightarrow (p \rightarrow \sim q)$  is a:

**Options:**

- (a) Tautology
- (b) Fallacy
- (c) Equivalent to  $p \vee \sim q$
- (d) Equivalent to  $p \wedge \sim q$

**Answer: (a)**

**Solution:**

$$\begin{aligned} & (p \wedge \sim q) \rightarrow (p \rightarrow \sim q) \\ &= (p \wedge \sim q) \rightarrow (\sim p \vee \sim q) \\ &= \sim (p \wedge \sim q) \vee (\sim p \vee \sim q) \\ &= \sim p \vee q \vee (\sim p \vee \sim q) \\ &= \sim p \wedge T \\ &= T \end{aligned}$$

**Question:**  $\lim_{n \rightarrow \infty} \frac{1+2-3+4+5-6+\dots+(3n-2)+(3n-1)-3n}{\sqrt{2n^4+3n+1}-\sqrt{n^4+n+3}} = ?$

**Options:**

- (a)  $\frac{3(\sqrt{2}+1)}{2}$
- (b)  $\frac{2(\sqrt{2}+1)}{2}$
- (c)  $\frac{2}{3\sqrt{2}}$
- (d)  $2\sqrt{2}$

**Answer: (a)**

**Solution:**

For Numerator

$$\sum_{n=1}^{\infty} (3n-2) + (3n-1) - 3n$$

$$\begin{aligned}
 &= \sum 3n - 3 \\
 &= 3(\sum n - \sum 1) \\
 &= 3\left[\frac{n(n+1)}{2} - n\right] \\
 &= \frac{3}{2}[n^2 - n]
 \end{aligned}$$

Applying

$$\begin{aligned}
 &\frac{3}{2} \lim_{n \rightarrow \infty} \frac{n^2 - n}{\sqrt{2n^4 + 3n + 1} - \sqrt{n^4 + n + 3}} \\
 &\frac{3}{2} \lim_{n \rightarrow \infty} \frac{n^2 - n}{\sqrt{n^4 \left(2 + \frac{3}{n^3} + \frac{1}{n^4}\right)} - \sqrt{n^4 \left(1 + \frac{1}{n^3} + \frac{3}{n^4}\right)}} \\
 &\frac{3}{2} \lim_{n \rightarrow \infty} \frac{n^2 - n}{n^2 \left\{ \sqrt{\left(2 + \frac{3}{n^3} + \frac{1}{n^4}\right)} - \sqrt{\left(1 + \frac{1}{n^3} + \frac{3}{n^4}\right)} \right\}}
 \end{aligned}$$

$$\frac{3}{2} \left( \frac{1}{\sqrt{2}} - 1 \right) = \frac{3}{2} (\sqrt{2} + 1)$$

**Question:** If  $F(t) = \int \frac{2t}{(t^2+1)(t^2+3)} dt$ , then find  $F(4)$ , given that  $F(3) = \frac{\ln 5 - \ln 6}{2}$

**Answer:**  $\frac{1}{2} \ln \frac{17}{19}$

**Solution:**

$$\text{Given, } F(t) = \int \frac{2t}{(t^2+1)(t^2+3)} dt$$

Put  $t^2 = u$

$$f(t) = \int \frac{du}{(u+1)(u+3)}$$

$$\frac{1}{2} \int \frac{1}{u+1} - \frac{1}{u+3} du$$

$$F(t) = \frac{1}{2} \ln \left| \frac{t^2+1}{t^2+3} \right| + C$$

$$\text{Put } t = 3, \frac{\ln 5 - \ln 6}{2} = \frac{\ln 5 - \ln 6}{2} + C$$

$$C = 0$$

$$F(4) = \frac{1}{2} \ln \left| \frac{17}{19} \right| + 0$$

$$F(4) = \frac{1}{2} \ln \frac{17}{19}$$

**Question:** If  $a_r$  is coefficient of  $x^{10-r}$  in expansion of  $(1+x)^{10}$  then find  $\sum r^3 \times \left( \frac{a_r}{a_{r-1}} \right)^2$

**Answer: 1210.00**

**Solution:**

$$\sum r^3 \times \left( \frac{a_r}{a_{r-1}} \right)^2 = \sum r^3 \times \left( \frac{{}^{10}C_r}{{}^{10}C_{r-1}} \right)^2$$

$$\sum_{r=1}^{10} r^3 \times \frac{(11-r)^2}{r^2}$$

$$\sum_{r=1}^{10} r(11-r)^2$$

$$\sum_{r=1}^{10} (11-r)(r)^2$$

$$\sum_{r=1}^{10} (11r^2 - r^3)$$

Put  $r = 10$

We will get 1210

**Question:** Given that  $1 \leq x, y \leq 25$ . In how many ways  $x + y$  can be divisible by 5.

**Answer: 125.00**

**Solution:**

Let  $5k, 5k+1, 5k+2, 5k+3, 5k+4$  respect to 5

$$5k_1, 5k_2 \rightarrow 5 \times 5 = 25$$

$$5k+1, 5k+4 \rightarrow 5 \times 5 \times 2 = 50$$

$$5k+2, 5k+3 \rightarrow 5 \times 5 \times 2 = 50$$

**Question:** If sum of all solutions of  $\tan^{-1} \left( \frac{2x}{1-x^2} \right) + \cot^{-1} \left( \frac{1-x^2}{2x} \right) = \frac{\pi}{3}$ ,  $x \in [-1, 1]$  is  $\alpha - \frac{4}{\sqrt{3}}$

then  $\alpha$  is equal to

**Answer: 2.00**

**Solution:**

For  $x < 0$

$$2 \tan^{-1} x + \pi + 2 \tan^{-1}(x) = \frac{\pi}{3}$$

$$2 + \tan^{-1} x = -\frac{2\pi}{3}$$

$$\tan^{-1} x = -\frac{\pi}{3}$$

$$x = \frac{-1}{\sqrt{3}}$$

For  $x > 0$

$$2 \tan^{-1} x + 2 \tan^{-1} x = \frac{\pi}{3}$$

$$4 \tan^{-1} x = \frac{\pi}{3}$$

$$\tan^{-1} x = \frac{\pi}{12} = 2 - \sqrt{3}$$

$$\text{Sum} = 2 - \sqrt{3} - \frac{1}{\sqrt{3}}$$

$$= \frac{2\sqrt{3} - 3 - 1}{\sqrt{3}}$$

$$= 2 - \frac{4}{\sqrt{3}}$$

By comparing with  $\alpha - \frac{4}{\sqrt{3}}$  we get  $\alpha = 2$

**Question:** If  $y = (1+x)(1+x^2)(1+x^4)(1+x^8)(1+x^{16})$  then  $y'(-1) - y''(-1) = ?$

**Answer: 496.00**

**Solution:**

$$y = \frac{1}{(1-x)}(1-x^{32})$$

$$(1-x)y = (1-x^{32})$$

$$-y + (1-x)y' = -32x^{31}$$

$$\text{For } x = -1; 0 + 2y' = 32$$

$$y'(-1) = 16$$

Again differentiating  $-y + (1-x)y' = -32x^{31}$

$$-y' = y' + (1-x)y'' = -32 \cdot 31x^{30}$$

For  $x = -1$ ;  $-2(16) + 2y'' = -32 \cdot 31$

$$y''(-1) = -480$$

$$y'(-1) - y''(-1) = 16 - (-480) = 496$$

**Question:** Evaluate:  $I = \int_0^2 e^{|x-t|} dt$

**Answer:**  $2e - 2$

**Solution:**

$$\text{Let } f(x) = \int_0^2 e^{|x-t|} dt$$

For  $x > 2$

$$f(x) = \int_0^2 e^{x-t} dt \Rightarrow e^x (-e^{-t}) \Big|_0^2 \Rightarrow e^x (1 - e^{-2})$$

For  $x < 0$

$$f(x) = \int_0^2 e^{t-x} dt \Rightarrow e^{-x} e^t \Big|_0^2 \Rightarrow e^{-x} (e^2 - 1)$$

For  $0 \leq x \leq 2$

$$f(x) = \int_0^x e^{x-t} dt + \int_x^2 e^{t-x} dt$$

$$= -e^x e^{-t} \Big|_0^x + e^{-x} e^t \Big|_x^2$$

$$= -e^x (e^{-x} - 1) + e^{-x} (e^2 - e^x)$$

$$= -1 + e^x + e^{2-x} - 1$$

$$= e^{2-x} + e^x - 2$$

$$f(x) = \begin{cases} e^x (1 - e^{-2}) & ; \quad x > 2 \\ e^{2-x} + e^x - 2 & ; \quad 0 \leq x \leq 2 \\ e^{-x} (e^2 - 1) & ; \quad x < 0 \end{cases}$$

For  $x > 2$

$$f(x)_{\min} = e^2 - 1$$

For  $0 \leq x \leq 2$

$$f'(x) = -e^{2-x} + e^x = 0$$

$$\Rightarrow e^x = e^{2-x}$$

$$\Rightarrow e^{2x} = e^2$$

$$\Rightarrow x = 1$$

$$f(x) = 2e - 2 = 2(e - 1)$$

**Question:** The mean and variance of a data was found to be 10 and 4 respectively. Observation 8 was removed and observation 12 was added. Now, new mean is 10.2. What will be the new variance?

**Answer: 3.96**

**Solution:**

Let number of observations be  $n$

$$(10.2)n = 10n - 8 + 12$$

$$(10.2)n = 10n + 4$$

$$\Rightarrow n = 20$$

For earlier set of observations

$$\frac{\sum x_i^2}{20} - (10)^2 = 4$$

$$\Rightarrow \sum x_i^2 = (104)(20) = 2080$$

After change

$$\begin{aligned} \left(\sum x_i^2\right)_{\text{new}} &= 2080 - 8^2 + 12^2 \\ &= 2160 \end{aligned}$$

$$\begin{aligned} \text{New variance} &= \frac{2160}{20} - (10.2)^2 \\ &= 108 - (10.2)^2 \\ &= 3.96 \end{aligned}$$

**Question:** If  $|z - z_1|^2 + |z - z_2|^2 = |z_1 - z_2|^2$ , where  $z_1 = 2 + 3i$  and  $z_2 = 3 + 4i$ , then locus of  $z$  is

**Answer:** Circle with radius  $\frac{1}{\sqrt{2}}$

**Solution:**

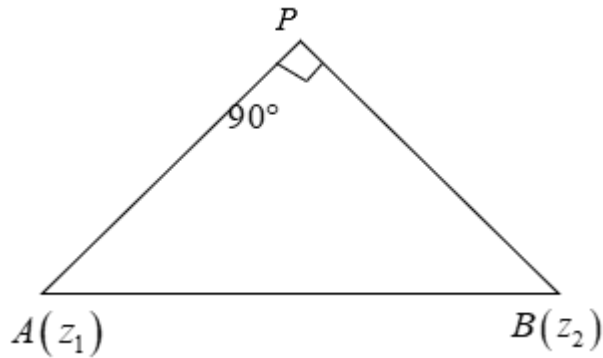

So locus of P is circle whose diameter is AB

$$AB = \sqrt{2}$$

$$\therefore \text{radius of circle} = \frac{1}{\sqrt{2}}$$

**Question:** If  $f(x) = x^3 + 3$ ,  $g(x) = ax + c$  and  $(g(f(x)))^{-1} = \left(\frac{x-7}{2}\right)^{\frac{1}{3}}$  then

$$f \circ g(a) + g \circ f(b) = ?$$

**Answer: 189.00**

**Solution:**

$$g(f(x)) = a(x^3 + 3) + c$$

$$(g(f(x)))^{-1} = \left(\frac{x-3a-c}{a}\right)^{\frac{1}{b}} = \left(\frac{x-7}{2}\right)^{\frac{1}{3}}$$

$$\Rightarrow a = 2, b = 3, c = 1$$

$$g(x) = 2x + 1, f(x) = x^3 + 3$$

$$\text{Now } f \circ g(2) + g \circ f(3) = 128 + 61 = 189$$