

PART : PHYSICS

1. In the given circuit, find the equivalent resistance between A and B.

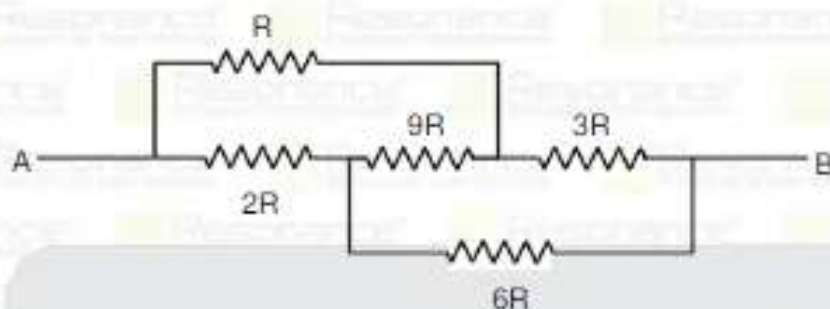

(1) $\frac{2}{3} R$

(2) $\frac{8}{3} R$

(3) $\frac{R}{3}$

(4) $\frac{R}{4}$

Ans. (2)

Sol. Given circuit is balanced wheat stone bridge.

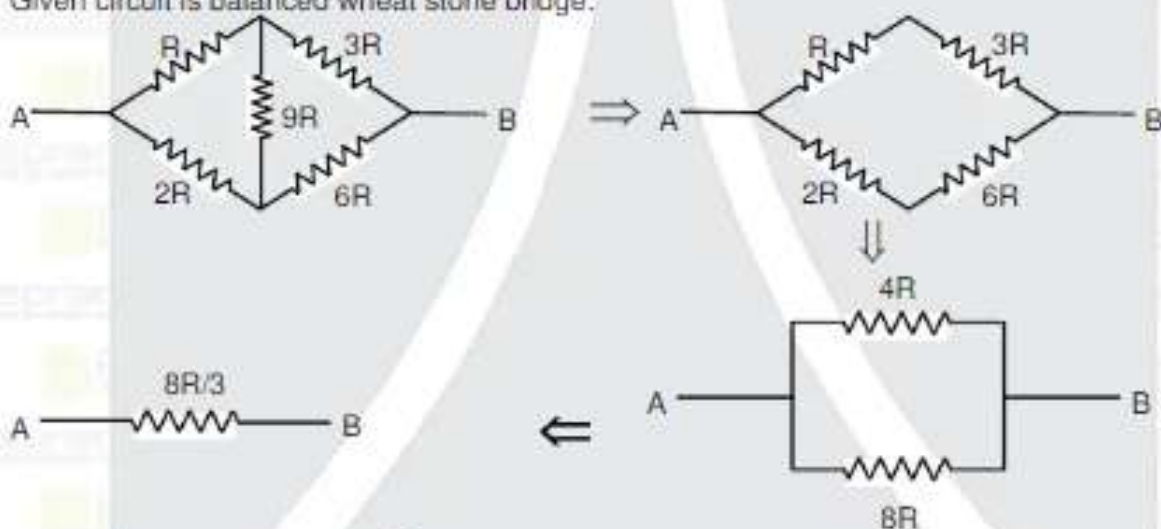

$$R_{eq} = \frac{R_1 R_2}{R_1 + R_2} = \frac{8R \times 4R}{12R} = \frac{8R}{3}$$

2. A projectile is thrown horizontally from a 10 m tower with initial velocity of 5 m/s. Find velocity of projectile just before hitting the ground.

(1) 10 m/s

(2) 18 m/s

(3) 15 m/s

(4) 25 m/s

Ans. (3)

Sol.

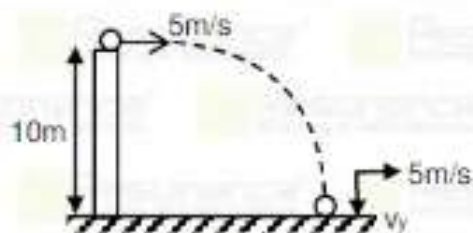

$$v_y = \sqrt{2gh} = \sqrt{2 \times 10 \times 10} = 10\sqrt{2} \text{ m/s} \Rightarrow v = \sqrt{v_x^2 + v_y^2} = \sqrt{200 + 25} = 15 \text{ m/s}$$

Resonance Eduventures Ltd.

Reg. Office & Corp. Office : CG Tower, A-46 & 52, IPIA, Near City Mall, Jhalawar Road, Kota (Raj.) - 324005

Ph. No. : +91-744-2777777, 2777700 | FAX No. : +91-022-39167222

To Know more : sms RESO at 56677 | Website : www.resonance.ac.in | E-mail : contact@resonance.ac.in | CIN : U80302RJ2007PLC024029

Toll Free : 1800 258 5555 | 7340010333 | [facebook.com/ResonanceEdu](https://www.facebook.com/ResonanceEdu) | twitter.com/ResonanceEdu | www.youtube.com/resonance | www.resonance.ac.in

3. If a solid cylinder rolls along an inclined plane of inclination 30° and length of inclined plane is 60 m. then find the velocity of cylinder when it reaches to bottom.

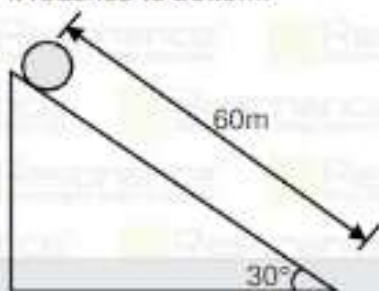

- (1) 40 m/s (2) 20 m/s (3) $20\sqrt{3}$ m/s (4) 45 m/s

Ans. (2)

Sol. $a = \frac{g \sin \theta}{1 + \frac{k^2}{r^2}} = \frac{g \sin \theta}{1 + \frac{1}{2}} = \frac{2}{3} g \sin \theta = \frac{2}{3} \times 10 \times \sin 30^\circ = \frac{10}{3} \text{ m/s}^2$

$$v^2 = u^2 + 2as$$

$$v^2 = 0 + 2 \times \frac{10}{3} \times 60$$

$$\text{then } v^2 = 400$$

$$v = 20 \text{ m/s}$$

4. Find magnetic field strength at point O.

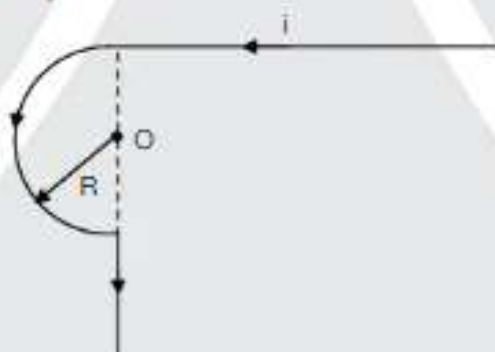

- (1) $\frac{\mu_0 i}{4R} \left(\frac{\pi-1}{\pi} \right)$ (2) $\frac{\mu_0 i}{4R} \left(\frac{\pi+1}{\pi} \right)$ (3) $\frac{\mu_0 i}{R} \left(\frac{\pi+1}{\pi} \right)$ (4) $\frac{\mu_0 i}{2R} \left(\frac{\pi+1}{\pi} \right)$

Ans. (2)

Sol. $B_0 = B_1 + B_2 + B_3$
 $= \frac{\mu_0 i}{4\pi R} + \frac{\mu_0 i}{4R} + 0$
 $= \frac{\mu_0 i}{4R} \left(\frac{\pi+1}{\pi} \right)$

Resonance Eduventures Ltd.

Reg. Office & Corp. Office : CG Tower, A-46 & 52, IPIA, Near City Mall, Jhalawar Road, Kota (Raj.) - 324005

Ph. No.: +91-744-2777777, 2777700 | FAX No.: +91-022-39167222

To Know more : sms RESO at 56677 | Website : www.resonance.ac.in | E-mail : contact@resonance.ac.in | CIN : U80302RU2007PLC024029

Toll Free : 1800 258 5555 | 7340010333 | [facebook.com/ResonanceEd](https://www.facebook.com/ResonanceEd) | [twitter.com/ResonanceEd](https://www.twitter.com/ResonanceEd) | www.youtube.com/resoedtech | [blog.resonance.ac.in](https://www.blog.resonance.ac.in)

5. De-Broglie wavelength of α -particle is the same as that of a proton moving with $\frac{1}{10}$ of velocity as the speed of light. The ratio of K.E. of proton to that of α -particle is.
 (1) 2 : 1 (2) 1 : 4 (3) 4 : 3 (4) 4 : 1

Ans. (4)

Sol. $\lambda = \frac{h}{p} = \frac{h}{mv}$

$\lambda_{\alpha} = \lambda_p$

$\frac{h}{m_{\alpha} v_{\alpha}} = \frac{h}{m_p v_p}$ [$m_{\alpha} = 4m_p$]

$4m_p v_{\alpha} = m_p \frac{C}{10}$

$v_{\alpha} = \frac{C}{40}$

$\frac{(KE)_p}{(KE)_{\alpha}} = \frac{\frac{1}{2} m_p \left(\frac{C}{10}\right)^2}{\frac{1}{2} 4m_p \left(\frac{C}{40}\right)^2} = \frac{1600}{4 \times 100} = \frac{4}{1} = 4 : 1$

6. A body is travelling with velocity v_1 to cover AB, with velocity v_2 to cover BC and with velocity v_3 to cover distance CD. Find the average velocity (given $AB = BC$ and $AD = 3AB$)

(1) $\frac{3v_1 v_2 v_3}{v_1 v_2 + v_2 v_3 + v_1 v_3}$ (2) $\frac{3v_1 v_2 v_3}{v_1 v_2 - v_2 v_3 - v_1 v_3}$ (3) $\frac{v_1 v_2 + v_2 v_3 + v_1 v_3}{3v_1 v_2 v_3}$ (4) $\frac{v_1 v_2 + v_2 v_3 - v_1 v_3}{3v_1 v_2 v_3}$

Ans. (1)
 Sol.

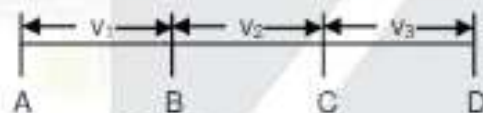

Let say $AB = d$ meter

then $BC = d$ meter

$AD = AB + BC + CD = 3AB$

$\therefore AB = BC \Rightarrow 2AB + CD = 3AB$

$\Rightarrow CD = AB$

Hence $CD = d$ meter

Average velocity = $\frac{3d}{\frac{d}{v_1} + \frac{d}{v_2} + \frac{d}{v_3}} = \frac{d}{d} \left(\frac{3}{\frac{1}{v_1} + \frac{1}{v_2} + \frac{1}{v_3}} \right)$

Average velocity = $\frac{3}{\frac{v_2 v_3 + v_1 v_3 + v_1 v_2}{v_1 v_2 v_3}} = \frac{3v_1 v_2 v_3}{v_1 v_2 + v_2 v_3 + v_1 v_3}$

Resonance Eduventures Ltd.

Reg. Office & Corp. Office : CG Tower, A-46 & 52, IPIA, Near City Mall, Jhalawar Road, Kota (Raj.) - 324005

Ph. No.: +91-744-2777777, 2777700 | FAX No.: +91-022-39167222

To Know more : sms RESO at 56677 | Website : www.resonance.ac.in | E-mail : contact@resonance.ac.in | CIN : U80302RJ2007PLC024029

Toll Free : 1800 258 5555 7340010333 facebook.com/ResonanceEdu twitter.com/ResonanceEdu www.youtube.com/reswatch blog.resonance.ac.in

7. Mass of a planet is $1/9$ times mass of earth and radius of planet is $1/2$ times radius of earth. If escape velocity on the surface of planet is $\frac{v_0}{3} \sqrt{x}$, then what will be value of x . (v_0 = Escape velocity on the surface of earth.)
 (1) 3 (2) 2 (3) 1 (4) 4

Ans. (2)

Sol. We know that escape velocity $v = \sqrt{\frac{2GM}{R}}$
 given $M_p = \frac{m_e}{9}$, $R_p = \frac{R_e}{2} \Rightarrow v_p = \sqrt{\frac{2GM_p}{R_p}} = \sqrt{\frac{2 \times G \times m_e / 9}{R_e / 2}}$

$$v_p = \sqrt{\frac{2 \times 2Gm_e}{9R_e}} \dots\dots(1)$$

$$\text{also } v_0 = \sqrt{\frac{2Gm_e}{R_e}} \dots\dots(2)$$

from question (1) and (2)

$$v_p = \frac{v_0}{3} \sqrt{2}$$

so, $x = 2$

8. Two positive charge of q coulomb are placed with a separation of $2a$. Distance of a point on the perpendicular bisector of line joining of these two charge, where a test charge experiences the maximum force, is a/\sqrt{x} find the value of x .
 (1) 2 (2) 3 (3) 4 (4) 5

Ans. (1)

Sol. Let us assume at y F will be maximum

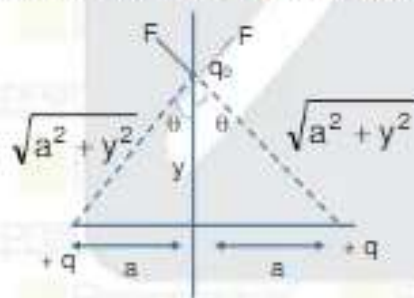

$$F_{\text{net}} = 2 F \cos\theta \Rightarrow F_{\text{net}} = \frac{2kqq_0y}{(a^2 + y^2)^{3/2}}$$

$$\text{For } F_{\text{max}} \frac{dF_{\text{net}}}{dy} = 0$$

$$\text{then } y = \frac{a}{\sqrt{2}} \Rightarrow \frac{a}{\sqrt{2}} = \frac{a}{\sqrt{x}}$$

Then the value of x is 2

Resonance Eduventures Ltd.

Reg. Office & Corp. Office : CG Tower, A-46 & 52, IPIA, Near City Mall, Jhalawar Road, Kota (Raj.) - 324005

Ph. No.: +91-744-2777777, 2777700 | FAX No. : +91-022-39167222

To Know more : sms RESO at 56677 | Website : www.resonance.ac.in | E-mail : contact@resonance.ac.in | CIN : U80302RJ2007PLC024029

Toll Free : 1800 258 5555 7340010333 facebook.com/ResonanceEdu better sms/ResonanceEdu www.youtube.com/resowatch blog.resonance.ac.in

9. In Vander walls equation given below $\left(p + \frac{an^2}{V^2}\right)(V - nb) = nRT$ then dimension of b^2/a is equal to :
- (1) Bulk modulus (2) Modulus of rigidity (3) Compressibility (4) Planck's constant

Ans. (3)

Sol. $\left(p + \frac{an^2}{V^2}\right) \cdot a = \frac{PV^2}{n^2}$

$$a = \frac{M^1 L^{-1} \times L^6}{(\text{mol})^2} = M^1 L^5 T^{-2} \text{ mol}^{-2}$$

$$nb = V$$

$$b = V/n = L^3/\text{mol}$$

$$\text{then } \frac{b^2}{a} = \frac{L^6 \text{ mol}^2}{\text{mol}^2 M^1 L^5 T^{-2}}$$

$$= M^{-1} L^1 T^2 \text{ is the dimension of compressibility.}$$

10. For an adiabatic process initial pressure is P and temperature is T. What will be work done during process volume is twice of initial volume. ($\gamma = 3/2$)

- (1) $nRT(2 + \sqrt{2})$ (2) $nRT(1 - \sqrt{2})$ (3) $nRT(2 - \sqrt{2})$ (4) $nRT(1 + \sqrt{2})$

Ans. (3)

Sol. $W = \frac{P_1 V_1 - P_2 V_2}{\gamma - 1} = \frac{nR(T_1 - T_2)}{\gamma - 1}$

for an adiabatic process $T_1 V_1^{\gamma-1} = T_2 V_2^{\gamma-1}$

$$T \times V^{\frac{3}{2}-1} = T_2 \times (2V)^{\frac{3}{2}-1}$$

$$\frac{T}{\sqrt{2}} = T_2$$

$$W = \frac{nR\left(T - \frac{T}{\sqrt{2}}\right)}{\frac{3}{2} - 1}$$

$$W = \frac{nRT(\sqrt{2} - 1)}{\sqrt{2} \times \frac{1}{2}}$$

$$W = nRT(2 - \sqrt{2})$$

11. A particle is moved from $\vec{r}_1 = 2\hat{i} - \hat{j} + 7\hat{k}$ to $\vec{r}_2 = 5\hat{i} - 3\hat{j} + \hat{k}$ by force $\vec{F} = 5\hat{i} + 3\hat{j} + 2\hat{k}$. Find work done in this process :

- (1) -3 (2) +3 (3) +2 (4) -2

Ans. (1)

Resonance Eduventures Ltd.

Reg. Office & Corp. Office : CG Tower, A-46 & 52, IPIA, Near City Mall, Jhalawar Road, Kota (Raj.) - 324005

Ph. No.: +91-744-2777777, 2777700 | FAX No. : +91-022-39167222

To Know more : sms RESO at 56677 | Website : www.resonance.ac.in | E-mail : contact@resonance.ac.in | CIN : U80302RJ2007PLC024029

Toll Free : 1800 258 5555 7340010333  facebook.com/ResonanceEdu  twitter.com/ResonanceEdu  www.youtube.com/resowatch  instg.resonance.ac.in

Sol. Work done = Force · Displacement

$$W = \vec{F} \cdot \vec{r}$$

$$\text{Here } \vec{r} = \vec{r}_2 - \vec{r}_1$$

$$\vec{r}_2 = 5\hat{i} - 3\hat{j} + \hat{k}$$

$$\vec{r}_1 = 2\hat{i} - \hat{j} + 7\hat{k}$$

$$\vec{r} = (5 - 2)\hat{i} + (-3 - (-1))\hat{j} + (1 - 7)\hat{k}$$

$$\vec{r} = 3\hat{i} - 2\hat{j} - 6\hat{k}$$

$$\begin{aligned} \text{Workdone} &= \vec{F} \cdot \vec{r} = (5\hat{i} + 3\hat{j} + 2\hat{k}) \cdot (3\hat{i} - 2\hat{j} - 6\hat{k}) \\ &= (15 - 6 - 12) \text{ J} \end{aligned}$$

$$\text{Workdone} = -3 \text{ Joule}$$

12. Calculate the binding energy of He atom's nucleus.

Given : $m_p = 1.00727 \text{ amu}$, $m_n = 1.008 \text{ amu}$, $m_{\text{He}} = 4.0026 \text{ amu}$

(1) 4.1 mJ

(2) 6.2 mJ

(3) 8.1 mJ

(4) 12.3 mJ

Ans. (1)

Sol. $\Delta m = \text{mass defect} = (2 m_p + 2 m_n) - m_{\text{He}}$

$$\Delta m = (2 \times 1.007) + 2 (1.008) - 4.0026$$

$$= (2.014 + 2.016) - 4.0026$$

$$= 4.03 - 4.0026$$

$$\Delta m = 0.0274 \times 1.661 \times 10^{-18}$$

$$E = \Delta m \times C^2 = 0.0274 \times 1.661 \times 10^{-18} \times (3 \times 10^8 \times 3 \times 10^8) = 0.4096 \times 10^{-2}$$

$$E = 4.09 \times 10^{-3} \text{ J}$$

$$E = 4.1 \text{ mJ}$$

13. If tension in a string is 70 N and linear mass density of string is $7 \times 10^{-3} \text{ kg/m}$, the velocity of string wave is _____.

(1) 10 m/s

(2) 35 m/s

(3) 60 m/s

(4) 100 m/s

Ans. (4)

$$\text{Sol. } V = \sqrt{\frac{T}{\mu}}$$

$$V = \sqrt{\frac{70}{7 \times 10^{-3}}}$$

$$V = 100 \text{ m/s}$$

14. Which of the following frequency does not lie in FM range.

(1) 88 MHz

(2) 64 MHz

(3) 99 MHz

(4) 106 MHz

Ans. (2)

Sol. Range of FM frequency = (88 – 108) MHz then 64 MHz is not the FM frequency.

Resonance Eduventures Ltd.

Reg. Office & Corp. Office : CG Tower, A-46 & 52, IPIA, Near City Mall, Jhalawar Road, Kota (Raj.) - 324005

Ph. No.: +91-744-2777777, 2777700 | FAX No.: +91-022-39167222

To Know more : sms RESO at 56677 | Website : www.resonance.ac.in | E-mail : contact@resonance.ac.in | CIN : U80302RJ2007PLC024029

Toll Free : 1800 258 5555 | 7340010333 | [facebook.com/ResonanceEdu](https://www.facebook.com/ResonanceEdu) | [twitter.com/ResonanceEdu](https://www.twitter.com/ResonanceEdu) | www.youtube.com/resonance | www.instagram.com/resonance.ac.in

15. Two infinite metallic plates are placed parallel to each other as shown. Find the electric field strength in Region I, region II and Region III.



(1) $E_I = 0, E_{II} = +\frac{\sigma}{2\epsilon_0}, E_{III} = 0$

(2) $E_I = +\frac{\sigma}{\epsilon_0}, E_{II} = 0, E_{III} = \frac{\sigma}{\epsilon_0}$

(3) $E_I = -\frac{\sigma}{2\epsilon_0}, E_{II} = 0, E_{III} = \frac{\sigma}{2\epsilon_0}$

(4) $E_I = 0, E_{II} = 0, E_{III} = 0$

Ans. (2)

Sol.

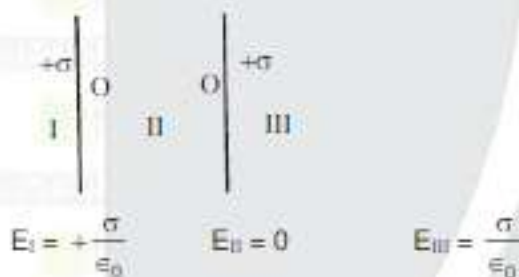

16. Match the following

Fermi level

- | | |
|-----------------------------|---|
| (a) N type | (p) Close to valence band |
| (b) p type | (q) Close to conduction band |
| (c) metal | (r) inside each other |
| (d) Intrinsic semiconductor | (s) In between conduction band and valence band |
- (1) a-q, b-p, c-r, d-s (2) a-s, b-p, c-r, d-p (3) a-p, b-r, c-q, d-s (4) a-r, b-q, c-p, d-s

Ans. (1)

17. Average kinetic energy of gas is

- (1) Directly proportional to pressure (2) Directly proportional to volume
(3) Directly proportional to absolute Temperature (4) All of the above

Ans. (3)

Sol. $\langle \Delta KE \rangle = \frac{1}{2} KT$

$\Delta KE \propto T$

Resonance Eduventures Ltd.

Reg. Office & Corp. Office : CG Tower, A-46 & 52, IPIA, Near City Mall, Jhalawar Road, Kota (Raj.) - 324005

Ph. No.: +91-744-2777777, 2777700 | FAX No. : +91-022-39167222

To Know more : sms RESO at 56677 | Website : www.resonance.ac.in | E-mail : contact@resonance.ac.in | CIN : U80302RJ2007PLC024029

Toll Free : 1800 258 5555 7340010333 facebook.com/ResonanceEdu twitter.com/ResonanceEdu www.youtube.com/resoventures www.resonance.ac.in

18. A force of 30N (Horizontally) is applied on a block of mass 5 kg which is kept on a rough surface having friction co-efficient μ . Block travelled 50m in 10 second then find the μ .

(1) 0.2 (2) 1.2 (3) 1.5 (4) 0.5

Ans. (4)

Sol.

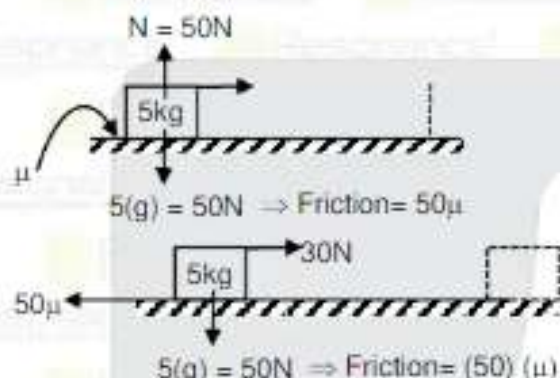

$$F_{\text{net}} = (30 - 50\mu)\text{N}$$

$$a_{\text{net}} = \frac{30 - 50\mu}{5} = (6 - 10\mu)\text{m/s}^2$$

Travelled displacement = 50 m
 time taken = 10 sec

$$\Rightarrow S = ut + \frac{1}{2}at^2$$

$$50 = 0(t) + \frac{1}{2}(6 - 10\mu)(10)^2$$

$$50 = \frac{1}{2}(6 - 10\mu)100$$

$$\Rightarrow \frac{50 \times 2}{100} = (6 - 10\mu) \Rightarrow 6 - 10\mu = 1$$

$$10\mu = 6 - 1 = 5$$

$$\mu = 5/10 = 0.5$$

$$\mu = 0.5$$

19. In LCR circuit L, C, R is connected with source of 220V, 50 Hz. Resistance and inductive reactance are 100Ω and 79.6Ω . Find the value of capacitive reactance when current flow in circuit is maximum :

(1) 69.6Ω (2) 79.6Ω (3) 89.6Ω (4) 65.9Ω

Ans. (2)

Sol. given $X_L = 79.6\Omega$

$$R = 100\Omega$$

$$V_{\text{rms}} = 220\text{V}$$

I_{max} in the circuit at resonance condition

$$Z = R$$

$$\text{then } X_L = X_C$$

$$X_C = 79.6\Omega$$

Resonance Eduventures Ltd.

Reg. Office & Corp. Office : CG Tower, A-46 & 52, IPIA, Near City Mall, Jhalawar Road, Kota (Raj.) - 324005

Ph. No.: +91-744-2777777, 2777700 | FAX No.: +91-022-39167222

To Know more : sms RESO at 56677 | Website : www.resonance.ac.in | E-mail : contact@resonance.ac.in | CIN : U80302RJ2007PLC024029

Toll Free : 1800 258 5555 7340010333 facebook.com/ResonanceEdu twitter.com/ResonanceEdu www.youtube.com/reswitch blog.resonance.ac.in

20. **Statement-I** : value of gravity is different at different latitudes on the surface of earth.

Statement-II : value of gravity increases as we go deep from the surface of earth.

- (1) Statement-1 is True, Statement-2 is True; Statement-2 is a correct explanation for Statement-1.
 (2) Statement-1 is True, Statement-2 is True; Statement-2 is NOT a correct explanation for Statement-1
 (3) Statement-1 is True, Statement-2 is False
 (4) Statement-1 is False, Statement-2 is True

Ans. (3)

Sol. gravity on surface of earth $g' = (g - R\omega^2 \cos^2\theta)$, so as latitude changes, value of gravity also changes at each point on surface of earth.

As we go deep $g' = g \left(1 - \frac{d}{R}\right) \Rightarrow$ gravity decreases so, statement 1 is correct and statement 2 is wrong

21. In a hydrogen atom, an electron in ground state receive 12.75 eV. Calculate the angular momentum of electron in the higher energy level

- (1) $\frac{12.48}{\pi} \times 10^{-34}$ (2) $\frac{14.67}{\pi} \times 10^{-34}$ (3) $\frac{13.24}{\pi} \times 10^{-34}$ (4) $\frac{10.28}{\pi} \times 10^{-34}$

Ans. (3)

Sol. $12.75 = -13.6 \left(\frac{1}{x^2} - \frac{1}{12}\right)$

$$12.75 = -\frac{13.6}{x^2} + 13.6$$

$$x^2 = \frac{+13.6}{+0.85} = 16$$

$$x = 4$$

$$mvr = \frac{xh}{2\pi} \Rightarrow L = 4 \times \frac{h}{2\pi}$$

$$L = \frac{2h}{\pi} = \frac{2 \times 6.62 \times 10^{-34}}{\pi} = \frac{13.24 \times 10^{-34}}{\pi}$$

22. A drop of liquid is divided into 125 drops of radius 10^{-3} m each. Its surface tension of liquid is 0.45 N/m then change in magnitude of surface energy is —

- (1) 5.65×10^{-4} Joule (2) 7.65×10^{-4} Joule (3) 12.66×10^{-4} Joule (4) 3.65×10^{-4} Joule

Ans. (1)

Sol. $V_i = V_f$

$$\frac{4}{3} \pi R^3 = 125 \times \frac{4}{3} \pi r^3$$

$$R = 5r$$

$$\Delta U = S \Delta A$$

$$= 0.45 [125 \times 4\pi r^2 - 4\pi R^2] = 0.45 [125 \times 4\pi r^2 - 4\pi(5r)^2]$$

$$= 0.45 \times 400 \pi r^2 = 180 \pi \times 10^{-6} = 5.65 \times 10^{-4}$$

Resonance Eduventures Ltd.

Reg. Office & Corp. Office : CG Tower, A-46 & 52, IPIA, Near City Mall, Jhalawar Road, Kota (Raj.) - 324005

Ph. No. : +91-744-2777777, 2777700 | FAX No. : +91-022-39167222

To Know more : sms RESO at 56677 | Website : www.resonance.ac.in | E-mail : contact@resonance.ac.in | CIN : U80302RJ2007PLC024029

Toll Free : 1800 258 5555 7340010333  [facebook.com/ResonanceEd](https://www.facebook.com/ResonanceEd)  twitter.com/ResonanceEd  www.youtube.com/resonance  blog.resonance.ac.in

23. Two radioactive substances A and B have half life of 5 min and 15 min respectively. The initial amount of A is 4 times of B. calculate the time when the remaining amount of both substances will be same.
 (1) 10 min (2) 25 min (3) 15 min (4) 50 min

Ans. (3)

Sol. $m_A = m_B$

$$m_A \xrightarrow{5\text{min}} \frac{m_A}{2} \xrightarrow{5\text{min}} \frac{m_A}{4} \xrightarrow{5\text{min}} \frac{m_A}{8} = \frac{m_B}{2} \xrightarrow{15\text{min}} \frac{m_B}{2}$$

$$\left[\frac{m_A}{8} = \frac{m_B}{2} \right]$$

So after 15 min amount of both will be same.

24. A charged particle with charge $2 \times 10^{-6}\text{C}$ at rest is first accelerated through a potential difference of 100V and then it is subjected to a transverse magnetic field of 4mT. In a region of magnetic field it undergoes a circular path of radius 3 cm. Mass of the particle is equal to :
 (1) $1.44 \times 10^{-14}\text{ kg}$ (2) $1.44 \times 10^{-16}\text{ kg}$ (3) $2.44 \times 10^{-10}\text{ kg}$ (4) $1.44 \times 10^{-6}\text{ kg}$

Ans. (2)

Sol. $w = \Delta\text{K.E.}$

$$9\text{V} = 1/2 mV^2$$

$$2 \times 10^{-6} \times 100 = 1/2 \times m \times V^2$$

$$\therefore V = \sqrt{\frac{4 \times 10^{-4}}{m}}$$

Radius of moving charge in transverse magnetic field

$$R = \frac{mV}{qB}$$

$$3 \times 10^{-2} = m \times \sqrt{\frac{4 \times 10^{-4}}{m}}$$

$$2 \times 10^{-6} \times 4 \times 10^{-3}$$

$$\sqrt{m} = \frac{24 \times 10^{-11}}{2 \times 10^{-2}} = 12 \cdot 10^{-9}$$

$$m = 144 \times 10^{-18}\text{ kg} = 1.44 \times 10^{-16}\text{ kg}$$

Resonance Eduventures Ltd.

Reg. Office & Corp. Office : CG Tower, A-46 & 52, IPIA, Near City Mall, Jhalawar Road, Kota (Raj.) - 324005

Ph. No.: +91-744-2777777, 2777700 | FAX No. : +91-022-39167222

To Know more : sms RESO at 56677 | Website : www.resonance.ac.in | E-mail : contact@resonance.ac.in | CIN : U80302RJ2007PLC024029

Toll Free : 1800 258 5555 7340010333 facebook.com/ResonanceEdU twitter.com/ResonanceEdU www.youtube.com/resonancewatch blog.resonance.ac.in

25. There are n number of polarizers arranged one after the other. Axis of each polarizer is inclined at 45° with respect to the previous polarizer. Unpolarized light of intensity I_0 is incident on this setup. Final transmitted light has intensity $\frac{I_0}{64}$. Find n .

- (1) 4 (2) 8 (3) 10 (4) 6

Ans. (4)

Sol. $I = I_0 \cos^2 \phi = I_0 \cos^2 45^\circ = \frac{I_0}{2}$

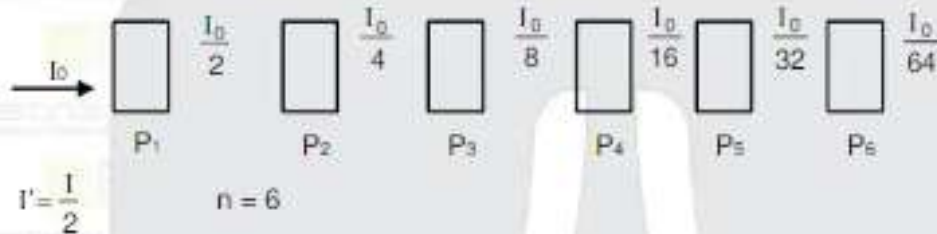

26. A rod of 10 cm is kept along the axis of a concave mirror whose focal length is 20 cm. If centre rod lies 40 cm away from the mirror then if length of image of rod is $x/3$ cm, calculate x .

- (1) 43 (2) 32 (3) 17 (4) 19

Ans. (2)

Sol.

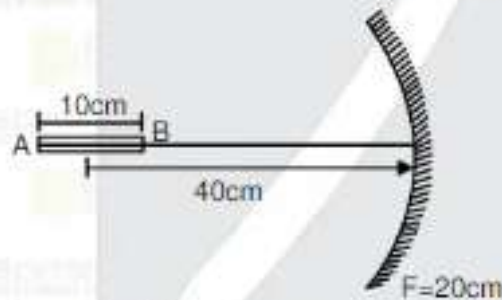

$$\frac{1}{v_B} + \frac{1}{u_B} = \frac{1}{f}$$

$$\frac{1}{v} + \frac{1}{-35} = \frac{1}{-20}$$

$$\frac{1}{v} = \frac{1}{-20} + \frac{1}{35} = \frac{35 - 20}{35 \times -20} = \frac{15}{-35 \times 20} = \frac{-140}{3} = v$$

$$\frac{1}{v_A} + \frac{1}{u_A} = \frac{1}{f} \quad ; \quad \frac{1}{v_A} - \frac{1}{45} = \frac{1}{-20}$$

$$\frac{1}{v_A} = -\frac{1}{20} + \frac{1}{45} = \frac{45 - 20}{45 \times -20} = \frac{25}{45 \times -20} = -36$$

$$l = v_A - v_B = -36 + \frac{140}{3} = \frac{-108 + 140}{3}$$

$$l = \frac{32}{3} \Rightarrow x = 32$$

Resonance Eduventures Ltd.

Reg. Office & Corp. Office : CG Tower, A-46 & 52, IPIA, Near City Mall, Jhalawar Road, Kota (Raj.) - 324005

Ph. No.: +91-744-2777777, 2777700 | FAX No.: +91-022-39167222

To Know more : sms RESO at 56677 | Website : www.resonance.ac.in | E-mail : contact@resonance.ac.in | CIN : U80302RJ2007PLC024029

Toll Free : 1800 258 5555 | 7340010333 | [facebook.com/ResonanceEd](https://www.facebook.com/ResonanceEd) | twitter.com/ResonanceEd | www.youtube.com/resonance | www.instagram.com/resonance

27. If amplitude of oscillation in a spring mass system is 3 cm and kinetic energy is 125% of potential energy. Calculate the position of the particle from the mean position.

- (1) 6 cm (2) 12 cm (3) 2 cm (4) 10 cm

Ans. (3)

Sol. $TE = \frac{1}{2}KA^2 = \frac{1}{2}K\left(\frac{3}{100}\right)^2$

$TE = KE + PE$

Given $KE = \frac{125}{100} PE = \frac{5}{4} PE$

$\therefore \frac{1}{2}K\left(\frac{3}{100}\right)^2 = \frac{9}{4}PE \quad \left[PE = \frac{1}{2}Kx^2\right]$

$\Rightarrow \frac{1}{2}K\left(\frac{3}{100}\right)^2 = \frac{9}{4} \times \frac{1}{2}Kx^2 \Rightarrow x = \frac{1}{50}m = 2 \text{ cm.}$

28. Match the column :-

- | | |
|-----------------|---|
| (A) r Rays | (P) Radioactive decay |
| (B) X Rays | (Q) Klystron |
| (C) Radio waves | (R) Rapid acceleration & deceleration of electron in aerials (conductors) |
| (D) Microwaves | (S) Inner shell of electrons. |

(1) (A) → (P), (B) → (S), (C) → (R), (D) → (Q)

(2) (A) → (Q), (B) → (S), (C) → (R), (D) → (P)

(3) (A) → (P), (B) → (R), (C) → (S), (D) → Q

(4) (A) → (S), (B) → (P), (C) → (R), (D) → Q

Ans. (1)

Sol. (A) → (P), (B) → (S), (C) → (R), (D) → Q

29. Match the column :-

- | | |
|-----------------------------|------------------------|
| (a) AC | (p) quality factor |
| (b) Transformer | (q) mutual inductances |
| (c) Resonance to occur | (r) EMI |
| (d) Sharpness in Resonances | (s) $X_L = X_C$ |

(1) (a) → (p), (b) → (q), (c) → (s), (d) → (r) (2) (a) → (r), (b) → (q), (c) → (s), (d) → (p)

(3) (a) → (r), (b) → (s), (c) → (q), (d) → (p) (4) (a) → (r), (b) → (q), (c) → (p), (d) → (s)



Ans. (2)

Resonance Eduventures Ltd.

Reg. Office & Corp. Office : CG Tower, A-46 & 52, IPHA, Near City Mall, Jhalawar Road, Kota (Raj.) - 324005

Ph. No.: +91-744-2777777, 2777700 | FAX No. : +91-022-39167222

To Know more : sms RESO at 56677 | Website : www.resonance.ac.in | E-mail : contact@resonance.ac.in | CIN : U80302RJ2007PLC024029

Toll Free : 1800 258 5555 7340010333  facebook.com/ResonanceEdu  twitter.com/ResonanceEdu  www.youtube.com/resowatch  www.resonance.ac.in

30. Pressure is applied on 1L water and 2L of liquid separately. Water compresses by 0.01% and liquid by 0.03%. Ratio of $\beta_{\text{water}}/\beta_{\text{liquid}} = 3/x$. Find x.

(1) 4

(2) 3

(3) 2

(4) 1

Ans. (4)

Sol.
$$\beta = \frac{-P}{\frac{\Delta V}{V}}$$

$$\Rightarrow P = \beta \frac{\Delta V}{V}$$

$$\Rightarrow \frac{\beta_1}{\beta_2} = \frac{\beta_{\text{water}}}{\beta_{\text{liquid}}} = \frac{3}{1}$$

$$\therefore x = 1$$

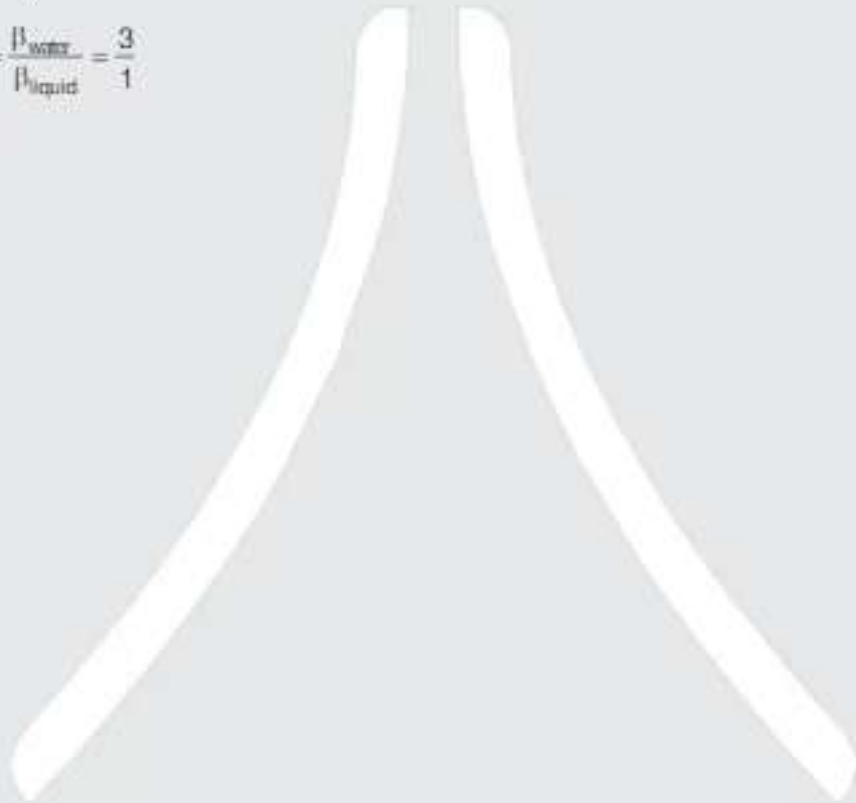





Resonance Eduventures Ltd.

Reg. Office & Corp. Office : CG Tower, A-46 & 52, IPIA, Near City Mall, Jhalawar Road, Kota (Raj.) - 324005

Ph. No.: +91-744-2777777, 2777700 | FAX No.: +91-022-39167222

To Know more : sms RESO at 56677 | Website : www.resonance.ac.in | E-mail : contact@resonance.ac.in | CIN : U80302RJ2007PLC024029

Toll Free : 1800 258 5555  7340010333  facebook.com/ResonanceEdu  twitter.com/ResonanceEdu  www.youtube.com/resonance  @resonance.ac.in