



GATE 2023

**CIVIL
ENGINEERING**

**Memory based
Questions
& Solutions**



Corporate Office: 44-A/1, Kalu Sarai, New Delhi-110016
MADE EASY Centres : Delhi , Hyderabad , Jaipur, Bhopal,
Lucknow, Bhubaneswar, Pune, Kolkata



9021300500



www.madeeasy.in

**Exam held
on 12th Feb, 2023
Forenoon
Session**

SECTION - A

GENERAL APTITUDE

Q.1 The probabilities of occurrences of two independent events A and B are 0.5 and 0.8, respectively. What is the probability of occurrence of atleast A or B.

Ans. (0.9)

As it is independent events so

$$P(A) \cap P(B) = P(A) \times P(B)$$

Given, $P(A) = 0.5$ and $P(B) = 0.8$

So, $P(\bar{A}) = 0.5$ and $P(\bar{B}) = 0.2$

$$\begin{aligned} P(A \cup B) &= P(A) + P(B) - P(A \cap B) \\ &= 0.5 + 0.8 - 0.5 \times 0.8 = 0.9 \end{aligned}$$

End of Solution

Q.2 Find area of shaded region

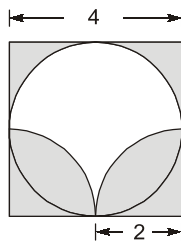

Ans. (8)

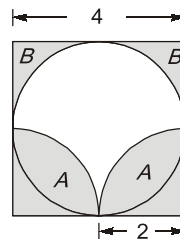

$$\text{Area of quadrant, } A = \frac{1}{4} \pi (2)^2 = \pi$$

$$\begin{aligned} \text{Area of sector, } B &= \text{Area of square} - \text{Area of quadrant} \\ &= 4 - \pi \end{aligned}$$

$$\begin{aligned} \text{So, total shaded area} &= 2A + 2B = 2 \times \pi + 2 \times (4 - \pi) \\ &= 2\pi + 8 - 2\pi = 8 \text{ unit}^2 \end{aligned}$$

End of Solution



NST-2 NATIONAL SCHOLARSHIP TEST 2024

For **ESE, GATE & PSUs 2024**
Offline & Online Long-Term Courses

Register at : www.madeeasy.in

Last Date to Register (Online) : **21st Feb, 2023**

Test Date (Online) : **27th Feb, 2023**

Time Duration 45 Minutes	Total Questions 50 Questions	Total Marks 100 Marks	Negative Marking 0.66 Marks	Streams CE, ME, EE, EC, CS, CH
-----------------------------	---------------------------------	--------------------------	--------------------------------	-----------------------------------

9021300500

nst@madeeasy.in

nst.madeeasy.in

Scan to
Register 

Scholarship applicable on batches commencing between
1st March, 2023 to 31st May, 2023

Delhi Centre : 44 - A/1, Kalu Sarai, Near Hauz Khas Metro Station, New Delhi - 110016 | **Ph** : 9021300500

MADE EASY Centres : Delhi | Hyderabad | Jaipur | Bhopal | Lucknow | Bhubaneswar | Pune | Kolkata | www.madeeasy.in

- Q.3** $a = 30!, b = 50!, c = 100!$ then arrange $\log_a^c, \log_c^a, \log_a^b, \log_b^a$
- (a) $\log_c^a < \log_b^a < \log_a^c < \log_a^b$ (b) $\log_c^a < \log_b^a < \log_a^b < \log_a^c$
 (c) $\log_b^a < \log_c^a < \log_a^b < \log_a^c$ (d) $\log_c^a < \log_a^b < \log_a^c < \log_b^a$

Ans. (b)
Given, $a = 30!, b = 50!$ and $c = 100!$

We know that $\log_n^m = \frac{\log m}{\log n}$

$\log_a^c, \log_c^a, \log_a^b, \log_b^a$

$\frac{\log 100!}{\log 30!}, \frac{\log 30!}{\log 100!}, \frac{\log 50!}{\log 30!}, \frac{\log 30!}{\log 50!}$

$\frac{\log 30!}{\log 100!} < \frac{\log 30!}{\log 50!} < \frac{\log 50!}{\log 30!} < \frac{\log 100!}{\log 30!}$

$\log_c^a < \log_b^a < \log_a^b < \log_a^c$

End of Solution

- Q.4** PQRSTU is a regular hexagon with each side of length 5 cm. A circle is drawn with its centre at V such that it passes through P. What is the area (in cm^2) of the shaded region?

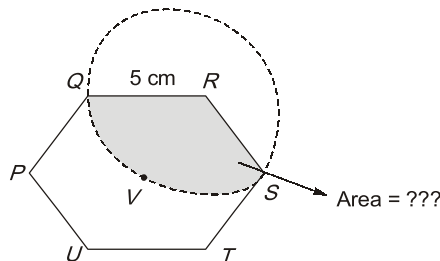

- (a) $\frac{25\pi}{3}$ (b) $\frac{20\pi}{3}$
 (c) 6π (d) 7π

Ans. (a)

Interior angle sum = $(n - 2) \times 180^\circ$
Each angle of regular Hexagon.

$\frac{(n-2) \times 180^\circ}{n} = 120^\circ$

Required area = $\frac{\theta}{360^\circ} \times \pi \times 25 = \frac{25\pi}{3}$

End of Solution

- Q.5** Based on statement, "Some Humans are intelligent". What logical conclusion can be drawn with certainty?
- (a) No Human is intelligent
(b) Some intelligent beings are human
(c) All human are intelligent
(d) Some non-humans are intelligent

Ans. (b)

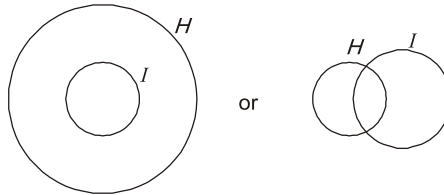

Only option (b) is correct.

End of Solution

- Q.6** I have not yet decided what will i do this evening. I _____ visit a friend.
- (a) might
(b) did not
(c) mite
(d) would

Ans. (a)

End of Solution

- Q.7** Eject : Insert :: Advance : _____.
- (a) Loan
(b) Retreat
(c) Progress
(d) Advent

Ans. (b)

End of Solution

- Q.8** The James Webb telescope, recently launched in space is giving human kind unprecedented access to the depths of time by giving imaging of very old stars formed almost 13 billion years ago. Astrophysicists and cosmetologists believe that this odyssey in space may even shed light on the existence of dark matter. Dark matter is supposed to interact only via the gravitational interaction and not through the electromagnetic weak or the strong interaction. This may justify the epithet 'dark' in dark matter.
- Based on the above paragraph, which one is false?
- (a) No other telescope has captured image of stars older than those captured by the James Webb telescope.
(b) If dark matter known to interact via the strong interaction, then the epithet 'dark' would be justified.
(c) The James Webb telescope could be of use in research on dark matter.
(d) People other than astrophysicists and cosmetologists may also believe in the existence of dark matter.

Ans. (b)



SECTION - B

TECHNICAL

Highway

Q.9 For a horizontal curve, the radius of a circular curve is obtained as 300 m with the design speed as 15 m/s. If the allowable Jerk is 0.75 m/s³, what is the minimum length in m of the transition curve? (round off to nearest integer)

Ans. (15)

Given: $V = 15 \text{ m/s}$
 $R = 300 \text{ m}$
Jerk, $C = 0.75 \text{ m}^3/\text{s}$

So, height of transition curve,

$$L_t = \frac{V^3}{RC} = \frac{15^3}{300 \times 0.75} = 15 \text{ m}$$

Note: We should also find out the length by formula given by IRC but terrain is not mentioned.

End of Solution

Q.10 Given capacity of road A is C_A capacity of road B is C_B , then, $\frac{C_A}{C_B} = ?$

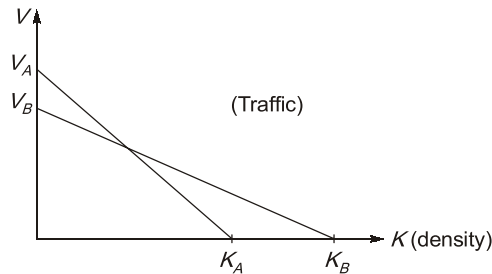

Ans.

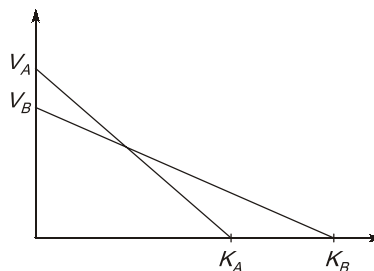

Now, capacity of road A,

$$q_{\max A} = \frac{1}{4} K_A V_A$$



Announcing

FOUNDATION COURSES for **ESE 2024 • GATE 2024**

The Foundation Batches are taught comprehensively which cover the requirements of all technical-syllabus based examinations.

- ✓ Classes by experienced & renowned faculties.
- ✓ Exam oriented learning ecosystem.
- ✓ Systematic subject sequence & timely completion of syllabus.
- ✓ Result oriented teaching with comprehensive coverage.
- ✓ Comprehensive & updated study material.
- ✓ Concept of problems solving through workbooks.
- ✓ Regular performance assessment through class tests.
- ✓ Similar teaching pedagogy in online and offline classes.

OFFLINE BATCHES AT DELHI

Commencing from

- 14th Mar, 2023 • 11th April, 2023
- 4th May, 2023 • 25th May, 2023

LIVE-ONLINE BATCHES

Commencing from

- 15th Feb, 2023 • 14th Mar, 2023
- 15th Apr, 2023 • 15th May, 2023

Admissions open

Delhi Centre : 44 - A/1, Kalu Sarai, Near Hauz Khas Metro Station, New Delhi - 110016 | **Ph :** 9021300500

MADE EASY Centres : Delhi | Hyderabad | Jaipur | Bhopal | Lucknow | Bhubaneswar | Pune | Kolkata | www.madeeasy.in

Similarly, capacity of road B,

$$q_{\max B} = \frac{1}{4} K_B V_B$$

Now,

$$\frac{C_A}{C_B} = \frac{\frac{1}{4} \times K_A \times V_A}{\frac{1}{4} \times K_B \times V_B} = \frac{K_A V_A}{K_B V_B}$$

End of Solution

Q.11 Two curves of gradients, g_1 and g_2 are merging such that $g_1 < g_2$ and g_1 is not equal to g_2 and not equal to zero...

- (i) $+g_1$ and $+g_2$ are making sag vertical curve
 - (ii) $-g_1$ and $-g_2$ are making sag vertical curve
 - (iii) $+g_1$ and $-g_2$ are making crest vertical curve
- Which of these statements is/are correct?

Ans. (Statement (i) and (iii) are correct.)

Condition for summit curve;

+ve to +ve; +ve to flat

$$(g_1 > g_2)$$

+ve to -ve; -ve to -ve

$$(g_1 < g_2)$$

Condition for valley curve,

-ve to -ve; -ve to flat

$$(g_1 > g_2)$$

-ve to +ve; +ve to +ve

$$(g_1 < g_2)$$

End of Solution

SURVEYING ENGINEERING

Q.12 To find the R.L of hilltop instrument readings were taken from P and Q . The distance between P and Q is 55 m and all the points lie in the same vertical plane.

Station	Vertical angle of top of hillock	Staff reading on B.M	R.L of BM
P	$18^\circ 45'$	2.340 m	100.000 m
Q	$12^\circ 45'$	1.660 m	

The R.L. of hill top is _____ m.

Ans. (137.627)

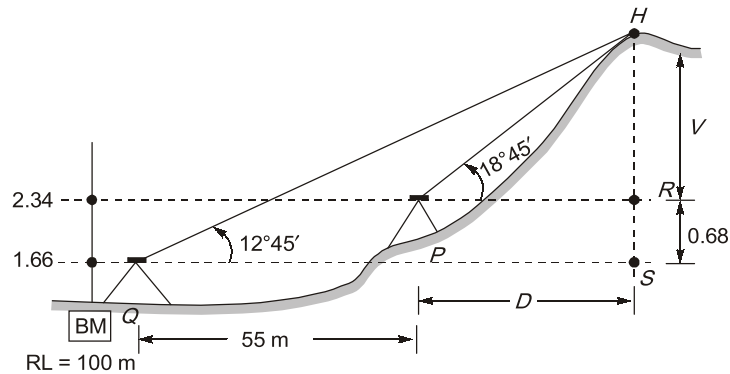

$$\text{Now, } \tan 12^\circ 45' = \frac{v + 0.68}{D + 55} \quad \dots(i)$$

$$\text{Also, } \tan 18^\circ 45' = \frac{v}{D} \quad \dots(ii)$$

On solving (i) and (ii), we get

$$v = 35.287 \text{ m}$$

$$D = 103.954 \text{ m}$$

$$\begin{aligned} \text{Now, R.L. of hill top} &= \text{R.L. of BM} + 2.34 + v \\ &= 100 + 2.34 + 35.287 = 137.627 \text{ m} \end{aligned}$$

End of Solution

STRENGTH OF MATERIAL

Q.13 Consider the following beam subjected to moments as shown in figure.

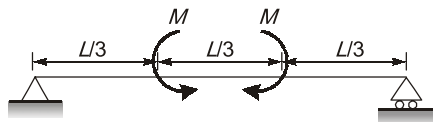

Which of the following statement(s) is/are correct?

- (a) Shear force is zero everywhere
- (b) Reaction is zero
- (c) Bending moment is zero everywhere
- (d) Deflection is zero

[MSQ]

Ans. (a, b)

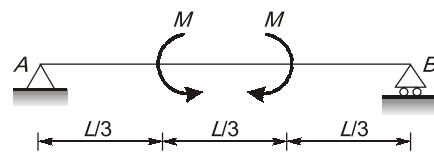

$$\sum F_y = 0$$

$$\therefore V_A + V_B = 0 \quad \dots(i)$$

$$\Sigma M_A = 0$$

$$\Rightarrow V_B \times L - M + M = 0$$

$$\therefore V_B = 0$$

from equation (i), we get

$$V_A = 0$$

\therefore shear force is zero everywhere in the beams, and reactions are also zero.

Bending moment diagram is shown below

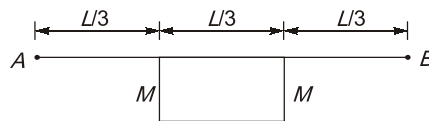

So, bending moment is not zero everywhere. Also deflection is not zero everywhere.

End of Solution

- Q.14** The infinitesimal element shown in the figure (not to scale) represents the state of stress at a point in a body. What is the magnitude of the maximum principle stress (in N/mm^2 in integer) at the point is (Round off to nearest integer)

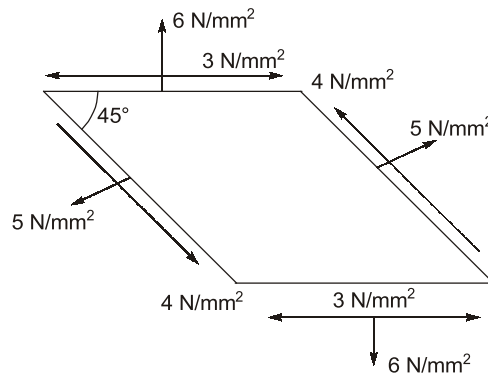

Ans. (-3)

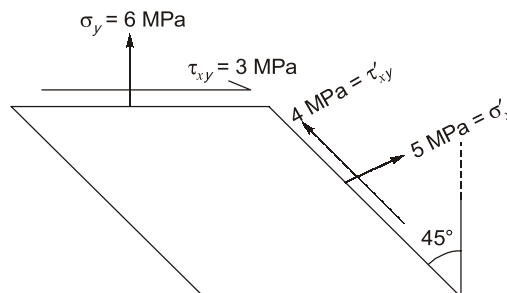

Now, $\sigma'_x = \sigma_x \cos^2 \theta + \sigma_y \sin^2 \theta + \tau_{xy} \sin 2\theta \quad \dots(i)$

here $\theta = 45^\circ$

$$\sigma'_x = 5 \text{ MPa}$$

$$\begin{aligned}\sigma_y &= 6 \text{ MPa} \\ \tau_{xy} &= 3 \text{ MPa} \\ \text{from eq. (i), we get, } \sigma_x &= -2 \text{ MPa} \\ \text{Now, } \sigma_{1/2} &= \frac{\sigma_x + \sigma_y}{2} \pm \frac{1}{2} \sqrt{(\sigma_y - \sigma_x)^2 + 4\tau_{xy}^2} \\ &= \frac{-2 + 6}{2} \pm \frac{1}{2} \sqrt{(6 + 2)^2 + 4 \times 3^2} \\ \sigma_1 &= 7 \text{ MPa} \\ \sigma_2 &= -3 \text{ MPa}\end{aligned}$$

End of Solution

- Q.15** A hanger is made of two bars of different sizes. Each bar has a square cross-section. The hanger is loaded by three-point loads in the mid vertical plane as shown in the figure. Ignore the self weight of the hanger. What is the maximum tensile stress in N/mm² anywhere in the hanger without considering stress concentration effects?

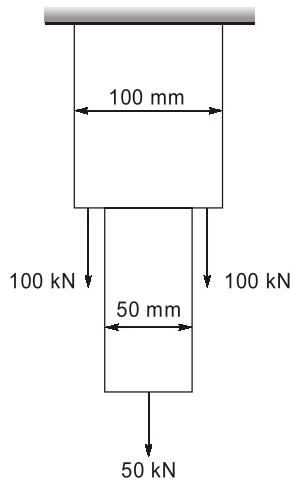

- (a) 25.0 (b) 35.0
(c) 45.0 (d) 15.0

Ans. (a)

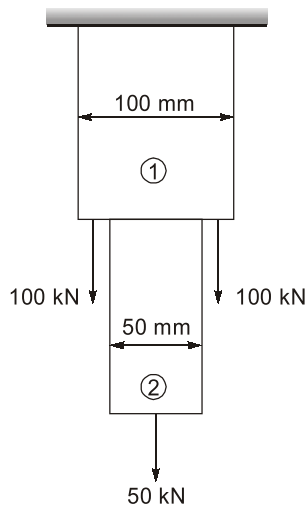



Conventional Questions Practice Programme for ESE & State Services Exams

Commencing from
1st March, 2023

Teaching Hours :
300 to 350 hours

Course Duration :
100 days

**OFFLINE
& ONLINE
COURSE**

Streams :
CE, ME, EE, EC

Key Features

- ✓ In-depth discussion on conventional questions.
- ✓ Beneficial to develop numerical question-solving techniques.
- ✓ Helps to improve answer writing & presentation skills.
- ✓ Discussion on probable questions.
- ✓ Updated Mains workbook with wide range of practice questions.
- ✓ ESE Mains test series will be conducted on every Sunday in synchronization with the subjects.

Note : Offline classes will be conducted at Delhi Centre.

Delhi Centre : 44 - A/1, Kalu Sarai, Near Hauz Khas Metro Station, New Delhi - 110016 | **Ph :** 9021300500

MADE EASY Centres : Delhi | Hyderabad | Jaipur | Bhopal | Lucknow | Bhubaneswar | Pune | Kolkata | www.madeeasy.in

Stress in member (1),

$$(\sigma_1) = \frac{P_1}{A_1} = \frac{250 \times 10^3}{100 \times 100} = 25 \text{ N/mm}^2$$

Stress in member (2),

$$(\sigma_2) = \frac{P_2}{A_2} = \frac{50 \times 10^3}{50 \times 50} = 20 \text{ N/mm}^2$$

$$\therefore \sigma_{\max} = 25 \text{ N/mm}^2$$

End of Solution

GEOTECHNICAL + OCF

- Q.16** A hydraulic jump occurs in a from wide horizontal, frictionless, rectangular channel, with a prejump depth of 0.2 m and post jump depth of 1.0 m. The value of g may be taken of 10 m/s^2 . The value of specific force per meter width at the pre jump and post jump section is same and is equal to (in m^3/m).

Ans. (3.02)

Given, $y_1 = 0.2 \text{ m}$, $y_2 = 1 \text{ m}$
As we know

$$\frac{2q^2}{g} = y_1 y_2 (y_1 + y_2)$$

$$\Rightarrow \frac{2q^2}{9.81} = 0.2 \times 1 (0.2 + 1)$$

$$\Rightarrow q^2 = \frac{9.81}{2} \times 0.2 \times 1.2$$

$$q = 1.085 \text{ m}^3/\text{s/m}$$

Now, specific force = $\frac{Q^2}{Ag} + A\bar{y}$

$$= \frac{q^2 B^2}{B^2 y_1^2 g} + \frac{B y_1 y_1}{2}$$

$$= \left(\frac{1.085^2}{0.2^2 \times 9.81} + \frac{0.2^2}{2} \right) \times B = 0.32B = 3.02 \text{ B}$$

So, Specific force per unit width = $3.02 \text{ m}^3/\text{m}$

End of Solution

- Q.17** Statements are given regarding the compaction curve. Select which of the following statements are INCORRECT?
- With increase in compactive effort, OMC decreases.
 - With increase in compactive effort, $\gamma_{d,\max}$ increases.
 - Peak of compaction curve, gives the value of $\gamma_{d,\max}$ and OMC.
 - Compaction curve crosses zero-air void line.

Ans. (d)

Zero air void line do not cross compaction curve.

End of Solution

Q.18 A drained direct shear test was carried out on a sandy soil. Under a normal stress of 50 kPa, the test specimen failed at a shear stress of 35 kPa. The angle of internal friction of the sample is _____ degree (rounded off to the nearest integer)

Ans. (35)

Given, Normal stress, $\sigma_x = 50$ kPa

Shear stress, $\tau = 35$ kPa

$$\tau = c + \sigma_n \tan \phi$$

$$\Rightarrow 35 = 50 \tan \phi \quad (\because C = 0, \text{ sandy soil})$$

$$\Rightarrow \tan \phi = 0.7$$

$$\Rightarrow \phi = 35^\circ$$

End of Solution

Q.19 The specific gravity of a soil is 2.60. The soil is 50% saturated with a water content of 15%. The void ratio of the soil is

(a) 0.87

(b) 1.28

(c) 0.78

(d) 0.35

Ans. (0.78)

Given: Specific gravity, $G = 2.6$

Saturation, $S = 0.5$

Water content, $w = 0.15$

As we know

$$Se = Gw$$

$$\Rightarrow 0.5 \times e = 2.6 \times 0.15$$

$$\Rightarrow e = \frac{2.6 \times 0.15}{0.5} = 0.78$$

End of Solution

Q.20 A group of 9 friction piles are arranged in a square grid maintaining equal spacing in all direction. Each pile is of diameter 300 mm and length 7 m. Assume that the soil is cohesionless with effective friction angle $\phi = 32^\circ$. What is the centre to centre spacing of the piles (in m) for the piles group efficiency of 60%?

(a) 0.587

(b) 0.486

(c) 0.391

(d) 0.677

Ans. (a)

By converse – Labarre formula

$$\eta_g = \left[1 - \frac{\theta}{90} \left(\frac{m(n-1) + n(m-1)}{mn} \right) \right] \times 100$$

$$\Rightarrow 0.6 = 1 - \frac{\theta}{90} \left(\frac{3 \times 2 + 3 \times 2}{3 \times 3} \right)$$

$$\Rightarrow \frac{\theta}{90} \left(\frac{6+6}{9} \right) = 0.4$$

$$\Rightarrow \theta = 27^\circ$$

Now, $\tan \theta = \frac{d}{S}$ where d is diameter and S is spacing.

So, Spacing, $S = \frac{d}{\tan \theta} = \frac{0.3}{\tan 27^\circ} = 0.587$

End of Solution

- Q.21** A smooth vertical retaining wall supports lagesed soils is shown in figure. A/c to Rankine each pressure theory, the lateral active each pressure acting at the base of the wall is kPa.

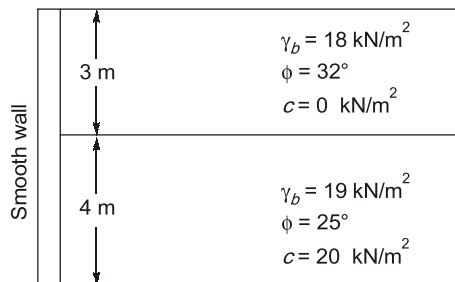

Ans. (27.29)

Active earth pressure at base,

$$\therefore \sigma = k_a (\gamma_z + q) - 2C\sqrt{k_a}$$

where, $k_a = \frac{1 - \sin \phi}{1 + \sin \phi} = \frac{1 - \sin 25^\circ}{1 + \sin 25^\circ} = 0.406$

$$q = 18 \times 3 = 54 \text{ kN/m}^2$$

$$\gamma_z = 19 \times 4 = 76 \text{ kN/m}^2$$

$$C = 20 \text{ kN/m}^2 \quad [\because \text{Given}]$$

So,
$$\sigma = 0.406 \times (76 + 54) - 2 \times 20 \times \sqrt{0.406}$$

$$= 27.29 \text{ kN/m}^2$$

End of Solution

- Q.22** The supercritical stream enters the mild sloped (M) channel section, what would be the type of profile?

- (a) M1 + M2 (b) M1
(c) M1 (d) M3

Ans. (d)

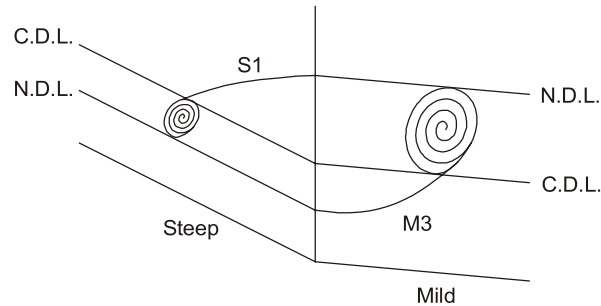

End of Solution

Q.23 Consider that force P is acting on the surface of a half-space (Boussineq's problem). The expression for the vertical stress (σ_z) at any point (r, z) is given as

$$\sigma_z = \frac{3P}{2\pi} \cdot \frac{z^3}{(r^2 + z^2)}$$

where r is the radial distance and z is the depth with downward direction taken as positive. At any given r , there is a variation of σ_z along z . The locus of the maximum σ_z is

(a) $z^3 = \frac{3}{2}r^2$

(b) $z^2 = \frac{5}{2}r^2$

(c) $z^3 = \frac{5}{2}r^2$

(d) $z^2 = \frac{3}{2}r^2$

Ans. (d)

At given r

For maximum σ_z

$$\frac{d\sigma_z}{dz} = 0$$

$$\sigma_z = \frac{3P}{2\pi} \frac{z^3}{(r^2 + z^2)^{5/2}}$$

$$\Rightarrow \frac{d\sigma_z}{dz} = \frac{3P}{2\pi} \left[\frac{(r^2 + z^2)^{5/2} \cdot 3z^2 - z^3 \cdot \frac{5}{2} (r^2 + z^2)^{3/2} \cdot 2z}{(r^2 + z^2)^5} \right] = 0$$

$$\Rightarrow (r^2 + z^2)^{3/2} z^2 [3(r^2 + z^2) - 5z^2] = 0$$

$$\Rightarrow 3r^2 + 3z^2 - 5z^2 = 0$$

$$\Rightarrow 3r^2 = 2z^2$$



Rank Improvement Course for **GATE 2024**

Commencing from
1st May, 2023

Teaching Hours :
300 to 350 hours

Course Validity :
Till GATE 2024 Exam

**LIVE-ONLINE
COURSE**

Streams :
CE, ME, EE, EC, CS

Key Features

- ✓ Comprehensive problem-solving sessions by India's top faculties.
- ✓ Focus on improving accuracy & speed.
- ✓ Practice all types of questions to brush up on your concepts.
- ✓ Newly develop workbooks (e-copy) in line with recent trends in GATE.
- ✓ Highly useful for repeaters candidates.

**Download
the App**



Android



iOS

 **9021300500**

 **www.madeeasyprime.com**

$$\Rightarrow z^2 = \frac{3r^2}{2}$$

End of Solution

Q.24 A vertical trench is excavated in a clayey soil deposit having a surcharge load of 30 kPa. A fluid of unit-weight is 12 kN/m³ is poured in the trench to prevent collapse as the excavation proceeds. Assume that the fluid is not seeping through the soil deposit. If the undrained cohesion of the clay deposit is 20 kPa and saturated unit weight is 18 kN/m³, what is the maximum depth of unsupported excavation (in m, round off to two decimal).

Ans. (3.33)

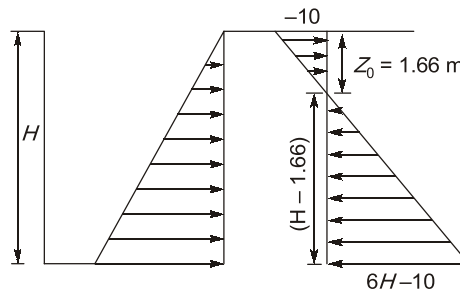

Now, active pressure at depth z ,

$$\sigma_z = k_a \gamma z - 2C\sqrt{k_a} - 12z + k_q$$

At $z = 0$

[$\because k = 1$ for $\phi = 0^\circ$, $q = 30$ kN/m²; $C = 20$ kN/m²]

$$\begin{aligned}\sigma_z &= -2 \times C + q = 2 \times 20 + 30 \\ &= -40 + 30 \\ &= -10 \text{ kN/m}^2\end{aligned}$$

At z_0 , $\sigma_z = 0$

$$18z_0 - 40 - 12z_0 + 30 = 0$$

$$\Rightarrow 6z_0 - 10 = 0$$

$$\Rightarrow z_0 = 1.66 \text{ m}$$

At depth H , $\sigma_H = k_a \gamma H - 2C\sqrt{k_a} - 12H + k_q$

$$\begin{aligned}\text{So, } \sigma_H &= 18H - 40 - 12H + 30 \\ &= 6H - 10\end{aligned}$$

For unsupported depth of excavation, total active thrust must be zero.

$$\text{So, } \frac{1}{2} \times 10 \times 1.66 = \frac{1}{2} \times (H - 1.66) \times (6H - 10)$$

$$\Rightarrow H = \frac{10}{3} = 3.33 \text{ m}$$

End of Solution

Q.25 Match **List-I** (Cross sectional element on failure surface) with **List-II** (Test to be performed for analysis) and select the correct answer using the codes given below the lists:

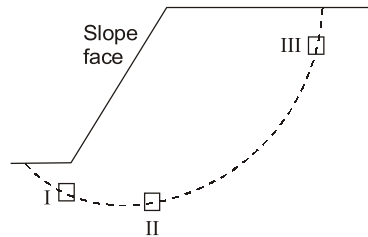

- List-I**
1. I
 2. II
 3. III

- List-II**
- P. Triaxial compression
 - Q. Triaxial extension
 - R. Direct shear
 - S. Vane shear

Ans.

I → R, II → P, III → S

End of Solution

Q.26 A soil formation with average bulk density, $\gamma_b = 19 \text{ kN/m}^2$, and $\phi = 25^\circ$, and $C = 15 \text{ kPa}$, lies on a rock slope existing at 35° . The critical height of soil formation upto which it would be stable is _____.

Ans. (5.03)

For critical height of slope

$$C + \gamma H_C \cos^2 \beta \tan \phi = \gamma H_C \sin \beta \cos \beta$$

$$\text{So, } 15 + 19 \times H_C \times \cos^2 35^\circ \tan 25^\circ = 19 \times H_C \times \sin 35^\circ \cos 35^\circ$$

$$\Rightarrow H_C = 5.03 \text{ m}$$

End of Solution

ENGINEERING MATHEMATICS

Q.27 $I = \int_{-1}^1 \frac{1}{x^2} dx$ which of the following statement is true?

- (a) $I = 2$
- (b) The integral does not converge
- (c) $I = 0$
- (d) $I = -2$

Ans. (b)

$$f(x) = \frac{1}{x^2} \text{ is not defined at } x = 0$$

$$\begin{aligned} \text{So, } I &= \int_{-1}^0 \frac{1}{x^2} dx + \int_0^1 \frac{1}{x^2} dx \\ &= \left(-\frac{1}{x} \right)_{-1}^0 + \left(-\frac{1}{x} \right)_0^1 \end{aligned}$$

$\frac{1}{x}$ is not defined at $x = 0$

Therefore, the integral does not converge.

End of Solution

Q.28 In the differential equation $\frac{dy}{dx} + \alpha xy = 0$, α is a positive constant. $y = 1.0$ at $x = 0.0$ and $y = 0.8$ at $x = 1.0$, the value of α is _____.

Ans. (0.446)

Given, $\frac{dy}{dx} + \alpha xy = 0$

Using variable separable method.

$$\int \frac{dy}{y} = -\alpha \int x dx + \log C$$

$$y = C e^{-\frac{\alpha}{2} x^2}$$

By putting $y(0) = 1$

we get $C = 1$

By putting $y(1) = 0.8$

$$e^{-\frac{\alpha}{2}} = 0.8$$

$$\alpha = -2 \log 0.8 = 0.446$$

End of Solution

Q.29 $A = \begin{bmatrix} 1 & 2 & 3 \\ 3 & 2 & 1 \\ 3 & 1 & 2 \end{bmatrix}$ which of the following is/are true?

- (a) Eigen values of A^T and A are same.
- (b) Eigen vectors of A and A^T are same.
- (c) Eigen value of A^{-1} is reciprocal of Eigen value of A .
- (d) Eigen value of A^{-1} and A^T are same.

Ans. (a, b, c)

Eigen values of A^T and A are same.

Eigen vectors of A and A^T are same.

Eigen values of A^{-1} is reciprocal of Eigen value of A .

\therefore Option (d) is not correct.

End of Solution



Live-Online Classes for **SSC-JE 2023**

Batches are live

Validity: **Till 31st July, 2023**

**TECHNICAL &
NON-TECHNICAL
SYLLABUS**

Streams :
CE, ME, EE

Course Details

CE Only Technical	ME Only Technical	EE Only Technical	Non-Tech (RA + GS)
Teaching Hrs : 650 Hrs	Teaching Hrs : 450 Hrs	Teaching Hrs : 300 Hrs	Teaching Hrs : 260 Hrs
Total No. of Books : 16	Total No. of Books : 15	Total No. of Books : 10	Total No. of Books : 03

Key Features

- ✓ Live Classes by experienced and renowned faculties having experience in SSC-JE field.
- ✓ Systematic subject sequence for Paper-I and Paper-II.
- ✓ Comprehensive coverage of Technical & Non-technical syllabus for Prelims & Mains.
- ✓ Well-researched study materials.
- ✓ Facility of watching video thrice, i.e., 1 Live session + 2 Recorded sessions.

📞 **9021300500**

🌐 **www.madeeasyprime.com**

Q.30 The differential equation $\frac{du}{dt} + 2tu^2 = 1$ is solved by employing a backward difference scheme within the finite difference framework. The value of u at the $(n - 1)^{\text{th}}$ time-step, for some n is 1.75. The corresponding time (t) is 3.14s. Each time step is 0.01s long. Then, the value of $(U_n - U_{n-1})$ is _____. (round off to three decimal).

Ans. (- 0.182)

Given differential equation

$$\frac{du}{dt} + 2tu^2 = 1$$

$$\frac{du}{dt} = f(t, u) = 1 - 2tu^2$$

$$u_n = u_{n-1} + hf(t_n, u_n)$$

$$u_n - u_{n-1} = h[1 - 2t_n u_n^2]$$

Given, $h = 0.01$, $u_n = 1.75$, $t_n = 3.14$

Putting these value we get

$$= - 0.182$$

End of Solution

Q.31 $f(x) = e^x |\sin x|$

(a) Periodic

(b) Bounded

(c) Continuous

(d) Differentiable

Ans. (c)

Given:

$$f(x) = e^x |\sin x|$$

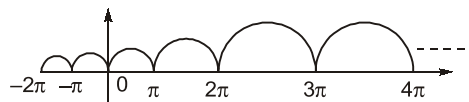

By observing graph we can easily say given function is not periodic, not bounded and not differentiable.

End of Solution

Q.32 If $f(x) = px^4 + qx^5$; $[-l, l]$ and its Fourier series expansion is

$$f(x) = a_0 + \sum_{n=1}^{\infty} b_n \cos\left(\frac{n\pi x}{l}\right) + \sum_{n=1}^{\infty} a_n \sin\left(\frac{n\pi x}{l}\right)$$

Then which statements is/are false?

(a) a_n depends upon p

(b) a_n depends on q

(c) b_n depends upon p

(d) b_n depends on q

- Q.34** Consider a doubly reinforced RCC beam with the option of using either Fe 250 plain bars or Fe 500 deformed bars in the compression zone. The modulus of elasticity of steel is 2×10^5 N/mm². As per IS456 : 2000, in which types (s) of the bars, the stress in the compression steel (F_{sc}) can reach the design strength ($0.87 f_y$) at the limit state of collapse?
- (a) Fe 250 plain bars only.
 - (b) Neither Fe250 plain bars nor Fe500 deformed bars.
 - (c) Both Fe250 plain bars and Fe500 deformed bars.
 - (d) Fe 500 deformed bars only.

Ans. (a)

End of Solution

- Q.35** Creep of concrete under compression is defined as the
- (a) decrease in the magnitude of strain under constant stress
 - (b) increase in the magnitude of strain under constant stress
 - (c) decrease in the magnitude of stress under constant strain
 - (d) increase in the magnitude of strain under constant stress

Ans. (b)

Increase in magnitude of strain under constant stress.

End of Solution

ENGINEERING MECHANICS

- Q.36** The cross-section of a girder is as shown in figure (not to scale). The section is symmetric about a vertical axis (Y-Y). The moment of inertia of the section about the horizontal axis (X-X) passing through the centroid is ____ cm⁴. (round off to nearest integer).

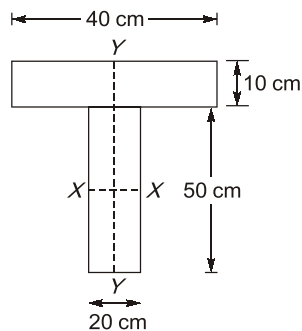

Ans. (468810)

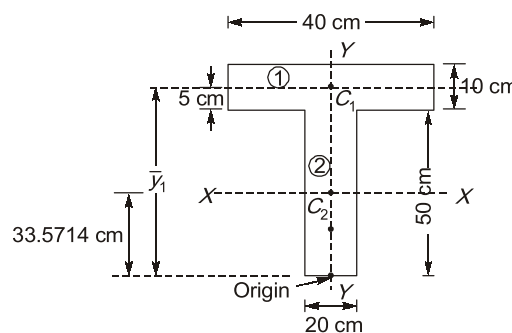

$$A_1 = 40 \times 10 = 400 \text{ cm}^2$$

$$A_2 = 20 \times 50 = 1000 \text{ cm}^2$$

$$\bar{y}_1 = 50 + 5 = 55 \text{ cm}$$

$$\bar{y}_2 = \frac{50}{2} = 25 \text{ cm}$$

Centroid of composite shape, from bottom fibre,

$$\bar{y} = \frac{A_1\bar{y}_1 + A_2\bar{y}_2}{A_1 + A_2}$$

$$\bar{y} = \frac{(400 \times 55) + (1000 \times 25)}{400 + 1000}$$

$$\bar{y} = 33.5714 \text{ cm}$$

$$I_{xx} = \left[\frac{40 \times 10^3}{12} + 400(\bar{y}_1 - \bar{y})^2 \right] + \left[\frac{20 \times 50^3}{12} + 1000(\bar{y} - \bar{y}_2)^2 \right]$$

$$= \left[\frac{40 \times 10^3}{12} + 400(55 - 33.5714)^2 \right] + \left[\frac{20 \times 50^3}{12} + 1000(33.5714 - 25)^2 \right]$$

$$= 187007.2925 + 281802.2313$$

$$I_{xx} = 468809.5238 \text{ cm}^4 \simeq 468810 \text{ cm}^4$$

End of Solution

ENVIRONMENTAL ENGG.

- Q.37** Identify the waterborne diseases caused by viral pathogens.
- (a) Acute anterior poliomyelitis (b) Infectious hepatitis
(c) Typhoid fever (d) Cholera

Ans. (a, b)

End of Solution

- Q.38** The composition of a Municipal solid waste is shown in table below. The moisture content of the MSW is 26%. The energy derived from the dry weight of the MSW is

Components	%Mass	Energy content [MJ/kg]
Food waste	20%	4.5
Paper	45%	16
Card board	5%	14
Plastic	10%	32
Other	20%	8



Live-Online Course for **General Studies** for **State Engineering** and **SSC Exams**

**FULL
FLEDGED
COURSE FOR
GENERAL
STUDIES**

Subject Covered : History, General Science, Polity, Environment, Geography, General Knowledge, Economy & Current Affairs

Duration : 3 Months | **Validity :** 6 Months

Batches commencing from **22nd Feb, 2023**

Key Features

- ✓ 250 Hrs of quality teaching by renowned teachers of MADE EASY.
- ✓ Printed study material will be dispatched to your address.
- ✓ Comprehensive coverage as per latest syllabus and trends of various competitive exams.

Ans. (18.38)

Energy content (as discarded basis):

$$[0.2 \times 4.5 + 0.45 \times 16 + 0.05 \times 14 + 0.1 \times 32 + 0.2 \times 8]$$

$$= 13.6 \text{ MJ/kg}$$

Energy content (on dry basis) for moisture content of 26%:

$$= \frac{13.6 \text{ MJ/kg} \times 100\%}{(100 - 26)\%} = 18.38 \text{ MJ/kg}$$

End of Solution

Q.39 The waste water inflow to an activated sludge plant is $0.5 \text{ m}^3/\text{s}$, and the plant is to be operated with a food to micro-organism ratio of 0.2 mg/mg-d . The concentration of influent biodegradable organic matter of the waste water to the plant (after primary settling) is 150 mg/L and the mixed liquor volatile suspended solid concentration to be maintained in the plant is 2000 mg/L . Assuming that complete removal of biodegradable organic matter in the tank, the volume of aeration tank required for the plant is _____ m^3 . (in integer).

Ans. (16200)

Given: $Q = 0.5 \text{ m}^3/\text{sec}$

$$\frac{F}{M} = 0.2 \text{ mg/mg-d}$$

$$S_0 = 150 \text{ mg/L}$$

$$X = 2000 \text{ mg/L}$$

Now,
$$\frac{F}{M} = \frac{Q_0 S_0}{V \cdot X}$$

$$0.2 \text{ d}^{-1} = \frac{0.5 \frac{\text{m}^3}{\text{sec}} \times 86400 \frac{\text{sec}}{\text{d}} \times 150 \frac{\text{mg}}{\text{L}}}{v \times 2000 \frac{\text{mg}}{\text{L}}}$$

$$v = 16200 \text{ m}^3$$

End of Solution

Q.40 Which of the following is true about RDF (Refuse derived fuel)?

- (a) RDF can be in powdered form
- (b) HHV (High heat value) of unprocessed MSW is lesser than HHV of RDF
- (c) RDF can't be used in conjunction with oil
- (d) Inorganic fraction of MSW is mostly converted to RDF.

Ans. (a, b, c)

End of Solution

Q.41 Match the following:

- | | |
|----------------------|----------------------------------|
| (P) Reverse osmosis | (I) Ponding |
| (Q) Trickling filter | (II) Freundlich isotherm |
| (R) Coagulation | (III) Concentration polarization |
| (S) Adsorption | (IV) Charge neutralization |

Ans.

P – III, Q – I, R – IV, S – II.

End of Solution

Q.42 Volume of tank = 280 m³. Power is same

Case1: Temp = 15°C – $\mu = 1.139 \text{ N-s/m}^2$, $G = 100 \text{ sec}^{-1}$

Case2: Temp = 5°C – $\mu = 1.518 \text{ N-s/m}^2$, $G = ??$

Determine % change in G .

Ans. (13.38)

$$G_1 = \sqrt{\frac{P}{\mu_1 \times V}} \quad \dots(i)$$

$$G_2 = \sqrt{\frac{P}{\mu_2 \times V}} \quad \dots(ii)$$

Divide (i) by (ii), we get

$$\frac{G_1^2}{G_2^2} = \frac{\mu_2}{\mu_1}$$

$$G_2^2 = \left[\frac{(100 \text{ s}^{-1})^2 \times 1.139 \times 10^{-3} \text{ N-s/m}^2}{1.518 \times 10^{-3} \text{ N-s/m}^2} \right]^{1/2} = 86.62 \text{ S}^{-1}$$

$$\% \text{ change in } G = \frac{G_1 - G_2}{G_1} \times 100 = \frac{100 - 86.62}{100} \times 100 = 13.38\%$$

End of Solution

FLUID MECHANICS

Q.43 A jet of water having a velocity of 20 m/s strikes a series of plates fixed radially on a wheel revolving in the same direction as the jet at 15 m/s. What is the % efficiency of the plates? (round off to one decimal)

- | | |
|----------|----------|
| (a) 66.7 | (b) 88.9 |
| (c) 37.5 | (d) 50.0 |

Ans. (c)

Given:

$$v_1 = 20 \text{ m/s}$$

$$u = 15 \text{ m/s}$$

$$[u_1 = u_2 = u]$$

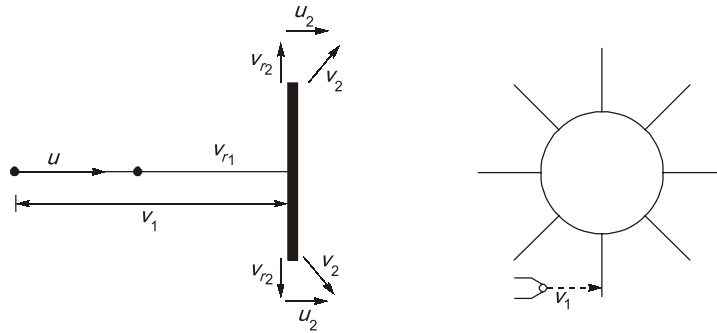

$$\begin{aligned} \text{Efficiency, } \eta &= \frac{\text{Work done per second}}{\text{Input water power}} \\ &= \frac{F_x \cdot u}{\frac{1}{2} \dot{m} V_1^2} = \frac{\dot{m} [V_1 - u] \times u}{\frac{1}{2} \dot{m} V_1^2} \\ &= \frac{[20 - 15] \times 15}{\frac{1}{2} \times (20)^2} = 0.375 \approx 37.5\% \end{aligned}$$

End of Solution

STRUCTURAL ANALYSIS

- Q.44** Consider the pin jointed truss shown in figure (not to scale). All member have same axial rigidity, AE . Member QR , RS and ST have same length L . Angle QBT , RCT , SDT are all 90° . Angle of BQT , CRT , DST are all 30° . The joint T carries a vertical load P . The vertical deflection of joint T is $k \frac{PL}{AE}$. The value of k is ____.

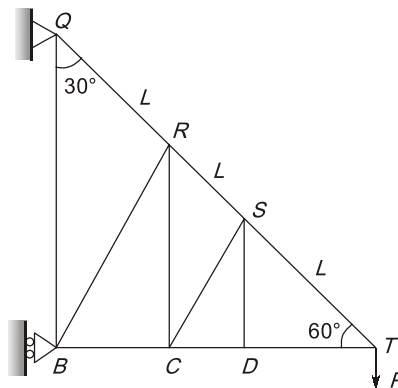

- (a) 9
(b) 1.5
(c) 4.5
(d) 13.6

Ans. (c)

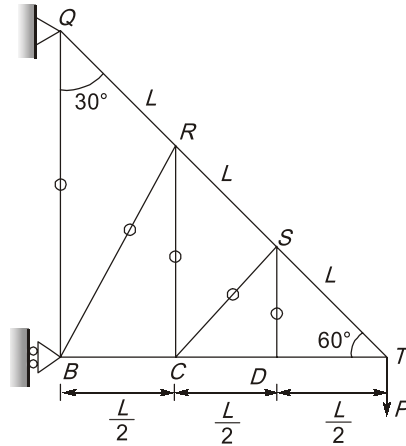

At joint T,

$$\Rightarrow \begin{aligned} \Sigma F_y &= 0 \\ F_{TS} \sin 60^\circ &= P \end{aligned}$$

$$F_{TS} = \frac{2P}{\sqrt{3}} (T)$$

$$\Sigma F_x = 0 \\ F_{TS} \cos 60^\circ = F_{DT}$$

$$F_{DT} = \frac{2P}{\sqrt{3}} \left(\frac{1}{2}\right) = \frac{P}{\sqrt{3}} (C)$$

$$F_{TS} = F_{SR} = F_{RQ} = \frac{2P}{\sqrt{3}} (T)$$

$$F_{DT} = F_{CD} = F_{BL} = \frac{P}{\sqrt{3}} (C)$$

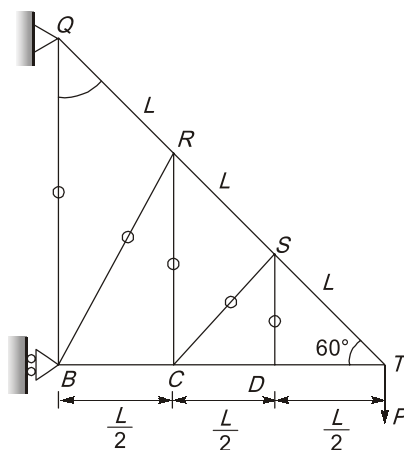
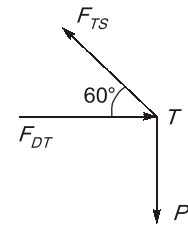

Similarly,

$$F_{ST} = F_{SR} = F_{RS} = F_{AQ} = \frac{2P}{\sqrt{3}} (T)$$

$$\therefore \delta_{VT} = \sum \frac{PkL}{AE} = \frac{\left(\frac{2P}{\sqrt{3}}\right)\left(\frac{2}{\sqrt{3}}\right)L \times 3}{AE} + \frac{\left(\frac{P}{\sqrt{3}}\right)\left(\frac{1}{\sqrt{3}}\right)\frac{L}{2} \times 3}{AE}$$

$$\delta_{VT} = \frac{4PL}{AE} + \frac{PL}{2AE} = \frac{4.5PL}{AE}$$

$$\Rightarrow k = 4.5$$

End of Solution

Q.45 An idealised bridge truss is shown in the figure. The force in member U_2L_3 is

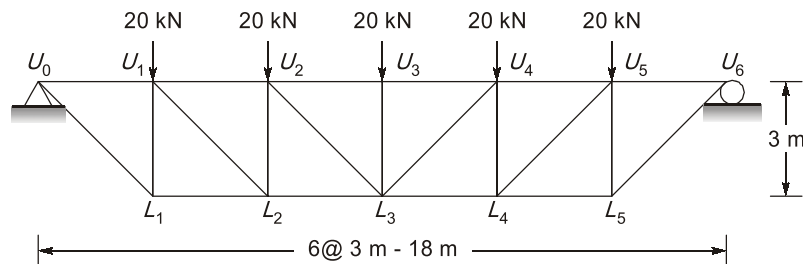

- (a) # (b) #
(c) # (d) $10\sqrt{2}$ kN (Tension)

Ans. (d)

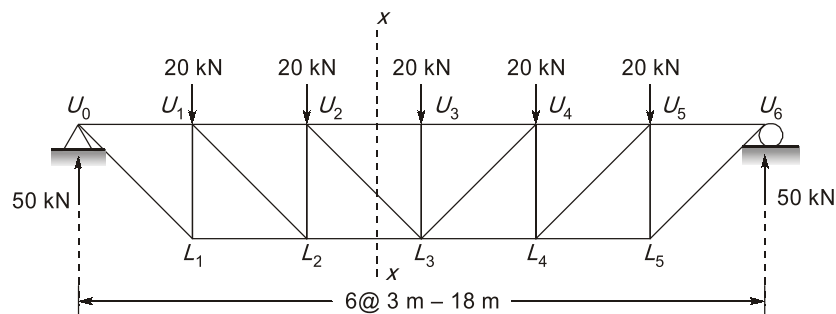

Reactions at supports:

Because of symmetry vertical reaction at supports

$$= \frac{100}{2} = 50 \text{ kN}$$

Applying method of sections and taking the section as shown in the figure above,

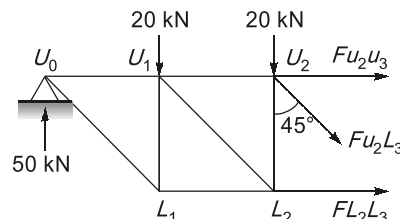

$$\sum F_y = 0$$

$$\Rightarrow Fu_2L_3 \cos 45^\circ + 20 + 20 - 50 = 0$$

$$F_{u2-3} \cos 45^\circ = 10$$

$$F_{u2-3} = 10\sqrt{2} \text{ kN (Tension)}$$

End of Solution

Q.46 Consider the following structures as shown below:

- I. Beam with hinge support at A, roller at C, guided roller at E and internal hinges at B and D.
- II. Pin jointed truss with hinge support at A and rollers at B and D.
- III. Pin-jointed truss with hinge support at A and roller at C.

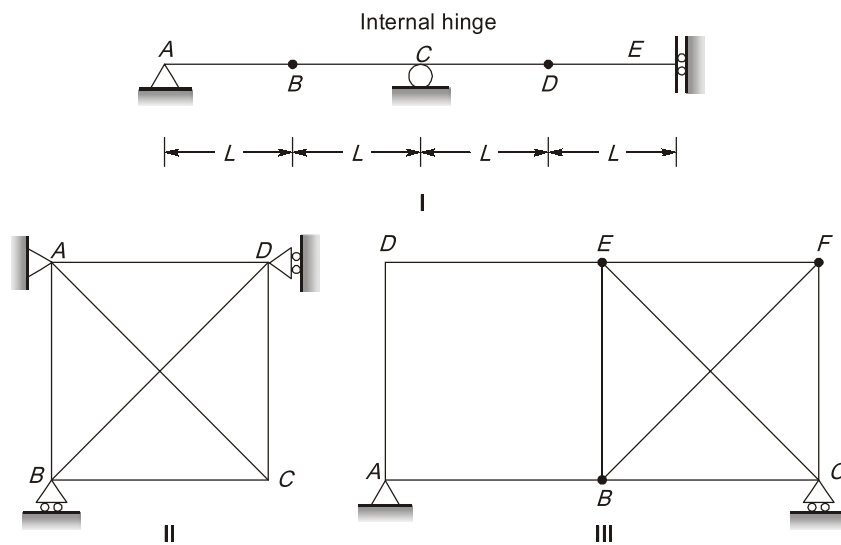

Which of the following structure is/are stable?

- (a) # (b) #
(c) # (d) #

Ans.

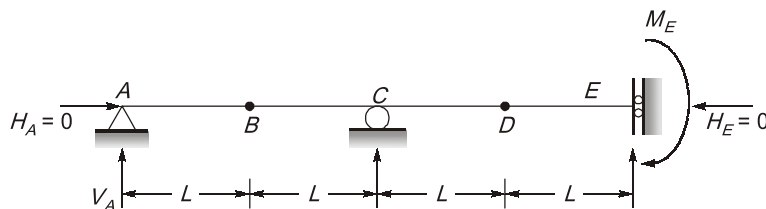

$$r = 3 (V_A, V_C, M_E)$$

$$s = 4 (\sum F_y = 0, \sum M = 0, BM_B = 0, BM_D = 0)$$

$$D_s = r - s = 3 - 4 = -1$$

\Rightarrow negative implies unstable

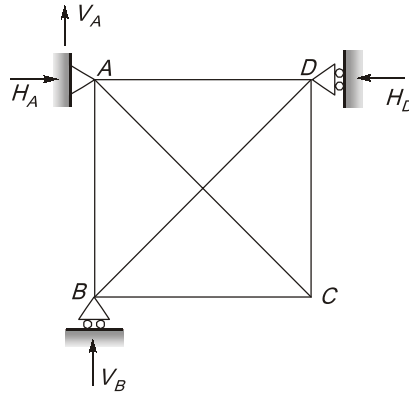

Rigid body rotation is possible since all the four reactions are concurrent at A.
Unstable,

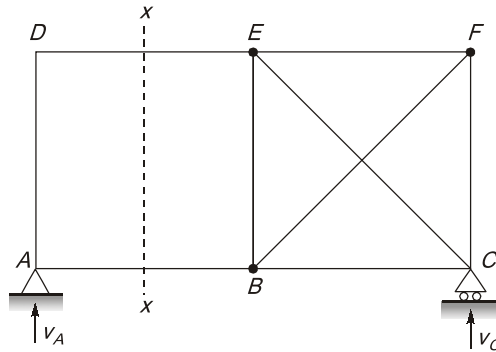

Shear force at $x-x$ = Panel shear force = V_A
There is no member to resist panel shear force.
So unstable.

End of Solution

Design of Steel Structures

Q.47 Consider the horizontal axis passing through the centroid of the steel beam cross section shown in figure. What is the shape factor (rounded off to one decimal place) for the cross section?

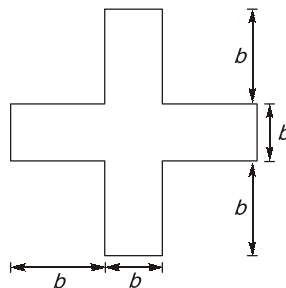

- (a) 1.7
- (b) 1.3
- (c) 2.0
- (d) 1.5

Ans. (a)
As we know,

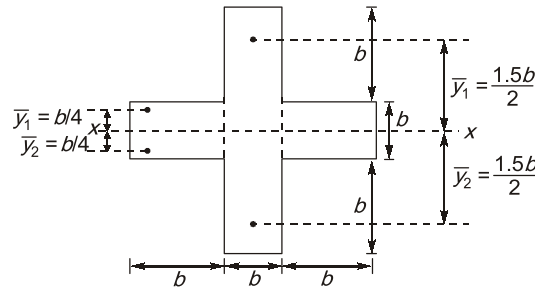

$$z_p = \frac{A}{2} [\bar{y}_1 + \bar{y}_2]$$

$$= (6 \times 1.5b) \left[\frac{1.5b}{2} + \frac{1.5b}{2} \right] + \left[2b \times \frac{b}{2} \right] \times \left[\frac{b}{4} + \frac{b}{4} \right] = 2.75b^3$$

$$z = \frac{I_{xx}}{y} = \frac{\left[\frac{b \times (3b)^3}{12} + \frac{2b \times b^3}{12} \right]}{1.5b} = \frac{29}{18} b^3$$

Shape factor, $S.F. = \frac{z_p}{z} = \frac{2.75b^3}{\frac{29}{18} b^3} = 1.7$

End of Solution

Q.48 Consider the following welded arrangement shown below. The welding is done at 90° and the size of the weld is 8 mm. If the permissible stress in the weld is 120 MPa, then the maximum load that can be safely transferred is

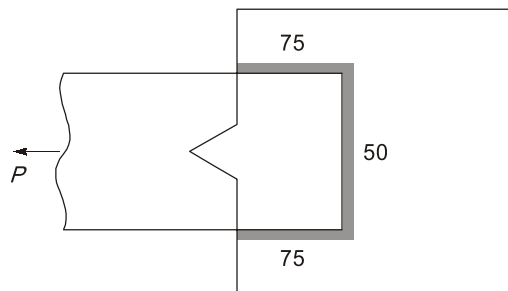

All dimensions in mm

Ans. (134.4)

Given: $S = 8 \text{ mm}$, $\tau_{vw} = 120 \text{ MPa}$, $L_w = 2 \times 75 + 50 = 200 \text{ mm}$
The safe load is calculated as per WSM

$$\begin{aligned} \therefore \rho_{\text{safe}} &= \tau_{vw} \times A_w \\ &= \tau_{vw} \times L_w \times (0.7 \times s) \quad [\because t_t = 0.7s] \\ &= 120 \times [2 \times 75 + 50] \times 0.7 \times 8 \times 10^{-3} \text{ kN} = 134.4 \text{ kN} \end{aligned}$$

End of Solution

HYDROLOGY ENGG.

Q.49 The ordinates of a 1-hour unit hydrograph for a catchment are given below :

t (hr)	0	1	2	3	4	5	6	7
Q (m ³ /sec)	0	9	21	18	12	5	2	0
		3	10					

Using the principle of superposition a D-hr UH for a catchment was derived from the 1-hr UH. The ordinate of the D hr UH where obtained as 3 m³/sec at $t = 1$ hr and 10 m³/s at $t = 2$ hr., the value of 'D' (integer) is _____.

Ans. (3)

Time	1hr-UH	1hr UH lagged by 1 hr	1hr-UH lagged by 1 more hr	3 hr DRH	$\left(\frac{\text{Col.5}}{3\text{hr}}\right)$ hr UH
(1)	(2)	(3)	(4)	(5)	
0	0	-	-	0	0
1	9	0	-	9	3
2	21	9	0	30	10
3	18	21	9	48	16
4	12	18	21	51	17
5	5	12	18	35	11.67
6	2	5	12	19	6.33
7	0	2	5	7	2.33
		0	2	2	0.67
			0	0	0

- Firstly lag the UH by 1 hr. By lagging 1 hr. We obtained a 2 hr UH of ordinate 4.5 m³/sec. at 1 hr and 15 m³/sec at 2 hr.
- So, further lag the UH by 1 more hr we obtained a 3 hr, UH of ordinates 3 m³/sec at 1 hr and 10 m³/sec at 2 hr. Therefore $D = 3$ hr.

End of Solution

Q.50 In Horton's equation fitted to the infiltration data for a soil, the initial infiltration capacity is 10 mm/h; final infiltration capacity is 5 mm/h; and the exponential decay constant is 0.5/h. Assuming that the infiltration takes place at capacity rates, the total infiltration depth (in mm) from a uniform storm of duration 12h is _____ (round off to one decimal place).

Ans. (70)

Initial infiltration capacity, $f_0 = 10$ mm/h

Final infiltration capacity, $f_f = 5$ mm/h

Decay constant, $k = 0.5/h$

Now,

$$f_T = \int_0^T [f_f + (f_0 - f_f)e^{-kt}] dt$$

$$= \int_0^{12} (5 + (10 - 5)e^{-0.5t}) dt$$

$$= [5t]_0^{12} + \left[\frac{5e^{-0.5t}}{(-0.5)} \right]_0^{12}$$

$$= [5 \times 12] + [-10e^{-0.5 \times 12} - [-10e^{-0.5 \times 0}]]$$

$$= 60 + [9.975]$$

$$= 69.97 \text{ mm} \approx 70 \text{ mm}$$

End of Solution

- Q.51** A 12 hour storm occurs over a catchment and results in a direct runoff depth of 100 mm. The time distribution of the rainfall intensity is shown in the figure (not to scale). The ϕ -index of the storm is (in mm round off to two decimal) is _____.

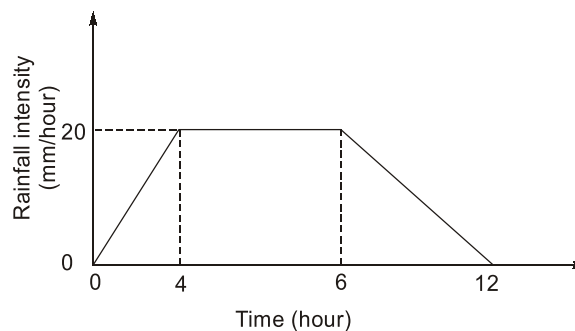

Ans. (3.6)

Given: Time = 12 hr
Runoff = 100 mm
Total depth of precipitation,

$$P = \frac{1}{2}[20 \times 4] + 2 \times 20 + \frac{1}{2} \times 20 \times 6 = 140 \text{ mm}$$

No, $W\text{-Index} = \frac{P - R}{t} = \frac{140 - 100}{12} = 3.33 \text{ mm/hr}$

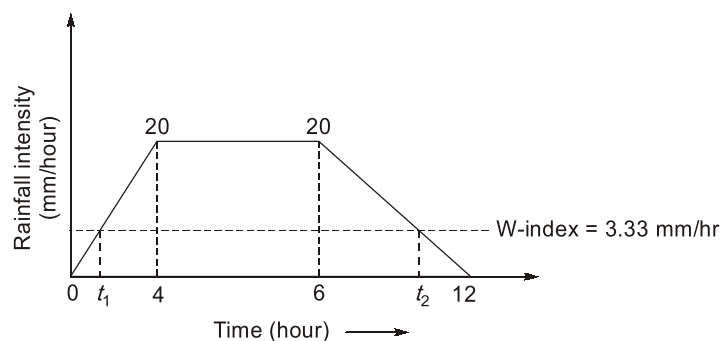

$$\text{Now, } \frac{20}{4} = \frac{3.33}{t_1}$$

$$\Rightarrow t_1 = 0.67 \text{ hr}$$

$$\text{Similarly, } \frac{20}{6} = \frac{3.33}{t_2}$$

$$\Rightarrow t_2 = 0.99 \text{ hr}$$

$$\begin{aligned} \text{Now, } \phi\text{-Index} &= \frac{140 - \left[\frac{1}{2} \times 3.33 \times 0.67 + \frac{1}{2} \times 3.33 \times 0.99 \right]}{12 - 0.67 - 0.99} \\ &= 3.6 \text{ mm/hr} \end{aligned}$$

End of Solution

IRRIGATION

Q.52 A canal is used to irrigate area of 1000 ha for growing wheat. The time between first and last watering is 120 days, depth of water required is 35 cm. Intense watering is required for 30 days and depth of water required is 12 cm. Neglecting all other losses, calculate the minimum discharge required in the canal in m³/sec.

Ans. (0.46)

Given: Area : 1000 ha

Total depth of water, $\Delta_2 = 35$ cm

Total time period, $B_2 = 120$ days

Kor depth, $\Delta_1 = 12$ cm

Kor period, $B_1 = 30$ days

$$(i) \quad \text{Kor duty, } \Delta_1 = \frac{8.64 \times B_1}{\Delta_1} = \frac{8.64 \times 30}{0.12} = 2160 \text{ ha/m}^3/\text{sec}$$

$$\text{Corresponding discharge} = \frac{\text{Area}}{\text{Duty}} = \frac{1000}{2160} = 0.46 \text{ m}^3/\text{sec}$$

$$(ii) \quad \text{Overall duty, } \Delta_2 = \frac{8.64 \times B_2}{\Delta_2} = \frac{8.64 \times 120}{0.35} = 2962.28 \text{ ha/m}^3/\text{sec}$$

$$\text{Corresponding discharge} = \frac{\text{Area}}{\text{Duty}} = \frac{1000}{2962.28} = 0.34 \text{ m}^3/\text{sec}$$

Minimum discharge required will be maximum of the above two.

$$\therefore Q_{\text{req.}} = 0.46 \text{ m}^3/\text{sec}$$

End of Solution

CONSTRUCTION MATERIAL

- Q.53** Choose the correct statement regarding the water-cement ratio of concrete
- (a) With increase in water cement ratio, the workability increases and compressive strength decreases.
 - (b) With increase in water cement ratio, the workability decreases and compressive strength increases.
 - (c) With increase in water cement ratio, both workability and compressive strength decreases.
 - (d) With increase in water cement ratio, both workability and compressive strength increases.

Ans. (a)

