

NARAYANA GRABS
THE LION'S SHARE IN JEE-ADV.2022

5 RANKS in OPEN CATEGORY
ONLY FROM NARAYANA
IN TOP 10 AIR



JEE MAIN (APRIL) 2023 (10-04-2023-AN)

Memory Based Question Paper
PHYSICS



PHYSICS

SECTION - A

Multiple Choice Questions: This section contains 20 multiple choice questions. Each question has 4 choices (1), (2), (3) and (4), out of which **ONLY ONE** is correct.

Choose the correct answer:

- Following circuit contains diodes with forward bias having resistance 25Ω and reverse bias having infinite resistance. The ratio of $\frac{I_2}{I_1}$ is equal to

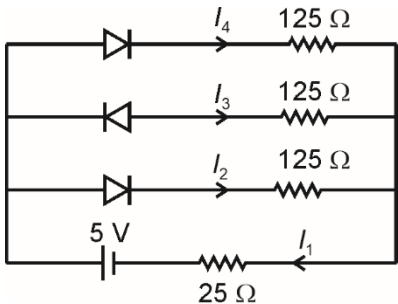

- | | |
|-------|-------|
| (1) 1 | (2) 2 |
| (3) 2 | (4) 4 |

Answer (2)

Sol. $I_2 = I_4$

$I_3 = 0$

and $I_2 + I_4 + I_3 = I_1$

$\Rightarrow I_2 = \frac{I_1}{2}$

- An object moves x distance with speed v_1 and next x distance with speed v_2 . The average velocity v is related to v_1 and v_2 as

(1) $v = \left(\frac{v_1 + v_2}{2}\right)$ (2) $\frac{1}{v} = \frac{1}{v_1} + \frac{1}{v_2}$

(3) $v = \left(\frac{2v_1v_2}{v_1 + v_2}\right)$ (4) $v = \left(\frac{v_1 - v_2}{2}\right)$

Answer (3)

Sol. $v = \frac{2x}{\left(\frac{x}{v_1} + \frac{x}{v_2}\right)} = \left(\frac{2v_1v_2}{v_1 + v_2}\right)$

- An infinitely-long conductor has a current 14 A flowing as shown:

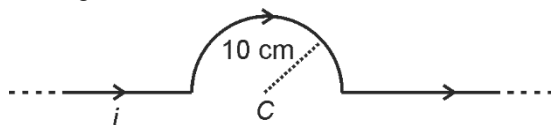

Find magnetic field at centre C.

- | | |
|----------------------|-----------------------|
| (1) $88 \mu\text{T}$ | (2) $44 \mu\text{T}$ |
| (3) $10 \mu\text{T}$ | (4) $120 \mu\text{T}$ |

Answer (2)

Sol. $B = \frac{\mu_0 i}{4R}$
 $= \frac{4\pi \times 10^{-7} \times 14}{4 \times 0.1} \text{ T}$
 $= \frac{22}{7} \times 10^{-7} \times 140 \text{ T}$
 $= 44 \mu\text{T}$

- A point object (O) is placed on the principal axis of a system of two lenses as shown. Find the distance between the final image and object.

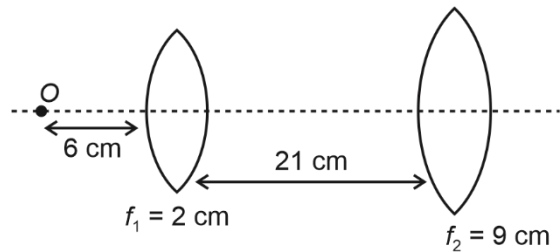

- | | |
|-----------|-----------|
| (1) 45 cm | (2) 40 cm |
| (3) 55 cm | (4) 50 cm |

Answer (1)

Sol. From lens (1) $\frac{1}{v} - \frac{1}{(-6)} = \frac{1}{2} \Rightarrow v = 3 \text{ cm}$

From lens (2) $\frac{1}{v'} - \frac{1}{(-18)} = \frac{1}{9} \Rightarrow v' = +18 \text{ cm}$

Distance between O and I = $6 + 21 + 18 = 45 \text{ cm}$

- Based on given graph between stopping potential and frequency of irradiation, work function of metal is equal to

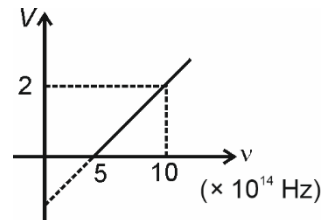

- | | |
|----------|----------|
| (1) 1 eV | (2) 3 eV |
| (3) 2 eV | (4) 4 eV |

Answer (3)

Sol. $eV_s = h\nu - \phi$

On extrapolating the graph, the graph cuts the y-axis at -2

\Rightarrow at $\nu = 0, V_s = -2 \text{ V}$

$\Rightarrow \phi = 2 \text{ eV}$

JEE (Main)-2023 : Phase-2 (10-04-2023)-Evening

6. **Assertion (A):** Fan spins even after switch is in OFF.

Reason (R): Fan in rotation has rotational inertia.

- (1) A is correct and R is correct explanation of A
 (2) A and R both are correct but R is not correct explanation of A.
 (3) A is correct and R is incorrect
 (4) Both A and R are incorrect

Answer (1)

7. Wire A and B have their Young's moduli in the ratio 1 : 3, area of cross-section in the ratio of 1 : 2 and lengths in ratio of 3 : 4. If same force is applied on the two wires to elongate then ratio of elongation is equal to

- (1) 8 : 1 (2) 1 : 12
 (3) 1 : 8 (4) 9 : 2

Answer (4)

Sol. $\frac{\Delta l_A}{\Delta l_B} = \frac{F l_A / A_A Y_A}{F l_B / A_B Y_B} = \left(\frac{Y_B}{Y_A}\right) \left(\frac{A_B}{A_A}\right) \left(\frac{l_A}{l_B}\right)$
 $= \left(\frac{3}{1}\right) \left(\frac{2}{1}\right) \left(\frac{3}{4}\right) = \left(\frac{9}{2}\right)$

8. If half life for a radio-active decay reaction is T. Find the time after which $\frac{7}{8}$ th of initial mass decays.

- (1) 3T (2) 2T
 (3) $\frac{T}{2}$ (4) 4T

Answer (1)

Sol. $\therefore t_{1/2} = T$

also, $m_0 \xrightarrow{T} \frac{m_0}{2} \xrightarrow{T} \frac{m_0}{4} \xrightarrow{T} \frac{m_0}{8}$

total time taken is 3T.

9. When electric field is applied to the electrons in a conductor it starts

- (1) Moving in straight line
 (2) Drifting from higher potential to lower potential
 (3) Drifting from lower potential to higher potential
 (4) Moving with constant velocity

Answer (3)

Sol. Electron starts drifting from lower potential to higher potential.

10. A metallic slab of thickness $\frac{2d}{3}$ and area of surface same as that of plates of capacitor of capacitance C_1 is inserted parallel to plates of capacitor such that its new capacitance becomes equal to C_2 . If d is space width between the two plates, then $\frac{C_2}{C_1}$ is equal to

- (1) 1 (2) 2
 (3) 3 (4) 4

Answer (3)

Sol. $C_2 = \frac{C_1 d}{\left(d - \frac{2d}{3}\right)}$

$\frac{C_2}{C_1} = 3$

11. Consider two statements:

Statement 1: Magnetic susceptibility of diamagnetic substance is $-1 \leq x < 0$.

Statement 2: Diamagnetic substance moves from stronger to weaker magnetic field.

- (1) Both statements are correct
 (2) Both are incorrect
 (3) Statement 1 is correct and statement 2 is incorrect
 (4) Statement 1 is incorrect and statement 2 is correct

Answer (1)

Sol. For diamagnetic, $\mu_r < 1$

$\Rightarrow -1 \leq x < 0$

Also, diamagnetic material moves from stronger to weaker fields.

12. In communication of a message signal, if frequency of message signal and carrier signal are 3 kHz and 6 MHz respectively. Then, amplitude modulated signal will have bandwidth of

- (1) 12 MHz (2) 6 kHz
 (3) 3 kHz (4) 6 MHz

Answer (2)

Sol. Bandwidth of AM signal = $2 f_m$

$= 2 \times 3 \text{ kHz} = 6 \text{ kHz}$

13. In standard YDSE phase difference between two rays reaching at points P and Q is $\frac{\pi}{3}$ and $\frac{\pi}{2}$ respectively. Ratio of resultant intensity at P and Q is equal to

- (1) $\frac{3}{2}$ (2) $\frac{2}{3}$
 (3) $\frac{1}{4}$ (4) $\frac{1}{2}$

Answer (1)

Sol. $I = I_0 \cos^2\left(\frac{\Delta\phi}{2}\right)$

$$\Rightarrow \frac{I_P}{I_Q} = \frac{\cos^2\left(\frac{\Delta\phi_P}{2}\right)}{\cos^2\left(\frac{\Delta\phi_Q}{2}\right)}$$

$$= \frac{\frac{3}{4}}{\frac{1}{2}} = \frac{3}{2}$$

14. Two projectiles A and B are projected from the same point on ground with same speed of projection as shown. Find the ratio of maximum height attained by A to that of B.

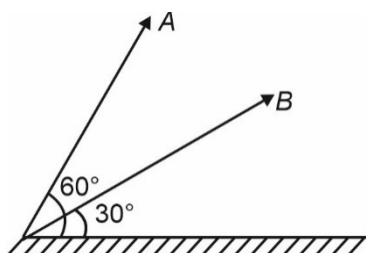

- (1) 3 : 1 (2) 1 : 3
(3) $\sqrt{3} : 1$ (4) $\sqrt{3} : 2$

Answer (1)

Sol. $\frac{h_A}{h_B} = \frac{\frac{u^2 \sin^2 60^\circ}{2g}}{\frac{u^2 \sin^2 30^\circ}{2g}} = \frac{3}{1}$

15. Force acting on a particle at origin is $\vec{F} = -c\hat{k}$. The torque of this force about $(-2, 3, 0)$ is $-c(A\hat{i} + B\hat{j})$.

If $\frac{A}{B} = \frac{x}{2}$, find x.

- (1) $\frac{2}{3}$ (2) 3
(3) 1.5 (4) 1

Answer (3)

Sol. $\vec{\tau} = \vec{r} \times \vec{F}$

$$= (2\hat{i} + 3\hat{j}) + (-c\hat{k})$$

$$= 2c\hat{j} + 3c\hat{i}$$

$$= c(3\hat{i} + 2\hat{j})$$

$$\Rightarrow \frac{A}{B} = 1.5$$

16. If time period for one revolution by satellite near the earth's surface is T . Then the time period of revolution of satellite at a height equal to radius of earth will be

- (1) $\sqrt{8T}$
(2) $\sqrt{2T}$
(3) $\sqrt{4T}$
(4) $\sqrt{3T}$

Answer (1)

Sol. $\therefore T^2 \propto r^3$

$$\left(\frac{T}{T'}\right)^2 = \left(\frac{R}{2R}\right)^3$$

$$T' = \sqrt{8T}$$

17. In a mixture 0.5 moles of O_2 and 4 moles of Ne gas are taken at temperature T . The internal energy of the system is equal to

- (1) $\left(\frac{13}{2}\right)RT$
(2) $\left(\frac{11}{4}\right)RT$
(3) $\left(\frac{29}{4}\right)RT$
(4) $\left(\frac{13}{4}\right)RT$

Answer (3)

Sol. $U = U_{O_2} + U_{Ne}$

$$= \frac{5}{2}n_{O_2}RT + \frac{3}{2}n_{Ne}RT$$

$$= \left(\frac{5}{4} + \frac{24}{4}\right)RT$$

18. **Assertion (A):** Acceleration due to gravity is minimum at equator.

Reason (R): Rotation of earth influences acceleration.

- (1) A is correct, R is correct explanation of A
(2) A is correct, R is incorrect explanation of A
(3) A is correct and R is incorrect
(4) Both A and R are incorrect

Answer (1)

Sol. Acceleration due to gravity depends on the rotation of earth and distance from the centre.

19. An infinite line charge of charge density λ has a charged particle $(-q, m)$ revolving about it in a circle of radius r . Find the orbital speed.

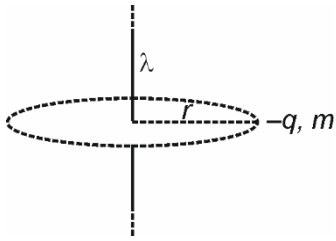

- (1) $\sqrt{\frac{\lambda a}{\pi \epsilon_0 m}}$
 (2) $\sqrt{\frac{\lambda q}{4 \pi \epsilon_0 m}}$
 (3) $\sqrt{\frac{4 \lambda a}{\pi \epsilon_0 m}}$
 (4) $\sqrt{\frac{\lambda q}{2 \pi \epsilon_0 m}}$

Answer (4)

Sol. $E = \frac{\lambda}{2\pi\epsilon_0 r}$

$$\Rightarrow \frac{\lambda q}{2\pi\epsilon_0 r} = \frac{mv^2}{r}$$

$$\Rightarrow v = \sqrt{\frac{\lambda q}{2\pi\epsilon_0 m}}$$

20. A gas is compressed adiabatically. Which of the following statements is not correct?

- (1) Internal energy is constant
 (2) Temperature increases
 (3) |Work done| = |Change in internal energy|
 (4) Heat is not supplied to the system

Answer (1)

Sol. $\Delta Q = \Delta U + W$

For adiabatic, $\Delta Q = 0 \dots(1)$

Also, since compression $\Rightarrow T$

$\Rightarrow U$ increases.

SECTION - B

Numerical Value Type Questions: This section contains 10 questions. In Section B, attempt any five questions out of 10. The answer to each question is a **NUMERICAL VALUE**. For each question, enter the correct numerical value (in decimal notation, truncated/rounded-off to the second decimal place; e.g., 06.25, 07.00, -00.33, -00.30, 30.27, -27.30) using the mouse and the on-screen virtual numeric keypad in the place designated to enter the answer.

21. Frictional force acts on the lift of mass 1400 kg is 2000 N. If lift moves with constant velocity of 3 m/s in upward direction, the power (in kW) of motor is (take $g = 10 \text{ m/s}^2$)

Answer (48)

Sol. $\uparrow F = \text{Force by motor}$

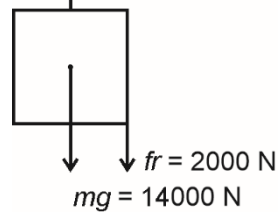

$$P = F.V$$

$$= 16000 \times 3$$

$$= 48000 \text{ watt} = 48 \text{ kW}$$

22. If the angular frequency of the given motion is $k\omega$, find the value of k

$$y = \sin(\omega t) + \cos \omega t$$

Answer (1)

Sol. $y = \sqrt{2} \left[\sin(\omega t) \cdot \cos\left(\frac{\pi}{4}\right) + \cos(\omega t) \sin\left(\frac{\pi}{4}\right) \right]$

$$= \sqrt{2} \sin\left(\omega t + \frac{\pi}{4}\right)$$

Angular frequency = ω

23.
 24.
 25.
 26.
 27.
 28.
 29.
 30.