



Andhra Pradesh State Council of Higher Education

Notations :

- 1.Options shown in **green** color and with  icon are correct.
- 2.Options shown in **red** color and with  icon are incorrect.

Question Paper Name :	Instrumentation Engineering 29th Sep 2021 Shift1
Duration :	120
Total Marks :	120
Display Marks:	No
Share Answer Key With Delivery Engine :	Yes
Calculator :	None
Magnifying Glass Required? :	No
Ruler Required? :	No
Eraser Required? :	No
Scratch Pad Required? :	No
Rough Sketch/Notepad Required? :	No
Protractor Required? :	No
Show Watermark on Console? :	Yes
Highlighter :	No
Auto Save on Console? (SA type of questions will be always auto saved) :	Yes
Is this Group for Examiner? :	No

Instrumentation Engineering

Section Id :	8737182
Section Number :	1
Mandatory or Optional :	Mandatory
Number of Questions :	120
Section Marks :	120
Enable Mark as Answered Mark for Review and Clear Response :	Yes

Question Number : 1 Question Id : 873718121 Display Question Number : Yes Is Question Mandatory : No

Find voltage V_J from the below network?

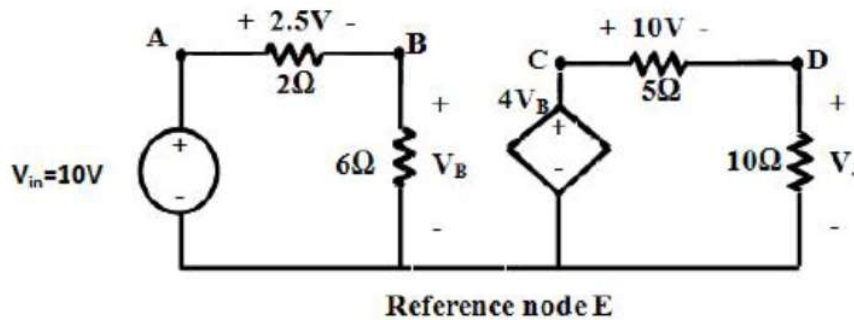

Options :

1. ✓ 20V
2. ✗ 15V
3. ✗ 9V
4. ✗ -20V

Question Number : 2 Question Id : 873718122 Display Question Number : Yes Is Question

Mandatory : No

Which source is delivering and which source is absorbing power from the below figure?

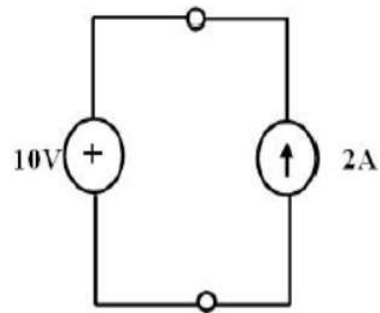

Options :

1. ✘ 10 volts source absorbing 20W, 2A source delivering -20W
2. ✘ 10 volts source absorbing -20W, 2A source delivering 20W
3. ✘ 10 volts source absorbing -20W, 2A source delivering -20W
4. ✔ 10 volts source absorbing 20W, 2A source delivering 20W

Question Number : 3 Question Id : 873718123 Display Question Number : Yes Is Question

Mandatory : No

Find the Voltage V_2 from the below network?

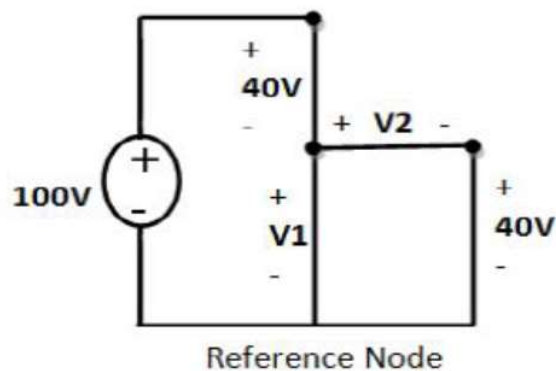

Options :

1. ✘ -20V

2. ✘ 10V

3. ✔ 20V

4. ✘ 15

Question Number : 4 Question Id : 873718124 Display Question Number : Yes Is Question Mandatory : No

Find V_x , V_o from the below network?

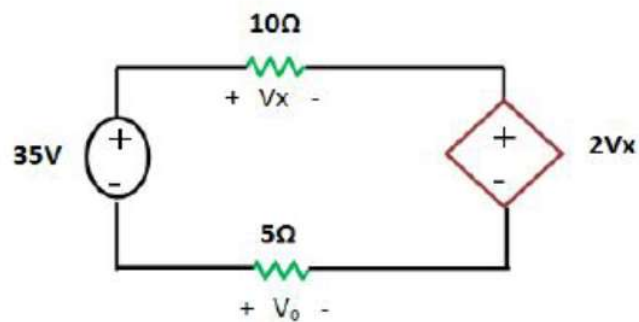

Options :

1. ✘ -10V, 5V

2. ✔ 10V, -5V

3. ✘ 8V, 10V

4. ✘ -10V, -5V

Question Number : 5 Question Id : 873718125 Display Question Number : Yes Is Question Mandatory : No

Find i_1 , i_2 and i_3 from the below network?

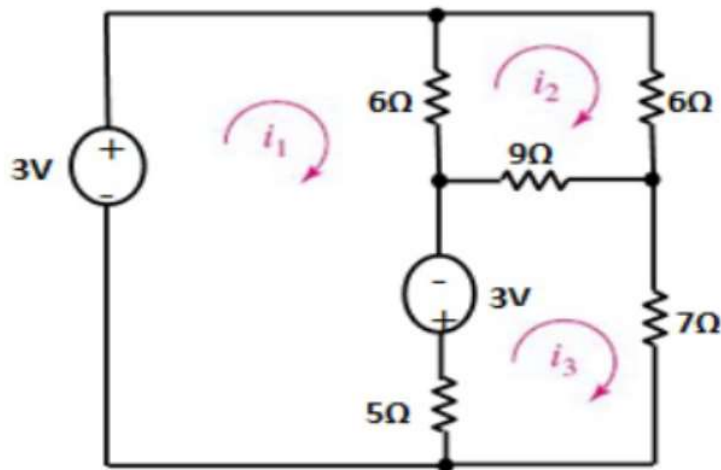

Options :

1. ✓ $i_1 = 0.989 \text{ A}$, $i_2 = 0.15 \text{ A}$, $i_3 = 0.15 \text{ A}$
2. ✗ $i_1 = -0.989 \text{ A}$, $i_2 = 0.15 \text{ A}$, $i_3 = 0.15 \text{ A}$
3. ✗ $i_1 = 0.989 \text{ A}$, $i_2 = -0.15 \text{ A}$, $i_3 = 0.15 \text{ A}$
4. ✗ $i_1 = 0.989 \text{ A}$, $i_2 = 0.15 \text{ A}$, $i_3 = -0.15 \text{ A}$

Question Number : 6 Question Id : 873718126 Display Question Number : Yes Is Question Mandatory : No

Find i_1 , i_2 and i_3 from the given network?

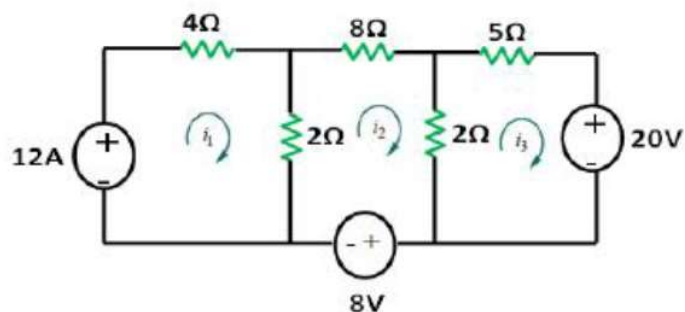

Options :

1. ✗ $i_1 = -1.7 \text{ A}$, 0.9 A , 3.11 A

2. ✘ $i_1 = -1.7\text{A}, -0.9\text{A}, 3.11\text{A}$

3. ✘ $i_1 = -1.7\text{A}, 0.9\text{A}, -3.11\text{A}$

4. ✔ $i_1 = 1.7\text{A}, -0.9\text{A}, -3.11\text{A}$

Question Number : 7 Question Id : 873718127 Display Question Number : Yes Is Question Mandatory : No

Find current I in the given network

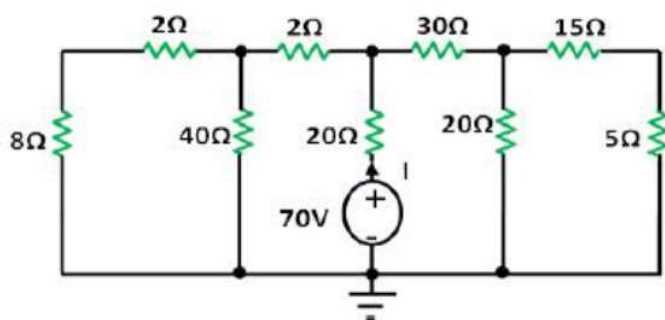

Options :

1. ✔ $I = 2.5\text{A}$

2. ✘ $I = -2.4\text{A}$

3. ✘ $I = -2.9\text{A}$

4. ✘ $I = -2.5\text{A}$

Question Number : 8 Question Id : 873718128 Display Question Number : Yes Is Question Mandatory : No

Find voltage across the current source

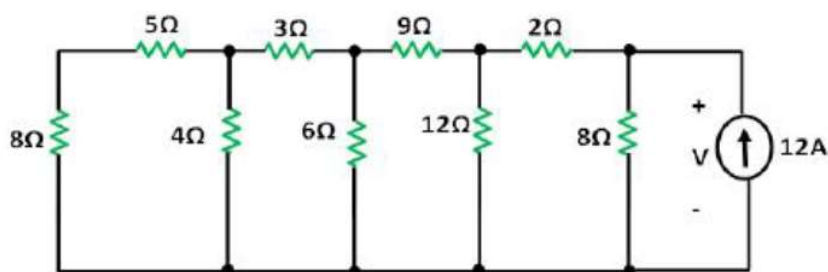

Options :

1. ✘ -48 V

2. ✘ -47 V

3. ✘ -49 V

4. ✔ 48 V

Question Number : 9 Question Id : 873718129 Display Question Number : Yes Is Question Mandatory : No

Find the voltage across the 4 ohm and 2 ohm resistors respectively

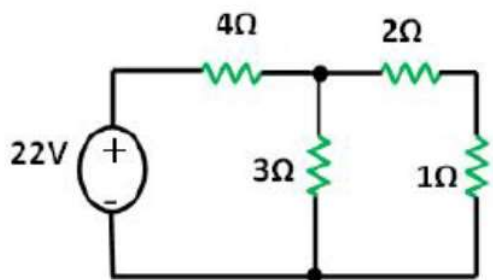

Options :

1. ✘ $-16\text{V}, -4\text{V}$

2. ✘ $-16\text{V}, 4\text{V}$

3. ✓ 16V, 4V

4. ✗ 16V, -4V

Question Number : 10 Question Id : 873718130 Display Question Number : Yes Is Question Mandatory : No

Find the current through the 10k ohm, 5k ohm in the given network

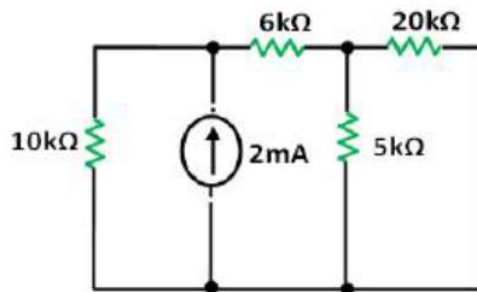

Options :

1. ✓ 1 mA, 0.8 mA

2. ✗ -1 mA , 0.8 mA

3. ✗ 1 mA, -0.8 mA

4. ✗ -1 mA, -0.8 mA

Question Number : 11 Question Id : 873718131 Display Question Number : Yes Is Question Mandatory : No

A capacitive microphone is the application of

Options :

1. ✗ Hygrometer

2. ✖ Capacitive moisture transducer
3. ✔ Capacitive displacement transducer
4. ✖ Capacitive strain transducer

Question Number : 12 Question Id : 873718132 Display Question Number : Yes Is Question Mandatory : No

Identify the active transducer in the following

Options :

1. ✔ Thermocouple
2. ✖ Thermistor
3. ✖ Strain Guage
4. ✖ LVDT

Question Number : 13 Question Id : 873718133 Display Question Number : Yes Is Question Mandatory : No

The relation between sensitivity and scale factor of a transducer is given by

Options :

1. ✖ Scale factor is double of sensitivity factor
2. ✔ Scale factor is inverse of sensitivity factor

3. ✘ Sensitivity is inverse of scale factor

4. ✘ Sensitivity is equal to scale factor

Question Number : 14 Question Id : 873718134 Display Question Number : Yes Is Question Mandatory : No

A metal with temperature coefficient of resistance has a value 200, its initial resistance is given by 40Ω . For an increase in 300°C to 350°C what will be the final resistance value?

Options :

1. ✔ $40\text{ K}\Omega$

2. ✘ $4\text{ K}\Omega$

3. ✘ $40\ \Omega$

4. ✘ $400\ \Omega$

Question Number : 15 Question Id : 873718135 Display Question Number : Yes Is Question Mandatory : No

Self-inductance of an inductor is given by

Options :

1. ✘ $L = N/S$

2. ✘ $L = 1/S$

3. ✔ $L = N^2/S$

4. ✘ $L = N^2$

Question Number : 16 Question Id : 873718136 Display Question Number : Yes Is Question Mandatory : No

In kitchen applications a piezoelectric crystal is used for

Options :

1. ✘ Skimming milk

2. ✔ Lighting a gas stove

3. ✘ Rending

4. ✘ Mixing

Question Number : 17 Question Id : 873718137 Display Question Number : Yes Is Question Mandatory : No

Piezoelectric transducer consists of

Options :

1. ✘ Copper rod

2. ✘ Aluminum wire

3. ✘ Gold crystal

4. ✔ Quartz crystal

Question Number : 18 Question Id : 873718138 Display Question Number : Yes Is Question Mandatory : No

A strain gauge is a passive transducer and is employed for converting

Options :

1. ✓ Mechanical displacement into a change of resistance
2. ✗ Pressure into a change of resistance
3. ✗ Force into a displacement
4. ✗ Pressure into displacement

Question Number : 19 Question Id : 873718139 Display Question Number : Yes Is Question Mandatory : No

Certain type of materials generates an electrostatic charge or voltage when mechanical force is applied across them. Such materials are called

Options :

1. ✓ Piezo-electric
2. ✗ Photo-electric
3. ✗ Thermo-electric
4. ✗ Photo-resistive

Question Number : 20 Question Id : 873718140 Display Question Number : Yes Is Question Mandatory : No

Pressure transducer for measuring blood pressure is

Options :

1. ✘ Strain gauge transducer only
2. ✔ Strain gauge or capacitive transducer
3. ✘ Resistive transducer
4. ✘ Fiber optic transducer

Question Number : 21 Question Id : 873718141 Display Question Number : Yes Is Question

Mandatory : No

pH value of venous blood is

Options :

1. ✘ 7.30
2. ✘ 7.40
3. ✔ 7.35
4. ✘ 7.45

Question Number : 22 Question Id : 873718142 Display Question Number : Yes Is Question

Mandatory : No

Strain gauge, LVDT and thermocouple are examples of

Options :

1. ✘ Active transducers
2. ✘ Passive transducers
3. ✔ Analog transducers
4. ✘ Primary transducers

Question Number : 23 Question Id : 873718143 Display Question Number : Yes Is Question Mandatory : No

An inverse transducer is a device which converts

Options :

1. ✔ An electrical quantity into a non electrical quantity
2. ✘ Electrical quantity into mechanical quantity
3. ✘ Electrical energy into thermal energy
4. ✘ Electrical energy into light energy

Question Number : 24 Question Id : 873718144 Display Question Number : Yes Is Question Mandatory : No

Relative humidity is:

Options :

The moisture present in a body of air expressed as a percentage of saturation at the

1. ✔ existing temperature
2. ✘ The moisture in a body of air, in grams per cubic meter

3. ✘ The temperature at which moisture will condense from a body of air

The ratio of actual moisture in a volume of air to the moisture that would exist at

4. ✘ optimum comfort in a similar volume

Question Number : 25 Question Id : 873718145 Display Question Number : Yes Is Question

Mandatory : No

When a wet and dry bulb Psychrometer is read to determine relative humidity:

Options :

1. ✘ The dry bulb will read lower than the wet bulb

2. ✘ The two thermometers may read the same

3. ✔ The wet bulb will read lower than the dry bulb

4. ✘ A formula may be employed to relate the wet bulb reading to relative humidity

Question Number : 26 Question Id : 873718146 Display Question Number : Yes Is Question

Mandatory : No

When the diode is shorted for both forward and reverse biased condition, meter reads

Options :

1. ✘ 0.2 V

2. ✘ 0.5 V

3. ✔ 0 V

4. ✘ 0.7 V

Question Number : 27 Question Id : 873718147 Display Question Number : Yes Is Question Mandatory : No

If the biasing voltage is 10 V and $R = 1.0\text{Kohm}$, then forward voltage for practical diode model will be

Options :

1. ✘ 5 V

2. ✔ 9.3 V

3. ✘ 10 V

4. ✘ 10.7 V

Question Number : 28 Question Id : 873718148 Display Question Number : Yes Is Question Mandatory : No

During diffusion, decrease in energy level of conduction band in n region is loss of ____

Options :

1. ✘ Lower energy electrons

2. ✔ Higher energy electrons

3. ✘ 1st Shell electrons

4. ✘ 2nd Shell electrons

Question Number : 29 Question Id : 873718149 Display Question Number : Yes Is Question

Mandatory : No

A small voltage drop occurs across pn region due to internal resistance of material, this small resistance is called ____

Options :

1. ✘ Static Resistance
2. ✔ Dynamic Resistance
3. ✘ Base Resistance
4. ✘ Drain Resistance

Question Number : 30 Question Id : 873718150 Display Question Number : Yes Is Question

Mandatory : No

Typical open circuit voltage for both forward and reverse biased condition is approximately

Options :

1. ✘ 0.6 V
2. ✘ 0.7 V
3. ✔ 2.6 V
4. ✘ 1.7 V

Question Number : 31 Question Id : 873718151 Display Question Number : Yes Is Question

Mandatory : No

RC coupling is used for _____ amplification

Options :

1. ✓ Voltage
2. ✗ Current
3. ✗ Power
4. ✗ Resistance

Question Number : 32 Question Id : 873718152 Display Question Number : Yes Is Question Mandatory : No

When a multistage amplifier is to amplify d.c. signal, then one must use ___ coupling.

Options :

1. ✗ RC
2. ✗ Transformer
3. ✓ Direct
4. ✗ Indirect

Question Number : 33 Question Id : 873718153 Display Question Number : Yes Is Question Mandatory : No

If a three-stage amplifier has individual stage gains of 10 db, 5 db and 12 db, then total gain in db is _____

Options :

1. ✗ 600 db

2. ✘ 24 db

3. ✘ 14 db

4. ✔ 27 db

Question Number : 34 Question Id : 873718154 Display Question Number : Yes Is Question Mandatory : No

For the operational amplifier circuit shown, the output saturation voltages are $\pm 15\text{V}$. The upper and lower threshold voltages for the circuit are, respectively,

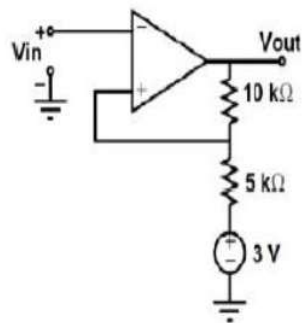

Options :

1. ✘ +5 V and -5 V

2. ✔ +7 V and -3 V

3. ✘ +3 V and -7 V

4. ✘ +3 V and -3 V

Question Number : 35 Question Id : 873718155 Display Question Number : Yes Is Question Mandatory : No

The amplifier circuit shown in the figure is implemented using a compensated operation amplifier (op-amp), and has an open-loop voltage gain, $A_0=105$ V/V and an open-loop cut-off frequency, $f_c=8$ Hz. The voltage gain of the amplifier at 15 kHz, in V/V is _____.

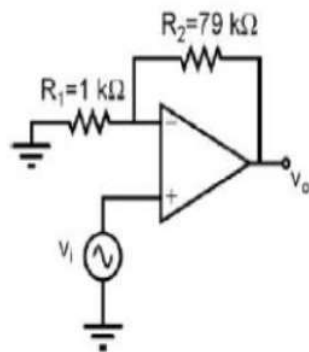

Options :

1. ✓ 43.3 to 45.3
2. ✗ 48.3 to 49.3
3. ✗ 47.3 to 49.3
4. ✗ 46.3 to 47.3

Question Number : 36 Question Id : 873718156 Display Question Number : Yes Is Question Mandatory : No

The voltage gain A_v of the circuit shown below is _____

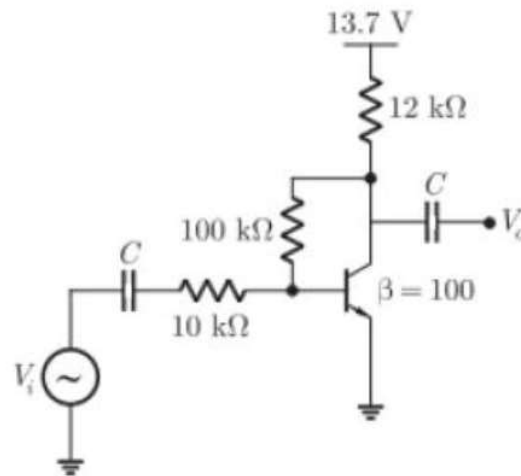

Options :

1. ✘ $|A_v| \sim 200$
2. ✘ $|A_v| \sim 250$
3. ✘ $|A_v| \sim 150$
4. ✔ $|A_v| \sim 100$

Question Number : 37 Question Id : 873718157 Display Question Number : Yes Is Question

Mandatory : No

The amplifier shown below has a voltage gain of -25, an input resistance of 10 kW, and a lower 3-dB cut-off frequency of 20 Hz. Which one of the following statements is **true** when the emitter resistance R_E is doubled?

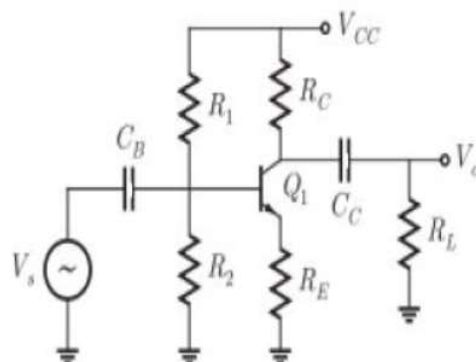

Options :

- ✘ Collector bias current will increase
- ✘ Input resistance will decrease
- ✔ Magnitude of voltage gain will decrease
- ✘ Lower 3-dB cut-off frequency will increase

Question Number : 38 Question Id : 873718158 Display Question Number : Yes Is Question Mandatory : No

The ideal opamp based circuit shown below acts as a _____

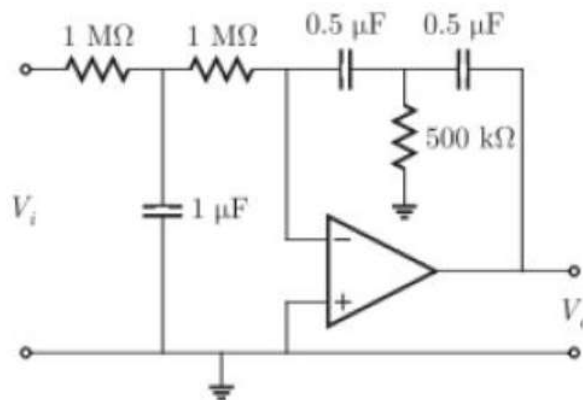

Options :

- ✘ high-pass filter
- ✘ band-pass filter
- ✘ band-reject filter
- ✔ low-pass filter

Question Number : 39 Question Id : 873718159 Display Question Number : Yes Is Question

Mandatory : No

An ideal value of stability factor is _____?

Options :

1. ✓ 1

2. ✗ 100

3. ✗ 200

4. ✗ 101

Question Number : 40 Question Id : 873718160 Display Question Number : Yes Is Question

Mandatory : No

Name the filter that has two pass bands?

Options :

1. ✗ Low pass filter

2. ✓ Band- reject filter

3. ✗ High pass filter

4. ✗ Band-pass filter

Question Number : 41 Question Id : 873718161 Display Question Number : Yes Is Question

Mandatory : No

$A(A + B) = ?$

Options :

1. ✗ AB

2. ✖ 1

3. ✖ $(1 + AB)$

4. ✔ A

Question Number : 42 Question Id : 873718162 Display Question Number : Yes Is Question Mandatory : No

De Morgan's theorem states that _____

Options :

1. ✔ $(AB)' = A' + B'$

2. ✖ $(A + B)' = A' * B$

3. ✖ $A' + B' = A'B'$

4. ✖ $(AB)' = A' + B$

Question Number : 43 Question Id : 873718163 Display Question Number : Yes Is Question Mandatory : No

_____ expressions can be implemented using either (1) 2-level AND-OR logic circuits or (2) 2-level NAND logic circuits.

Options :

1. ✖ POS

2. ✖ Literals

3. ✓ SOP

4. ✗ both POS and SOP

Question Number : 44 Question Id : 873718164 Display Question Number : Yes Is Question Mandatory : No

How much input and output needed for demultiplexer?

Options :

1. ✗ Many inputs to one output

2. ✓ One input to many outputs

3. ✗ One input to one output

4. ✗ Many inputs to many outputs

Question Number : 45 Question Id : 873718165 Display Question Number : Yes Is Question Mandatory : No

For the device shown here, let all D inputs be LOW, both S inputs be HIGH, and the \overline{EN} input be HIGH. What is the status of the Y output?

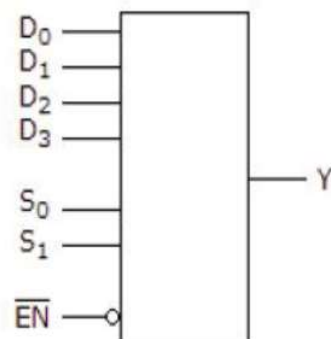

Options :

1. ✓ LOW

2. ✖ HIGH

3. ✖ Don't Care

4. ✖ Cannot be determined

Question Number : 46 Question Id : 873718166 Display Question Number : Yes Is Question Mandatory : No

How many 2:1 multiplexers are required to generate $2^n:1$ multiplexer?

Options :

1. ✖ 2^n

2. ✔ 2^n-1

3. ✖ 2^n+1

4. ✖ 2^{n-1}

Question Number : 47 Question Id : 873718167 Display Question Number : Yes Is Question Mandatory : No

Consider a 4 bit Johnson counter with an initial value of 0000. The counting sequence of this counter is:

Options :

1. ✖ 0, 1, 3, 7, 15, 14, 12, 8, 0

2. ✖ 0, 1, 3, 5, 7, 9, 11, 13, 15, 0

3. ✖ 0, 2, 4, 6, 8, 10, 12, 14, 0

4. ✔ 0, 8, 12, 14, 15, 7, 3, 1, 0

Question Number : 48 Question Id : 873718168 Display Question Number : Yes Is Question Mandatory : No

The minimum number of JK flip-flops required to construct a synchronous counter with the count sequence (0, 0, 1, 1, 2, 2, 3, 3, 0, 0,...) is _____

Options :

1. ✖ 0

2. ✖ 1

3. ✖ 2

4. ✔ 3

Question Number : 49 Question Id : 873718169 Display Question Number : Yes Is Question Mandatory : No

For a ring counter, the number of output states are always equal to _____

Options :

1. ✖ Number of input states

2. ✖ Number of clock pulses

3. ✖ Number of registers

4. ✓ Number of flip flops

Question Number : 50 Question Id : 873718170 Display Question Number : Yes Is Question Mandatory : No

Consider the given circuit. In this circuit, the race around _____

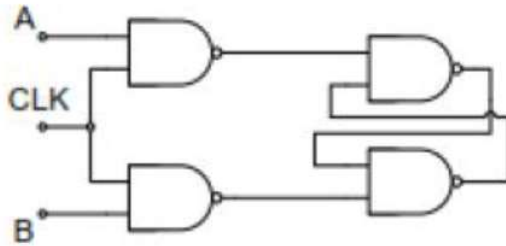

Options :

1. ✓ Does not occur
2. ✗ Occurs when $CLK=0$
3. ✗ Occurs when $CLK=1$ and $A=B=1$
4. ✗ Occurs when $CLK=1$ and $A=B=0$

Question Number : 51 Question Id : 873718171 Display Question Number : Yes Is Question Mandatory : No

Among the digital IC families ,ECL ,TTL and CMOS

Options :

1. ✓ ECL has the least propagation delay
2. ✗ TTL has largest fan out

3. ✘ CMOS has lowest noise margin

4. ✘ TTL has the lower power consumption

Question Number : 52 Question Id : 873718172 Display Question Number : Yes Is Question Mandatory : No

The basic function of TTL gate is which of the following functions?

Options :

1. ✘ AND

2. ✘ OR

3. ✘ NOR

4. ✔ NAND

Question Number : 53 Question Id : 873718173 Display Question Number : Yes Is Question Mandatory : No

Which of the following logic families dissipate minimum power

Options :

1. ✘ RTL

2. ✘ DTL

3. ✔ CMOS

4. ✘ I²L

Question Number : 54 Question Id : 873718174 Display Question Number : Yes Is Question

Mandatory : No

A microcontroller at-least should consist of:

Options :

1. ✘ RAM, ROM, I/O ports and timers
2. ✘ CPU, RAM, I/O ports and timers
3. ✔ CPU, RAM, ROM, I/O ports and timers
4. ✘ CPU, ROM, I/O ports and timers

Question Number : 55 Question Id : 873718175 Display Question Number : Yes Is Question

Mandatory : No

Which of the following are the components of a microprocessor?

Options :

1. ✘ ALU
2. ✘ Register array
3. ✘ Control unit
4. ✔ All the above

Question Number : 56 Question Id : 873718176 Display Question Number : Yes Is Question

Mandatory : No

The Fourier transform of a periodic waveform is

Options :

1. ✘ another periodic waveform
2. ✘ continuous spectrum
3. ✘ a periodic signal
4. ✔ a train of pulses

Question Number : 57 Question Id : 873718177 Display Question Number : Yes Is Question Mandatory : No

Parseval's theorem is used to find

Options :

1. ✘ energy of a signal in time domain
2. ✔ energy of a signal in frequency domain
3. ✘ output of a system for impulse input
4. ✘ output of a system for unit step input

Question Number : 58 Question Id : 873718178 Display Question Number : Yes Is Question Mandatory : No

Convolution of two voltage pulses of amplitudes 1 Volt and width 1 sec is a

Options :

1. ✘ rectangular pulse

2. ✘ square pulse
3. ✘ trapezoidal
4. ✔ triangular pulse

Question Number : 59 Question Id : 873718179 Display Question Number : Yes Is Question Mandatory : No

The power spectral density of white noise is

Options :

1. ✔ constant
2. ✘ band limited
3. ✘ impulse
4. ✘ low pass band limited

Question Number : 60 Question Id : 873718180 Display Question Number : Yes Is Question Mandatory : No

The number of AM broadcast stations that can be accommodated in a 100 KHz bandwidth for the highest modulating frequency of 5 KHz with no guard band is

Options :

1. ✘ 5
2. ✔ 10

3. ✖ 20

4. ✖ 50

Question Number : 61 Question Id : 873718181 Display Question Number : Yes Is Question Mandatory : No

In an AM signal, the peak antenna current is 13 Amp and the minimum current is 7 Amp.

The percentage modulation is

Options :

1. ✖ 20%

2. ✔ 30%

3. ✖ 50%

4. ✖ 100%

Question Number : 62 Question Id : 873718182 Display Question Number : Yes Is Question Mandatory : No

In FM system, if the depth of modulation is doubled, the output power

Options :

1. ✖ increases by a factor of 2

2. ✖ increases by a factor of 3

3. ✖ increases by a factor of 4

4. ✓ remains at unmodulated value

Question Number : 63 Question Id : 873718183 Display Question Number : Yes Is Question Mandatory : No

The main advantage of super heterodyne receiver is

Options :

1. ✗ simple circuit

2. ✗ better tracking

3. ✓ improvement in selectivity and sensitivity

4. ✗ better alignment

Question Number : 64 Question Id : 873718184 Display Question Number : Yes Is Question Mandatory : No

An increase in the modulation index leads to increase in bandwidth in case of

Options :

1. ✗ AM

2. ✓ FM

3. ✗ PM

4. ✗ PCM

Question Number : 65 Question Id : 873718185 Display Question Number : Yes Is Question

Mandatory : No

A PAM signal can be detected by

Options :

1. ✘ band pass filter

2. ✘ band stop filter

3. ✘ high pass filter

4. ✔ low pass filter

Question Number : 66 Question Id : 873718186 Display Question Number : Yes Is Question

Mandatory : No

As the sampling frequency is increased, the guard band becomes

Options :

1. ✘ smaller

2. ✘ remains same

3. ✔ larger

4. ✘ becomes narrow

Question Number : 67 Question Id : 873718187 Display Question Number : Yes Is Question

Mandatory : No

Which of the following gives maximum probability of error

Options :

1. ✓ ASK
2. ✗ FSK
3. ✗ PSK
4. ✗ DPSK

Question Number : 68 Question Id : 873718188 Display Question Number : Yes Is Question Mandatory : No

The total bandwidth required for a raised cosine spectrum is

Options :

1. ✗ $W/2$
2. ✗ W
3. ✓ $2W$
4. ✗ $4W$

Question Number : 69 Question Id : 873718189 Display Question Number : Yes Is Question Mandatory : No

At a given probability of error, binary coherent FSK is inferior to binary coherent PSK by

Options :

1. ✗ 6 dB

2. ✘ 3 dB

3. ✔ 2 dB

4. ✘ 0 dB

Question Number : 70 Question Id : 873718190 Display Question Number : Yes Is Question Mandatory : No

A PAM signal can be detected by using

Options :

1. ✘ an ADC

2. ✔ an integrator

3. ✘ a BPF

4. ✘ a HPF

Question Number : 71 Question Id : 873718191 Display Question Number : Yes Is Question Mandatory : No

The capacitive microphone is used for the detection of

Options :

1. ✘ Heart rate

2. ✘ Blood flow

3. ✓ Heart sound

4. ✗ PH electrode

Question Number : 72 Question Id : 873718192 Display Question Number : Yes Is Question Mandatory : No

Magnetic blood flow meter works on ----- principle

Options :

1. ✗ Electrical conductivity

2. ✗ Electrical resistivity

3. ✓ Faraday law of induction

4. ✗ Impedance

Question Number : 73 Question Id : 873718193 Display Question Number : Yes Is Question Mandatory : No

The normal PH of the blood is

Options :

1. ✗ 7

2. ✓ 7.4

3. ✗ 6

4. ✗ 8

Question Number : 74 Question Id : 873718194 Display Question Number : Yes Is Question Mandatory : No

_____ is the closeness with which an instrument reading approaches the true value of the variable being measured

Options :

1. ✓ Accuracy
2. ✗ Isolation
3. ✗ Linearity
4. ✗ Stability

Question Number : 75 Question Id : 873718195 Display Question Number : Yes Is Question Mandatory : No

An infrared LED is usually fabricated from

Options :

1. ✗ GA
2. ✗ Si
3. ✗ GaAs
4. ✓ Ga As P

Question Number : 76 Question Id : 873718196 Display Question Number : Yes Is Question

Mandatory : No

Parallax error is not present in

Options :

1. ✘ moving coil meter
2. ✘ FET voltmeter
3. ✘ Diode voltmeter
4. ✔ Digital voltmeter

Question Number : 77 Question Id : 873718197 Display Question Number : Yes Is Question

Mandatory : No

The best method for precise measurement of low resistance is

Options :

1. ✔ Wheatstone bridge
2. ✘ Loss of charge method
3. ✘ Ohm meter
4. ✘ Kelvin double bridge

Question Number : 78 Question Id : 873718198 Display Question Number : Yes Is Question

Mandatory : No

Which of the following optical transducers is an active transducer

Options :

1. ✘ Photo emissive cell
2. ✘ Photo diode
3. ✘ Photo transistor
4. ✔ Photo voltaic cell

Question Number : 79 Question Id : 873718199 Display Question Number : Yes Is Question Mandatory : No

A moving coil galvanometer is made into a DC ammeter by connecting

Options :

1. ✘ a low resistance across the meter
2. ✘ a high resistance in series with the meter
3. ✔ a pure inductance across the meter
4. ✘ a capacitor in series with the meter

Question Number : 80 Question Id : 873718200 Display Question Number : Yes Is Question Mandatory : No

The Triac can be used as _____

Options :

1. ✘ inverter
2. ✘ rectifier

3. ✓ multiquadrant chopper

4. ✘ cycloconverter

Question Number : 81 Question Id : 873718201 Display Question Number : Yes Is Question Mandatory : No

For the system shown in the figure, $Y(s) / X(s) = \underline{\hspace{2cm}}$.

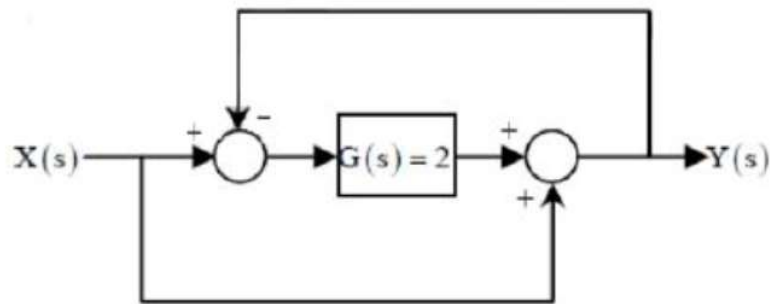

Options :

1. ✘ 1

2. ✘ 2

3. ✘ 3

4. ✓ 4

Question Number : 82 Question Id : 873718202 Display Question Number : Yes Is Question Mandatory : No

The equivalent of the block diagram in figure is given as

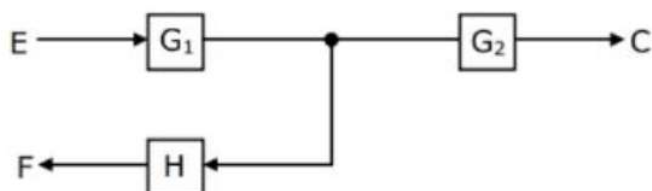

Options :

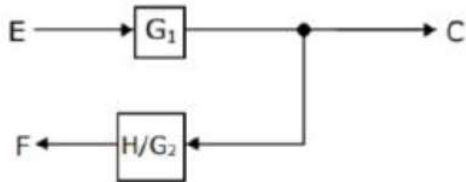

1. ✘

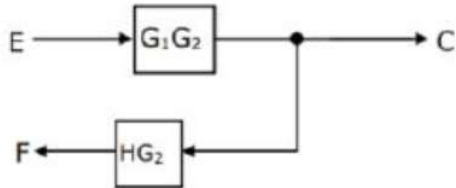

2. ✘

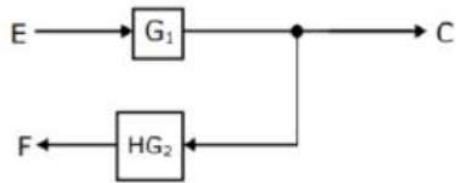

3. ✘

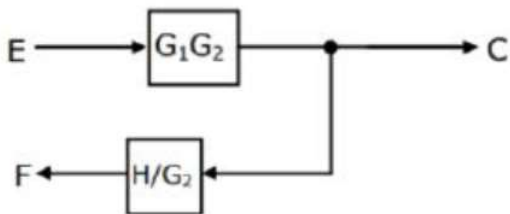

4. ✔

Question Number : 83 Question Id : 873718203 Display Question Number : Yes Is Question

Mandatory : No

For a second order system, damping ratio (ζ), is $0 < \zeta < 1$, then the roots of the characteristic polynomial are

Options :

1. ✘ Real but not equal

2. ✘ Real and equal

3. ✓ Complex conjugate

4. ✗ Imaginary

Question Number : 84 Question Id : 873718204 Display Question Number : Yes Is Question Mandatory : No

The number of roots of $s^3+5s^2+7s+3=0$ in the left half of the s-plane are

Options :

1. ✗ 0

2. ✗ 1

3. ✗ 2

4. ✓ 3

Question Number : 85 Question Id : 873718205 Display Question Number : Yes Is Question Mandatory : No

Given the $G(s)H(s)=K/s(s+1)(s+3)$, the point of intersection of the asymptotes of the root loci with the real axis is

Options :

1. ✗ -4

2. ✗ 1.33

3. ✓ -1.33

4. ✗ 4

Question Number : 86 Question Id : 873718206 Display Question Number : Yes Is Question Mandatory : No

In the Bode-plot of a unity feedback control system, the value of phase of $G(j\omega)$ at the gain cross over frequency is -125° . The phase margin of the system is

Options :

1. ✘ -125°

2. ✘ -55°

3. ✔ 55°

4. ✘ 125°

Question Number : 87 Question Id : 873718207 Display Question Number : Yes Is Question Mandatory : No

A process with open-loop model, $G(s) = \frac{K e^{-std}}{ts+1}$, is controlled by a PID controller.

For this process

Options :

1. ✘ the integral mode improves transient performance

2. ✔ the integral mode improves steady state performance

3. ✘ the derivative mode improves transient performance

4. ✘ the derivative mode improves steady state performance

Question Number : 88 Question Id : 873718208 Display Question Number : Yes Is Question Mandatory : No

The open-loop transfer function of a plant is given as $G(s)=1/s^2-1$. If the plant is operated in a unity feedback configuration, then the lead compensator that can stabilize this control system is

Options :

1. ✘ $G(s)=10(s-1)/s+2$
2. ✘ $G(s)=10(s+4)/s+2$
3. ✔ $G(s)=10(s+2)/s+10$
4. ✘ $G(s)=2(s+2)/s+10$

Question Number : 89 Question Id : 873718209 Display Question Number : Yes Is Question Mandatory : No

Let $x(t)$ be the input to a linear, time-invariant system. The required output is $4x(t-2)$. The transfer function of the system should be

Options :

1. ✘ $4e^{j4\pi f}$
2. ✘ $2e^{-j8\pi f}$
3. ✔ $4e^{-j4\pi f}$
4. ✘ $2e^{j8\pi f}$

Question Number : 90 Question Id : 873718210 Display Question Number : Yes Is Question Mandatory : No

Nyquist plot of two functions $G_1(s)$ and $G_2(s)$ are shown in figure.

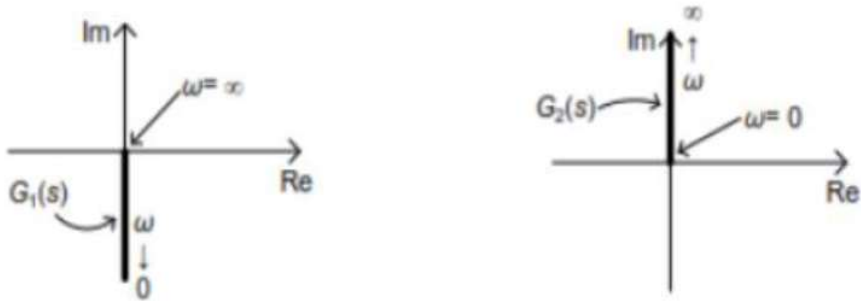

Nyquist plot of the product of $G_1(s)$ and $G_2(s)$ is

Options :

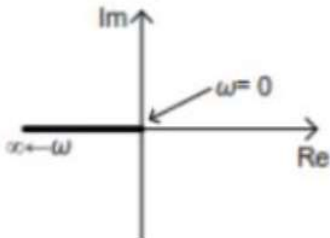

1. ✘

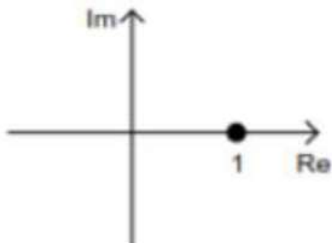

2. ✔

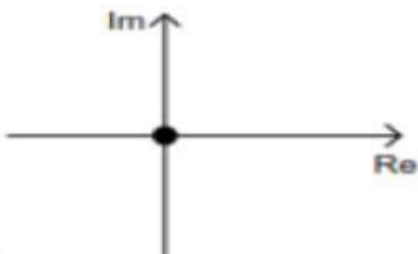

3. ✘

4. ✘

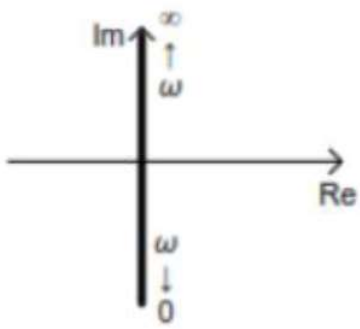

Question Number : 91 Question Id : 873718211 Display Question Number : Yes Is Question Mandatory : No

The Mass spectrum is a plot of

Options :

1. ✘ mass/charge
2. ✔ Ion abundance vs Mass/charge
3. ✘ ion abundance
4. ✘ electron motion

Question Number : 92 Question Id : 873718212 Display Question Number : Yes Is Question Mandatory : No

The unit of spectrum measured in Mass Spectrometry is

Options :

1. ✘ Coulombs/ unit charge
2. ✘ Hertz
3. ✘ Daltons

4. ✓ Daltons / unit charge

Question Number : 93 Question Id : 873718213 Display Question Number : Yes Is Question Mandatory : No

Mass spectrometer can be used to identify _____ in the expired gas

Options :

1. ✗ Oxygen
2. ✗ Nitrogen
3. ✗ Carbon di-oxide
4. ✓ Gases other than O₂, N₂, CO₂

Question Number : 94 Question Id : 873718214 Display Question Number : Yes Is Question Mandatory : No

In a spectrophotometer for each wavelength setting, the reference is set by

Options :

1. ✗ Sample itself
2. ✗ UV lights
3. ✓ Black Cuvette
4. ✗ Visible light

Question Number : 95 Question Id : 873718215 Display Question Number : Yes Is Question Mandatory : No

The absorption filters used in the spectrophotometer consists of absorption filters made up of

Options :

1. ✓ Gelatine
2. ✗ Paper
3. ✗ Wood
4. ✗ Iodine

Question Number : 96 Question Id : 873718216 Display Question Number : Yes Is Question Mandatory : No

The 2 types of wavelength selectors in spectrophotometers are

Options :

1. ✓ Glass filters and interference filters
2. ✗ Glass filters and polarization filters
3. ✗ Glass filters and prisms
4. ✗ Glass filters and LEDs

Question Number : 97 Question Id : 873718217 Display Question Number : Yes Is Question Mandatory : No

In Laser production the amount change of Energy state is a function of

Options :

1. ✖ Absolute temperature
2. ✖ Valence electrons
3. ✖ Velocity
4. ✔ Plank's constant

Question Number : 98 Question Id : 873718218 Display Question Number : Yes Is Question Mandatory : No

In an LED the holes lie in the _____ band and the electrons lie in the _____ band.

Options :

1. ✔ Valence, Conduction
2. ✖ Valence, Insulation
3. ✖ Valence, Inert
4. ✖ Conduction, Valence

Question Number : 99 Question Id : 873718219 Display Question Number : Yes Is Question Mandatory : No

A biomedical application of photodetector is

Options :

1. ✖ MRI

2. ✘ Ultrasound

3. ✔ Pulse Oximeter

4. ✘ ECG

Question Number : 100 Question Id : 873718220 Display Question Number : Yes Is Question Mandatory : No

In a fiber optic cable the refractive index of the core is _____ than that of the cladding

Options :

1. ✔ greater

2. ✘ lesser

3. ✘ almost equal

4. ✘ equal

Question Number : 101 Question Id : 873718221 Display Question Number : Yes Is Question Mandatory : No

For a multimoded graded index Fibre Optic cable the core diameters are _____ than that of the single mode fiber

Options :

1. ✔ greater

2. ✘ lesser

3. ✖ almost equal

4. ✖ equal

Question Number : 102 Question Id : 873718222 Display Question Number : Yes Is Question Mandatory : No

In photoconductivity, the gain is (consider E- No of electrons; P- No of Protons; Ph-No of photons).

Options :

1. ✖ P/E

2. ✖ E/ P

3. ✔ E/ Ph

4. ✖ Ph/ E

Question Number : 103 Question Id : 873718223 Display Question Number : Yes Is Question Mandatory : No

Which of these bio-potentials is more directly useful to analyse the conscious level of a patient in anaesthesia

Options :

1. ✖ ECG

2. ✖ EMG

3. ✔ EEG

4. ✘ PCG

Question Number : 104 Question Id : 873718224 Display Question Number : Yes Is Question Mandatory : No

Which of the EEG frequency relates to the REM sleep?

Options :

1. ✘ Alpha

2. ✘ Beta

3. ✔ Theta

4. ✘ Delta

Question Number : 105 Question Id : 873718225 Display Question Number : Yes Is Question Mandatory : No

The Electrode Montage selector in an EEG machine selects ___ out of ___ electrode signals.

Options :

1. ✔ 8 , 20

2. ✘ 1, 20

3. ✘ 2, 20

4. ✘ 16, 20

Question Number : 106 Question Id : 873718226 Display Question Number : Yes Is Question

Mandatory : No

A blood vessel that enters the heart is a _____ and that enters any other organ is _____

Options :

1. ✓ vein, artery
2. ✘ artery, vein
3. ✘ superior, inferior vena cava
4. ✘ aorta, vein

Question Number : 107 Question Id : 873718227 Display Question Number : Yes Is Question

Mandatory : No

The main pumping action of the heart is accomplished by _____ and the associated pressure is said to be _____

Options :

1. ✘ Arteries, Systolic
2. ✓ Ventricles, Systolic
3. ✘ Arteries, diastolic
4. ✘ Ventricles, diastolic

Question Number : 108 Question Id : 873718228 Display Question Number : Yes Is Question

Mandatory : No

The amplitude of ECG, EMG, EEG can be in the range of

Options :

1. ✘ mV, μ V, mV
2. ✔ mV, mV, μ V
3. ✘ μ V, mv, μ V
4. ✘ μ V, μ V, μ V

Question Number : 109 Question Id : 873718229 Display Question Number : Yes Is Question

Mandatory : No

For EMG measurements to a muscle mass and a muscle fiber _____ and _____ types of electrodes are respectively used.

Options :

1. ✘ Surface, Surface
2. ✔ Surface, Needle
3. ✘ Needle, Surface
4. ✘ Needle, Coaxial

Question Number : 110 Question Id : 873718230 Display Question Number : Yes Is Question

Mandatory : No

The prolonged QRS complex in ECG represents

Options :

1. ✘ First degree Block

2. ✓ Bundle Block

3. ✘ Fibrillation

4. ✘ Defibrillation

Question Number : 111 Question Id : 873718231 Display Question Number : Yes Is Question

Mandatory : No

Consider the linear system $x + 2y + z = 3$; $ay + 4z = 8$; $x + 7y + az = b$. The values of (a, b) for which the system has more than one solution are

Options :

1. ✘ $(4, -2), (2, 6)$

2. ✘ $(5, -11), (4, 7)$

3. ✘ $(2, 3), (3, -1)$

4. ✓ $(5, 11), (-4, -7)$

Question Number : 112 Question Id : 873718232 Display Question Number : Yes Is Question

Mandatory : No

For what values of λ the homogeneous system $(\lambda - 2)x + 4y = 0$; $4x + (\lambda - 2)y = 0$ has a nontrivial solution

Options :

1. ✘ 6, 2

2. ✘ 2, -6

3. ✓ 6,-2

4. ✗ -6,-2

Question Number : 113 Question Id : 873718233 Display Question Number : Yes Is Question Mandatory : No

$$\lim_{(x,y) \rightarrow (0,0)} \frac{-xy}{x^2+y^2}$$

Options :

1. ✓ Does not exist

2. ✗ 0

3. ✗ 0.5

4. ✗ -0.5

Question Number : 114 Question Id : 873718234 Display Question Number : Yes Is Question Mandatory : No

$$\int_0^1 \int_y^{\sqrt{y}} dx dy \text{ is equal to}$$

Options :

1. ✓ $\int_0^1 \int_{x^2}^x dy dx$

2. ✗ $\int_0^1 \int_{\sqrt{x}}^x dy dx$

3. ✗

$$\int_0^1 \int_x^{x^2} dy \, dx$$

4. ✖ $\int_0^1 \int_{\sqrt{x}}^{x^2} dy \, dx$

Question Number : 115 Question Id : 873718235 Display Question Number : Yes Is Question Mandatory : No

Solution of $e^y dx + (xe^y + 3y^2) dy = 0$ is

Options :

1. ✔ $xe^y + y^3 = C$

2. ✖ $ye^x + y^3 = C$

3. ✖ $xe^y + x^3 = C$

4. ✖ $ye^x + x^3 = C$

Question Number : 116 Question Id : 873718236 Display Question Number : Yes Is Question Mandatory : No

The boundary value problem $\frac{d^2y}{dx^2} + 25y = 0$; $\frac{dy}{dx}(0) = 6$, $\frac{dy}{dx}(\pi) = -9$

Options :

1. ✖ has exactly two solutions

2. ✖ has infinitely many solutions

3. ✖ has unique solution

4. ✓ has no solution

Question Number : 117 Question Id : 873718237 Display Question Number : Yes Is Question Mandatory : No

Ms. Perez figures that there is a 30 percent chance that her company will set up a branch office in Phoenix. If it does, she is 60 percent sure that she will made manager of this new operation. The probability that Perez will be a Phoenix branch office manager is

Options :

1. ✗ 0.25

2. ✓ 0.18

3. ✗ 0.12

4. ✗ 0.32

Question Number : 118 Question Id : 873718238 Display Question Number : Yes Is Question Mandatory : No

A binomial random variable has mean 5 and variance 4. The values of n and p that characterizes the distribution of this random variable are

Options :

1. ✗ $n = 25, p = 0.4$

2. ✗ $n = 20, p = 0.2$

3. ✓ $n = 25, p = 0.2$

4. ✖ $n = 24, p = 0.2$

Question Number : 119 Question Id : 873718239 Display Question Number : Yes Is Question Mandatory : No

$f(z) = |z|^2$ is

Options :

1. ✖ Differentiable everywhere
2. ✔ Differentiable only at $z = 0$
3. ✖ Differentiable for all z in $|z| < 1$
4. ✖ Nowhere differentiable

Question Number : 120 Question Id : 873718240 Display Question Number : Yes Is Question Mandatory : No

Let $f(x) = x - e^{-x} = 0$. Consider the initial guess $x_0 = 1$ then the value of x_1 in Newton-Raphson method to find out the root of $f(x) = 0$ is

Options :

1. ✔ 0.5379
2. ✖ 0.612
3. ✖ 0.597
4. ✖ 0.585