



Andhra Pradesh State Council of Higher Education

Notations :

- 1.Options shown in **green** color and with  icon are correct.
- 2.Options shown in **red** color and with  icon are incorrect.

Question Paper Name :	Electrical Engineering 28th Sep 2021 Shift2
Duration :	120
Total Marks :	120
Display Marks:	No
Share Answer Key With Delivery Engine :	Yes
Calculator :	None
Magnifying Glass Required? :	No
Ruler Required? :	No
Eraser Required? :	No
Scratch Pad Required? :	No
Rough Sketch/Notepad Required? :	No
Protractor Required? :	No
Show Watermark on Console? :	Yes
Highlighter :	No
Auto Save on Console? (SA type of questions will be always auto saved) :	Yes
Is this Group for Examiner? :	No

Electrical Engineering

Section Id : 5875878
Section Number : 1
Mandatory or Optional : Mandatory
Number of Questions : 120
Section Marks : 120
Enable Mark as Answered Mark for Review and Clear Response : Yes

Question Number : 1 Question Id : 587587841 Display Question Number : Yes Is Question Mandatory : No

Determine the values of R_L and R_C which causes the circuit to resonate at all frequencies

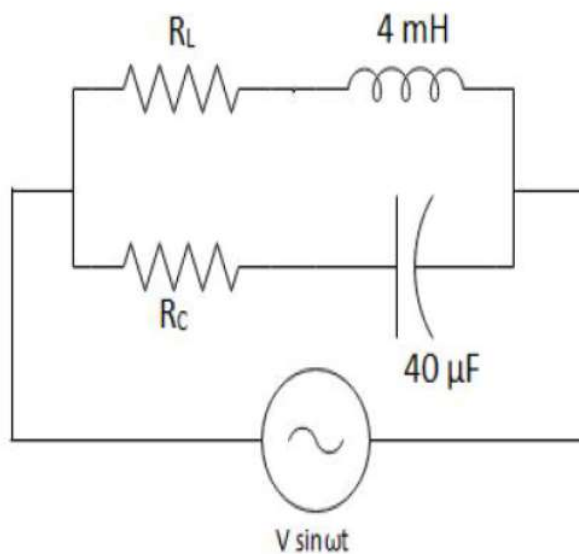

Options :

- 1. ✘ 4Ω
- 2. ✔ 10Ω
- 3. ✘ 20Ω
- 4. ✘ 40Ω

Question Number : 2 Question Id : 587587842 Display Question Number : Yes Is Question Mandatory : No

The network shown in the figure is initially under steady state condition with switch in position '1'. At $t = 0$, the switch is moved from position '1' to '2'. The current through R_1 after switching is _____.

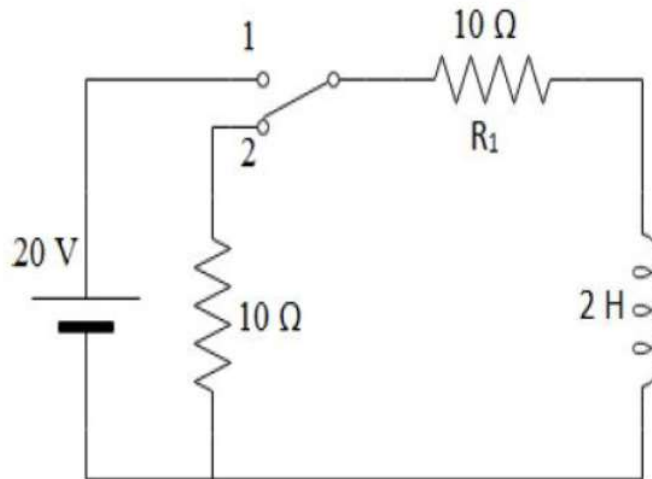

Options :

1. ✘ $10 e^{-5t}$
2. ✔ $2 e^{-10t}$
3. ✘ $10 e^{-20t}$
4. ✘ $5 e^{-2t}$

Question Number : 3 Question Id : 587587843 Display Question Number : Yes Is Question Mandatory : No

The impedance function of a parallel RLC circuit has poles located at $-3 \pm j 4$ rad/s. If the value of $L = 1$ H, the values of R and C be

Options :

1. ✘ $2 \Omega, 0.03 \mu\text{F}$

2. ✘ $3 \Omega, 0.02 \mu\text{F}$

3. ✔ $6 \Omega, 0.04 \mu\text{F}$

4. ✘ $4 \Omega, 0.03 \mu\text{F}$

Question Number : 4 Question Id : 587587844 Display Question Number : Yes Is Question

Mandatory : No

The transmission parameters of the following network are



Options :

1. ✔ $\begin{bmatrix} 1 & 2 \\ 0 & 1 \end{bmatrix}$

2. ✘ $\begin{bmatrix} 2 & 1 \\ 0 & 1 \end{bmatrix}$

3. ✘ $\begin{bmatrix} 2 & 0 \\ 0 & 1 \end{bmatrix}$

4. ✘ $\begin{bmatrix} 1 & 1 \\ 0 & 2 \end{bmatrix}$

Question Number : 5 Question Id : 587587845 Display Question Number : Yes Is Question

Mandatory : No

The number of turns of a coil having a time constant ' τ ' are quadrupled. The new time constant is

Options :

1. ✘ τ
2. ✘ $\tau/2$
3. ✘ 2τ
4. ✔ 4τ

Question Number : 6 Question Id : 587587846 Display Question Number : Yes Is Question Mandatory : No

For the circuit shown in the figure, the power is maximum in the load for the turns ratio of $n_1 : n_2 = \underline{\hspace{2cm}}$.

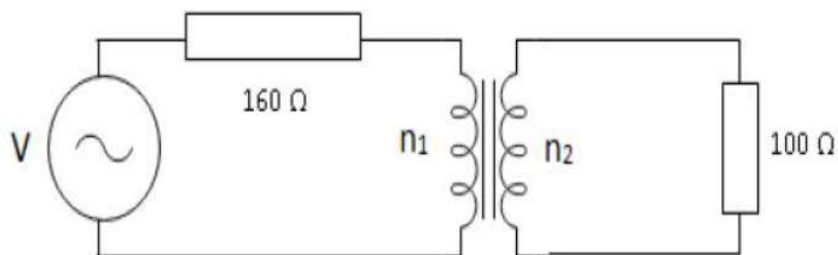

Options :

1. ✘ 16:1
2. ✔ 1:16
3. ✘ 4:1
4. ✘ 1:4

Question Number : 7 Question Id : 587587847 Display Question Number : Yes Is Question Mandatory : No

For the circuit shown below y_{21} parameter is

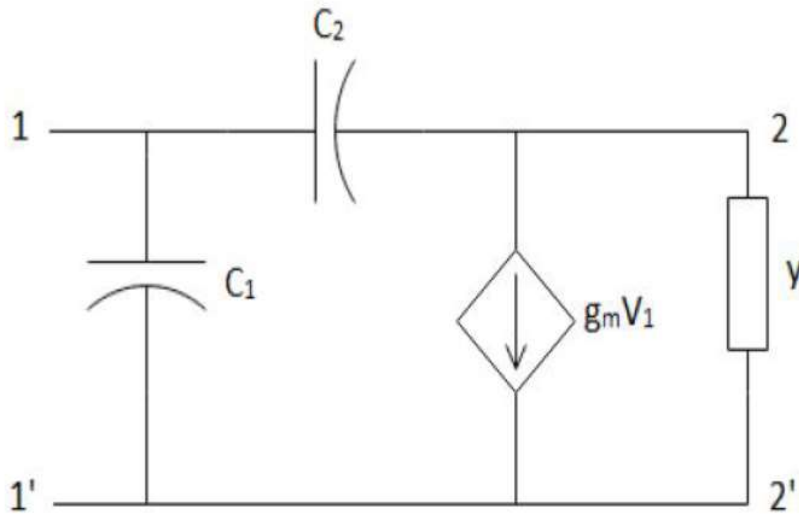

Options :

1. ✘ g_m
2. ✘ $C_2s - g_m$
3. ✔ $(C_1 + C_2)s - g_m$
4. ✘ $g_m - C_1s$

Question Number : 8 Question Id : 587587848 Display Question Number : Yes Is Question Mandatory : No

A 3- ϕ , 3 wire supply feeds a load consisting of three equal resistors connected in star. If one of the resistors is opened then percentage reduction in load is

Options :

1. ✘ 33.33
2. ✘ 66.66

3. ✘ 75

4. ✔ 50

Question Number : 9 Question Id : 587587849 Display Question Number : Yes Is Question Mandatory : No

What is the major factor for determining whether a medium is free space, lossless dielectric or lossy dielectric or good conductor?

Options :

1. ✘ Attenuation constant

2. ✘ Constitutive parameters (σ, ϵ, μ)

3. ✔ Loss tangent

4. ✘ Reflection coefficient

Question Number : 10 Question Id : 587587850 Display Question Number : Yes Is Question Mandatory : No

A parallel plate capacitor with plate area of 5 cm^2 and plate separation of 3 mm has a voltage $50 \sin 10^3 t \text{ V}$ applied to its plates. The displaced current is _____, (assume $\epsilon = 2\epsilon_0$).

Options :

1. ✘ $14.74 \sin 10^3 t \text{ nA}$

2. ✘ $1.474 \sin 10^3 t \text{ nA}$

3. ✖ $14.74 \cos 10^3 t \text{ nA}$

4. ✔ $147.4 \cos 10^3 t \text{ nA}$

Question Number : 11 Question Id : 587587851 Display Question Number : Yes Is Question Mandatory : No

Two coaxial loops of radii a and b ($b > a$) are separated by a distance of h ($h \gg a, b$) along z -axis. The mutual inductance between them is

Options :

1. ✖ $\frac{\mu \pi a b}{2 h^2}$

2. ✖ $\frac{\mu^2 \pi a b^2}{2 h^3}$

3. ✔ $\frac{\mu \pi a^2 b^2}{2 h^3}$

4. ✖ $\frac{\mu \pi a^2 b}{4 h^3}$

Question Number : 12 Question Id : 587587852 Display Question Number : Yes Is Question Mandatory : No

Planes $z = 0$ and $z = 4$ carry current $\vec{k} = -10\vec{a}_x \text{ A/m}$ and $\vec{k} = 10\vec{a}_x \text{ A/m}$ respectively.

The value of \vec{H} at $(1, 1, 1)$ is

Options :

1. ✖ $20 \vec{a}_y \text{ A/m}$

2. ✔ $10 \vec{a}_y \text{ A/m}$

3. ✖ $-10 \overline{a}_y$ A/m

4. ✖ $-20 \overline{a}_y$ A/m

Question Number : 13 Question Id : 587587853 Display Question Number : Yes Is Question Mandatory : No

A potential difference V_0 is applied to a mercury column in a cylindrical container. The mercury is now poured into another cylindrical container of half the radius and the same potential difference V_0 is applied across its ends. As a result of this change of space, the resistance will be increased

Options :

1. ✖ 2 times

2. ✖ 8 times

3. ✖ 4 times

4. ✔ 16 times

Question Number : 14 Question Id : 587587854 Display Question Number : Yes Is Question Mandatory : No

Which of the following options is true inside a very good conductor between two points a and b?

Options :

1. ✖ $E \neq 0 \quad \rho_v = 0 \quad V_{ab} = 0$

2. ✖ $E = 0 \quad \rho_v \neq 0 \quad V_{ab} = 0$

3. ✖ $E \neq 0$ $\rho_v \neq 0$ $V_{ab} = 0$

4. ✔ $E = 0$ $\rho_v = 0$ $V_{ab} = 0$

Question Number : 15 Question Id : 587587855 Display Question Number : Yes Is Question Mandatory : No

The work done by the force $F = 4\bar{a}_x - 3\bar{a}_y + 2\bar{a}_z$ N in giving 1 nC of charge a displacement of $10\bar{a}_x + 2\bar{a}_y - 7\bar{a}_z$ m is _____.

Options :

1. ✖ 60 nJ

2. ✖ 64 nJ

3. ✔ 20 nJ

4. ✖ 103 nJ

Question Number : 16 Question Id : 587587856 Display Question Number : Yes Is Question Mandatory : No

If $\vec{D} = (2y^2 + z)\bar{a}_x + 4xy\bar{a}_y + x\bar{a}_z$ C/m². The flux through the cube defined by $0 \leq x \leq 1, 0 \leq y \leq 1, 0 \leq z \leq 1$ is _____.

Options :

1. ✖ 1 C

2. ✔ 2 C

3. ✖ 4 C

8 C

4. ✖

Question Number : 17 Question Id : 587587857 Display Question Number : Yes Is Question Mandatory : No

A system $G(s) = \frac{K}{s(2+sT)}$ with unity feedback when K and T are constants. The factor by which K should be multiplied to increase the damping ratio from 0.25 to 0.75 is ___.

Options :

1. ✖ $1/3$

2. ✖ 3

3. ✔ $1/9$

4. ✖ 9

Question Number : 18 Question Id : 587587858 Display Question Number : Yes Is Question Mandatory : No

The values of K_p, K_v, K_a for Type-1 system respectively are

Options :

1. ✖ K, ∞, ∞

2. ✖ ∞, K, ∞

3. ✖ $0, K, 0$

4. ✔ $\infty, K, 0$

Question Number : 19 Question Id : 587587859 Display Question Number : Yes Is Question Mandatory : No

In root locus the angle between the adjacent asymptotes is

Options :

1. ✘ $\frac{180^\circ}{n+m}$

2. ✘ $\frac{180^\circ}{n-m}$

3. ✘ $\frac{360^\circ}{n+m}$

4. ✔ $\frac{360^\circ}{n-m}$

Question Number : 20 Question Id : 587587860 Display Question Number : Yes Is Question Mandatory : No

A system with transfer function $G(s) = \frac{s}{1+s}$ is subjected to a sinusoidal input $r(t) = \sin \omega t$. In steady state, the phase angles of the output relative to the input at $\omega = 0$ and $\omega = \infty$ will be, ___ and ___ respectively.

Options :

1. ✔ 0° and 0°

2. ✘ 0° and -90°

3. ✘ 90° and 0°

4. ✘ -90° and 0°

Question Number : 21 Question Id : 587587861 Display Question Number : Yes Is Question Mandatory : No

The transfer function of a phase lead compensator is given by

$\frac{1+asT}{1+sT}$ where $a > 1$ and $T > 0$. The maximum phase shift provided by the compensator is

Options :

1. ✘ $\tan^{-1}\left(\frac{a+1}{a-1}\right)$

2. ✘ $\cos^{-1}\left(\frac{a+1}{a-1}\right)$

3. ✔ $\sin^{-1}\left(\frac{a-1}{a+1}\right)$

4. ✘ $\cos^{-1}\left(\frac{a-1}{a+1}\right)$

Question Number : 22 Question Id : 587587862 Display Question Number : Yes Is Question Mandatory : No

The system represented by $X(t) = \begin{bmatrix} 1 & 1 \\ 2 & 0 \end{bmatrix} X(t) + \begin{bmatrix} 0 \\ 1 \end{bmatrix} u(t)$, $Y(t) = [1 \quad -1]X(t)$.

The system is

Options :

1. ✘ controllable and observable

2. ✔ controllable and not observable

3. ✖ uncontrollable and observable

4. ✖ uncontrollable and unobservable

Question Number : 23 Question Id : 587587863 Display Question Number : Yes Is Question Mandatory : No

A system described by the state equation $\begin{bmatrix} x_1' \\ x_2' \end{bmatrix} = \begin{bmatrix} 2 & 0 \\ 0 & 2 \end{bmatrix} \begin{bmatrix} x_1 \\ x_2 \end{bmatrix} + \begin{bmatrix} 1 \\ 1 \end{bmatrix} u$

The state transmission matrix of the system is

Options :

1. ✔ $\begin{bmatrix} e^{2t} & 0 \\ 0 & e^{2t} \end{bmatrix}$

2. ✖ $\begin{bmatrix} e^{-2t} & 0 \\ 0 & e^{-t} \end{bmatrix}$

3. ✖ $\begin{bmatrix} e^{2t} & 1 \\ 0 & e^{-2t} \end{bmatrix}$

4. ✖ $\begin{bmatrix} e^{-2t} & 0 \\ 0 & e^{-2t} \end{bmatrix}$

Question Number : 24 Question Id : 587587864 Display Question Number : Yes Is Question Mandatory : No

Which of the following device is very popular in switched mode power supplies?

Options :

1. ✖ BJT

2. ✓ MOSFET

3. ✗ IGBT

4. ✗ SCR

Question Number : 25 Question Id : 587587865 Display Question Number : Yes Is Question Mandatory : No

Select the correct statements with respect to IGBT

- i) lower gate drive requirement
- ii) current controlled device
- iii) lower conduction losses than MOSFET

Options :

1. ✗ i and ii

2. ✓ iii and i

3. ✗ ii and iii

4. ✗ i, ii and iii

Question Number : 26 Question Id : 587587866 Display Question Number : Yes Is Question Mandatory : No

During turn on of thyristor, spread time depends on

Options :

1. ✗ Gate current

2. ✖ Forward voltage applied
3. ✖ Steepness of gate current applied
4. ✔ Area of cathode and gate structure

Question Number : 27 Question Id : 587587867 Display Question Number : Yes Is Question Mandatory : No

Select the reason for choosing exponentially decaying gate triggering pulses for SCR firing

- i) These pulses inject large charge in gate circuit
- ii) A hard-driven SCR is obtained
- iii) Size of pulse transformer is decreased
- iv) Heat loss is less in gate circuit

Options :

1. ✖ i only
2. ✖ i and ii
3. ✔ i,ii,iii and iv
4. ✖ ii and iv

Question Number : 28 Question Id : 587587868 Display Question Number : Yes Is Question Mandatory : No

Single phase Full wave converter with source voltage V_s and source current I_s during continuous mode of operation for firing angle $\alpha = 150^\circ$, fundamental active and reactive power inputs of converter are respectively

Options :

1. ✓ $-0.866V_s * I_{s1}, 0.5V_s * I_{s1}$

2. ✗ $-0.866V_s * I_{s1}, 0.866V_s * I_{s1}$

3. ✗ $-0.5V_s * I_{s1}, 0.5V_s * I_{s1}$

4. ✗ $0.866V_s * I_{s1}, -0.5V_s * I_{s1}$

Question Number : 29 Question Id : 587587869 Display Question Number : Yes Is Question

Mandatory : No

In a three phase full wave diode bridge rectifier the ratio of average output voltage and peak inverse voltage is

Options :

1. ✗ $\pi/3$

2. ✓ $3/\pi$

3. ✗ $2/\pi$

4. ✗ $\pi/2$

Question Number : 30 Question Id : 587587870 Display Question Number : Yes Is Question

Mandatory : No

Single phase full converter feeding constant dc current into a load with firing angle α , the total harmonic distortion of converter is

Options :

1. ✓ $\sqrt{\left[\frac{\pi}{2\sqrt{2}}\right]^2 - 1}$

2. ✗ $\sqrt{\left[\frac{2\sqrt{2}}{\pi}\right]^2 - 1}$

3. ✗ $\sqrt{\left[\frac{\pi}{3\sqrt{3}} \cos\alpha\right]^2 - 1}$

4. ✗ $\sqrt{\left[\frac{3\sqrt{3}}{\pi} \cos\alpha\right]^2 - 1}$

Question Number : 31 Question Id : 587587871 Display Question Number : Yes Is Question

Mandatory : No

For a type-A chopper circuit the source voltage $V_s = 200$ V, duty ratio $\alpha = 0.5$, load parameters are $R = 1\Omega$, $E = 40$ V and L is sufficiently large so that current remains constant. The average thyristor current is ----

Options :

1. ✗ 60 A

2. ✓ 30 A

3. ✗ 120 A

4. ✗ 15 A

Question Number : 32 Question Id : 587587872 Display Question Number : Yes Is Question Mandatory : No

For eliminating fifth harmonic voltage from a chopper output voltage wave, the duty ratio of chopper should be

Options :

1. ✘ $1/3$
2. ✘ $1/9$
3. ✔ $1/5$
4. ✘ $1/25$

Question Number : 33 Question Id : 587587873 Display Question Number : Yes Is Question Mandatory : No

In case of a load commutated inverter, load components RLC must form

Options :

1. ✔ under damped circuit
2. ✘ over damped circuit
3. ✘ critically damped
4. ✘ over damped or critically damped

Question Number : 34 Question Id : 587587874 Display Question Number : Yes Is Question

Mandatory : No

Select the features of sinusoidal pulse width modulated (SPWM) inverter from the following statements

- i) amplitude modulation index ratio can vary output voltage of inverter
- ii) Higher the carrier frequency significant harmonic order decreases
- iii) modulation index ratio greater than one lower order harmonics appear in output voltage

Options :

1. ✘ i, ii and iii

2. ✘ i and ii

3. ✘ ii and iii

4. ✔ iii and i

Question Number : 35 Question Id : 587587875 Display Question Number : Yes Is Question

Mandatory : No

Single phase semi converter drives a separately excited dc motor. Armature current is constant at I_a . The rms value of freewheeling diode current is-----

Options :

1. ✘ I_a

2. ✘ $I_a/2$

3. ✔ $I_a[\alpha/\pi]^{1/2}$

4. ✘ $I_a \left[\frac{\pi - \alpha}{\pi} \right]^{1/2}$

Question Number : 36 Question Id : 587587876 Display Question Number : Yes Is Question Mandatory : No

Constant V/f control technique is used to control the speed of a three-phase induction motor.

At 50 Hz frequency, the maximum torque is 0.13. At 30 Hz frequency of operation the maximum torque is

Options :

1. ✔ 0.13

2. ✘ 0.12

3. ✘ 0.14

4. ✘ 0.065

Question Number : 37 Question Id : 587587877 Display Question Number : Yes Is Question Mandatory : No

(With usual notations) when a synchronous motor is connected through inductive impedance under steady state conditions with constant E_f , V_t and Z_s , the maximum power output is given by

Options :

1. ✔ $\frac{E_f V_t}{Z_s} - \frac{V_t^2}{Z_s^2} I_a$

2. ✘ $\frac{E_f V_t}{Z_s} - \frac{E_f^2}{Z_s^2} I_a$

3. ✘ $\frac{E_f V_t}{Z_s} + \frac{E_f^2}{Z_s^2} I_a$

4. ✘ $\frac{E_f V_t}{Z_s} + \frac{V_t^2}{Z_s^2} I_a$

Question Number : 38 Question Id : 587587878 Display Question Number : Yes Is Question Mandatory : No

Match the following:

<u>Nature of load</u>	<u>Angle between Armature m.m.f and field m.m.f</u>
(i) U.P.F	(L) 0^0
(ii) Z.P.F lag	(M) 90^0
(iii) Z.P.F lead	(N) 180^0
(iv) Lagging p.f	(O) more than 90^0

Options :

1. ✘ (i) – (N) ; (ii) – (L) ; (iii) – (M) ; (iv) - (O)

2. ✘ (i) – (N) ; (ii) – (L) ; (iii) – (O) ; (iv) - (M)

3. ✔ (i) – (M) ; (ii) – (N) ; (iii) – (L) ; (iv) - (O)

4. ✘ (i) –(N) ; (ii) – (M) ; (iii) – (O) ; (iv) - (L)

Question Number : 39 Question Id : 587587879 Display Question Number : Yes Is Question

Mandatory : No

Pitch factor of a 3-phase alternator having 36 stator slots, 4 poles and coil span of 1 to 8 is

Options :

1. ✘ $\cos 10^\circ$

2. ✔ $\cos 20^\circ$

3. ✘ $\cos 15^\circ$

4. ✘ $\cos 30^\circ$

Question Number : 40 Question Id : 587587880 Display Question Number : Yes Is Question

Mandatory : No

A cylindrical rotor synchronous generator having synchronous reactance of 1.2 p.u is running overexcited with $E_f = 1.2$ p.u., is delivering a synchronous power of 0.5 to the bus. The stiffness of coupling is

Options :

1. ✘ 0.5

2. ✘ 1

3. ✔ 0.866

4. ✘ 0

Question Number : 41 Question Id : 587587881 Display Question Number : Yes Is Question

Mandatory : No

Which of the following statement is correct with respect to 3-phase synchronous motor?

- (i) Non-Self starting motor
- (ii) At the time of starting its field winding is open circuited
- (iii) Damper winding prevents hunting
- (iv) At synchronous speed damping torque is produced

Options :

- 1. ✘ (i) and (ii)
- 2. ✘ (ii) and (iii)
- 3. ✘ (ii) and (iv)
- 4. ✔ (i) and (iii)

Question Number : 42 Question Id : 587587882 Display Question Number : Yes Is Question Mandatory : No

Which of the following are representing doubly and singly excited magnetic systems respectively

Options :

- 1. ✘ Solenoids and d.c shunt machines
- 2. ✔ Synchronous motors and reluctance motors
- 3. ✘ Tachometers and loud speakers
- 4. ✘ M.I instruments and synchronous motors

Question Number : 43 Question Id : 587587883 Display Question Number : Yes Is Question

Mandatory : No

For a two-phase servo motor which one of the following statements is not true?

Options :

1. ✘ The rotor diameter is small
2. ✔ The rotor resistance is low
3. ✘ The applied voltages are seldom balanced
4. ✘ The torque speed characteristics are linear

Question Number : 44 Question Id : 587587884 Display Question Number : Yes Is Question

Mandatory : No

A 400 V, 20 kW d.c shunt motor takes 2.5 A when running light. For an armature resistance of 0.5Ω , field resistance of $800\ \Omega$ and brush drop of 2V, the total constant losses are

Options :

1. ✘ 794 W
2. ✘ 894 W
3. ✔ 994 W
4. ✘ 800 W

Question Number : 45 Question Id : 587587885 Display Question Number : Yes Is Question

Mandatory : No

Which of the following statement is correct with respect to speed control of d.c motors?

Options :

1. ✘ Field control method facilitates speed control below base speed
2. ✘ Field control method is suitable for constant torque drives
3. ✘ Armature resistance control method is more efficient than Ward Leonard method
4. ✔ Ward Leonard method is suitable for constant power drive

Question Number : 46 Question Id : 587587886 Display Question Number : Yes Is Question Mandatory : No

The armature reaction m.m.f in a d.c machine makes

Options :

1. ✔ An angle of 90^0 with the main pole axis and triangular in shape
2. ✘ An angle of 90^0 with the main pole axis and trapezoidal in shape
3. ✘ An angle of 180^0 with the main pole axis and trapezoidal in shape
4. ✘ An angle of 10^0 with the main pole axis and triangular in shape

Question Number : 47 Question Id : 587587887 Display Question Number : Yes Is Question Mandatory : No

The average pitch of a six pole wave wound d.c armature having 16 slots with 2 coil sides per slot, each coil has single turn is

Options :

1. ✘ 6

2. ✘ 11

3. ✘ 7

4. ✔ 5

Question Number : 48 Question Id : 587587888 Display Question Number : Yes Is Question Mandatory : No

Identify the Incorrect statements from the following?

- i) A transformer can have zero voltage regulation at lagging power factor
- ii) A transformer can have zero voltage regulation at leading power factor
- iii) The resistance between primary and secondary windings of a transformer is Zero ohms.
- iv) The resistance between primary and secondary windings of a transformer is infinite ohms.

Options :

1. ✔ (i) and (iii)

2. ✘ (ii) and (iii)

3. ✘ (i) and (iv)

4. ✘ (ii) and (iv)

Question Number : 49 Question Id : 587587889 Display Question Number : Yes Is Question Mandatory : No

The core shape of a transformer is Cruciform to

Options :

1. ✘ Reduce copper material used for winding
2. ✔ Reduce core reluctance
3. ✘ Reduce core loss
4. ✘ Provide mechanical strength

Question Number : 50 Question Id : 587587890 Display Question Number : Yes Is Question Mandatory : No

To account for power system interconnections, a Y/Δ connected 3-phase transformer has a phase shift of

Options :

1. ✘ $\pm 45^{\circ}$
2. ✘ $\pm 60^{\circ}$
3. ✔ $\pm 30^{\circ}$
4. ✘ $\pm 15^{\circ}$

Question Number : 51 Question Id : 587587891 Display Question Number : Yes Is Question Mandatory : No

When a 2-winding transformer is connected as an auto transformer with transformation ratio “k”, the ratio of per unit full load losses as auto transformer to two winding transformer is

Options :

1. ✘ $\frac{1}{k}$

2. ✔ $1-k$

3. ✘ $\frac{1}{k+1}$

4. ✘ $\frac{1}{1-k}$

Question Number : 52 Question Id : 587587892 Display Question Number : Yes Is Question Mandatory : No

The torque developed in synchronous watts, if the power input to a 3-phase Induction motor is 40 kW running at a slip of 5% is _____ (by neglecting stator losses)

Options :

1. ✘ 40 kW

2. ✘ 2 kW

3. ✘ 42 kW

4. ✔ 38 kW

Question Number : 53 Question Id : 587587893 Display Question Number : Yes Is Question Mandatory : No

For a 2-value capacitor single phase Induction motor, at the time of starting the phase difference between main and auxiliary winding currents is

Options :

1. ✘ 45^0

2. ✘ 90^0

3. ✘ 30^0

4. ✔ $> 90^0$

Question Number : 54 Question Id : 587587894 Display Question Number : Yes Is Question Mandatory : No

When the supply voltage to a 3-phase squirrel cage Induction Motor (SCIM) is reduced by 20%, the maximum torque will be decreased by

Options :

1. ✘ 40%

2. ✘ 64%

3. ✔ 36%

4. ✘ 20%

Question Number : 55 Question Id : 587587895 Display Question Number : Yes Is Question Mandatory : No

A 3-phase, 4 pole, 50 Hz induction motor has a full load speed of 1440 r.p.m. The speed of rotor field with respect to rotor structure and stator structure respectively are

Options :

1. ✔ 60 and 1500 r.p.m

2. ✘ Zero and 1500 r.p.m
3. ✘ 1440 and 60 r.p.m
4. ✘ zero and 1400 r.p.m

Question Number : 56 Question Id : 587587896 Display Question Number : Yes Is Question Mandatory : No

When the load on a 3-phase Induction Motor is decreased from Full load to No- load

Options :

1. ✘ Both p.f and slip increases
2. ✔ Both p.f and slip decreases
3. ✘ p.f increases but slip decreases
4. ✘ p.f decreases but slip increases

Question Number : 57 Question Id : 587587897 Display Question Number : Yes Is Question Mandatory : No

Which of the following Instruments are used as standard and transfer instruments?

Options :

1. ✘ Moving Iron type
2. ✘ Moving Coil type

3. ✘ Induction type

4. ✔ Electrodynamometer type

Question Number : 58 Question Id : 587587898 Display Question Number : Yes Is Question Mandatory : No

Two sine waves of same magnitude and frequency are applied simultaneously to the Vertical and horizontal deflecting plates of CRO with phase difference of 150° between them. The Lissajous figure obtained is

Options :

1. ✘ Circle

2. ✘ Straight line

3. ✔ Ellipse

4. ✘ Parabola

Question Number : 59 Question Id : 587587899 Display Question Number : Yes Is Question Mandatory : No

Which of the following statements are correct with respect to M.I instruments?

- i) Repulsion type instruments are much more common than the attraction type
- ii) Attraction type instrument will usually have a more inductance than the corresponding repulsion instrument
- iii) Scale is uniform
- iv) For low voltage range, the power consumption is more

Options :

1. ✘ (i) and (ii)

2. ✔ (ii) and (iii)

3. ✘ (iii) and (iv)

4. ✘ (iv) and (i)

Question Number : 60 Question Id : 587587900 Display Question Number : Yes Is Question Mandatory : No

A circuit consisting of an unknown coil, a resistance and a variable capacitor connected in series is tuned to resonance using a Q- meter. If the frequency is $\frac{400}{2\pi}$ kHz and the resonant capacitor is set at 200 pF, then the effective inductance of the unknown coil is

Options :

1. ✔ $\frac{1}{32}$ H

2. ✘ $\frac{1}{64}$ H

3. ✘ $\frac{1}{16}$ H

4. ✘ $\frac{1}{8}$ H

Question Number : 61 Question Id : 587587901 Display Question Number : Yes Is Question Mandatory : No

In a single-phase M.I power factor meter, the controlling torque is provided by

Options :

1. ✘ Gravity control
2. ✘ Spring control
3. ✔ No control is needed
4. ✘ Stiffness of suspension

Question Number : 62 Question Id : 587587902 Display Question Number : Yes Is Question Mandatory : No

Which of the following statement is correct?

Options :

1. ✔ Owen's bridge is used for measurement of inductance in terms of capacitance
2. ✘ Hay's bridge is used for measurement of inductance for low Q- coils

Maxwell's Inductance capacitance bridge is used for measurement of inductance for high Q- coils

3. ✘

Campbell's bridge measures inductance in terms of standard mutual inductance

4. ✘

Question Number : 63 Question Id : 587587903 Display Question Number : Yes Is Question Mandatory : No

How would 16.95 V be displayed on a 10 V range of $4\frac{1}{2}$ digit Voltmeter?

Options :

1. ✘ 16.95

2. ✔ 16.950

3. ✘ 16.9500

4. ✘ 16.9

Question Number : 64 Question Id : 587587904 Display Question Number : Yes Is Question

Mandatory : No

The disc of an Energy meter makes 600 revolutions per unit of energy. When a 1kW load is connected, the disc rotates at 10.2 r.p.m. If the load is ON for 12 hours, how many units are recorded as error?

Options :

1. ✔ 0.24 (extra)

2. ✘ 0.24 (less)

3. ✘ 0.2 (extra)

4. ✘ 0.2 (less)

Question Number : 65 Question Id : 587587905 Display Question Number : Yes Is Question

Mandatory : No

Pantograph collector is used where the vehicles run at _____ speeds and _____ currents are to be collected respectively in railways

Options :

1. ✘ Low; Small
2. ✘ Low; Large
3. ✘ High; Small
4. ✔ High; Large

Question Number : 66 Question Id : 587587906 Display Question Number : Yes Is Question Mandatory : No

Which of the following factors will cause less specific energy consumption in the movement of electric train?

Options :

1. ✘ The distance between the stops is less
2. ✘ For a given scheduled speed, low values of acceleration and retardation
3. ✔ For a given scheduled speed, more values of acceleration and retardation
4. ✘ Steep gradient

Question Number : 67 Question Id : 587587907 Display Question Number : Yes Is Question Mandatory : No

Which of the following traction system service has small coasting period?

Options :

1. ✔ Urban only

2. ✘ Sub-urban only

3. ✘ Main line only

4. ✘ Sub-urban and main line

Question Number : 68 Question Id : 587587908 Display Question Number : Yes Is Question

Mandatory : No

An electric locomotive exerts a tractive effort of 4000 kg on level track at a speed of 50 km per hour. While going up an incline of 1 in 100, it has to exert a tractive effort of 8000 kg. The H. P of the d.c series motor is

Options :

1. ✘ 740

2. ✘ 1480

3. ✔ $(740) \sqrt{2}$

4. ✘ $(740) / \sqrt{2}$

Question Number : 69 Question Id : 587587909 Display Question Number : Yes Is Question

Mandatory : No

Identify the correct and incorrect statements among the following which refer to nodal impedance matrix

- (i) $1/Z_{ii}$ in per units refer to short circuit MVA rating in per units of the i^{th} node.
- (ii) Z_{ii} refers to the Thevenin's equivalent impedance seen between i^{th} node and reference node.

Options :

- 1. ✘ statement (i) is correct and (ii) is incorrect
- 2. ✘ statement (ii) is correct and (i) is incorrect
- 3. ✔ both statements (i) and (ii) are correct
- 4. ✘ both statements (i) and (ii) are incorrect

Question Number : 70 Question Id : 587587910 Display Question Number : Yes Is Question

Mandatory : No

If A, B, C, D represent ABCD constants of a Transmission line of length L, then what will be the constant A of the same type of Transmission line whose length is 3L is

Options :

- 1. ✘ $AB+BD$
- 2. ✘ A^2+BC
- 3. ✔ $A^3+2ABC+BCD$
- 4. ✘ $A^3+3ABC+BCD$

Question Number : 71 Question Id : 587587911 Display Question Number : Yes Is Question Mandatory : No

In a 3-core cable, if C_x is the capacitance measured between conductor and the sheath with other two cores connected to the sheath and C_y is the capacitance measured between the bunched conductors and the sheath with three cores shorted, then capacitance per phase is given by

Options :

1. ✘ $\frac{3}{2}C_y - \frac{C_x}{6}$

2. ✘ $\frac{3}{2}C_y + \frac{C_x}{6}$

3. ✔ $\frac{3}{2}C_x - \frac{C_y}{6}$

4. ✘ $\frac{3}{2}C_x + \frac{C_y}{6}$

Question Number : 72 Question Id : 587587912 Display Question Number : Yes Is Question Mandatory : No

Which of the following statements regarding corona are true?

1. It causes radio interference
2. It attenuates lightning surges
3. It amplifies switching surges
4. It causes power loss
5. It is more prevalent in the middle conductor of a transmission line employing a flat conductor configuration.

Select the correct answer using the codes given below:

Options :

1. ✘ 1, 3 and 5
2. ✘ 2, 3 and 4
3. ✔ 1, 2, 4 and 5
4. ✘ 2, 3, 4 and 5

Question Number : 73 Question Id : 587587913 Display Question Number : Yes Is Question Mandatory : No

In a power system with one slack bus, M generator buses and N load buses, the number of unknown system variables in case of Newton Raphson load flow method in rectangular form are

Options :

1. ✘ $M + N$
2. ✘ $M + 2N$

3. ✘ $2M + N$

4. ✔ $2M + 2N$

Question Number : 74 Question Id : 587587914 Display Question Number : Yes Is Question Mandatory : No

The reactance of a generator designated X'' is given as 0.25 per unit based on the generator nameplate rating 5kV, 100MVA. Find X'' on new base 10kV, 200MVA

Options :

1. ✘ 0.5 p.u

2. ✘ 0.25 p.u

3. ✔ 0.125 p.u

4. ✘ 0.0625 p.u

Question Number : 75 Question Id : 587587915 Display Question Number : Yes Is Question Mandatory : No

What is the zero-sequence impedance Z_0 of a 3-phase, Y/Y Transformer with Z , Z_N and Z_n as series leakage impedance, neutral to ground impedances on the primary and secondary side respectively all in per unit values.

Options :

1. ✘ $3Z_N$

2. ✘ $3(Z_N + Z_n)$

3. ✘ $Z + 3Z_N$

4. ✓ $Z + 3(Z_N + Z_n)$

Question Number : 76 Question Id : 587587916 Display Question Number : Yes Is Question Mandatory : No

Why does the rotor of an Alternator try to accelerate instead of decelerating, after a fault occurred on its terminals, for a fault current whose magnitude is much higher than the pre-fault load current supplied by the generator? Because the power fed into the system is

Options :

1. ✗ Mostly active power in nature
2. ✓ Mostly reactive power in nature
3. ✗ Active and reactive power both equal in nature
4. ✗ Neither active nor reactive power in nature

Question Number : 77 Question Id : 587587917 Display Question Number : Yes Is Question Mandatory : No

If a network consists of B branches and N nodes, then the number of independent mesh current equations would be

Options :

1. ✓ $B - (N - 1)$
2. ✗ $N - (B - 1)$

3. ✘ $B - N - 1$

4. ✘ $(B + N) - 1$

Question Number : 78 Question Id : 587587918 Display Question Number : Yes Is Question Mandatory : No

In a power system with one slack bus, M generator buses and N load buses, what is the size of the submatrix J_3 in the Jacobian matrix?

Options :

1. ✔ $N \times (N + M)$

2. ✘ $M \times (N + M)$

3. ✘ $(M + N) \times (N + M)$

4. ✘ $N \times M$

Question Number : 79 Question Id : 587587919 Display Question Number : Yes Is Question Mandatory : No

Given nodal admittance matrix for a three-bus system as
$$\begin{bmatrix} -j15 & j5 & j10 \\ j5 & -j25 & j20 \\ j10 & j20 & -j30 \end{bmatrix}$$

If the branch connected between nodes 2 and 3, having line series admittance $-j20$, is removed. What will be the new Y_{BUS} for the system?

Options :

1. ✘

$$\begin{bmatrix} -j15 & j5 & j10 \\ j5 & -j25 & 0 \\ j10 & 0 & -j30 \end{bmatrix}$$

2. ✓ $\begin{bmatrix} -j15 & j5 & j10 \\ j5 & -j5 & 0 \\ j10 & 0 & -j10 \end{bmatrix}$

3. ✗ $\begin{bmatrix} -j15 & j5 & j10 \\ j5 & -j45 & j20 \\ j10 & j20 & -j50 \end{bmatrix}$

4. ✗ $\begin{bmatrix} -j15 & j5 & j10 \\ j5 & -j45 & 0 \\ j10 & 0 & -j50 \end{bmatrix}$

Question Number : 80 Question Id : 587587920 Display Question Number : Yes Is Question Mandatory : No

Incremental fuel costs in Rs. per megawatt hour for two units in a plant are given by

$$\frac{dF_1}{dP_1} = 0.1P_1 + 20$$

$$\frac{dF_2}{dP_2} = 0.12P_2 + 18$$

The minimum and maximum acceptable loadings on unit-1 are to be 50 MW and 150 MW and that of unit-2 are 25MW and 75MW respectively. Determine the incremental fuel cost and the allocation of load between units for the minimum cost when load is 200 MW.

Options :

$$P_1 = 100\text{MW}, P_2 = 100\text{MW}$$

1. ✗

2. ✘ $P_1 = 75\text{MW}, P_2 = 125\text{MW}$

3. ✘ $P_1 = 150\text{MW}, P_2 = 50\text{MW}$

4. ✔ $P_1 = 125\text{MW}, P_2 = 75\text{MW}$

Question Number : 81 Question Id : 587587921 Display Question Number : Yes Is Question Mandatory : No

For protection of parallel feeders fed from one end the relays required are:

Options :

1. ✔ Non-directional relays at the source end and directional relays at the load end.

2. ✘ Non-directional relays at both the ends.

3. ✘ Directional relays at the source end and non-directional at the load end.

4. ✘ Directional relays at both the ends.

Question Number : 82 Question Id : 587587922 Display Question Number : Yes Is Question Mandatory : No

Match the following properties and applications of distance relays.

i. Impedance Relay

i. Voltage restrained
directional relay

i. Long length lines

ii. Reactance Relay

ii. Directional restrained
Overcurrent relay

ii. Medium length lines

iii. Mho Relay

iii. Voltage restrained
Overcurrent relay

iii. Short length lines

Options :

1. ✘ i - i - ii , ii - ii - i , iii - iii - iii

2. ✘ i - i - i , ii - iii - iii , iii - ii - ii

3. ✘ i - iii - ii , ii - ii - i , iii - i - iii

4. ✔ i - iii - ii , ii - ii - iii , iii - i - i

Question Number : 83 Question Id : 587587923 Display Question Number : Yes Is Question Mandatory : No

The rate of rise of restriking voltage depends upon:

Options :

1. ✘ The type of circuit breaker

2. ✘ The inductance of the system only

3. ✘ The capacitance of the system only

4. ✔ The resistance, inductance and capacitance of the system.

Question Number : 84 Question Id : 587587924 Display Question Number : Yes Is Question Mandatory : No

Identify the correct statements from the following, which refer to improvement of transient stability of the power system

1. by fast acting Circuit Breakers

2. by reducing line transfer reactance

3. by operating the transmission network at its fullest capacity levels

4. by line compensation techniques

Options :

1. ✘ 1, 2, 3

2. ✘ 2, 3, 4

3. ✘ 1, 3, 4

4. ✔ 1, 2, 4

Question Number : 85 Question Id : 587587925 Display Question Number : Yes Is Question Mandatory : No

Identify the correct statement which refer to Equal Area Criteria

Options :

1. ✖ it can be applicable for multi machine and single machine system stability studies.
2. ✖ it can be applicable only for multi machine stability studies.
3. ✔ it can be applicable only for single machine connected to infinite system stability studies.
4. ✖ it is independent of system size

Question Number : 86 Question Id : 587587926 Display Question Number : Yes Is Question Mandatory : No

Power in the HVDC link is varied by controlling

Options :

1. ✖ the current flowing the link
2. ✔ the voltage at both end of the link
3. ✖ DC link inductor reactance value
4. ✖ Power flow in the DC link is always constant

Question Number : 87 Question Id : 587587927 Display Question Number : Yes Is Question Mandatory : No

Identify the correct and incorrect statements in the following, which refer to Circuit Breakers (CBs).

- I. High dielectric strength, non-inflammable and low thermal conductivity type properties are required for a Gas based Circuit Breaker.
- II. Gases which can be considered for CBs are Oxygen, Hydrogen, Carbon-dioxide, Sulphur-hexafluoride and Orcton.
- III. SF6 Circuit Breaker with gas pressure above 14 kg/cm², will have heaters installed in the high pressure reservoir to avoid gas liquefaction.

Options :

1. ✘ I, II are correct, but not III
2. ✔ II, III are correct, but not I
3. ✘ I, III are correct, but not II
4. ✘ I, II, III are correct

Question Number : 88 Question Id : 587587928 Display Question Number : Yes Is Question Mandatory : No

Main purpose of FACTS devices are

1. to improve the network voltage profile through line compensation
2. to improving transient stability margin which enables to transfer power closer to transmission line rated capacity.

Options :

1. ✘ only statement 1 is correct

2. ✘ only statement 2 is correct
3. ✘ both statements 1 and 2 are incorrect
4. ✔ both statements 1 and 2 are correct.

Question Number : 89 Question Id : 587587929 Display Question Number : Yes Is Question Mandatory : No

Find the determinant of admittance matrix, if $Z_{11}=2 \Omega$, $Z_{12}=1 \Omega$, $Z_{21}=1 \Omega$, $Z_{22}=2 \Omega$

Options :

1. ✘ 5
2. ✘ 1/5
3. ✔ 1
4. ✘ 3

Question Number : 90 Question Id : 587587930 Display Question Number : Yes Is Question Mandatory : No

A $100\mu\text{A}$ ammeter has an internal resistance of 100Ω . Extending its range to measure $500\mu\text{A}$, the shunt required is of resistance (in Ω) _____

Options :

1. ✘ 20
2. ✘ 22

3. ✖ 25.00

4. ✔ 50

Question Number : 91 Question Id : 587587931 Display Question Number : Yes Is Question Mandatory : No

The time scaling property of Fourier transform for $x(at)$ is given as

(a) $\frac{1}{a} X\left(\frac{\omega}{a}\right)$ when $a > 0$

(b) $\frac{1}{|a|} X\left(\frac{\omega}{a}\right)$ when $a > 0$

(c) $\frac{1}{a} X\left(\frac{\omega}{a}\right)$ when $a < 0$

(d) $\frac{1}{|a|} X\left(\frac{\omega}{a}\right)$ when $a < 0$

Choose the correct answer from the options given below:

Options :

1. ✖ Only (A) is correct

2. ✖ Only (C) is correct

3. ✖ Both (B) and (C) are correct

4. ✔ Both (A) and (D) are correct

Question Number : 92 Question Id : 587587932 Display Question Number : Yes Is Question Mandatory : No

Which of the below mentioned statements are incorrect ?

- (A) The Fourier series of a non-periodic function consists summation of harmonics of fundamental frequency.
- (B) The Fourier series of a periodic function consist summation of harmonics of fundamental frequency.
- (C) When sinusoidal excitation is applied to a linear system, the response is also sinusoidal and has the same frequency as the excitation.
- (D) When sinusoidal excitation is applied to a linear system, the response is also sinusoidal, however, there is a change in the frequency of excitation.

Choose the correct answer from the options given below:

Options :

- 1. ✘ Both (A) and (B) are correct
- 2. ✘ Both (B) and (C) are correct
- 3. ✔ Both (A) and (D) are correct
- 4. ✘ Both (C) and (D) are correct

Question Number : 93 Question Id : 587587933 Display Question Number : Yes Is Question

Mandatory : No

Given below are two statements:

Statement I: If the sampling is done at Nyquist rate, the signal $x(t)$ can be reconstructed

from the sample values $x[n] = x[nT_s]; -\infty \leq n \leq \infty$.

Statement II: Sampling theorem forms the basis for the relation between continuous time signals.

In the light of the above statements, choose the appropriate answer from the options given below:

Options :

1. ✓ Both Statement I and Statement II are correct
2. ✗ Both Statement I and Statement II are incorrect
3. ✗ Statement I is correct but statement II is incorrect
4. ✗ Statement I is incorrect but statement II is correct

Question Number : 94 Question Id : 587587934 Display Question Number : Yes Is Question Mandatory : No

Fourier transform of function $x(t)$ exists if

Options :

1. ✗ $\int_{-T}^T x(t) dt$ exists
2. ✓ $\int_{-\infty}^{\infty} |x(t)| dt$ exists
3. ✗ $\int_{-\infty}^{\infty} |f(\omega)| dt$ exists
4. ✗ $\int_{-T/2}^{T/2} |x(t)| dt$ exists

Question Number : 95 Question Id : 587587935 Display Question Number : Yes Is Question Mandatory : No

The Laplace transform of a signal $f(t)$ is given as; $F(s) = \frac{5s+3}{s(s+1)}$. The signal will be :

Options :

1. ✘ $2u(t) + 3e^t$

2. ✘ $3u(t) - 2e^{-t}$

3. ✔ $3u(t) + 2e^{-t}$

4. ✘ $2u(t) + 3e^{-t}$

Question Number : 96 Question Id : 587587936 Display Question Number : Yes Is Question Mandatory : No

Match List I with List II

List I (Signal)	List II (Z-transform)
(a) $x[n - n_0]$	i. $X(1/z)$
(b) $x[-n]$	ii. $X(z/z_0)$
(c) $z_0^n x[n]$	iii. $X(e^{-j\omega_0} z)$
(d) $e^{j\omega n} x[n]$	iv. $z^{-n_0} X(z)$

Choose the correct answer from the options given below :

Options :

1. ✘ (a)-(ii), (b)-(iv), (c)-(i), (d)-(iii)

2. ✔ (a)-(iv), (b)-(i), (c)-(ii), (d)-(iii)

3. ✘ (a)-(ii), (b)-(iii), (c)-(iv), (d)-(i)

4. ✘ (a)-(i), (b)-(ii), (c)-(iv), (d)-(iii)

Question Number : 97 Question Id : 587587937 Display Question Number : Yes Is Question Mandatory : No

The interrupts in 8085 processor are

- (A) RST 6.5
- (B) RST 7.5
- (C) TRAP
- (D) RST 5.5

The correct sequence from the least priority to the highest priority among them is

Options :

1. ✖ (A), (C), (B), (D)

2. ✖ (D), (A), (B), (C)

3. ✔ (D), (B), (A), (C)

4. ✖ (C), (D), (B), (A)

Question Number : 98 Question Id : 587587938 Display Question Number : Yes Is Question Mandatory : No

If I is the diode current, I_0 is the saturation current, η -an empirical constant: 1 for Ge and 2 for Si, V is the diode terminal voltage, $V_T = kT/q$, k is the Boltzman's constant, T is the absolute temperature of the junction, q is the charge of electron then the Volt-Ampere equation of a p-n junction diode is given by

Options :

1. ✘ $I = I_0(e^{\frac{V_T}{\eta V}} + 1)$

2. ✘ $I = I_0(e^{\frac{\eta V}{V_T}} - 1)$

3. ✔ $I = I_0(e^{\frac{V}{\eta V_T}} - 1)$

4. ✘ $I = I_0(e^{\eta V_T/V} - 1)$

Question Number : 99 Question Id : 587587939 Display Question Number : Yes Is Question Mandatory : No

In a JFET the change in drain current is due to the applied

Options :

1. ✘ electric field between the source and the drain

2. ✔ electric field between the gate and the source

3. ✘ magnetic field between the source and the drain

4. ✘ magnetic field between the gate and the source

Question Number : 100 Question Id : 587587940 Display Question Number : Yes Is Question Mandatory : No

If the full-scale output of a 10-bit digital-to-analog converter (DAC) is 5 V then the resolution of the DAC is

Options :

1. ✓ 5 mV
2. ✘ 1 mV
3. ✘ 2.5 mV
4. ✘ 20 mV

Question Number : 101 Question Id : 587587941 Display Question Number : Yes Is Question Mandatory : No

In view of negative feedback in amplifier, which of the following features are correct?

- (A) improved signal to noise ratio at the output
- (B) increased distortion
- (C) reduced impact offset voltage
- (D) increased bandwidth

Choose the correct answer from the options given below

Options :

1. ✘ Both (A) and (B) are correct
2. ✓ Both (A) and (D) are correct
3. ✘ (A), (B) and (D) are correct
4. ✘ (A), (B), (C) and (D) are correct

Question Number : 102 Question Id : 587587942 Display Question Number : Yes Is Question Mandatory : No

How many Flip-Flops are required to build a binary counter circuit to count from 0 to 1023?

Options :

1. ✘ 1023

2. ✘ 1024

3. ✔ 10

4. ✘ 11

Question Number : 103 Question Id : 587587943 Display Question Number : Yes Is Question Mandatory : No

Among the following, the slowest analog-to-digital converter (ADC) is

Options :

1. ✘ Parallel-comparator type

2. ✘ Successive approximation type

3. ✔ Integrating type

4. ✘ Counting type

Question Number : 104 Question Id : 587587944 Display Question Number : Yes Is Question

Mandatory : No

The output V_o of the ideal operational amplifier circuit shown in the figure is

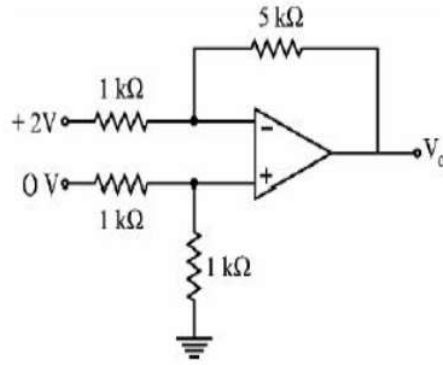

Options :

1. ✓ -10 V

2. ✗ 5 V

3. ✗ -5 V

4. ✗ 10 V

Question Number : 105 Question Id : 587587945 Display Question Number : Yes Is Question

Mandatory : No

The output of the 4-to-1 multiplexer shown in the figure is

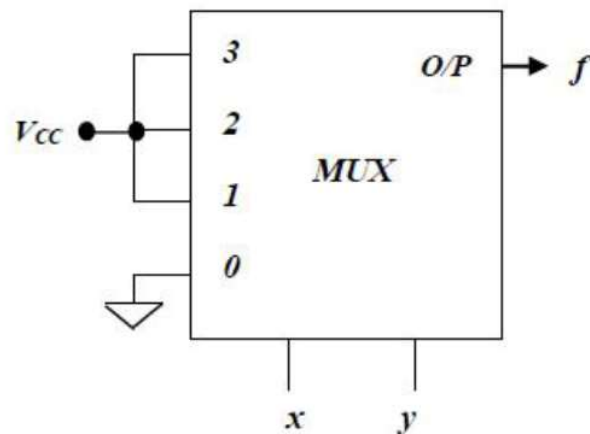

Options :

1. ✘ $x + \bar{y}$

2. ✔ $x + y$

3. ✘ $\bar{x} + \bar{y}$

4. ✘ $\bar{xy} + x$

Question Number : 106 Question Id : 587587946 Display Question Number : Yes Is Question Mandatory : No

A combinational circuit has inputs A, B and C and its K-map is as shown, the output of the circuit will be

		AB			
		00	01	11	10
C	0	0	1	0	1
	1	1	0	1	0

Options :

1. ✘ $\bar{A} + \bar{B} \bar{C}$

2. ✘ $(\bar{A}\bar{B} + AB)\bar{C}$

3. ✘ $(\bar{A}\bar{B} + A\bar{B})C$

$A \oplus B \oplus C$

4. ✔

Question Number : 107 Question Id : 587587947 Display Question Number : Yes Is Question

Mandatory : No

Match List I with List II

List I	List II
(Addressing mode)	(Instruction)
(a) Immediate addressing	(i) LDA 50 FF
(b) Implied addressing	(ii) MOV A, B
(c) Register addressing	(iii) LXI H, 2020
(d) Direct addressing	(iv) RRC

Choose the correct answer from the options given below:

Options :

1. ✘ (a)-(i), (b)-(iv), (c)-(ii), (d)-(iii)

2. ✔ (a)-(ii), (b)-(i), (c)-(iii), (d)-(iv)

3. ✘ (a)-(iii), (b)-(i), (c)-(ii), (d)-(iv)

4. ✘ (a)-(ii), (b)-(iv), (c)-(iii), (d)-(i)

Question Number : 108 Question Id : 587587948 Display Question Number : Yes Is Question

Mandatory : No

Match List I with List II

List I	List II
(a) Astable multivibrator	(i) Two stable states
(b) Bistable multivibrator	(ii) Free running
(c) Monostable multivibrator	(iii) One stable state
(d) Schmitt trigger	(iv) Square wave

Choose the correct answer from the options given below:

Options :

1. ✘ (a)-(iv), (b)-(iii), (c)-(i), (d)-(ii)

2. ✘ (a)-(iii), (b)-(iv), (c)-(i), (d)-(ii)

3. ✔ (a)-(ii), (b)-(i), (c)-(iii), (d)-(iv)

4. ✘ (a)-(ii), (b)-(i), (c)-(iv), (d)-(iii)

Question Number : 109 Question Id : 587587949 Display Question Number : Yes Is Question

Mandatory : No

In a bipolar junction transistor, α being the common base current gain, I_B being the base current and I_{C0} being the collector reverse saturation current, the collector current (I_C) is

Options :

1. ✘ $\frac{I_B}{1-\alpha} - \frac{I_{C0}}{1-\alpha}$

2. ✔ $\frac{\alpha I_B}{1-\alpha} + \frac{I_{C0}}{1-\alpha}$

3. ✘ $\frac{\alpha I_B}{1-\alpha} + I_{C0}$

4. ✘ $\frac{\alpha I_B}{1+\alpha} + \frac{I_{C0}}{1+\alpha}$

Question Number : 110 Question Id : 587587950 Display Question Number : Yes Is Question

Mandatory : No

Which of the following features of an oscillator are true?

- (A) It requires no dc supply
- (B) Phase shift around the feedback loop is zero
- (C) Gain of unity around the feedback loop
- (D) Gain lesser than unity around the feedback loop

Choose the correct one from the options given below

Options :

- 1. ✖ Both (A) and (D) are true
- 2. ✖ Both (B) and (D) are true
- 3. ✔ Both (B) and (C) are true
- 4. ✖ Only (A), (B) and (C) are true

Question Number : 111 Question Id : 587587951 Display Question Number : Yes Is Question

Mandatory : No

Let $A = \begin{bmatrix} 1 & 1 \\ -2 & 4 \end{bmatrix}$. The eigenvalues of $A^{-4} = (A^{-1})^4$ are

Options :

- 1. ✔ 1/16, 1/81
- 2. ✖ 16, 81
- 3. ✖ 8, 16

4. ✖ $1/16, 1/8$

Question Number : 112 Question Id : 587587952 Display Question Number : Yes Is Question Mandatory : No

The function $f(x, y) = 2 + 2x + 2y - x^2 - y^2$ has absolute maximum on the line

$y = 9 - x; x \in [0, 9]$ at

Options :

1. ✖ $(9, 0)$

2. ✔ $(\frac{9}{2}, \frac{9}{2})$

3. ✖ $(0, 9)$

4. ✖ $(0, 0)$

Question Number : 113 Question Id : 587587953 Display Question Number : Yes Is Question Mandatory : No

Outward flux of $F = \sin(\pi x) i + zy^3 j + (z^2 + 4x) k$ across the boundary of the cube defined by $-1 \leq x \leq 2, 0 \leq y \leq 1, 1 \leq z \leq 4$ is

Options :

1. ✖ $135/4$

2. ✖ 135

3. ✓ $135/2$

4. ✗ $135/8$

Question Number : 114 Question Id : 587587954 Display Question Number : Yes Is Question Mandatory : No

$\int_0^1 \int_{x^3}^{\sqrt{x}} f(x, y) dy dx$ is equal to

Options :

1. ✓ $\int_0^1 \int_{y^2}^{y^{1/3}} f(x, y) dx dy$

2. ✗ $\int_0^1 \int_{y^{1/3}}^{y^2} f(x, y) dx dy$

3. ✗ $\int_0^1 \int_{\sqrt{y}}^{y^{1/3}} f(x, y) dx dy$

4. ✗ $\int_0^1 \int_y^{y^2} f(x, y) dx dy$

Question Number : 115 Question Id : 587587955 Display Question Number : Yes Is Question Mandatory : No

Solution of the initial value problem $2x^2 \frac{d^2y}{dx^2} + 3x \frac{dy}{dx} - 15y = 0; y(1) = 0, \frac{dy}{dx}(1) = 1$ is

Options :

1. ✓ $\frac{-2}{11}x^{-3} + \frac{2}{11}x^{5/2}$

2. ✗ $x^3 + \frac{2}{11}x^{-5/2}$

3. ✖ $x^3 + x^{-5/2}$

4. ✖ $\frac{2}{11}x^{-3} + x^{5/2}$

Question Number : 116 Question Id : 587587956 Display Question Number : Yes Is Question Mandatory : No

Which of the following partial differential equation is parabolic

Options :

1. ✖ $u_{xx} + u_{yy} = f(x, y)$

2. ✖ $u_{tt} = u_{xx}$

3. ✖ $u_{xx} + u_{yy} = 0$

4. ✔ $u_t = u_{xx} + u_{yy}$

Question Number : 117 Question Id : 587587957 Display Question Number : Yes Is Question Mandatory : No

Let the probability density for X be given by $f(x) = Ce^{-x}; x = 1, 2, 3, \dots$

The value of C that makes $f(x)$ a density is

Options :

1. ✖

$$\frac{1}{e-1}$$

2. ✓ $e - 1$

3. ✗ $\frac{1}{e}$

4. ✗ e

Question Number : 118 Question Id : 587587958 Display Question Number : Yes Is Question Mandatory : No

Let X be normal with $\mu = 5$ and $\sigma = 0.2$.

The value of K such that $P[5 - K \leq X \leq 5 + K] = 0.90$ is (use $\phi(1.645) = 0.95$ from the cumulative distribution table for standard normal variable)

Options :

1. ✗ 5.29

2. ✗ 3.29

3. ✓ 0.329

4. ✗ 0.529

Question Number : 119 Question Id : 587587959 Display Question Number : Yes Is Question Mandatory : No

Let $f(z) = \frac{5z-2}{z(z-1)}$ and $C: |z| = 2$. The value of $\int_C f(z) dz$ is

Options :

1. ✘ 0

2. ✘ πi

3. ✘ $-\pi i$

4. ✔ $10\pi i$

Question Number : 120 Question Id : 587587960 Display Question Number : Yes Is Question

Mandatory : No

Consider $\frac{dy}{dx} = 3x^2 + 1$; $y(0) = 0$. The value of $y(0.2)$ using Euler's method with step size $h = 0.1$ is

Options :

1. ✔ 0.203

2. ✘ 0.223

3. ✘ 0.198

4. ✘ 0.225