

Q1) A pneumatic nozzle-flapper system is conventionally used to convert \_\_\_\_\_

- (A) Small changes in flapper's velocity to large changes in output temperature
- (B) Small changes in flapper's displacement to large changes in output temperature
- (C) Small changes in flapper's velocity to large changes in output pressure
- (D) Small changes in flapper's displacement to large changes in output pressure

Q2) The output of a system  $y(t)$  is related to its input  $x(t)$  according to the relation  $y(t) = x(t) \sin(2\pi t)$ . This system is \_\_\_\_\_

- (A) Linear and time-variant
- (B) Non-linear and time-invariant
- (C) Linear and time-invariant
- (D) Non-linear and time-variant

Q3) A unity-gain negative-feedback control system has a loop-gain  $L(s)$  given by

$$L(s) = \frac{6}{s(s-5)}$$

The closed-loop system is \_\_\_\_\_

- (A) Causal and stable
- (B) Causal and unstable
- (C) Non-causal and stable
- (D) Non-causal and unstable

Q4) A Hall sensor is based on the principle of \_\_\_\_\_

- (A) Photoelectric effect
- (B) Seebeck effect
- (C) Piezoelectric effect
- (D) Lorentz force

Q5) A signal  $x(t)$  is band-limited between 100 Hz and 200 Hz.

A signal  $y(t)$  is related to  $x(t)$  as follows:

$$y(t) = x(2t - 5)$$

The statement that is always true is \_\_\_\_\_

- (A)  $y(t)$  is band-limited between 50 Hz and 100 Hz
- (B)  $y(t)$  is band-limited between 100 Hz and 200 Hz
- (C)  $y(t)$  is band-limited between 200 Hz and 400 Hz
- (D)  $y(t)$  is not band-limited

Q6) The figure shows a Chromel-Alumel thermocouple, where the junction A is held at

temperature  $T_A$ , and a thermal emf  $E_1$  is measured using an ideal voltmeter between the open ends B1 and B2, both held at temperature  $T_B$ . Two identical copper wires are introduced between B1-C1 and B2-C2 as shown in the figure. When C1 and C2 are held at temperature  $T_C$ , the voltmeter reads a thermal emf  $E_2$ . Then, \_\_\_\_\_

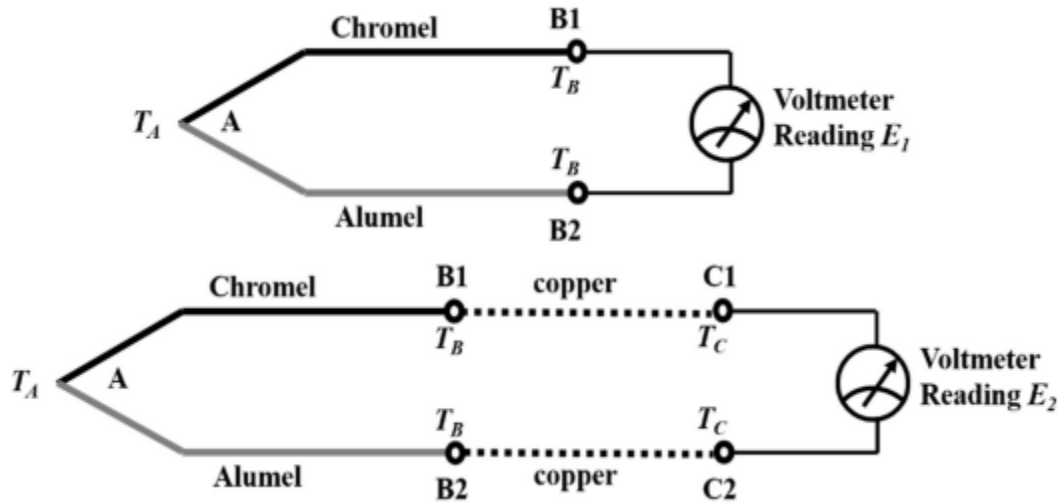

- (A)  $E_1 < E_2$
- (B)  $E_1 > E_2$
- (C)  $E_1 = 2E_2$
- (D)  $E_1 = E_2$

Q7) The resistance of a pure copper wire of length 10 cm and diameter 1 mm is to be measured. The most suitable method from amongst the choices given below is \_\_\_\_\_

- (A) Two wire method
- (B) Three wire method
- (C) Four wire method
- (D) Ellipsometry

Q8) In which of the following bridge(s) is the balancing condition frequency-independent?

- (A) Maxwell bridge
- (B) Wien bridge
- (C) Schering bridge
- (D) Wheatstone bridge

Q9) An analog-to-digital converter with resolution 0.01 V converts analog signals between 0 V to +10 V to an unsigned binary output. The minimum number of bits (in integer) in the output is \_\_\_\_\_

Q10) Consider 24 voice signals being transmitted without latency using time-division multiplexing. If each signal is sampled at 12 kHz and represented by an 8-bit word, the bit-duration (in microseconds) is \_\_\_\_\_ (round off to two decimal places)

Q11) A 440 V, 8 kW, 4-pole, 50 Hz, star-connected induction motor has a full load slip of 0.04. The rotor speed (in rpm) at full load is \_\_\_\_\_ (round off to one decimal place)

Q12) A Zener diode is used as a 4 V voltage regulator in the circuit shown. Given that the diode requires a minimum current of 4 mA for voltage regulation, the maximum current (in milliamperes) permitted to flow through the load  $R_L$  is \_\_\_\_\_ (round off to one decimal place)

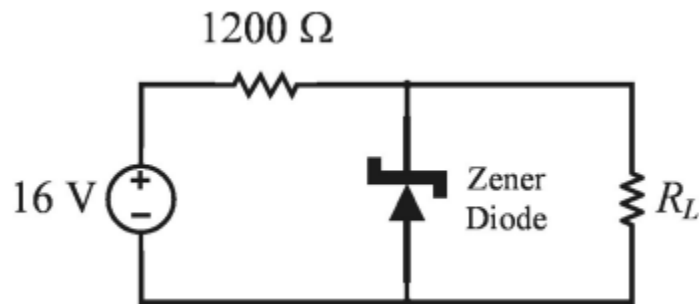

Q13) The Newton-Raphson method is applied to determine the solution of  $f(x) = 0$  where  $f(x) = x - \cos(x)$ . If the initial guess of the solution is  $x_0 = 0$ , the value of the next approximation  $x_1$  is \_\_\_\_\_ (round off to two decimal places)

Q14) A car is moving collinearly with a laser beam emitted by a transceiver. A laser pulse emitted at  $t = 0$  s is received back by the transceiver 100 ns (nanoseconds) later after reflection from the car. A second pulse emitted at  $t = 0.1$  s is received back 90 ns later. Given the speed of light is  $3 \times 10^8$  m/s, the average speed of the car in this interval is \_\_\_\_\_

- (A) 54 kmph, moving towards the transceiver
- (B) 108 kmph, moving towards the transceiver
- (C) 54 kmph, moving away from the transceiver
- (D) 108 kmph, moving away from the transceiver

Q15) The digital circuit shown \_\_\_\_\_

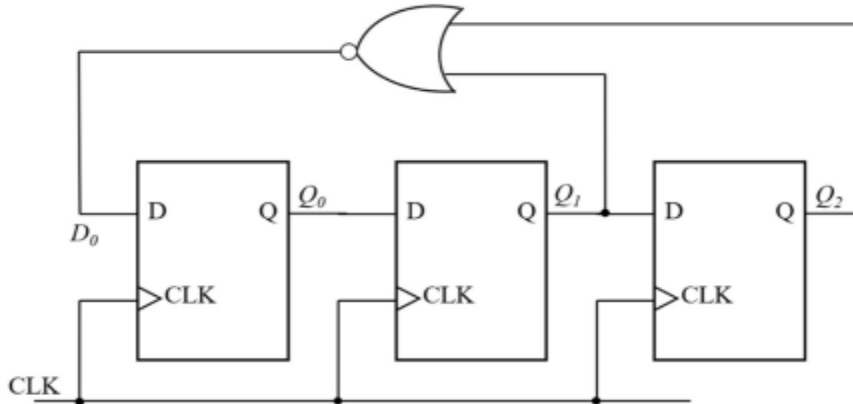

- (A) is a divide-by-5 counter
- (B) is a divide-by-7 counter
- (C) is a divide-by-8 counter
- (D) does not function as a counter due to disjoint cycles of states

Q16) Inductance of a coil is measured as 10 mH, using an LCR meter, when no other objects are present near the coil. The LCR meter uses a sinusoidal excitation at 10 kHz. If a pure copper sheet is brought near the coil, the same LCR meter will read \_\_\_\_\_.

- (A) less than 10 mH
- (B) 10 mH
- (C) more than 10 mH
- (D) less than 10 mH initially and then stabilizes to more than 10 mH

Q17) Which of the following flow meters offers the lowest resistance to the flow?

- (A) Turbine flow meter
- (B) Orifice flow meter
- (C) Venturi meter
- (D) Electromagnetic flow meter

Q18) The table shows the present state  $Q(t)$ , next state  $Q(t+1)$ , and the control input in a flip-flop. Identify the flip-flop.

$Q(t)$	$Q(t+1)$	Input
0	0	0
0	1	1

1	0	1
1	1	0

- (A) T flip-flop
- (B) D flip-flop
- (C) SR flip-flop
- (D) JK flip-flop

Q19) A light emitting diode (LED) emits light when it is \_\_\_\_\_ biased. A photodiode provides maximum sensitivity to light when it is \_\_\_\_\_ biased.

- (A) forward, forward
- (B) forward, reverse
- (C) reverse, reverse
- (D) reverse, forward

Q20) Choose the fastest logic family among the following:

- (A) Transistor-Transistor Logic
- (B) Emitter-Coupled Logic
- (C) CMOS Logic
- (D) Resistor-Transistor Logic

Q21) When the bridge given below is balanced, the current through the resistor  $R_a$  is \_\_\_\_\_ mA (rounded off to two decimal places)

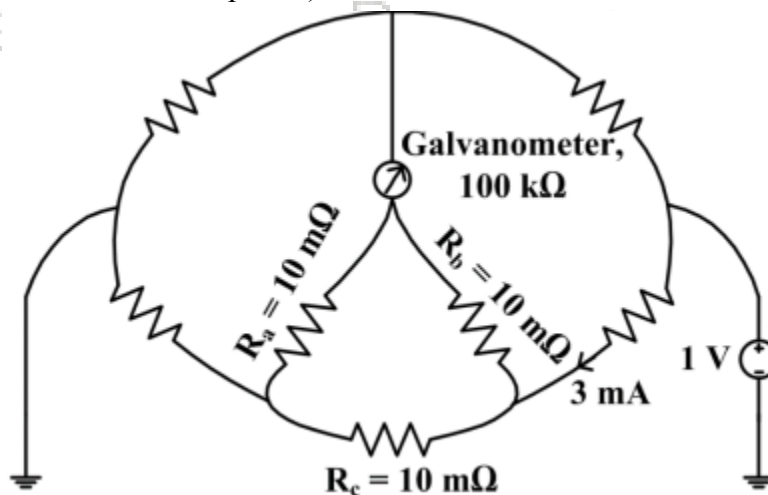

Q22) In the circuit given, the Thevenin equivalent resistance  $R_{th}$  across the terminals 'a' and 'b' is \_\_\_\_\_  $\Omega$  (rounded off to one decimal place).

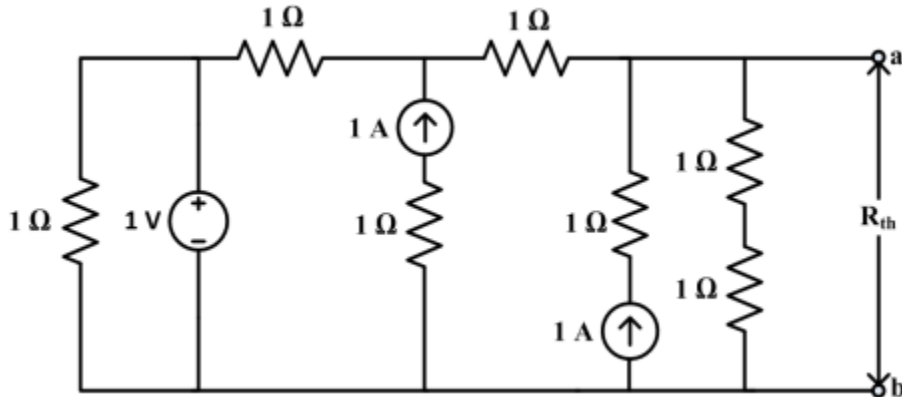

Q23) The diode in the circuit is ideal. The current source  $i_s(t) = \pi \sin(3000\pi t)$  mA. The magnitude of the average current flowing through the resistor R is \_\_\_\_\_ mA (rounded off to two decimal places).

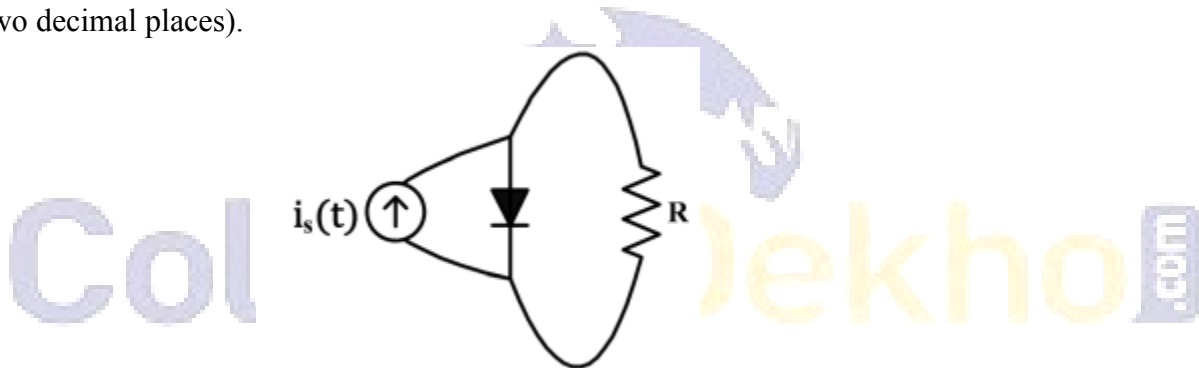

Q24) The full-scale range of the wattmeter shown in the circuit is 100 W. The turns ratio of the individual transformers are indicated in the figure. The RMS value of the ac source voltage  $V_s$  is 200 V. The wattmeter reading will be \_\_\_\_\_ W (rounded off to the nearest integer).

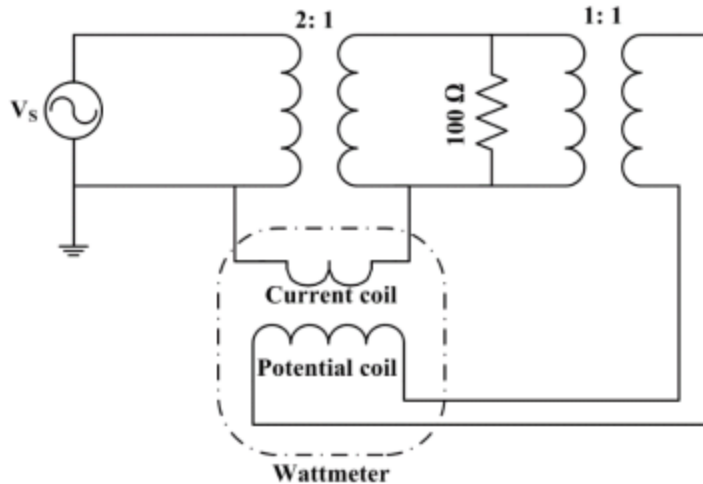

Q25) The no-load steady-state output voltage of a DC shunt generator is 200 V when it is driven in the clockwise direction at its rated speed. If the same machine is driven at the rated speed but in the opposite direction, the steady-state output voltage will be \_\_\_\_\_ V (rounded off to the nearest integer)

Q26) For the given digital circuit,  $A = B = 1$ . Assume that AND, OR, and NOT gates have propagation delays of 10 ns, 10 ns, and 5 ns respectively. All lines have zero propagation delay. Given that  $C = 1$  when the circuit is turned on, the frequency of steady-state oscillation of the output Y is \_\_\_\_\_.

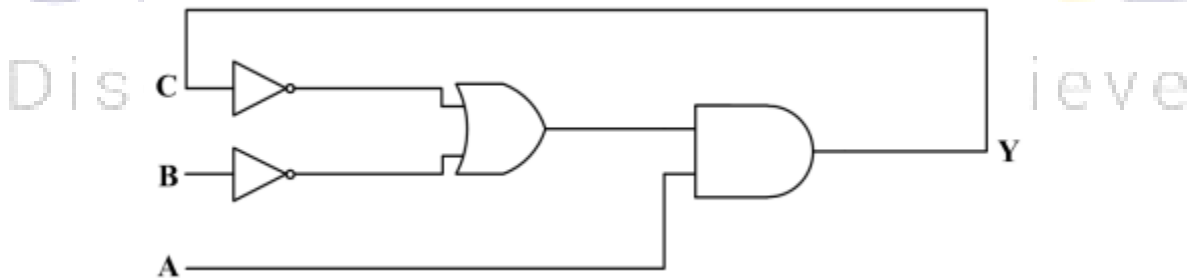

- (A) 20 MHz
- (B) 15 MHz
- (C) 40 MHz
- (D) 50 MHz

Q27) In the circuit shown, the initial binary content of shift register A is 1101 and that of shift register B is 1010. The shift registers are positive-edge triggered, and the gates have no delay.

When the shift control is high, what will be the binary content of the shift registers A and B after four clock pulses?

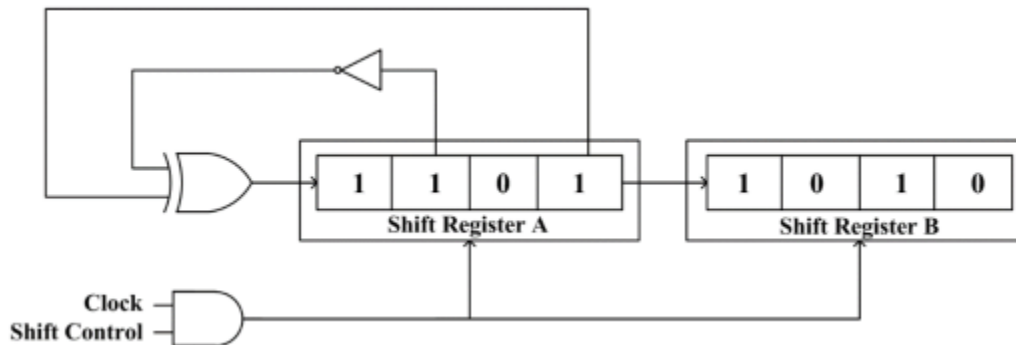

- (A) A = 1101, B = 1101
- (B) A = 1110, B = 1001
- (C) A = 0101, B = 1101
- (D) A = 1010, B = 1111

Q28) A silica-glass fiber has a core refractive index of 1.47 and a cladding refractive index of 1.44. If the cladding is completely stripped out and the core is dipped in water having a refractive index of 1.33, the numerical aperture of the modified fiber is \_\_\_\_\_ (rounded off to three decimal places)

Q29) Five measurements are made using a weighing machine, and the readings are 80 kg, 79 kg, 81 kg, 79 kg and 81 kg. The sample standard deviation of the measurement is \_\_\_\_\_ kg (rounded off to two decimal places).

Q30) Four strain gauges  $R_A$ ,  $R_B$ ,  $R_C$  and  $R_D$ , each with nominal resistance  $R$ , are connected in a bridge configuration. When a force is applied,  $R_A$  and  $R_D$  increase by  $\Delta R$  and  $R_B$  and  $R_C$  decrease by  $\Delta R$  as shown. A potentiometer with total resistance  $R_v$  is connected as shown. If  $R = 100 \Omega$ , and  $\Delta R = 1 \Omega$ , the minimum value of resistance  $R_v$  required to balance the bridge is \_\_\_\_\_  $\Omega$  (rounded off to two decimal places)



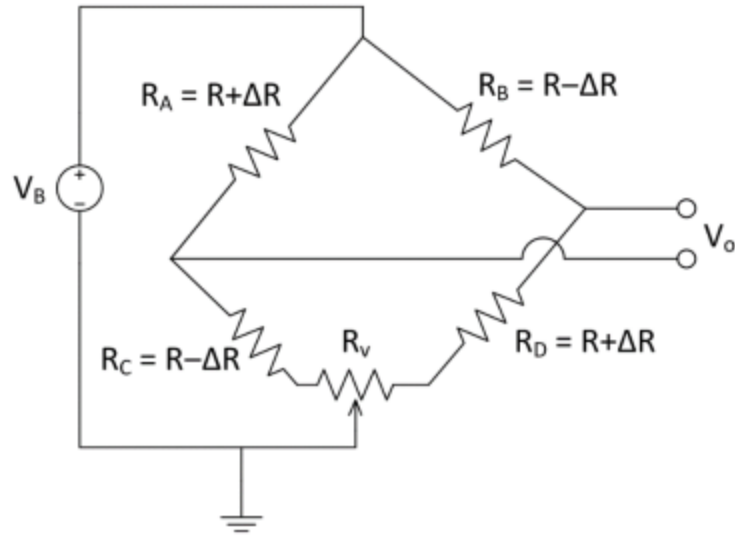

  
**CollegeDekho**.com  
Discover · Prepare · Achieve

