

Andhra Pradesh State Council of Higher Education

Notations :

- 1.Options shown in green color and with ✓ icon are correct.
- 2.Options shown in red color and with ✘ icon are incorrect.

Question Paper Name :	Instrumentation Engineering 30th May 2023 Shift 1
Duration :	120
Total Marks :	120
Display Marks:	No
Share Answer Key With Delivery Engine :	Yes
Calculator :	None
Magnifying Glass Required? :	No
Ruler Required? :	No
Eraser Required? :	No
Scratch Pad Required? :	No
Rough Sketch/Notepad Required? :	No
Protractor Required? :	No
Show Watermark on Console? :	Yes
Highlighter :	No
Auto Save on Console?	Yes
Change Font Color :	No
Change Background Color :	No
Change Theme :	No
Help Button :	No
Show Reports :	No

Show Progress Bar :	No
Is this Group for Examiner? :	No
Examiner permission :	Cant View
Show Progress Bar? :	No

Instrumentation Engineering

Section Id :	78773226
Section Number :	1
Mandatory or Optional :	Mandatory
Number of Questions :	120
Section Marks :	120
Enable Mark as Answered Mark for Review and Clear Response :	Yes
Maximum Instruction Time :	0
Is Section Default? :	null

Question Number : 1 Question Id : 7877323001 Display Question Number : Yes Is Question Mandatory : No Calculator : None Response Time : N.A Think Time : N.A Minimum Instruction Time : 0

A short in any type of circuit (series, parallel or combination) cause the total circuit

1. Resistance to decrease
2. Power to decrease
3. Current to increase
4. Voltage to increase

Which of the above are correct?

Options :

1. ✘ 2 and 3

2. ✘ 2 and 4

3. ✘ 1 and 4

4. ✔ 1 and 3

Question Number : 2 Question Id : 7877323002 Display Question Number : Yes Is Question Mandatory : No Calculator : None Response Time : N.A Think Time : N.A Minimum Instruction Time : 0

If an ideal voltage source and ideal current source are connected in series, the combination

Options :

1. ✔ has the same properties as a current source alone

2. ✘ has the same properties as a voltage source alone

3. ✘ has the same properties as the source which has a higher value

4. ✘ result in the branch being redundant

Question Number : 3 Question Id : 7877323003 Display Question Number : Yes Is Question Mandatory : No Calculator : None Response Time : N.A Think Time : N.A Minimum Instruction Time : 0

The number of independent KVL and KCL equation for a network with n -nodes and l -links are respectively

Options :

1. ✘ 1 and n

2. ✓ 1 and n-1

3. ✗ n-1 and 1

4. ✗ n-1 and l-1

Question Number : 4 Question Id : 7877323004 Display Question Number : Yes Is Question Mandatory : No Calculator : None Response Time : N.A Think Time : N.A Minimum Instruction Time : 0

While determining Thevenin resistance (R_{th}) of a circuit

Options :

1. ✗ Voltage and current source should be left as they are

2. ✓ All source should be replaced by their source resistance

3. ✗ All independent current and voltage source are short circuited

4. ✗ No current source should be replaced by their source resistance

Question Number : 5 Question Id : 7877323005 Display Question Number : Yes Is Question Mandatory : No Calculator : None Response Time : N.A Think Time : N.A Minimum Instruction Time : 0

Which of the following theorem can be applied to any network linear or nonlinear, active or passive, time -variant or time invariant?

Options :

1. ✘ Thevenin theorem
2. ✘ Norton theorem
3. ✔ Tellegen theorem
4. ✘ Superposition theorem

Question Number : 6 Question Id : 7877323006 Display Question Number : Yes Is Question Mandatory : No Calculator : None Response Time : N.A Think Time : N.A Minimum Instruction Time : 0

In two-port network, what is the other name for the Z -parameter?

Options :

1. ✘ Short circuit admittance parameter
2. ✔ Open circuit impedance parameter
3. ✘ Open circuit admittance parameter
4. ✘ Short circuit impedance parameter

Question Number : 7 Question Id : 7877323007 Display Question Number : Yes Is Question

Mandatory : No Calculator : None Response Time : N.A Think Time : N.A Minimum Instruction Time : 0

ABCD parameters are used in analysis of

Options :

1. ✘ Short circuit
2. ✘ Electronics
3. ✘ Open circuit
4. ✔ Transmission line

Question Number : 8 Question Id : 7877323008 Display Question Number : Yes Is Question Mandatory : No Calculator : None Response Time : N.A Think Time : N.A Minimum Instruction Time : 0

Which one of the following contains lesser number of nodes than the original graph?

Options :

1. ✔ Proper subgraph
2. ✘ Improper subgraph
3. ✘ Planar graph
4. ✘ Non-planar graph

Question Number : 9 Question Id : 7877323009 Display Question Number : Yes Is Question Mandatory : No Calculator : None Response Time : N.A Think Time : N.A Minimum Instruction Time : 0

What are the values of R_1 , R_2 and R_3 respectively, after transforming the Wye network shown in the figure to a delta network?

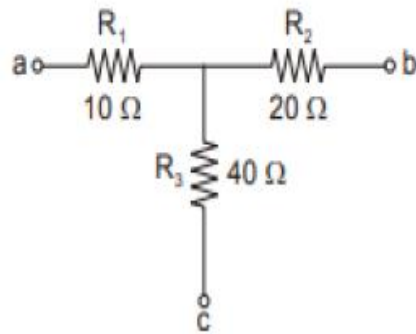

Options :

1. ✘ 140 Ω , 70 Ω and 45 Ω
2. ✘ 70 Ω , 140 Ω and 35 Ω
3. ✔ 140 Ω , 70 Ω and 35 Ω
4. ✘ 40 Ω , 70 Ω and 25 Ω

Question Number : 10 Question Id : 7877323010 Display Question Number : Yes Is Question Mandatory : No Calculator : None Response Time : N.A Think Time : N.A Minimum Instruction Time : 0

Consider the following statements regarding duality:

1. The dual networks are obtained for both AC and DC circuits and they are based on Kirchhoff's laws.
2. Dual circuits are not obtained in planar networks.
3. Two networks are said to be dual networks if mesh equations of one network have the same form as the nodal equations of the other.

Which of the above statements are correct?

Options :

1. ✘ 1 and 2 only
2. ✔ 1 and 3 only
3. ✘ 2 and 3 only
4. ✘ 1, 2 and 3

Question Number : 11 Question Id : 7877323011 Display Question Number : Yes Is Question Mandatory : No Calculator : None Response Time : N.A Think Time : N.A Minimum Instruction Time : 0

The poles and zeros of the given circuit are

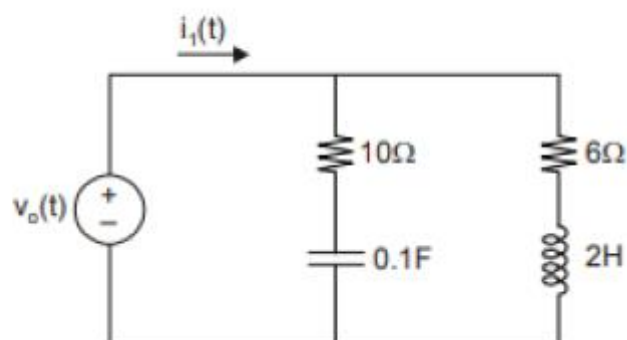

Options :

1. ✓ poles : -0.683 and -7.317 zeros : -1 and -3
2. ✘ poles : -0.483 and -5.317 zeros : -3 and -4
3. ✘ poles : -0.383 and -4.317 zeros : -2 and -3
4. ✘ poles : -0.583 and -6.317 zeros : -1 and -4

Question Number : 12 Question Id : 7877323012 Display Question Number : Yes Is Question Mandatory : No Calculator : None Response Time : N.A Think Time : N.A Minimum Instruction Time : 0

Which one of the following functions has all the poles on the $j\omega$ -axis?

Options :

1. ✓ L-C function
2. ✘ R-L function
3. ✘ R-C function
4. ✘ Y function

Question Number : 13 Question Id : 7877323013 Display Question Number : Yes Is Question Mandatory : No Calculator : None Response Time : N.A Think Time : N.A Minimum Instruction Time : 0

Which one of the following theorems becomes important if the circuit has sources operating at different frequencies?

Options :

1. ✘ Norton theorem
2. ✘ Thevenin theorem
3. ✔ Superposition theorem
4. ✘ Maximum power transfer theorem

Question Number : 14 Question Id : 7877323014 Display Question Number : Yes Is Question Mandatory : No Calculator : None Response Time : N.A Think Time : N.A Minimum Instruction Time : 0

The number of links in the graph shown in the figure is

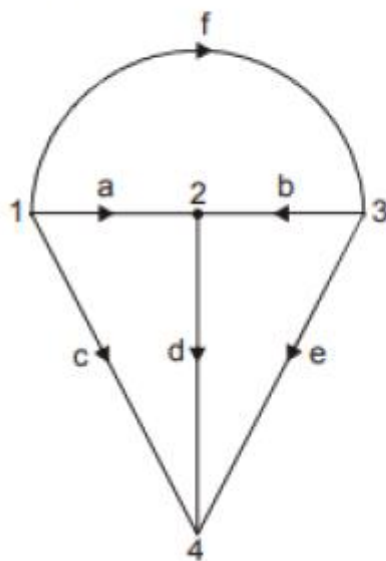

Options :

1. ✔ 3

2. ✘ 4

3. ✘ 2

4. ✘ 5

Question Number : 15 Question Id : 7877323015 Display Question Number : Yes Is Question Mandatory : No Calculator : None Response Time : N.A Think Time : N.A Minimum Instruction Time : 0

The threshold voltage of an n-channel enhancement mode MOSFET is 0.5 V. when the device is biased at a gate voltage of 3 V, saturation would occur at a drain voltage of:

Options :

1. ✘ 2 V

2. ✔ 2.5 V

3. ✘ 3 V

4. ✘ 1.5 V

Question Number : 16 Question Id : 7877323016 Display Question Number : Yes Is Question Mandatory : No Calculator : None Response Time : N.A Think Time : N.A Minimum Instruction Time : 0

The ($I_d - V_{gs}$) characteristics of a MOSFET in the saturation region is

Options :

1. ✘ Exponential
2. ✔ Quadratic
3. ✘ Logarithmic
4. ✘ Hyperbolic

Question Number : 17 Question Id : 7877323017 Display Question Number : Yes Is Question Mandatory : No Calculator : None Response Time : N.A Think Time : N.A Minimum Instruction Time : 0

Oscillators operate on the principle of

Options :

1. ✔ Positive feedback
2. ✘ Negative feedback
3. ✘ Signal feedthrough
4. ✘ Attenuation

Question Number : 18 Question Id : 7877323018 Display Question Number : Yes Is Question

Mandatory : No Calculator : None Response Time : N.A Think Time : N.A Minimum Instruction Time : 0

In a transistor-based oscillator, the total loop gain required to sustain oscillation is

Options :

1. ✓ 1

2. ✗ 0.5

3. ✗ $-1/2$

4. ✗ 0

Question Number : 19 Question Id : 7877323019 Display Question Number : Yes Is Question Mandatory : No Calculator : None Response Time : N.A Think Time : N.A Minimum Instruction Time : 0

A certain differential amplifier has a differential voltage gain of 2000 and a common mode gain of 0.2. The CMRR is:

Options :

1. ✓ 80 dB

2. ✗ 200 dB

3. ✗ 100 dB

4.

✘ 1000 dB

Question Number : 20 Question Id : 7877323020 Display Question Number : Yes Is Question Mandatory : No Calculator : None Response Time : N.A Think Time : N.A Minimum Instruction Time : 0

A special case of non-inverting amplifier in which all of the output voltage is fed back to the inverting input of the op-amp is called:

Options :

1. ✘ Differentiator

2. ✘ Integrator

3. ✘ Logarithmic amplifier

4. ✔ Voltage follower

Question Number : 21 Question Id : 7877323021 Display Question Number : Yes Is Question Mandatory : No Calculator : None Response Time : N.A Think Time : N.A Minimum Instruction Time : 0

The circuit given below is the fixed biasing of the n-channel JFET. The pinch-off voltage and the maximum drain to source current are -8 V and 10 mA , respectively.

What are the values of V_{GSQ} and I_{DQ} , respectively?

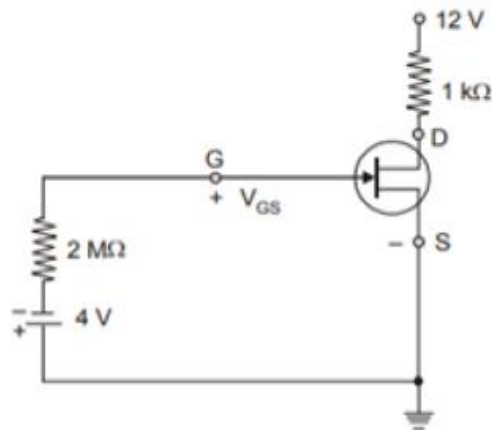

Options :

1. ✘ +4V and 25 mA
2. ✘ +4V and 2.5 mA
3. ✘ -4V and 25 mA
4. ✔ -4V and 2.5 mA

Question Number : 22 Question Id : 7877323022 Display Question Number : Yes Is Question Mandatory : No Calculator : None Response Time : N.A Think Time : N.A Minimum Instruction Time : 0

Consider the following statements regarding JFET:

1. The relationship between the drain current and gate-to-source voltage of a JFET is nonlinear.
2. The minimum current for JFET occurs at pinch-off voltage defined by $V_{GS} = V_P$.
3. A current controlled device is one in which a current defines the operating conditions of the device.

Which of the above statements are correct?

Options :

1. ✓ 1 and 2 only

2. ✗ 1 and 3 only

3. ✗ 1, 2 and 3

4. ✗ 2 and 3 only

Question Number : 23 Question Id : 7877323023 Display Question Number : Yes Is Question Mandatory : No Calculator : None Response Time : N.A Think Time : N.A Minimum Instruction Time : 0

Consider the following statements regarding 555 timer:

1. It operates on -5 V to $+18\text{ V}$ supply voltage in both free running and one-shot modes.
2. It has a high current output and it can source or sink 500 mA .
3. The output can drive TTL and has a temperature stability of 80 parts per million (ppm) per degree Celsius change in temperature or equivalently $0.008\%/^{\circ}\text{C}$.

Which of the above statements are not correct?

Options :

1. ✘ 1 and 2 only

2. ✘ 1 and 3 only

3. ✔ 1, 2 and 3

4. ✘ 2 and 3 only

Question Number : 24 Question Id : 7877323024 Display Question Number : Yes Is Question Mandatory : No Calculator : None Response Time : N.A Think Time : N.A Minimum Instruction Time : 0

Consider the following statements for negative feedback:

1. It has more linear operation
2. It has improved frequency response
3. It has better stabilized voltage gain
4. It has higher output impedance

Which of the above statements are correct?

Options :

1. ✘ 1 and 2 only

2. ✘ 2 and 3 only

3. ✔ 1, 2 and 3 only

4. ✘ 2, 3 and 4 only

Question Number : 25 Question Id : 7877323025 Display Question Number : Yes Is Question Mandatory : No Calculator : None Response Time : N.A Think Time : N.A Minimum Instruction Time : 0

The slope of the output characteristics of a transistor in CE configuration is higher than that in CB configuration due to which one of the following effects?

Options :

1. ✘ Zener effect
2. ✔ Early effect
3. ✘ Avalanche effect
4. ✘ Transistor effect

Question Number : 26 Question Id : 7877323026 Display Question Number : Yes Is Question Mandatory : No Calculator : None Response Time : N.A Think Time : N.A Minimum Instruction Time : 0

Which one of the following statements is correct regarding the comparison between Avalanche and Zener effect?

Options :

1. ✘ Zener effect is caused by impact ionization.
2. ✘ Zener diodes have higher resistance.

3. ✓ Avalanche effect occurs due to impact ionization.

4. ✗ Avalanche diodes have lower resistance

Question Number : 27 Question Id : 7877323027 Display Question Number : Yes Is Question Mandatory : No Calculator : None Response Time : N.A Think Time : N.A Minimum Instruction Time : 0

Which one of the following statements is correct regarding shunt-series feedback amplifier topology?

Options :

1. ✗ The currents are compared and the output voltages are sampled.

2. ✓ The currents are compared and the output currents are sampled.

3. ✗ The voltages are compared and the output currents are sampled.

4. ✗ The voltages are compared and the output voltages are sampled

Question Number : 28 Question Id : 7877323028 Display Question Number : Yes Is Question Mandatory : No Calculator : None Response Time : N.A Think Time : N.A Minimum Instruction Time : 0

Transconductance (g_m) of a MOSFET is given by

Options :

1. ✓ $2I_{DS}/V_{OV}$
2. ✗ $2I_{DS}/(V_{DS}-V_t)$
3. ✗ $I_{DS}/2(V_{GS}-V_t)$
4. ✗ $2I_{DS}/(V_{BS}-V_t)$

Question Number : 29 Question Id : 7877323029 Display Question Number : Yes Is Question Mandatory : No Calculator : None Response Time : N.A Think Time : N.A Minimum Instruction Time : 0

For the configurations shown in Fig, determine the small-signal resistances R_x .

Assume $\lambda \neq 0$.

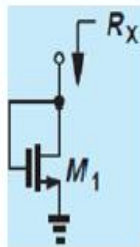

Options :

1. ✗ $r_{O1} + g_{m1}$
2. ✗ $r_{O1} - g_{m1}$
3. ✗ $r_{O1} \parallel g_{m1}$
4. ✓ $r_{O1} \parallel 1/g_{m1}$

Question Number : 30 Question Id : 7877323030 Display Question Number : Yes Is Question Mandatory : No Calculator : None Response Time : N.A Think Time : N.A Minimum Instruction Time : 0

While designing a particular combinational circuit with P and Q as inputs, it is found that " $PQ = 0$ " then " $P \text{ XOR } Q$ " is equal to

Options :

1. ✓ $P+Q$

2. ✗ $P+\overline{Q}$

3. ✗ $\overline{P}+Q$

4. ✗ $\overline{P+Q}$

Question Number : 31 Question Id : 7877323031 Display Question Number : Yes Is Question Mandatory : No Calculator : None Response Time : N.A Think Time : N.A Minimum Instruction Time : 0

Determine the dc bias current of M_1 in the Figure.

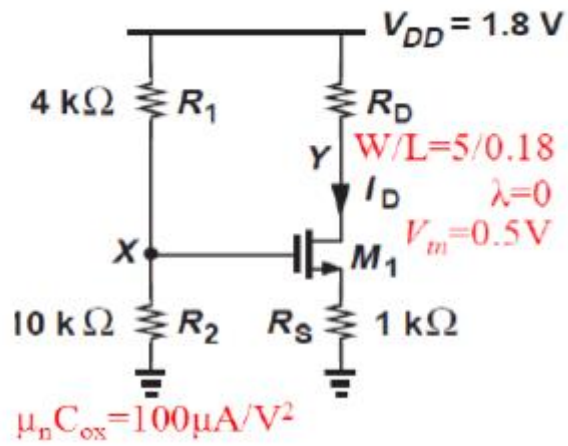

Options :

1. ✘ 310 μA

2. ✔ 312 μA

3. ✘ 314 μA

4. ✘ 316 μA

Question Number : 32 Question Id : 7877323032 Display Question Number : Yes Is Question Mandatory : No Calculator : None Response Time : N.A Think Time : N.A Minimum Instruction Time : 0

A Schmitt trigger circuit achieves hysteresis by utilizing –

Options :

1. ✘ The magnetic properties of a transformer core

2. ✘

Avalanche multiplication in Zener diode

3. ✘ The breakdown principle
4. ✔ Regenerative positive feedback

Question Number : 33 Question Id : 7877323033 Display Question Number : Yes Is Question Mandatory : No Calculator : None Response Time : N.A Think Time : N.A Minimum Instruction Time : 0

Which instruction of 8051 microcontroller is used for reading data from code memory?

Options :

1. ✘ MOV
2. ✔ MOVC
3. ✘ MOVX
4. ✘ XCH

Question Number : 34 Question Id : 7877323034 Display Question Number : Yes Is Question Mandatory : No Calculator : None Response Time : N.A Think Time : N.A Minimum Instruction Time : 0

Consider the following statement regarding microprocessor and microcontrollers

1. A microcontroller is a single, very large scale integrated chip that contains programmable electronics component
2. Address bus carries the signals relating to control actions
3. A microcomputer consists of a central processing unit I/O interface and memory block

Which of the above statements are correct?

Options :

1. ✘ 1 and 2 only

2. ✘ 2 and 3 only

3. ✘ 1 and 3 only

4. ✔ 1, 2 and 3

Question Number : 35 Question Id : 7877323035 Display Question Number : Yes Is Question Mandatory : No Calculator : None Response Time : N.A Think Time : N.A Minimum Instruction Time : 0

Which is used for storing the one-bit digital data?

Options :

1. ✘ NAND GATE

2. ✘ GATE

3. ✓ Flipflop

4. ✘ Register

Question Number : 36 Question Id : 7877323036 Display Question Number : Yes Is Question Mandatory : No Calculator : None Response Time : N.A Think Time : N.A Minimum Instruction Time : 0

Which of the following logic families has the maximum noise margin?

Options :

1. ✘ DTL

2. ✘ RTL

3. ✘ ECL

4. ✓ CMOS

Question Number : 37 Question Id : 7877323037 Display Question Number : Yes Is Question Mandatory : No Calculator : None Response Time : N.A Think Time : N.A Minimum Instruction Time : 0

Which of the following is a combinational logic circuit that has 2^n input lines and a single output line?

Options :

1. ✘ Demultiplexer

2. ✘ Decoder

3. ✘ Encoder

4. ✔ Multiplexer

Question Number : 38 Question Id : 7877323038 Display Question Number : Yes Is Question Mandatory : No Calculator : None Response Time : N.A Think Time : N.A Minimum Instruction Time : 0

How many flip-flops are required to design Mod-20 counter?

Options :

1. ✘ 10

2. ✘ 4

3. ✘ 20

4. ✔ 5

Question Number : 39 Question Id : 7877323039 Display Question Number : Yes Is Question Mandatory : No Calculator : None Response Time : N.A Think Time : N.A Minimum Instruction Time : 0

In a Johnson's counter, all the negative triggered J-K flip-flops are used. Initially all the flip-flops are in reset condition and the outputs are $Q_3Q_2Q_1Q_0 = 0000$. What are the outputs of the flip-flops after the fifth negative going pulse?

Options :

$$Q_3Q_2Q_1Q_0 = 0101$$

1. ✘

$$Q_3Q_2Q_1Q_0 = 1000$$

2. ✘

$$Q_3Q_2Q_1Q_0 = 0010$$

3. ✘

$$Q_3Q_2Q_1Q_0 = 1110$$

4. ✔

Question Number : 40 Question Id : 7877323040 Display Question Number : Yes Is Question Mandatory : No Calculator : None Response Time : N.A Think Time : N.A Minimum Instruction Time : 0

8086 is _____ bit microprocessor.

Options :

1. ✘ 8

2. ✔ 16

3. ✘ 24

4. ✘ 64

Question Number : 41 Question Id : 7877323041 Display Question Number : Yes Is Question Mandatory : No Calculator : None Response Time : N.A Think Time : N.A Minimum Instruction Time : 0

The external interrupts of 8051 microcontroller are

Options :

1. ✘ TRAP and INT1

2. ✔ INT0 and INT1

3. ✘ INT2 and INT1

4. ✘ TRAP and INTR

Question Number : 42 Question Id : 7877323042 Display Question Number : Yes Is Question Mandatory : No Calculator : None Response Time : N.A Think Time : N.A Minimum Instruction Time : 0

In a Binary-coded Decimal (BCD) systems, the decimal number 81 is represented as

Options :

1. ✔ 10000001

2. ✘ 10100010

3. ✘ 01010001

4. ✘ 00011000

Question Number : 43 Question Id : 7877323043 Display Question Number : Yes Is Question Mandatory : No Calculator : None Response Time : N.A Think Time : N.A Minimum Instruction Time : 0

Octal equivalent of number $(236)_{16}$ is

Options :

1. ✘ 1065

2. ✔ 1066

3. ✘ 1067

4. ✘ 1068

Question Number : 44 Question Id : 7877323044 Display Question Number : Yes Is Question Mandatory : No Calculator : None Response Time : N.A Think Time : N.A Minimum Instruction Time : 0

Which are the two basic operations performed in ADC?

Options :

1. ✘ Counting and approximation

2. ✘ Addition and comparison

3. ✓ Quantization and coding

4. ✗ Counting and addition

Question Number : 45 Question Id : 7877323045 Display Question Number : Yes Is Question Mandatory : No Calculator : None Response Time : N.A Think Time : N.A Minimum Instruction Time : 0

As compared to TTL, CMOS logic has

Options :

1. ✗ High speed of operation

2. ✗ Higher power dissipation

3. ✓ Smaller physical size

4. ✗ Larger physical size

Question Number : 46 Question Id : 7877323046 Display Question Number : Yes Is Question Mandatory : No Calculator : None Response Time : N.A Think Time : N.A Minimum Instruction Time : 0

A digital signal processing system described by the expression

$$Y(n) = 2x(n) + x(n-1) + 2y(n-1) \text{ is}$$

Options :

1. ✘ A stable FIR filter
2. ✘ A stable IIR filter
3. ✘ An unstable FIR filter
4. ✔ An unstable IIR filter

Question Number : 47 Question Id : 7877323047 Display Question Number : Yes Is Question Mandatory : No Calculator : None Response Time : N.A Think Time : N.A Minimum Instruction Time : 0

Consider a system equation $y(n+2) = -3x(n+2) + 2x(n) - 5x(n-1)$, the system is _____ and _____ respectively.

Options :

1. ✘ non-causal, IIR
2. ✘ casual, IIR
3. ✘ non-causal, FIR
4. ✔ casual, FIR

Question Number : 48 Question Id : 7877323048 Display Question Number : Yes Is Question

Mandatory : No Calculator : None Response Time : N.A Think Time : N.A Minimum Instruction Time : 0

Consider the following statements pertaining to FIR filters:

1. These are recursive and hence stability is not guaranteed.
2. These have high coefficient sensitivity.
3. These have linear phase characteristics.
4. These are realized using feedback structures.

Which of the above statements are correct?

Options :

1. ✘ 1, 2, and 4

2. ✘ 2, 3 and 4

3. ✔ only 3

4. ✘ only 4

Question Number : 49 Question Id : 7877323049 Display Question Number : Yes Is Question Mandatory : No Calculator : None Response Time : N.A Think Time : N.A Minimum Instruction Time : 0

The highest frequency component of a speech signal needed for telephonic communication is about 3.1 KHz. What is the suitable value for the sampling rate?

Options :

1. ✘ 1 KHz

2. ✘ 2 KHz

3. ✘ 4 KHz

4. ✔ 8 KHz

Question Number : 50 Question Id : 7877323050 Display Question Number : Yes Is Question Mandatory : No Calculator : None Response Time : N.A Think Time : N.A Minimum Instruction Time : 0

A band limited signal with a maximum frequency of 5 kHz is to be sampled.

According to the sampling theorem, the sampling frequency which is not valid is

Options :

1. ✘ 5 kHz

2. ✘ 12 kHz

3. ✘ 15 kHz

4. ✔ 20 kHz

Question Number : 51 Question Id : 7877323051 Display Question Number : Yes Is Question Mandatory : No Calculator : None Response Time : N.A Think Time : N.A Minimum Instruction Time : 0

What does the signalling rate in the digital communication system imply?

Options :

1. ✓ Number of digital pulses transmitted per second
2. ✘ Number of digital pulses transmitted per minute
3. ✘ Number of digital pulses received per second
4. ✘ Number of digital pulses received per minute

Question Number : 52 Question Id : 7877323052 Display Question Number : Yes Is Question Mandatory : No Calculator : None Response Time : N.A Think Time : N.A Minimum Instruction Time : 0

Where is the ROC defined or specified for the signals containing causal as well as anti-causal terms?

Options :

1. ✘ Greater than the largest pole
2. ✘ Less than the smallest pole
3. ✓ Between two poles
4. ✘ Cannot be defined

Question Number : 53 Question Id : 7877323053 Display Question Number : Yes Is Question

Mandatory : No Calculator : None Response Time : N.A Think Time : N.A Minimum Instruction Time : 0

Which phenomenon occurs due to an increase in the channel bandwidth during the transmission of narrow pulses in order to avoid any intervention of signal distortion?

Options :

1. ✘ Compression in time domain
2. ✘ Expansion in time domain
3. ✘ Compression in frequency domain
4. ✔ Expansion in frequency domain

Question Number : 54 Question Id : 7877323054 Display Question Number : Yes Is Question Mandatory : No Calculator : None Response Time : N.A Think Time : N.A Minimum Instruction Time : 0

An equalizer used to compensate the distortion in the communication system by faithful recovery of an original signal is nothing but an illustration of _____

Options :

1. ✘ Static system
2. ✘ Dynamic system
3. ✔ Invertible system

Non-invertible system

4. ✘

Question Number : 55 Question Id : 7877323055 Display Question Number : Yes Is Question Mandatory : No Calculator : None Response Time : N.A Think Time : N.A Minimum Instruction Time : 0

In a communication system, noise is most likely to affect the signal

Options :

1. ✘ At the transmitter
2. ✔ In the channel or in the transmission line
3. ✘ In the information source
4. ✘ At the receiver

Question Number : 56 Question Id : 7877323056 Display Question Number : Yes Is Question Mandatory : No Calculator : None Response Time : N.A Think Time : N.A Minimum Instruction Time : 0

AM is used for broadcasting because

Options :

1. ✘ It is more noise immune than other modulation systems
2. ✘ It requires less transmitting power compared with other systems

3. ✓ Its use avoids receiver complexity

No other modulation system can provide the necessary bandwidth faithful transmission

4. ✘

Question Number : 57 Question Id : 7877323057 Display Question Number : Yes Is Question Mandatory : No Calculator : None Response Time : N.A Think Time : N.A Minimum Instruction Time : 0

The power spectral density of a signal is

Options :

1. ✘ Even negative and complex

2. ✘ odd complex and positive

3. ✘ real, odd and negative

4. ✓ real, even and non-negative

Question Number : 58 Question Id : 7877323058 Display Question Number : Yes Is Question Mandatory : No Calculator : None Response Time : N.A Think Time : N.A Minimum Instruction Time : 0

A white noise having magnitude $0.001 \mu\text{W}/\text{Hz}$ is applied to an RC low pass filter of $R = 1 \text{ k}\Omega$ and $C = 0.1 \mu\text{F}$. The output noise power of the RC low-pass filter equals

Options :

1. ✘ 0.5 μW

2. ✘ 1.5 μW

3. ✔ 2.5 μW

4. ✘ 3.5 μW

Question Number : 59 Question Id : 7877323059 Display Question Number : Yes Is Question Mandatory : No Calculator : None Response Time : N.A Think Time : N.A Minimum Instruction Time : 0

FIR filter having anti-symmetrical impulse response with even filter order can be used to design

Options :

1. ✘ low-pass, high-pass, band-pass and band-stop

2. ✘ low-pass and band-pass only

3. ✘ high-pass and band-stop only

4. ✔ differentiator and Hilbert transformer

Question Number : 60 Question Id : 7877323060 Display Question Number : Yes Is Question Mandatory : No Calculator : None Response Time : N.A Think Time : N.A Minimum Instruction

Time : 0

Basically, poles of transfer function are the Laplace transform variable values which causes the transfer function to become _____

Options :

1. ✘ Zero
2. ✘ Unity
3. ✔ Infinite
4. ✘ Average value

Question Number : 61 Question Id : 7877323061 Display Question Number : Yes Is Question Mandatory : No Calculator : None Response Time : N.A Think Time : N.A Minimum Instruction Time : 0

Which among the following is not an advantage of an open loop system?

Options :

1. ✘ Simplicity in construction & design
2. ✘ Easy maintenance
3. ✘ Rare problems of stability
4. ✔ Requirement of system recalibration from time to time

Question Number : 62 Question Id : 7877323062 Display Question Number : Yes Is Question Mandatory : No Calculator : None Response Time : N.A Think Time : N.A Minimum Instruction Time : 0

If a Nyquist plot of $G(j\omega)H(j\omega)$ for a closed loop system passes through $(-2, j0)$ point in GH plane, what would be the value of gain margin of the system?

Options :

1. ✘ 0 dB
2. ✘ 2.0201 dB
3. ✘ 4 dB
4. ✔ 6.0205 dB

Question Number : 63 Question Id : 7877323063 Display Question Number : Yes Is Question Mandatory : No Calculator : None Response Time : N.A Think Time : N.A Minimum Instruction Time : 0

Consider a feedback system with gain margin of about 30. At what point does Nyquist plot cross negative real axis?

Options :

1. ✘ -3
2. ✔ -0.3

3. ✘ -30

4. ✘ -0.03

Question Number : 64 Question Id : 7877323064 Display Question Number : Yes Is Question Mandatory : No Calculator : None Response Time : N.A Think Time : N.A Minimum Instruction Time : 0

If the system is represented by $G(s)H(s) = \frac{k(s+7)}{s(s+3)(s+2)}$ what would be its magnitude at $\omega = \infty$?

Options :

1. ✔ 0

2. ✘ ∞

3. ✘ 7/10

4. ✘ 21

Question Number : 65 Question Id : 7877323065 Display Question Number : Yes Is Question Mandatory : No Calculator : None Response Time : N.A Think Time : N.A Minimum Instruction Time : 0

If the unity feedback system is given by the open loop transfer function

$G(s) = \frac{ks^2}{(1+0.3s)(1+0.05s)}$, what would be the initial slope of magnitude plot?

Options :

1. ✘ 20 dB/decade

2. ✔ 40 dB/decade

3. ✘ 60 dB/decade

4. ✘ Unpredictable

Question Number : 66 Question Id : 7877323066 Display Question Number : Yes Is Question Mandatory : No Calculator : None Response Time : N.A Think Time : N.A Minimum Instruction Time : 0

The system is said to be marginally stable, if gain margin is _____

Options :

1. ✔ 0

2. ✘ 1

3. ✘ $+\infty$

4. ✘ either 0 or 1

Question Number : 67 Question Id : 7877323067 Display Question Number : Yes Is Question Mandatory : No Calculator : None Response Time : N.A Think Time : N.A Minimum Instruction Time : 0

If the system is represented by characteristic equation $s^6 + s^4 + s^3 + s^2 + s + 3 = 0$, then the system is _____

Options :

1. ✘ Stable
2. ✔ Unstable
3. ✘ Marginally stable
4. ✘ Unpredictable

Question Number : 68 Question Id : 7877323068 Display Question Number : Yes Is Question Mandatory : No Calculator : None Response Time : N.A Think Time : N.A Minimum Instruction Time : 0

Consider the equation $s^3 + 3s^2 + 5s + 2 = 0$. How many roots are located in left half of s-plane?

Options :

1. ✘ Zero
2. ✘ Two
3. ✔ Three
4. ✘ Four

Question Number : 69 Question Id : 7877323069 Display Question Number : Yes Is Question Mandatory : No Calculator : None Response Time : N.A Think Time : N.A Minimum Instruction Time : 0

At summing point, more than one signal can be added or _____

Options :

1. ✓ Subtracted
2. ✗ Multiplied
3. ✗ Divided
4. ✗ Exponentiated

Question Number : 70 Question Id : 7877323070 Display Question Number : Yes Is Question Mandatory : No Calculator : None Response Time : N.A Think Time : N.A Minimum Instruction Time : 0

How is the sinusoidal transfer function obtained from the system transfer function in frequency domain?

Options :

1. ✗ Replacement of ' $j\omega$ ' by ' s '
2. ✗ Replacement of ' s ' by ' ω '
3. ✓ Replacement of ' s ' by ' $j\omega$ '

4. ✘ Replacement of 'ω' by 's'

Question Number : 71 Question Id : 7877323071 Display Question Number : Yes Is Question Mandatory : No Calculator : None Response Time : N.A Think Time : N.A Minimum Instruction Time : 0

In a second order system, if the damping ratio is greater than equal to '1', then what would be the nature of roots?

Options :

1. ✘ Imaginary
2. ✘ Real and equal
3. ✔ Real but not equal
4. ✘ Complex conjugate

Question Number : 72 Question Id : 7877323072 Display Question Number : Yes Is Question Mandatory : No Calculator : None Response Time : N.A Think Time : N.A Minimum Instruction Time : 0

For the elimination of feedback loops, the derivation based on transfer function of _____ loop is used.

Options :

1. ✘ Open

2. ✓ Closed

3. ✗ Neither open nor closed

4. ✗ Either open or closed

Question Number : 73 Question Id : 7877323073 Display Question Number : Yes Is Question Mandatory : No Calculator : None Response Time : N.A Think Time : N.A Minimum Instruction Time : 0

In P-I controller, what does an integral of a function compute?

Options :

1. ✗ Density of curve

2. ✓ Area under the curve

3. ✗ Volume over the curve

4. ✗ Circumference of curve

Question Number : 74 Question Id : 7877323074 Display Question Number : Yes Is Question Mandatory : No Calculator : None Response Time : N.A Think Time : N.A Minimum Instruction Time : 0

State space analysis is applicable even if the initial conditions are _____

Options :

1. ✘ Zero

2. ✔ Non-zero

3. ✘ Equal

4. ✘ Not equal

Question Number : 75 Question Id : 7877323075 Display Question Number : Yes Is Question Mandatory : No Calculator : None Response Time : N.A Think Time : N.A Minimum Instruction Time : 0

In polar plots, what does each and every point represent w.r.t magnitude and angle?

Options :

1. ✘ Scalar

2. ✘ Vector

3. ✔ Phasor

4. ✘ Differentiator

Question Number : 76 Question Id : 7877323076 Display Question Number : Yes Is Question Mandatory : No Calculator : None Response Time : N.A Think Time : N.A Minimum Instruction Time : 0

Which one of the following is correct for the given system, $Y[n] = x[n] - x[n - 1]$?

Options :

1. ✓ Time invariant and causal
2. ✗ Time variant and non-causal
3. ✗ Time variant and causal
4. ✗ Time invariant and non-causal

Question Number : 77 Question Id : 7877323077 Display Question Number : Yes Is Question Mandatory : No Calculator : None Response Time : N.A Think Time : N.A Minimum Instruction Time : 0

A discrete time LTI system with rational system function $H(z)$ is causal if and only if

Options :

1. ✓ the ROC is the exterior of a circle outside the outermost pole.
2. ✗ the ROC is the interior of a circle outside the outermost pole
3. ✗ the ROC is the exterior of a circle outside the innermost pole
4. ✗ the ROC is the interior of a circle outside the innermost pole

Question Number : 78 Question Id : 7877323078 Display Question Number : Yes Is Question Mandatory : No Calculator : None Response Time : N.A Think Time : N.A Minimum Instruction Time : 0

Consider the following statements regarding the disadvantages of a passive lead network over an active PD controller:

1. No additional power supplies are required.
2. Noise due to differentiation is reduced.
3. Additional pole does not reduce the number of branches of the root locus that cross the imaginary axis into the right half plane.
4. Addition of the single zero of the PD controller tends to reduce the number of branches of the root locus that cross into the right halfplane.

Which of the above statements is/are correct?

Options :

1. ✘ 1 only
2. ✘ 2 only
3. ✔ 3 and 4 only
4. ✘ 1, 2 and 4 only

Question Number : 79 Question Id : 7877323079 Display Question Number : Yes Is Question Mandatory : No Calculator : None Response Time : N.A Think Time : N.A Minimum Instruction Time : 0

Electrode to measure EEG are placed on _____

Options :

1. ✘ Forehead
2. ✔ Scalp
3. ✘ Cheek
4. ✘ Ears

Question Number : 80 Question Id : 7877323080 Display Question Number : Yes Is Question Mandatory : No Calculator : None Response Time : N.A Think Time : N.A Minimum Instruction Time : 0

What is the full form of ECG?

Options :

1. ✘ Electricity cardiac group
2. ✘ Electrocardio group
3. ✘ Electrocardium granules
4. ✔ Electrocardiogram

Question Number : 81 Question Id : 7877323081 Display Question Number : Yes Is Question Mandatory : No Calculator : None Response Time : N.A Think Time : N.A Minimum Instruction

Time : 0

A mass spectrometer separates ion based on which of the following factor?

Options :

1. ✘ Mass
2. ✘ Charge
3. ✘ Molecular weight
4. ✔ Mass to charge ratio

Question Number : 82 Question Id : 7877323082 Display Question Number : Yes Is Question Mandatory : No Calculator : None Response Time : N.A Think Time : N.A Minimum Instruction Time : 0

Mass spectrometry was discovered by whom?

Options :

1. ✘ Walter Kaufmann
2. ✔ J.J. Thomson
3. ✘ Francis Aston
4. ✘ Ernest O. Lawrence

Question Number : 83 Question Id : 7877323083 Display Question Number : Yes Is Question Mandatory : No Calculator : None Response Time : N.A Think Time : N.A Minimum Instruction Time : 0

The colour of emitted light from LED depends on

Options :

1. ✘ Construction of LED, that is physical dimensions
2. ✘ Number of available carriers
3. ✔ Type of semiconductor material used
4. ✘ Number of recombinations taking place

Question Number : 84 Question Id : 7877323084 Display Question Number : Yes Is Question Mandatory : No Calculator : None Response Time : N.A Think Time : N.A Minimum Instruction Time : 0

When forward biased, LED emits light because of

Options :

1. ✔ Recombination of carriers
2. ✘ Light generated in breaking the covalent bonds
3. ✘ Light produced by collisions

4. ✘ All of the above reasons

Question Number : 85 Question Id : 7877323085 Display Question Number : Yes Is Question Mandatory : No Calculator : None Response Time : N.A Think Time : N.A Minimum Instruction Time : 0

_____ in the laser occurs when photon colliding with an excited atom causes the stimulated emission of a second photon.

Options :

1. ✔ Light amplification

2. ✘ Attenuation

3. ✘ Dispersion

4. ✘ Population inversion

Question Number : 86 Question Id : 7877323086 Display Question Number : Yes Is Question Mandatory : No Calculator : None Response Time : N.A Think Time : N.A Minimum Instruction Time : 0

In a photodiode, when there is no incident light, the reverse current is almost negligible and is called

Options :

1. ✘ Zener current

2. ✓ Dark current

3. ✘ Photocurrent

4. ✘ PIN current

Question Number : 87 Question Id : 7877323087 Display Question Number : Yes Is Question Mandatory : No Calculator : None Response Time : N.A Think Time : N.A Minimum Instruction Time : 0

In a photodiode, for high speed operation, the depletion region must be

Options :

1. ✘ Zero

2. ✘ Thin

3. ✓ Very large

4. ✘ Large

Question Number : 88 Question Id : 7877323088 Display Question Number : Yes Is Question Mandatory : No Calculator : None Response Time : N.A Think Time : N.A Minimum Instruction Time : 0

_____ works by merging two or more sources of light to create an interference pattern, which can be measured and analysed.

Options :

1. ✓ Interferometer
2. ✘ Power Meter
3. ✘ Optical Meter
4. ✘ Tachometer

Question Number : 89 Question Id : 7877323089 Display Question Number : Yes Is Question Mandatory : No Calculator : None Response Time : N.A Think Time : N.A Minimum Instruction Time : 0

The fibres not used nowadays for optical fibre communication system are

Options :

1. ✓ Single-mode fibre
2. ✘ Multimode fibre
3. ✘ Coaxial cable
4. ✘ Multimode graded-index fibres

Question Number : 90 Question Id : 7877323090 Display Question Number : Yes Is Question Mandatory : No Calculator : None Response Time : N.A Think Time : N.A Minimum Instruction Time : 0

A galvanometer is used to _____

Options :

1. ✘ Detect the direction of light
2. ✔ Detect the direction of current
3. ✘ Detect the direction of magnetic induction
4. ✘ Detect the direction of sound

Question Number : 91 Question Id : 7877323091 Display Question Number : Yes Is Question Mandatory : No Calculator : None Response Time : N.A Think Time : N.A Minimum Instruction Time : 0

When the pointer of an indicating instrument is in motion, then the deflecting torque is opposed by

Options :

1. ✘ Damping torque
2. ✔ Controlling torque
3. ✘ Both damping torque and controlling torque

Rotating torque

4. ✘

Question Number : 92 Question Id : 7877323092 Display Question Number : Yes Is Question Mandatory : No Calculator : None Response Time : N.A Think Time : N.A Minimum Instruction Time : 0

The difference between the indicated value and the true value of a quantity is

Options :

1. ✘ Gross error

2. ✔ Absolute error

3. ✘ Dynamic error

4. ✘ Relative error

Question Number : 93 Question Id : 7877323093 Display Question Number : Yes Is Question Mandatory : No Calculator : None Response Time : N.A Think Time : N.A Minimum Instruction Time : 0

A galvanometer may be converted into ammeter or voltmeter. In which of the following case the resistance of the device will be the largest?

Options :

1. ✘ An ammeter of range 10 A

2. ✘ A voltmeter of range 5 volt

3. ✘ An ammeter of range 5 A

4. ✔ A voltmeter of range 10 V

Question Number : 94 Question Id : 7877323094 Display Question Number : Yes Is Question Mandatory : No Calculator : None Response Time : N.A Think Time : N.A Minimum Instruction Time : 0

Error due to improper zero adjustment is classified as

Options :

1. ✘ Environmental error

2. ✔ Instrument error

3. ✘ Random error

4. ✘ Operator error

Question Number : 95 Question Id : 7877323095 Display Question Number : Yes Is Question Mandatory : No Calculator : None Response Time : N.A Think Time : N.A Minimum Instruction Time : 0

Deflection methods of direct measurements are most widely used as these are

Options :

1. ✘ most simple
2. ✘ most accurate
3. ✘ least time consuming
4. ✔ most simple and least time consuming

Question Number : 96 Question Id : 7877323096 Display Question Number : Yes Is Question Mandatory : No Calculator : None Response Time : N.A Think Time : N.A Minimum Instruction Time : 0

_____ is a variable displacement transducer.

Options :

1. ✔ Potentiometer
2. ✘ Tachometer
3. ✘ Synchros
4. ✘ Multimeter

Question Number : 97 Question Id : 7877323097 Display Question Number : Yes Is Question

Mandatory : No Calculator : None Response Time : N.A Think Time : N.A Minimum Instruction Time : 0

Which of the following part is called as heart of CRO?

Options :

1. ✘ Sweep generator
2. ✘ Trigger circuit
3. ✔ CRT
4. ✘ Amplifier

Question Number : 98 Question Id : 7877323098 Display Question Number : Yes Is Question Mandatory : No Calculator : None Response Time : N.A Think Time : N.A Minimum Instruction Time : 0

Which of the following is the measurement in digital voltmeter?

Options :

1. ✘ 1V to 1KV
2. ✔ 1V to 1MV
3. ✘ 1KV to 1MV
4. ✘ 100 KV to 100MV

Question Number : 99 Question Id : 7877323099 Display Question Number : Yes Is Question Mandatory : No Calculator : None Response Time : N.A Think Time : N.A Minimum Instruction Time : 0

A bridge circuit uses _____ method of measurement.

Options :

1. ✘ Relative
2. ✘ Absolute
3. ✔ Comparison
4. ✘ Differential

Question Number : 100 Question Id : 7877323100 Display Question Number : Yes Is Question Mandatory : No Calculator : None Response Time : N.A Think Time : N.A Minimum Instruction Time : 0

Moving coil permanent magnet instrument can be used for the measurement of

Options :

1. ✘ AC and DC
2. ✘ AC only
3. ✔ DC only

Half-wave rectified DC

4. ✘

Question Number : 101 Question Id : 7877323101 Display Question Number : Yes Is Question Mandatory : No Calculator : None Response Time : N.A Think Time : N.A Minimum Instruction Time : 0

Function of transducer is to convert

Options :

1. ✘ Electrical signal into nonelectrical quantity

2. ✔ Nonelectrical quantity into electrical signal

3. ✘ Electrical signal into mechanical quantity

4. ✘ All of the above

Question Number : 102 Question Id : 7877323102 Display Question Number : Yes Is Question Mandatory : No Calculator : None Response Time : N.A Think Time : N.A Minimum Instruction Time : 0

Which of the following type of signal can be generated by a mechanical transducer?

Options :

1. ✘ chemical ion type signal

2. ✘ biological response type signal

3. ✘ electrical type signal

4. ✔ physical quantity type

Question Number : 103 Question Id : 7877323103 Display Question Number : Yes Is Question Mandatory : No Calculator : None Response Time : N.A Think Time : N.A Minimum Instruction Time : 0

Seismic transducer may be used in _____ mode.

Options :

1. ✘ In-active

2. ✘ Static

3. ✔ Displacement

4. ✘ Low velocity

Question Number : 104 Question Id : 7877323104 Display Question Number : Yes Is Question Mandatory : No Calculator : None Response Time : N.A Think Time : N.A Minimum Instruction Time : 0

For which one of the following measurement a thermistor can be used?

Options :

1. ✘ Velocity

2. ✘ Humidity

3. ✘ Displacement

4. ✔ Temperature

Question Number : 105 Question Id : 7877323105 Display Question Number : Yes Is Question Mandatory : No Calculator : None Response Time : N.A Think Time : N.A Minimum Instruction Time : 0

The temperature coefficient of resistance for a thermistor is

Options :

1. ✘ Low and negative

2. ✘ Low and positive

3. ✔ High and negative

4. ✘ High and positive

Question Number : 106 Question Id : 7877323106 Display Question Number : Yes Is Question Mandatory : No Calculator : None Response Time : N.A Think Time : N.A Minimum Instruction Time : 0

Resistance thermometer elements made from semiconductor compounds is called

Options :

1. ✘ Hot wire anemometer
2. ✘ Semiconductor temperature sensors
3. ✔ Thermistors
4. ✘ Hot wire resistance transducer

Question Number : 107 Question Id : 7877323107 Display Question Number : Yes Is Question Mandatory : No Calculator : None Response Time : N.A Think Time : N.A Minimum Instruction Time : 0

LVDT can be used for

Options :

1. ✘ Vibration measurement
2. ✘ Angular velocity measurement
3. ✔ Force measurement in a beam
4. ✘ Load measurement on a column

Question Number : 108 Question Id : 7877323108 Display Question Number : Yes Is Question

Mandatory : No Calculator : None Response Time : N.A Think Time : N.A Minimum Instruction Time : 0

Which of the following transducer measure the pressure by producing emf as a function of its deformation?

Options :

1. ✘ Photoelectric transducer
2. ✘ Capacitive transducer
3. ✘ Inductive transducer
4. ✔ Piezoelectric transducer

Question Number : 109 Question Id : 7877323109 Display Question Number : Yes Is Question Mandatory : No Calculator : None Response Time : N.A Think Time : N.A Minimum Instruction Time : 0

Capacitive transducers are normally employed for _____ measurement.

Options :

1. ✘ Transient only
2. ✔ Both static and dynamic
3. ✘ Static only

4. ✘ Dynamic only

Question Number : 110 Question Id : 7877323110 Display Question Number : Yes Is Question Mandatory : No Calculator : None Response Time : N.A Think Time : N.A Minimum Instruction Time : 0

The principle of operation of variable resistance transducer is

Options :

1. ✘ Coupling of two coils changes with displacement
2. ✔ Displacement of a contact slider on a resistance
3. ✘ Deformation leads to change in resistance
4. ✘ Movement of magnetic field produces variation in resistance of material

Question Number : 111 Question Id : 7877323111 Display Question Number : Yes Is Question Mandatory : No Calculator : None Response Time : N.A Think Time : N.A Minimum Instruction Time : 0

For a given matrix A of order 3, $|A| = 32$ and two of its eigen values are 3 & 2.

Find the sum of the eigen values.

Options :

1. ✘ 5
2. ✘

6

3. ✘ 10

4. ✔ 12

Question Number : 112 Question Id : 7877323112 Display Question Number : Yes Is Question Mandatory : No Calculator : None Response Time : N.A Think Time : N.A Minimum Instruction Time : 0

For what values of λ, μ the following equations $x + y + z = 6, x + 2y + 3z = 10,$
 $x + 2y + \lambda z = \mu$ have no solutions.

Options :

1. ✔ $\lambda = 3, \mu \neq 10$

2. ✘ $\lambda \neq 3, \mu = 10$

3. ✘ $\lambda = 3, \mu = 10$

4. ✘ $\lambda \neq 3, \mu \neq 10$

Question Number : 113 Question Id : 7877323113 Display Question Number : Yes Is Question

Mandatory : No Calculator : None Response Time : N.A Think Time : N.A Minimum Instruction

Time : 0

The value of $\iint y \, dx \, dy$, where the region bounded by the parabolas $y^2 = 4x$ and $x^2 = 4y$ is

Options :

1. ✘ $\frac{28}{5}$

2. ✘ $\frac{38}{5}$

3. ✔ $\frac{48}{5}$

4. ✘ $\frac{40}{5}$

Question Number : 114 Question Id : 7877323114 Display Question Number : Yes Is Question

Mandatory : No Calculator : None Response Time : N.A Think Time : N.A Minimum Instruction

Time : 0

If $\vec{r} = x\vec{i} + y\vec{j} + z\vec{k}$ then, $\text{div}(\text{grad } r)$ is

Options :

1. ✘ $\frac{1}{r}$

2. ✔

$$\frac{2}{r}$$

3. ✘ $\frac{3}{r}$

4. ✘ $\frac{4}{r}$

Question Number : 115 Question Id : 7877323115 Display Question Number : Yes Is Question Mandatory : No Calculator : None Response Time : N.A Think Time : N.A Minimum Instruction Time : 0

The value of $6y^2dx - x(x^3 + 2y)dy = 0$ is

Options :

1. ✘ $\frac{y}{x^2} = -\frac{\log x}{2} + C$

2. ✘ $\frac{x}{y^3} = -\frac{\log x}{2} + C$

3. ✔ $\frac{y}{x^3} = -\frac{\log y}{2} + C$

4. ✘

$$\frac{1}{x^3} = \frac{\log y}{2} + C$$

Question Number : 116 Question Id : 7877323116 Display Question Number : Yes Is Question Mandatory : No Calculator : None Response Time : N.A Think Time : N.A Minimum Instruction Time : 0

The value of $x^2 \frac{d^2y}{dx^2} - 3x \frac{dy}{dx} - 5y = 0$ is

Options :

1. ✘ $y = C_1x^{-1} + C_2x^{-3}$

2. ✘ $y = C_1x^{-1} + C_2x^{-5}$

3. ✘ $y = C_1x + C_2x^5$

4. ✔ $y = C_1x^{-1} + C_2x^5$

Question Number : 117 Question Id : 7877323117 Display Question Number : Yes Is Question Mandatory : No Calculator : None Response Time : N.A Think Time : N.A Minimum Instruction Time : 0

The value of $\oint_C \frac{e^{2z}}{(z+1)^5} dz$, where $C : |z| = 2$ is

Options :

1. ✘ $\frac{4\pi i}{3} e^{-1}$

2. ✔ $\frac{4\pi i}{3} e^{-2}$

3. ✘ $\frac{2\pi i}{3} e^{-2}$

4. ✘ $\frac{2\pi i}{3} e^{-1}$

Question Number : 118 Question Id : 7877323118 Display Question Number : Yes Is Question Mandatory : No Calculator : None Response Time : N.A Think Time : N.A Minimum Instruction Time : 0

If $f(z) = \frac{z^2}{(z-1)^2(z+2)}$, then the residue at $z = 1$ is

Options :

1. ✘ $\frac{1}{9}$

2. ✘ $\frac{3}{9}$

3. ✔

$\frac{5}{9}$

4. ✘ $\frac{7}{9}$

Question Number : 119 Question Id : 7877323119 Display Question Number : Yes Is Question Mandatory : No Calculator : None Response Time : N.A Think Time : N.A Minimum Instruction Time : 0

A Continuous random variable X has a Probability Density Function

$f(x) = e^{-x}$, $0 < x < \infty$, then $P\{x > 1\}$ is

Options :

1. ✔ 0.368

2. ✘ 0.5

3. ✘ 0.632

4. ✘ 1.0

Question Number : 120 Question Id : 7877323120 Display Question Number : Yes Is Question Mandatory : No Calculator : None Response Time : N.A Think Time : N.A Minimum Instruction Time : 0

When the Newton-Raphson method is applied to solve the equation

$f(x) = x^3 + 2x - 1 = 0$, the solution at the end of the first iteration with the initial guess value as $x = 1.2$ is

Options :

1. ✘ -0.82

2. ✘ 0.49

3. ✘ 1.69

4. ✔ 0.705