

Telangana State Council Higher Education

Notations :

- 1.Options shown in green color and with ✓ icon are correct.
- 2.Options shown in red color and with ✘ icon are incorrect.

Question Paper Name :	Electrical Engineering 2nd Aug 2022 Shift 2
Subject Name :	Electrical Engineering
Creation Date :	2022-08-02 17:21:09
Duration :	120
Total Marks :	120
Display Marks:	Yes
Calculator :	None
Magnifying Glass Required? :	No
Ruler Required? :	No
Eraser Required? :	No
Scratch Pad Required? :	No
Rough Sketch/Notepad Required? :	No
Protractor Required? :	No
Show Watermark on Console? :	Yes
Highlighter :	No
Auto Save on Console?	Yes
Change Font Color :	No
Change Background Color :	No
Change Theme :	No
Help Button :	No
Show Reports :	No
Show Progress Bar :	No

Electrical Engineering

Group Number :	1
Group Id :	34058042
Group Maximum Duration :	0
Group Minimum Duration :	120
Show Attended Group? :	No
Edit Attended Group? :	No
Break time :	0
Group Marks :	120
Is this Group for Examiner? :	No
Examiner permission :	Cant View
Show Progress Bar? :	No

Mathematics

Section Id :	34058076
Section Number :	1
Section type :	Online
Mandatory or Optional :	Mandatory
Number of Questions :	10
Number of Questions to be attempted :	10
Section Marks :	10
Enable Mark as Answered Mark for Review and Clear Response :	Yes
Maximum Instruction Time :	0
Sub-Section Number :	1
Sub-Section Id :	34058076
Question Shuffling Allowed :	Yes

Question Number : 1 Question Id : 3405804921 Question Type : MCQ Option Shuffling : Yes
Display Question Number : Yes Is Question Mandatory : No Calculator : None Response Time
: N.A Think Time : N.A Minimum Instruction Time : 0

Correct Marks : 1 Wrong Marks : 0

If $A = \begin{bmatrix} 1 & -2 & 4 \\ 2 & -1 & 4 \\ 2 & -4 & 1 \end{bmatrix}$, then $A^4 - A^3 + 11A^2 = kA$, where $k =$

Options :

34058019681. ✘ -20

34058019682. ✘ -21

34058019683. ✘ 20

34058019684. ✔ 21

Question Number : 2 Question Id : 3405804922 Question Type : MCQ Option Shuffling : Yes
Display Question Number : Yes Is Question Mandatory : No Calculator : None Response Time
: N.A Think Time : N.A Minimum Instruction Time : 0

Correct Marks : 1 Wrong Marks : 0

The sum of eigen value of $\begin{bmatrix} 1 & -2 & 1 \\ 2 & -1 & 1 \\ 2 & 1 & -1 \end{bmatrix}$ is

Options :

34058019685. ✘ 1

34058019686. ✔ -1

34058019687. ✖ 2

34058019688. ✖ -2

Question Number : 3 Question Id : 3405804923 Question Type : MCQ Option Shuffling : Yes
Display Question Number : Yes Is Question Mandatory : No Calculator : None Response Time
: N.A Think Time : N.A Minimum Instruction Time : 0

Correct Marks : 1 Wrong Marks : 0

$$\int_0^{\pi} x \sin(3x) dx =$$

Options :

34058019689. ✖ 3π

34058019690. ✖ π

34058019691. ✖ $\frac{2\pi}{3}$

34058019692. ✔ $\frac{\pi}{3}$

Question Number : 4 Question Id : 3405804924 Question Type : MCQ Option Shuffling : Yes
Display Question Number : Yes Is Question Mandatory : No Calculator : None Response Time
: N.A Think Time : N.A Minimum Instruction Time : 0

Correct Marks : 1 Wrong Marks : 0

The domain of the real valued function $f(x) = \sqrt{\cos^{-1}(\log_3 x)}$ is

Options :

34058019693. ✔ $[1, 3]$

34058019694. ✖ [0, 3]

34058019695. ✖ [2, 3]

34058019696. ✖ $\left[\frac{1}{3}, 3\right]$

Question Number : 5 Question Id : 3405804925 Question Type : MCQ Option Shuffling : Yes
Display Question Number : Yes Is Question Mandatory : No Calculator : None Response Time
: N.A Think Time : N.A Minimum Instruction Time : 0

Correct Marks : 1 Wrong Marks : 0

If y_p is the particular integral of $x^2 y'' + y = x^2$ then $y_p =$

Options :

34058019697. ✖ $3x^2$

34058019698. ✖ $\frac{x^2}{3}$

34058019699. ✔ $\frac{x^3}{3}$

34058019700. ✖ $\frac{x}{3}$

Question Number : 6 Question Id : 3405804926 Question Type : MCQ Option Shuffling : Yes
Display Question Number : Yes Is Question Mandatory : No Calculator : None Response Time
: N.A Think Time : N.A Minimum Instruction Time : 0

Correct Marks : 1 Wrong Marks : 0

If f and g are arbitrary functions in $z = f\left(\frac{x}{y}\right) + g\left(\frac{y}{x}\right)$, then the partial differential equation of this family is

Options :

34058019701. ✘ $py + qx = 0$

34058019702. ✘ $px^2 + qy = 0$

34058019703. ✔ $px + qy = 0$

34058019704. ✘ $px + qy^2 = 0$

Question Number : 7 Question Id : 3405804927 Question Type : MCQ Option Shuffling : Yes Display Question Number : Yes Is Question Mandatory : No Calculator : None Response Time : N.A Think Time : N.A Minimum Instruction Time : 0

Correct Marks : 1 Wrong Marks : 0

$$\frac{1}{2\pi i} \int_{|z|=2} \frac{\left(\sum_{k=0}^{2022} z^k\right)}{z^{10}} dz =$$

Options :

34058019705. ✘ 0

34058019706. ✔ 1

34058019707. ✘ 2

34058019708. ✘ 3

Question Number : 8 Question Id : 3405804928 Question Type : MCQ Option Shuffling : Yes
Display Question Number : Yes Is Question Mandatory : No Calculator : None Response Time
: N.A Think Time : N.A Minimum Instruction Time : 0

Correct Marks : 1 Wrong Marks : 0

Z – transform of n^2 is

Options :

34058019709. ✓ $\frac{z(z+1)}{(z-1)^3}$

34058019710. ✘ $\frac{z(z-1)}{(z+1)^3}$

34058019711. ✘ $\frac{z(z+1)}{(z-1)^2}$

34058019712. ✘ $\frac{z(z-1)}{(z+1)^2}$

Question Number : 9 Question Id : 3405804929 Question Type : MCQ Option Shuffling : Yes
Display Question Number : Yes Is Question Mandatory : No Calculator : None Response Time
: N.A Think Time : N.A Minimum Instruction Time : 0

Correct Marks : 1 Wrong Marks : 0

The inverse Laplace transform of $\frac{1}{s^2 + 2s + 3}$ is

Options :

34058019713. ✘ $\frac{\cos(\sqrt{2}t)}{e^t\sqrt{2}}$

34058019714. ✓ $\frac{\sin(\sqrt{2}t)}{e^t\sqrt{2}}$

34058019715. ✗ $\frac{\sin(\sqrt{2}t)}{\sqrt{2}e^{-t}}$

34058019716. ✗ $\frac{\cos(\sqrt{2}t)}{\sqrt{2}e^{-t}}$

Question Number : 10 Question Id : 3405804930 Question Type : MCQ Option Shuffling : Yes Display Question Number : Yes Is Question Mandatory : No Calculator : None Response Time : N.A Think Time : N.A Minimum Instruction Time : 0

Correct Marks : 1 Wrong Marks : 0

If three numbers are chosen at random from the set $\{1, 2, 3, 4, 5, 6, 7, 8, 9, 10\}$, then the probability that the draw contains no prime is

Options :

34058019717. ✗ $\frac{1}{24}$

34058019718. ✓ $\frac{1}{6}$

34058019719. ✗ $\frac{1}{12}$

34058019720. ✗ $\frac{1}{32}$

Electrical Engineering

Section Id :	34058077
Section Number :	2
Section type :	Online
Mandatory or Optional :	Mandatory
Number of Questions :	110
Number of Questions to be attempted :	110
Section Marks :	110
Enable Mark as Answered Mark for Review and Clear Response :	Yes
Maximum Instruction Time :	0
Sub-Section Number :	1
Sub-Section Id :	34058077
Question Shuffling Allowed :	Yes

Question Number : 11 Question Id : 3405804931 Question Type : MCQ Option Shuffling : Yes
Display Question Number : Yes Is Question Mandatory : No Calculator : None Response Time : N.A Think Time : N.A Minimum Instruction Time : 0
Correct Marks : 1 Wrong Marks : 0

In the circuit shown in figure, the switch S is closed at time ($t = 0$). The voltage across the inductor at $t = 0^+$, is

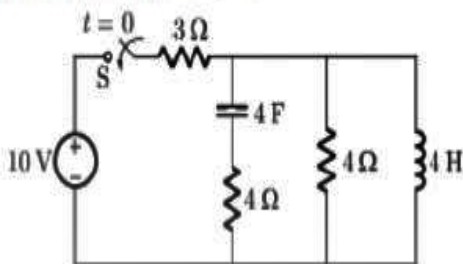

Options :

34058019721. ✖ 2 V

34058019722. ✓ 4 V

34058019723. ✗ -6V

34058019724. ✗ 8 V

Question Number : 12 Question Id : 3405804932 Question Type : MCQ Option Shuffling : Yes
Display Question Number : Yes Is Question Mandatory : No Calculator : None Response Time
: N.A Think Time : N.A Minimum Instruction Time : 0
Correct Marks : 1 Wrong Marks : 0

The Thevenin's Voltage V_{TH} for the circuit shown below is

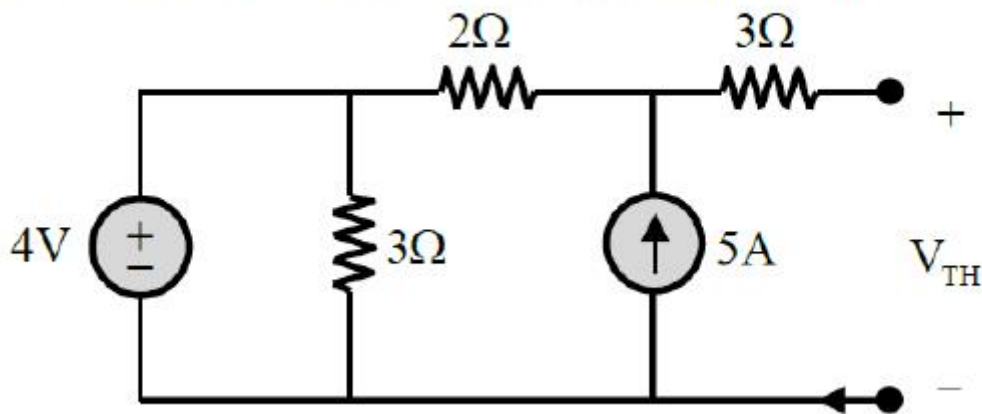

Options :

34058019725. ✓ 14 V

34058019726. ✗ 29 V

34058019727. ✗ 21 V

34058019728. ✗ 10 V

Question Number : 13 Question Id : 3405804933 Question Type : MCQ Option Shuffling : Yes
Display Question Number : Yes Is Question Mandatory : No Calculator : None Response Time

: N.A Think Time : N.A Minimum Instruction Time : 0

Correct Marks : 1 Wrong Marks : 0

For the two-port network shown below, determine the transfer impedance Z_{21}

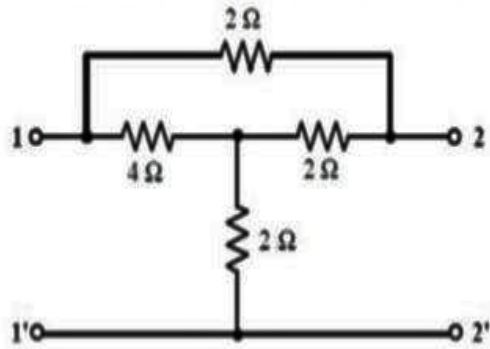

Options :

34058019729. ✘ 1 Ω

34058019730. ✘ 2 Ω

34058019731. ✔ 3 Ω

34058019732. ✘ 4 Ω

Question Number : 14 Question Id : 3405804934 Question Type : MCQ Option Shuffling : Yes

Display Question Number : Yes Is Question Mandatory : No Calculator : None Response Time

: N.A Think Time : N.A Minimum Instruction Time : 0

Correct Marks : 1 Wrong Marks : 0

A source is supplying a load through a 2-phase, 3-wire transmission system as shown in figure below. The instantaneous voltage and current in phase-a are $V_{an} = 220 \sin(100\pi)t$ V and $i_a = 10 \sin(100\pi)t$ A, respectively. Similarly for phase-b the instantaneous voltage and current are $V_{bn} = 220 \cos(100\pi)t$ V and $i_b = 10 \cos(100\pi)t$ A, respectively. The total instantaneous power flowing from the source to the load is

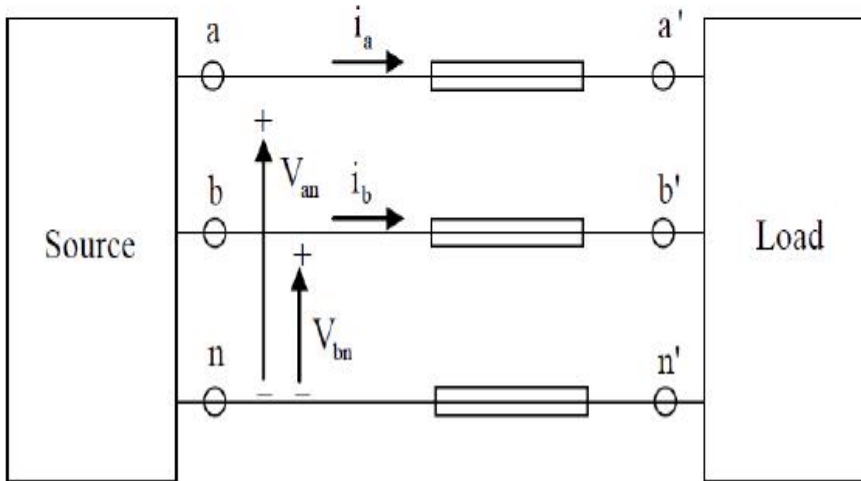

Options :

34058019733. ✘ $2200 \sin^2(100\pi)t$ W

34058019734. ✘ $2200 \sin(100\pi)t \cos(100\pi)t$ W

34058019735. ✘ 220 W

34058019736. ✔ 2200 W

Question Number : 15 Question Id : 3405804935 Question Type : MCQ Option Shuffling : Yes
 Display Question Number : Yes Is Question Mandatory : No Calculator : None Response Time : N.A Think Time : N.A Minimum Instruction Time : 0
 Correct Marks : 1 Wrong Marks : 0

The equivalent resistance between the terminals A and B in the circuit shown below is _____

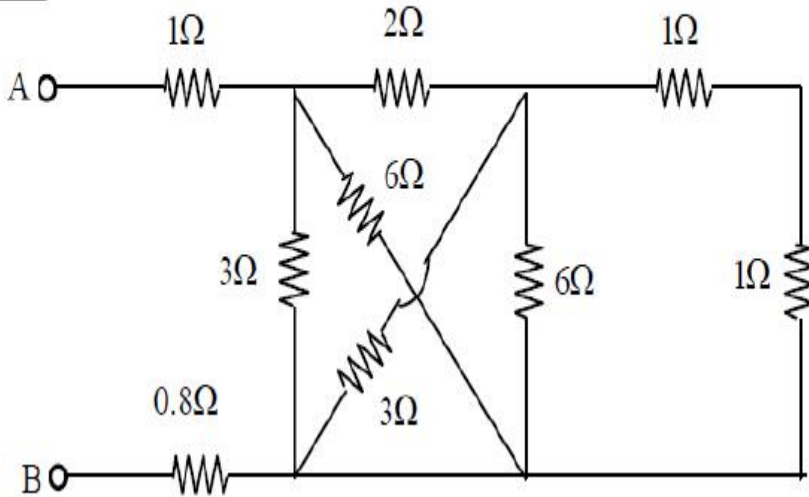

Options :

34058019737. ✓ 3 Ω

34058019738. ✗ 2 Ω

34058019739. ✗ 5 Ω

34058019740. ✗ 6 Ω

Question Number : 16 Question Id : 3405804936 Question Type : MCQ Option Shuffling : Yes Display Question Number : Yes Is Question Mandatory : No Calculator : None Response Time : N.A Think Time : N.A Minimum Instruction Time : 0

Correct Marks : 1 Wrong Marks : 0

The switch in the figure below was closed for a long time. It is opened at $t = 0$. The current in the 2 H inductor at $t = 0^-$ is

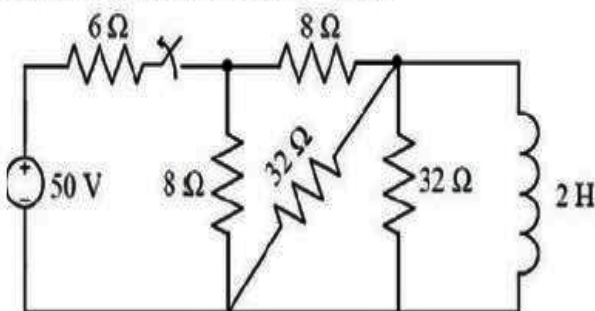

Options :

34058019741. ✘ 5 A

34058019742. ✔ 2.5 A

34058019743. ✘ 4.16 A

34058019744. ✘ 2.08 A

**Question Number : 17 Question Id : 3405804937 Question Type : MCQ Option Shuffling : Yes
Display Question Number : Yes Is Question Mandatory : No Calculator : None Response Time
: N.A Think Time : N.A Minimum Instruction Time : 0**

Correct Marks : 1 Wrong Marks : 0

The magnetic field at a distance 'r' from a long wire carrying current I is 0.4 T.
The magnetic fields at distance '2r' is

Options :

34058019745. ✔ 0.2 T

34058019746. ✘ 0.4 T

34058019747. ✘ 0.8 T

34058019748. ✘ 1.6 T

**Question Number : 18 Question Id : 3405804938 Question Type : MCQ Option Shuffling : Yes
Display Question Number : Yes Is Question Mandatory : No Calculator : None Response Time
: N.A Think Time : N.A Minimum Instruction Time : 0**

Correct Marks : 1 Wrong Marks : 0

In the circuit shown below, the voltage and current are ideal. The voltage (V_{out}) across the current source, in volts, is

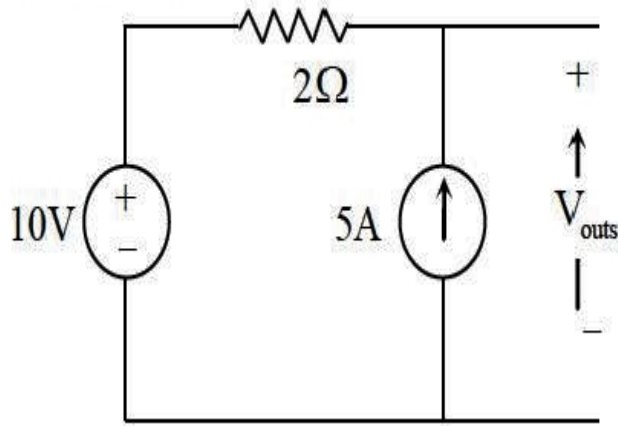

Options :

34058019749. ✘ 10 V

34058019750. ✘ 5 V

34058019751. ✔ 20 V

34058019752. ✘ Zero

Question Number : 19 Question Id : 3405804939 Question Type : MCQ Option Shuffling : Yes
Display Question Number : Yes Is Question Mandatory : No Calculator : None Response Time : N.A Think Time : N.A Minimum Instruction Time : 0

Correct Marks : 1 Wrong Marks : 0

The graph associated with an electrical network has 7 branches and 5 nodes. The number of independent KCL equations and the number of independent KVL equations, respectively, are

Options :

34058019753. ✔ 4 and 3

34058019754. ✘ 3 and 4

34058019755. ✖ 4 and 2

34058019756. ✖ 5 and 2

Question Number : 20 Question Id : 3405804940 Question Type : MCQ Option Shuffling : Yes
Display Question Number : Yes Is Question Mandatory : No Calculator : None Response Time
: N.A Think Time : N.A Minimum Instruction Time : 0

Correct Marks : 1 Wrong Marks : 0

In the circuit shown in the figure the black box contains resistors and independent sources only, the current i is 1.5 A when $R = 0$ and 0.75 A when $R = 2\Omega$, determine the current i when $R = 1\Omega$

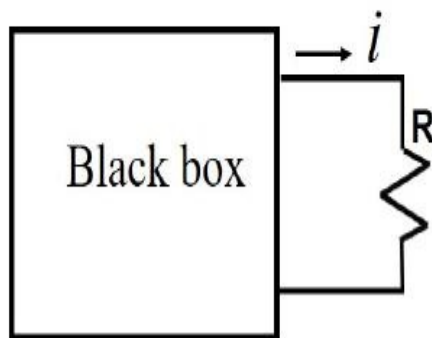

Options :

34058019757. ✖ 1.25 A

34058019758. ✔ 1 A

34058019759. ✖ 1.125 A

34058019760. ✖ 2 A

Question Number : 21 Question Id : 3405804941 Question Type : MCQ Option Shuffling : Yes
Display Question Number : Yes Is Question Mandatory : No Calculator : None Response Time
: N.A Think Time : N.A Minimum Instruction Time : 0

Correct Marks : 1 Wrong Marks : 0

Find the short circuit current flowing through terminals ab in the circuit shown below.

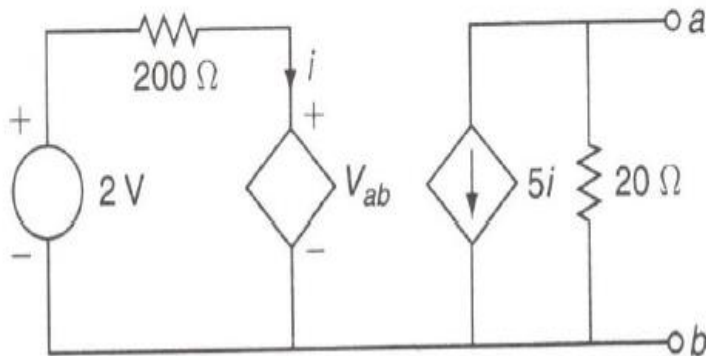

Options :

34058019761. ✓ -0.05 A

34058019762. ✘ 0.1 A

34058019763. ✘ 0.05 A

34058019764. ✘ -0.1 A

Question Number : 22 Question Id : 3405804942 Question Type : MCQ Option Shuffling : Yes Display Question Number : Yes Is Question Mandatory : No Calculator : None Response Time : N.A Think Time : N.A Minimum Instruction Time : 0

Correct Marks : 1 Wrong Marks : 0

A capacitor is made with a polymeric dielectric having an ϵ_r of 2.26 and a dielectric breakdown strength of 50kV/cm. The permittivity of free space is 8.85pF/m. If the rectangular plates of the capacitor have a width of 20cm and a length of 40cm, then the maximum electric charge in the capacitor is

Options :

34058019765. ✘ 2 μC

34058019766. ✘ $4 \mu\text{C}$

34058019767. ✔ $8 \mu\text{C}$

34058019768. ✘ $10 \mu\text{C}$

Question Number : 23 Question Id : 3405804943 Question Type : MCQ Option Shuffling : Yes
Display Question Number : Yes Is Question Mandatory : No Calculator : None Response Time
: N.A Think Time : N.A Minimum Instruction Time : 0

Correct Marks : 1 Wrong Marks : 0

A fully charged mobile phone with a 12 V battery is good for a 10-minute talk time. Assume that during the talk time, the battery delivers a constant current of 2 A and its voltage drops linearly from 12 V to 10 V as shown in the figure. How much energy does the battery deliver during this talk time

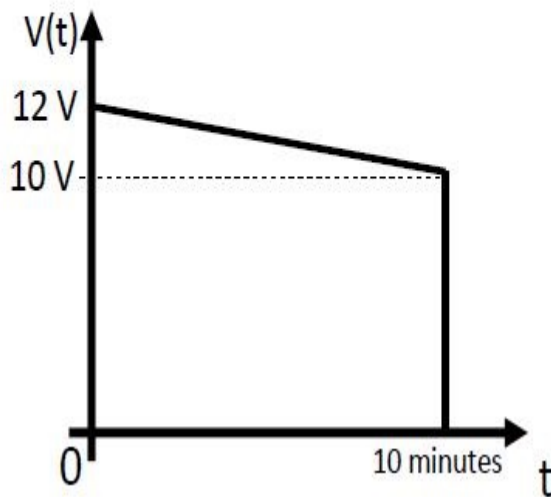

Options :

34058019769. ✘ 14.4 kJ

34058019770. ✔ 13.2 kJ

34058019771. ✘ 12 kJ

34058019772. ✘ 220 J

Question Number : 24 Question Id : 3405804944 Question Type : MCQ Option Shuffling : Yes
Display Question Number : Yes Is Question Mandatory : No Calculator : None Response Time
: N.A Think Time : N.A Minimum Instruction Time : 0

Correct Marks : 1 Wrong Marks : 0

A steel ring of 30 cm mean diameter and circular section 2 cm in diameter has an air gap of length 1 mm. It is wound uniformly with 600 turns of wire carrying current of 2 A. The iron path takes 60 % of total MMF. Find the ratio of reluctance between iron path and air gap

Options :

34058019773. ✓ 1.5

34058019774. ✗ 2

34058019775. ✗ 0.6

34058019776. ✗ 0.4

Question Number : 25 Question Id : 3405804945 Question Type : MCQ Option Shuffling : Yes
Display Question Number : Yes Is Question Mandatory : No Calculator : None Response Time
: N.A Think Time : N.A Minimum Instruction Time : 0

Correct Marks : 1 Wrong Marks : 0

If \vec{E} is the electric field intensity, then $\nabla \cdot (\nabla \times \vec{E})$ is equal to

Options :

34058019777. ✗ \vec{E}

34058019778. ✗ $|\vec{E}|$

34058019779. ✖ Null vector

34058019780. ✔ Zero

Question Number : 26 Question Id : 3405804946 Question Type : MCQ Option Shuffling : Yes Display Question Number : Yes Is Question Mandatory : No Calculator : None Response Time : N.A Think Time : N.A Minimum Instruction Time : 0

Correct Marks : 1 Wrong Marks : 0

At certain value of current, the energy stored in an iron cored coil is 1000 J and its copper loss is 2000 W. The time constant of the coil in seconds is

Options :

34058019781. ✖ 0.25

34058019782. ✖ 0.5

34058019783. ✖ 0.1

34058019784. ✔ 1

Question Number : 27 Question Id : 3405804947 Question Type : MCQ Option Shuffling : Yes Display Question Number : Yes Is Question Mandatory : No Calculator : None Response Time : N.A Think Time : N.A Minimum Instruction Time : 0

Correct Marks : 1 Wrong Marks : 0

A 20 kW, 250 V dc shunt motor has a full-load armature current of 100 A at 2400 rpm. The armature resistance is 0.1 Ω . The internal electromagnetic torque developed is

Options :

34058019785. ✖ 100.8 Nm

34058019786. ✓ 95.5 Nm

34058019787. ✘ 80.9 Nm

34058019788. ✘ Zero Nm

**Question Number : 28 Question Id : 3405804948 Question Type : MCQ Option Shuffling : Yes
Display Question Number : Yes Is Question Mandatory : No Calculator : None Response Time
: N.A Think Time : N.A Minimum Instruction Time : 0**

Correct Marks : 1 Wrong Marks : 0

A 4-pole, 32 conductors, lap-wound DC shunt generator with a terminal voltage of 200V delivers 12A to the load and has armature resistance of 2Ω and field resistance of 200Ω respectively. If it is driven at 1000rpm, the value of generated EMF is

Options :

34058019789. ✘ 100V

34058019790. ✘ 50V

34058019791. ✘ 210V

34058019792. ✓ 226V

**Question Number : 29 Question Id : 3405804949 Question Type : MCQ Option Shuffling : Yes
Display Question Number : Yes Is Question Mandatory : No Calculator : None Response Time
: N.A Think Time : N.A Minimum Instruction Time : 0**

Correct Marks : 1 Wrong Marks : 0

Which of the following quantity is constant in a transformer

Options :

34058019793. ✘ Current

34058019794. ✘ Voltage

34058019795. ✔ Power

34058019796. ✘ Impedance

**Question Number : 30 Question Id : 3405804950 Question Type : MCQ Option Shuffling : Yes
Display Question Number : Yes Is Question Mandatory : No Calculator : None Response Time
: N.A Think Time : N.A Minimum Instruction Time : 0**

Correct Marks : 1 Wrong Marks : 0

In an alternator, the voltage drop occurs in

Options :

34058019797. ✘ Armature resistance only

34058019798. ✘ Armature reaction only

34058019799. ✘ Armature resistance and leakage reactance

34058019800. ✔ Armature resistance, armature reaction and leakage reactance

**Question Number : 31 Question Id : 3405804951 Question Type : MCQ Option Shuffling : Yes
Display Question Number : Yes Is Question Mandatory : No Calculator : None Response Time
: N.A Think Time : N.A Minimum Instruction Time : 0**

Correct Marks : 1 Wrong Marks : 0

A 230V, 50 Hz, 4 pole, single- phase induction motor is rotating in the clockwise (forward) direction at a speed of 1400 rpm. If the rotor resistance at standstill is 7.8Ω , then slip value is

Options :

34058019801. ✖ 0.67

34058019802. ✖ 0

34058019803. ✔ 0.067

34058019804. ✖ 1

Question Number : 32 Question Id : 3405804952 Question Type : MCQ Option Shuffling : Yes Display Question Number : Yes Is Question Mandatory : No Calculator : None Response Time : N.A Think Time : N.A Minimum Instruction Time : 0

Correct Marks : 1 Wrong Marks : 0

The crawling in an induction motor is caused by

Options :

34058019805. ✖ High load

34058019806. ✖ Low voltage supply

34058019807. ✖ Improper design of machine

34058019808. ✔ Harmonics developed in the motor

Question Number : 33 Question Id : 3405804953 Question Type : MCQ Option Shuffling : Yes Display Question Number : Yes Is Question Mandatory : No Calculator : None Response Time : N.A Think Time : N.A Minimum Instruction Time : 0

Correct Marks : 1 Wrong Marks : 0

The open-circuit test in a transformer is used to measure

Options :

34058019809. ✘ Copper loss

34058019810. ✔ Core loss

34058019811. ✘ Total loss

34058019812. ✘ Winding loss

**Question Number : 34 Question Id : 3405804954 Question Type : MCQ Option Shuffling : Yes
Display Question Number : Yes Is Question Mandatory : No Calculator : None Response Time
: N.A Think Time : N.A Minimum Instruction Time : 0**

Correct Marks : 1 Wrong Marks : 0

A sinusoidal maximum flux of 0.01 Wb links with 100 turns of a transformer secondary, the supply frequency is 50 Hz. The r.m.s value of induced e.m.f in the secondary is

Options :

34058019813. ✘ 111V

34058019814. ✘ 232V

34058019815. ✘ Zero V

34058019816. ✔ 222V

Question Number : 35 Question Id : 3405804955 Question Type : MCQ Option Shuffling : Yes

Display Question Number : Yes Is Question Mandatory : No Calculator : None Response Time : N.A Think Time : N.A Minimum Instruction Time : 0

Correct Marks : 1 Wrong Marks : 0

The voltage generated by a dc generator which has two poles and two parallel paths between the brushes, given that flux per pole is 0.01 Wb and each of the four armature coils has 12 turns. The rotor speed is 600rpm.

Options :

34058019817. ✖ 10V

34058019818. ✖ 5V

34058019819. ✔ 9.6V

34058019820. ✖ 10.7V

Question Number : 36 Question Id : 3405804956 Question Type : MCQ Option Shuffling : Yes Display Question Number : Yes Is Question Mandatory : No Calculator : None Response Time : N.A Think Time : N.A Minimum Instruction Time : 0

Correct Marks : 1 Wrong Marks : 0

An ideal 25KVA transformer has 500 turns on the primary winding and 50 turns on the secondary winding. The primary is connected to 5000V, 50 Hz supply. Calculate the secondary current on full-load

Options :

34058019821. ✖ 100A

34058019822. ✔ 500A

34058019823. ✖ 250A

34058019824. ✖ 300A

Question Number : 37 Question Id : 3405804957 Question Type : MCQ Option Shuffling : Yes Display Question Number : Yes Is Question Mandatory : No Calculator : None Response Time : N.A Think Time : N.A Minimum Instruction Time : 0

Correct Marks : 1 Wrong Marks : 0

Synchronous motor run on leading power factor when connected in

Options :

34058019825. ✖ Under excitation

34058019826. ✖ Rated excitation

34058019827. ✖ Fully loaded

34058019828. ✔ Over excitation

Question Number : 38 Question Id : 3405804958 Question Type : MCQ Option Shuffling : Yes Display Question Number : Yes Is Question Mandatory : No Calculator : None Response Time : N.A Think Time : N.A Minimum Instruction Time : 0

Correct Marks : 1 Wrong Marks : 0

A 251 V DC shunt motor has a speed of 1500 rpm and an armature current of 10A at no load. Given that the armature resistance is 0.1Ω , determine the motor speed when the armature current is 20 A

Options :

34058019829. ✖ 1550 rpm

34058019830. ✔ 1494 rpm

34058019831. ✖ Zero rpm

34058019832. ✖ 1100 rpm

**Question Number : 39 Question Id : 3405804959 Question Type : MCQ Option Shuffling : Yes
Display Question Number : Yes Is Question Mandatory : No Calculator : None Response Time
: N.A Think Time : N.A Minimum Instruction Time : 0**

Correct Marks : 1 Wrong Marks : 0

Which motor should not be started on no-load

Options :

34058019833. ✔ DC Series motor

34058019834. ✖ DC Shunt motor

34058019835. ✖ 1-phase Induction Motor

34058019836. ✖ 3-phase Induction Motor

**Question Number : 40 Question Id : 3405804960 Question Type : MCQ Option Shuffling : Yes
Display Question Number : Yes Is Question Mandatory : No Calculator : None Response Time
: N.A Think Time : N.A Minimum Instruction Time : 0**

Correct Marks : 1 Wrong Marks : 0

In a transformer, the losses are due to the resistance of primary and secondary windings is

Options :

34058019837. ✖ Eddy current

34058019838. ✖ Core

34058019839. ✓ Copper

34058019840. ✘ Hystersis

**Question Number : 41 Question Id : 3405804961 Question Type : MCQ Option Shuffling : Yes
Display Question Number : Yes Is Question Mandatory : No Calculator : None Response Time
: N.A Think Time : N.A Minimum Instruction Time : 0**

Correct Marks : 1 Wrong Marks : 0

The speed of DC shunt motor can be increased above rated speed by

Options :

34058019841. ✘ Increasing the supply voltage within its rated value

34058019842. ✘ Increases the flux per pole

34058019843. ✓ Decreasing the flux per pole

34058019844. ✘ Connecting additional resistance in series of the armature

**Question Number : 42 Question Id : 3405804962 Question Type : MCQ Option Shuffling : Yes
Display Question Number : Yes Is Question Mandatory : No Calculator : None Response Time
: N.A Think Time : N.A Minimum Instruction Time : 0**

Correct Marks : 1 Wrong Marks : 0

A 3 phase induction motor with its rotor blocked behaves similar as

Options :

34058019845. ✓ Transformer under short circuit of secondary terminals

34058019846. ✘ Transformer under open circuit of secondary terminals

34058019847. ✘ Synchronous motor under slip test

34058019848. ✘ Synchronous motor under open circuit

**Question Number : 43 Question Id : 3405804963 Question Type : MCQ Option Shuffling : Yes
Display Question Number : Yes Is Question Mandatory : No Calculator : None Response Time
: N.A Think Time : N.A Minimum Instruction Time : 0**

Correct Marks : 1 Wrong Marks : 0

Starters are to be used for starting induction motor to avoid

Options :

34058019849. ✘ Running in reverse direction

34058019850. ✘ High speed

34058019851. ✔ Motor taking five to seven times its full load current

34058019852. ✘ High Starting torque

**Question Number : 44 Question Id : 3405804964 Question Type : MCQ Option Shuffling : Yes
Display Question Number : Yes Is Question Mandatory : No Calculator : None Response Time
: N.A Think Time : N.A Minimum Instruction Time : 0**

Correct Marks : 1 Wrong Marks : 0

When a line to ground fault occurs, the current in a faulted phase is 100A. The zero
sequence current in this case will be

Options :

34058019853. ✘ Zero

34058019854. ✓ 33.3A

34058019855. ✘ 66.6A

34058019856. ✘ 100A

Question Number : 45 Question Id : 3405804965 Question Type : MCQ Option Shuffling : Yes Display Question Number : Yes Is Question Mandatory : No Calculator : None Response Time : N.A Think Time : N.A Minimum Instruction Time : 0

Correct Marks : 1 Wrong Marks : 0

A simple two plant system has the IC's that are $\frac{dC_1}{dP_{G1}} = 0.01P_{G1} + 2.0$,

$\frac{dC_2}{dP_{G2}} = 0.01P_{G2} + 1.5$ and the total load on the system is distributed optimally between

two stations as $P_{G1} = 60MW$ and $P_{G2} = 110MW$, corresponding to $\lambda = 2.6$ and the loss coefficients of the system are given as

M	N	B_{mn}
1	1	0.0015
1	2	-0.0015
2	2	0.0025

The transmission loss is equal to

Options :

34058019857. ✓ 15.85MW

34058019858. ✘ 25.75MW

34058019859. ✘ 35.65MW

34058019860. ✘ 44.85MW

**Question Number : 46 Question Id : 3405804966 Question Type : MCQ Option Shuffling : Yes
Display Question Number : Yes Is Question Mandatory : No Calculator : None Response Time
: N.A Think Time : N.A Minimum Instruction Time : 0**

Correct Marks : 1 Wrong Marks : 0

The penalty factor of the plant having $P_G = 59MW$ (generation power) and
 $P_D = 19MW$ (load demand) is equal to

Options :

34058019861. ✘ 0.6779

34058019862. ✘ 1.475

34058019863. ✘ 0.475

34058019864. ✔ 3.105

**Question Number : 47 Question Id : 3405804967 Question Type : MCQ Option Shuffling : Yes
Display Question Number : Yes Is Question Mandatory : No Calculator : None Response Time
: N.A Think Time : N.A Minimum Instruction Time : 0**

Correct Marks : 1 Wrong Marks : 0

A 125 MVA turbo alternator operator on full load operates at 50 Hz. A load of 50 MW is suddenly reduced on the machine. The steam valves to the turbine commence to close after 0.5 s due to the time lag in the governor system. Assuming the inertia to be constant, $H=6$ kW-s per KVA of the generator capacity, the change in frequency that occurs in this time.

Options :

34058019865. ✘ 51.66Hz

34058019866. ✘ 48.33Hz

34058019867. ✔ 50.83Hz

34058019868. ✘ 49.186Hz

Question Number : 48 Question Id : 3405804968 Question Type : MCQ Option Shuffling : Yes Display Question Number : Yes Is Question Mandatory : No Calculator : None Response Time : N.A Think Time : N.A Minimum Instruction Time : 0

Correct Marks : 1 Wrong Marks : 0

A 440 V, 3 phase distribution feeder has a load of 100kW at lagging p.f. with the load current of 200A. What is the new p.f after installing a shunt capacitor of 75KVar.

Options :

34058019869. ✘ 0.678

34058019870. ✘ 0.98

34058019871. ✘ 0.932

34058019872. ✓ 0.965

Question Number : 49 Question Id : 3405804969 Question Type : MCQ Option Shuffling : Yes Display Question Number : Yes Is Question Mandatory : No Calculator : None Response Time : N.A Think Time : N.A Minimum Instruction Time : 0

Correct Marks : 1 Wrong Marks : 0

The loop inductance per km of a single phase circuit comprising two parallel conductors 1 m apart and 1 cm in diameter is

Options :

34058019873. ✗ 2.22 kH/m

34058019874. ✓ 2.22 mH/km

34058019875. ✗ 2.22 H/km

34058019876. ✗ 2.22 mH/cm

Question Number : 50 Question Id : 3405804970 Question Type : MCQ Option Shuffling : Yes Display Question Number : Yes Is Question Mandatory : No Calculator : None Response Time : N.A Think Time : N.A Minimum Instruction Time : 0

Correct Marks : 1 Wrong Marks : 0

A single phase overhead line 32 km long consists of two parallel wires each 0.5cm diameter, 1.5 m apart. If the line voltage is 50KV at 50 Hz, the total charging current when the line is open circuit is

Options :

34058019877. ✗ 0.136 A

34058019878. ✖ 0.273 A

34058019879. ✖ 2.18 A

34058019880. ✔ 4.378 A

Question Number : 51 Question Id : 3405804971 Question Type : MCQ Option Shuffling : Yes Display Question Number : Yes Is Question Mandatory : No Calculator : None Response Time : N.A Think Time : N.A Minimum Instruction Time : 0

Correct Marks : 1 Wrong Marks : 0

A load of 15MW at 0.85 p.f. is delivered by a 3 phase transmission line having resistance of $0.905\Omega/\text{km}$. For the receiving end voltage to be 132 Kv and loss in transmission line is to be 7.5% of the load, the distance of the transmission line would be

Options :

34058019881. ✔ 69.56 km

34058019882. ✖ 56.56 km

34058019883. ✖ 45.56 km

34058019884. ✖ 77.18 km

Question Number : 52 Question Id : 3405804972 Question Type : MCQ Option Shuffling : Yes Display Question Number : Yes Is Question Mandatory : No Calculator : None Response Time : N.A Think Time : N.A Minimum Instruction Time : 0

Correct Marks : 1 Wrong Marks : 0

The sending end and receiving voltages of a 3 phase transmission line are maintained at 33 KV and 31.2 KV respectively. The resistance and reactance per phase are 20Ω and 50Ω respectively. The maximum power obtainable at the receiving end is

Options :

34058019885. ✘ 20.592 MW

34058019886. ✘ 9.12 MW

34058019887. ✔ 12.41 MW

34058019888. ✘ 42.41 MW

Question Number : 53 Question Id : 3405804973 Question Type : MCQ Option Shuffling : Yes Display Question Number : Yes Is Question Mandatory : No Calculator : None Response Time : N.A Think Time : N.A Minimum Instruction Time : 0

Correct Marks : 1 Wrong Marks : 0

A surge of 25 KV traveling in a line of surge impedance 500Ω arrives at a junction with two lines of impedance 700Ω and 200Ω respectively. The surge current transmitted into the line with surge impedance 700Ω is

Options :

34058019889. ✘ 59.32A

34058019890. ✔ 16.95A

34058019891. ✘ 76.26 A

34058019892. ✘ 11.06 A

Question Number : 54 Question Id : 3405804974 Question Type : MCQ Option Shuffling : Yes Display Question Number : Yes Is Question Mandatory : No Calculator : None Response Time : N.A Think Time : N.A Minimum Instruction Time : 0

Correct Marks : 1 Wrong Marks : 0

In a fault study problem, the following currents are measured

$I_R = 0$, $I_Y = 10A$, $I_B = -10A$. The zero sequence current is equal to.

Options :

34058019893. ✘ 5.773A

34058019894. ✘ 11.5A

34058019895. ✘ -5.773 A

34058019896. ✔ Zero A

Question Number : 55 Question Id : 3405804975 Question Type : MCQ Option Shuffling : Yes Display Question Number : Yes Is Question Mandatory : No Calculator : None Response Time : N.A Think Time : N.A Minimum Instruction Time : 0

Correct Marks : 1 Wrong Marks : 0

A 20 MVA, 6.6 KV star connected generator has positive, negative and zero sequence reactance's of 30%, 25% and 7% respectively. A reactor with 5% reactance based on the rating of the generator is placed in the neutral to ground connection. A line to line fault occurs at the terminals of the generator when it is operating at rated voltage. The fault current is

Options :

34058019897. ✔ -j 5509.32 A

34058019898. ✖ -j 1.818A

34058019899. ✖ -j 3180 A

34058019900. ✖ 444 A

Question Number : 56 Question Id : 3405804976 Question Type : MCQ Option Shuffling : Yes Display Question Number : Yes Is Question Mandatory : No Calculator : None Response Time : N.A Think Time : N.A Minimum Instruction Time : 0

Correct Marks : 1 Wrong Marks : 0

A generator rated 75 MVA is delivering 0.9 pu power to a motor through a transmission line of reactance $j 0.2$ p.u. The terminal voltage of the generator is 1.02 p.u and that of the motor is 1.0 p.u. The magnitude of the generator e.m.f behind transient reactance with $X'_d = 0.2$ is

Options :

34058019901. ✔ 1.07 p.u

34058019902. ✖ 1.04 p.u

34058019903. ✖ 1.02 p.u

34058019904. ✖ 1.0 p.u

Question Number : 57 Question Id : 3405804977 Question Type : MCQ Option Shuffling : Yes Display Question Number : Yes Is Question Mandatory : No Calculator : None Response Time : N.A Think Time : N.A Minimum Instruction Time : 0

Correct Marks : 1 Wrong Marks : 0

A transposed three phase 200 km long line delivers a power of 50 MVA at a power factor of 0.8 lagging, the receiving end voltage being 132 KV, at 50Hz. The line parameters per phase/km are: resistance=0.16 Ω , inductance 1.26mH, capacitance=8.77 x 10⁻⁹F. The sending voltage will be

Options :

34058019905. ✘ 93.96KV

34058019906. ✘ 160.54KV

34058019907. ✔ 157.56KV

34058019908. ✘ 132KV

Question Number : 58 Question Id : 3405804978 Question Type : MCQ Option Shuffling : Yes Display Question Number : Yes Is Question Mandatory : No Calculator : None Response Time : N.A Think Time : N.A Minimum Instruction Time : 0

Correct Marks : 1 Wrong Marks : 0

A power system consists of 300 buses out of which 20 buses are generator buses, 25 buses are the ones with reactive power support and 15 buses are the ones with fixed shunt capacitors. All the other buses are load buses. It is proposed to perform a load flow analysis for the system using Newton Raphson method. The size of the Newton-Raphson Jacobian matrix is

Options :

34058019909. ✘ 553 X 553

34058019910. ✔ 540 X 540

34058019911. ✘ 555 X 555

34058019912. ✖ 550 X 550

Question Number : 59 Question Id : 3405804979 Question Type : MCQ Option Shuffling : Yes Display Question Number : Yes Is Question Mandatory : No Calculator : None Response Time : N.A Think Time : N.A Minimum Instruction Time : 0

Correct Marks : 1 Wrong Marks : 0

A generator delivers power to an infinite bus via a transformer having reactance of $j0.25\text{p.u}$ and parallel transmission lines each having reactance of $j0.3\text{ p.u}$. Take $E_t = 1.2\angle 22.02^\circ\text{ pu}$, Infinite bus voltage $E = 1.0\angle 0^\circ\text{ pu}$ and $X_d'' = 0.3\text{pu}$. The power transferred when the system is healthy is

Options :

34058019913. ✖ 1.03p.u

34058019914. ✔ 0.6427p.u

34058019915. ✖ 0.5438p.u

34058019916. ✖ 0.998 p.u

Question Number : 60 Question Id : 3405804980 Question Type : MCQ Option Shuffling : Yes Display Question Number : Yes Is Question Mandatory : No Calculator : None Response Time : N.A Think Time : N.A Minimum Instruction Time : 0

Correct Marks : 1 Wrong Marks : 0

An example for closed loop system is

Options :

34058019917. ✔ Auto Pilot for an aircraft

34058019918. ✘ Direct current generator

34058019919. ✘ Car starter

34058019920. ✘ Electric Switch

**Question Number : 61 Question Id : 3405804981 Question Type : MCQ Option Shuffling : Yes
Display Question Number : Yes Is Question Mandatory : No Calculator : None Response Time
: N.A Think Time : N.A Minimum Instruction Time : 0**

Correct Marks : 1 Wrong Marks : 0

A closed loop system is different from open loop system by

Options :

34058019921. ✘ Input pattern

34058019922. ✘ Output pattern

34058019923. ✘ Input and output pattern

34058019924. ✔ Feedback

**Question Number : 62 Question Id : 3405804982 Question Type : MCQ Option Shuffling : Yes
Display Question Number : Yes Is Question Mandatory : No Calculator : None Response Time
: N.A Think Time : N.A Minimum Instruction Time : 0**

Correct Marks : 1 Wrong Marks : 0

A negative feedback amplifier employs a basic amplifier has open loop gain,
 $A = 200V/V$. The feedback factor is $0.1V/V$. The gain with negative feedback is

Options :

34058019925. ✖ 100

34058019926. ✔ 9.52

34058019927. ✖ 10

34058019928. ✖ 12.52

Question Number : 63 Question Id : 3405804983 Question Type : MCQ Option Shuffling : Yes Display Question Number : Yes Is Question Mandatory : No Calculator : None Response Time : N.A Think Time : N.A Minimum Instruction Time : 0

Correct Marks : 1 Wrong Marks : 0

The value of transfer function $G(s) = \frac{K(s+3)}{s(s+2)(s+4)}$ at $s=1$ is found to be 4. The value of K is

Options :

34058019929. ✖ 20

34058019930. ✔ 15

34058019931. ✖ 48

34058019932. ✖ 12

Question Number : 64 Question Id : 3405804984 Question Type : MCQ Option Shuffling : Yes Display Question Number : Yes Is Question Mandatory : No Calculator : None Response Time : N.A Think Time : N.A Minimum Instruction Time : 0

Correct Marks : 1 Wrong Marks : 0

The number of roots of $S^3+5S^2+7S + 3 =0$ in the left half of the s-plane is

Options :

34058019933. ✖ Zero

34058019934. ✖ One

34058019935. ✖ Two

34058019936. ✔ Three

**Question Number : 65 Question Id : 3405804985 Question Type : MCQ Option Shuffling : Yes
Display Question Number : Yes Is Question Mandatory : No Calculator : None Response Time
: N.A Think Time : N.A Minimum Instruction Time : 0**

Correct Marks : 1 Wrong Marks : 0

If the gain in a control system is increased

Options :

34058019937. ✖ The roots move away from the zeroes

34058019938. ✔ The roots move nearer to the zeroes

34058019939. ✖ The roots move nearer to the open-loop poles

34058019940. ✖ The position of the roots is not affected

**Question Number : 66 Question Id : 3405804986 Question Type : MCQ Option Shuffling : Yes
Display Question Number : Yes Is Question Mandatory : No Calculator : None Response Time
: N.A Think Time : N.A Minimum Instruction Time : 0**

Correct Marks : 1 Wrong Marks : 0

The point from which signal is taken for feedback purpose is called

Options :

34058019941. ✘ Summing point

34058019942. ✘ Null point

34058019943. ✔ Take-off point

34058019944. ✘ Feedback point

**Question Number : 67 Question Id : 3405804987 Question Type : MCQ Option Shuffling : Yes
Display Question Number : Yes Is Question Mandatory : No Calculator : None Response Time
: N.A Think Time : N.A Minimum Instruction Time : 0**

Correct Marks : 1 Wrong Marks : 0

In a signal flow graph representation, a loop consisting of a single branch and a single node is known as

Options :

34058019945. ✘ Non-touching loop

34058019946. ✔ Self-loop

34058019947. ✘ Touching loop

34058019948. ✘ Mixed loop

**Question Number : 68 Question Id : 3405804988 Question Type : MCQ Option Shuffling : Yes
Display Question Number : Yes Is Question Mandatory : No Calculator : None Response Time
: N.A Think Time : N.A Minimum Instruction Time : 0**

Correct Marks : 1 Wrong Marks : 0

Slope of asymptote in Bode plot for a second order system

Options :

34058019949. ✘ 10 dB/decade

34058019950. ✘ 20 dB/decade

34058019951. ✘ 30 dB/decade

34058019952. ✔ 40 dB/decade

Question Number : 69 Question Id : 3405804989 Question Type : MCQ Option Shuffling : Yes
Display Question Number : Yes Is Question Mandatory : No Calculator : None Response Time
: N.A Think Time : N.A Minimum Instruction Time : 0

Correct Marks : 1 Wrong Marks : 0

An op-amp based programmable gain amplifier with a negative feedback is designed.
Which is the best method to carryout stability analysis

Options :

34058019953. ✘ Nyquist Plot

34058019954. ✔ Bode Plot

34058019955. ✘ Root locus

34058019956. ✘ R-H stability criteria

Question Number : 70 Question Id : 3405804990 Question Type : MCQ Option Shuffling : Yes
Display Question Number : Yes Is Question Mandatory : No Calculator : None Response Time
: N.A Think Time : N.A Minimum Instruction Time : 0

Correct Marks : 1 Wrong Marks : 0

Positive feedback is avoided in amplifiers as it causes

Options :

34058019957. ✘ Stability

34058019958. ✔ Instability

34058019959. ✘ Reduces Gain

34058019960. ✘ Increases Gain

**Question Number : 71 Question Id : 3405804991 Question Type : MCQ Option Shuffling : Yes
Display Question Number : Yes Is Question Mandatory : No Calculator : None Response Time
: N.A Think Time : N.A Minimum Instruction Time : 0**

Correct Marks : 1 Wrong Marks : 0

In Gain margin calculations, the frequency at which the phase angle is 180° is called

Options :

34058019961. ✘ Break

34058019962. ✘ Critical

34058019963. ✔ Phase cross-over

34058019964. ✘ Cut-off

**Question Number : 72 Question Id : 3405804992 Question Type : MCQ Option Shuffling : Yes
Display Question Number : Yes Is Question Mandatory : No Calculator : None Response Time
: N.A Think Time : N.A Minimum Instruction Time : 0**

Correct Marks : 1 Wrong Marks : 0

Consider a characteristic equation given by $S^4 + 3S^3 + 5S^2 + 6S + K + 10$. The condition for stability is

Options :

34058019965. ✘ $K > 5$

34058019966. ✘ $-10 < K$

34058019967. ✘ $K > -4$

34058019968. ✔ $-10 < K < -4$

Question Number : 73 Question Id : 3405804993 Question Type : MCQ Option Shuffling : Yes Display Question Number : Yes Is Question Mandatory : No Calculator : None Response Time : N.A Think Time : N.A Minimum Instruction Time : 0

Correct Marks : 1 Wrong Marks : 0

A second order system has a transfer function is given by $G(s) = \frac{100}{s^2 + 16s + 100}$. If the system is initially at rest is subjected to a unit step function input at $t = 0$, the second peak in the response will occur at

Options :

34058019969. ✘ π sec

34058019970. ✘ $\pi/3$ sec

34058019971. ✘ $2\pi/3$ sec

34058019972. ✔ $\pi/2$ sec

Question Number : 74 Question Id : 3405804994 Question Type : MCQ Option Shuffling : Yes
Display Question Number : Yes Is Question Mandatory : No Calculator : None Response Time
: N.A Think Time : N.A Minimum Instruction Time : 0

Correct Marks : 1 Wrong Marks : 0

The capacitance, in force-current analogy, is analogous to

Options :

34058019973. ✖ Momentum

34058019974. ✖ Velocity

34058019975. ✔ Mass

34058019976. ✖ Displacement

Question Number : 75 Question Id : 3405804995 Question Type : MCQ Option Shuffling : Yes
Display Question Number : Yes Is Question Mandatory : No Calculator : None Response Time
: N.A Think Time : N.A Minimum Instruction Time : 0

Correct Marks : 1 Wrong Marks : 0

An amplifier with single pole is

Options :

34058019977. ✖ Unstable

34058019978. ✖ Cannot predict stability

34058019979. ✔ Stable

34058019980. ✖ Oscillatory

Question Number : 76 Question Id : 3405804996 Question Type : MCQ Option Shuffling : Yes
Display Question Number : Yes Is Question Mandatory : No Calculator : None Response Time
: N.A Think Time : N.A Minimum Instruction Time : 0

Correct Marks : 1 Wrong Marks : 0

The transfer function of the system is $G(s) = \frac{100}{(s+1)(s+100)}$. For unit-step input to the system the approximate settling time for 5% criterion is

Options :

34058019981. ✘ 100 sec

34058019982. ✘ 40 sec

34058019983. ✔ 3 sec

34058019984. ✘ 0.01 sec

Question Number : 77 Question Id : 3405804997 Question Type : MCQ Option Shuffling : Yes
Display Question Number : Yes Is Question Mandatory : No Calculator : None Response Time
: N.A Think Time : N.A Minimum Instruction Time : 0

Correct Marks : 1 Wrong Marks : 0

The voltage drop across a moving iron type ammeter is 0.1 V when a current of 5A at 50Hz is being measured. If the current is 5A dc, the drop across the meter will

Options :

34058019985. ✘ Increase

34058019986. ✔ Decrease

34058019987. ✘ Remain the same

34058019988. ✘ Be doubled

Question Number : 78 Question Id : 3405804998 Question Type : MCQ Option Shuffling : Yes Display Question Number : Yes Is Question Mandatory : No Calculator : None Response Time : N.A Think Time : N.A Minimum Instruction Time : 0

Correct Marks : 1 Wrong Marks : 0

An energy meter having a meter constant of 1200 revolutions per kWh makes 5 revolutions in 75 seconds. The load power is

Options :

34058019989. ✘ 5 kW

34058019990. ✔ 200 W

34058019991. ✘ 2 kW

34058019992. ✘ 288 kW

Question Number : 79 Question Id : 3405804999 Question Type : MCQ Option Shuffling : Yes Display Question Number : Yes Is Question Mandatory : No Calculator : None Response Time : N.A Think Time : N.A Minimum Instruction Time : 0

Correct Marks : 1 Wrong Marks : 0

For measuring very high resistance, the following is used

Options :

34058019993. ✘ Wheatstone bridge

34058019994. ✔ Megger

34058019995. ✘ Kelvin's Double bridge

34058019996. ✖ Anderson bridge

Question Number : 80 Question Id : 3405805000 Question Type : MCQ Option Shuffling : Yes Display Question Number : Yes Is Question Mandatory : No Calculator : None Response Time : N.A Think Time : N.A Minimum Instruction Time : 0

Correct Marks : 1 Wrong Marks : 0

A voltmeter has an internal resistance of $2\text{ k}\Omega$, and it can measure upto 5V . If 25V needs to be measured, then how much series resistance (in $\text{k}\Omega$) needs to be added

Options :

34058019997. ✔ 8

34058019998. ✖ 10

34058019999. ✖ 2

34058020000. ✖ 0.8

Question Number : 81 Question Id : 3405805001 Question Type : MCQ Option Shuffling : Yes Display Question Number : Yes Is Question Mandatory : No Calculator : None Response Time : N.A Think Time : N.A Minimum Instruction Time : 0

Correct Marks : 1 Wrong Marks : 0

If current in the fixed coil and the moving coil of an electrodynamic instrument are 5 mA and 4 mA respectively, then 60° deflection is produced. If we connect the fixed and moving coil in series and pass 3 mA current through them, then what will be the deflection

Options :

34058020001. ✔ 27°

34058020002. ✘ 133°

34058020003. ✘ 9°

34058020004. ✘ 4.18°

Question Number : 82 Question Id : 3405805002 Question Type : MCQ Option Shuffling : Yes
Display Question Number : Yes Is Question Mandatory : No Calculator : None Response Time
: N.A Think Time : N.A Minimum Instruction Time : 0

Correct Marks : 1 Wrong Marks : 0

In the figure, open circuit voltage between A and B is $V_{AB} = 10$ V. The Thevenin resistance between A and B is 250Ω . If we measure the voltage V_{AB} with a voltmeter having internal resistance of $1 \text{ k}\Omega$, how much error will occur as a percentage of the true voltage V_{AB} (in the absence of the meter)

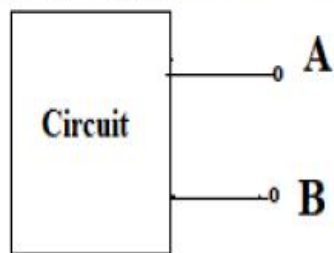

Options :

34058020005. ✘ 10 %

34058020006. ✘ 1 %

34058020007. ✔ 20 %

34058020008. ✘ Zero error

Question Number : 83 Question Id : 3405805003 Question Type : MCQ Option Shuffling : Yes
Display Question Number : Yes Is Question Mandatory : No Calculator : None Response Time

: N.A Think Time : N.A Minimum Instruction Time : 0

Correct Marks : 1 Wrong Marks : 0

A battery has a high internal resistance. Its EMF is found to be 0.8 V with a potentiometer. The actual EMF is

Options :

34058020009. ✘ Greater than 0.8 v

34058020010. ✔ Equal to 0.8 v

34058020011. ✘ Less than 0.8 V

34058020012. ✘ Zero

Question Number : 84 Question Id : 3405805004 Question Type : MCQ Option Shuffling : Yes
Display Question Number : Yes Is Question Mandatory : No Calculator : None Response Time
: N.A Think Time : N.A Minimum Instruction Time : 0

Correct Marks : 1 Wrong Marks : 0

Wagner's earth devices are used in ac bridge circuits for

Options :

34058020013. ✘ Eliminating the effect of stray electrostatic fields

34058020014. ✘ Shielding the bridge elements

34058020015. ✘ Eliminating the effect of inter component capacitances

34058020016. ✔ Eliminating the effect of earth capacitances

Question Number : 85 Question Id : 3405805005 Question Type : MCQ Option Shuffling : Yes
Display Question Number : Yes Is Question Mandatory : No Calculator : None Response Time
: N.A Think Time : N.A Minimum Instruction Time : 0

Correct Marks : 1 Wrong Marks : 0

To measure an AC current which can go up to 1 kA, an ammeter of range 0 to 10 A and internal resistance $10\ \Omega$ is available. By using a suitable Current Transformer (CT) the range of ammeter is changed. How much power (in W) will be consumed by our CT and ammeter arrangement while measuring 1 kA current? Assume the CT to be ideal.

Options :

34058020017. ✘ Zero

34058020018. ✔ 1000 W

34058020019. ✘ 3.100 W

34058020020. ✘ 4.10 W

Question Number : 86 Question Id : 3405805006 Question Type : MCQ Option Shuffling : Yes
Display Question Number : Yes Is Question Mandatory : No Calculator : None Response Time
: N.A Think Time : N.A Minimum Instruction Time : 0

Correct Marks : 1 Wrong Marks : 0

Two sine waves of different frequencies are connected to a two-channel oscilloscope and the frequency of the signal applied to the X axis is 60 Hz. If the display in X – Y mode looks like the figure below, what is the frequency (in Hz) of the signal applied to the Y axis

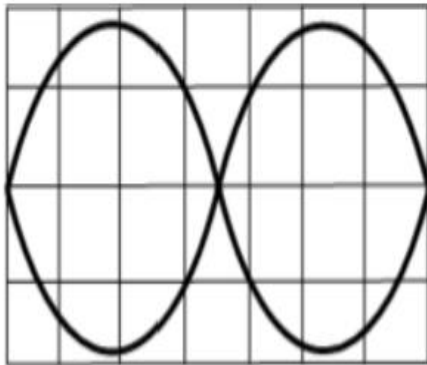

Options :

34058020021. ✘ 30 Hz

34058020022. ✘ 60 Hz

34058020023. ✘ 90 Hz

34058020024. ✔ 120 Hz

Question Number : 87 Question Id : 3405805007 Question Type : MCQ Option Shuffling : Yes Display Question Number : Yes Is Question Mandatory : No Calculator : None Response Time : N.A Think Time : N.A Minimum Instruction Time : 0

Correct Marks : 1 Wrong Marks : 0

In an oscilloscope, when the unknown signal applied to the vertical plates is synchronized with the sweep signal applied to the horizontal plates, the pattern seen on the CRO screen moves towards the right. It means that,

Options :

The frequency of the unknown signal is equal to the frequency of the sweep

34058020025. ✘ signal

34058020026. ✘ The frequency of the unknown signal is larger than the frequency of the sweep signal

34058020027. ✔ The frequency of the unknown signal is smaller than the frequency of the sweep signal

34058020028. ✘ The frequency of the unknown signal is twice that of the frequency of the sweep signal

Question Number : 88 Question Id : 3405805008 Question Type : MCQ Option Shuffling : Yes Display Question Number : Yes Is Question Mandatory : No Calculator : None Response Time : N.A Think Time : N.A Minimum Instruction Time : 0

Correct Marks : 1 Wrong Marks : 0

A three phase 500 V motor load has a power factor of 0.866. Two wattmeters are connected to measure the input which is 30 kW. Find the reading of each wattmeter

Options :

34058020029. ✘ 60kW, -30kW

34058020030. ✘ 40kW, -10 kW

34058020031. ✘ 10kW, 30kW

34058020032. ✔ 20kW, 10 kW

Question Number : 89 Question Id : 3405805009 Question Type : MCQ Option Shuffling : Yes Display Question Number : Yes Is Question Mandatory : No Calculator : None Response Time : N.A Think Time : N.A Minimum Instruction Time : 0

Correct Marks : 1 Wrong Marks : 0

For dual slope ADC type $3\frac{1}{2}$ digit DVM, the reference voltage is 100 mV and the first integration is set to 300 ms. For some input voltage, the de-integration period is 390 ms. The DVM will indicate

Options :

34058020033. ✘ 77 mV

34058020034. ✘ 13 mV

34058020035. ✔ 130 mV

34058020036. ✘ 7.7 mV

Question Number : 90 Question Id : 3405805010 Question Type : MCQ Option Shuffling : Yes Display Question Number : Yes Is Question Mandatory : No Calculator : None Response Time : N.A Think Time : N.A Minimum Instruction Time : 0

Correct Marks : 1 Wrong Marks : 0

A wattmeter is connected as shown in the figure. The wattmeter reads

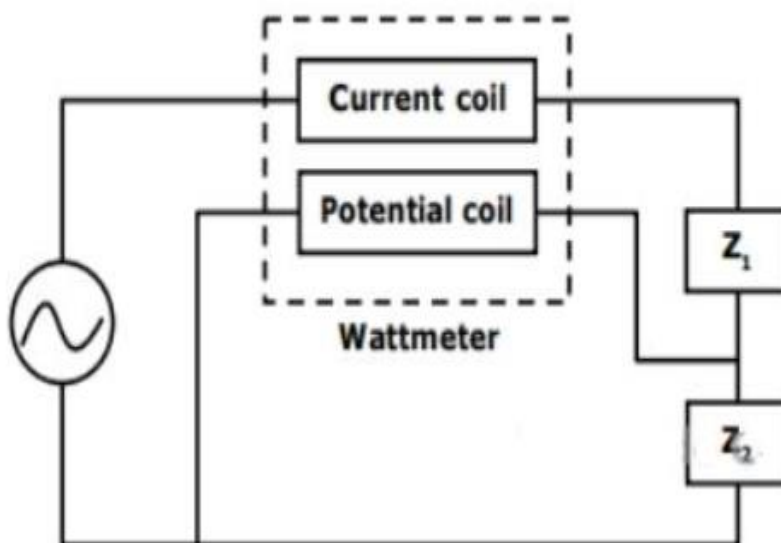

Options :

34058020037. ✘ Zero

34058020038. ✖ Total power consumed by Z_1 and Z_2

34058020039. ✖ Power consumed by Z_1 only

34058020040. ✔ Power consumed by Z_2 only

Question Number : 91 Question Id : 3405805011 Question Type : MCQ Option Shuffling : Yes Display Question Number : Yes Is Question Mandatory : No Calculator : None Response Time : N.A Think Time : N.A Minimum Instruction Time : 0

Correct Marks : 1 Wrong Marks : 0

A current transformer has a rating of 100/5 A. Its magnetizing and loss components are 1 A and 0.6 A respectively and secondary winding burden is purely resistive, the transformation ratio at rated current is

Options :

34058020041. ✔ 20.12 A

34058020042. ✖ 20.2 A

34058020043. ✖ 20 A

34058020044. ✖ 20.6 A

Question Number : 92 Question Id : 3405805012 Question Type : MCQ Option Shuffling : Yes Display Question Number : Yes Is Question Mandatory : No Calculator : None Response Time : N.A Think Time : N.A Minimum Instruction Time : 0

Correct Marks : 1 Wrong Marks : 0

A dc voltmeter has a sensitivity of $1000\Omega/\text{volt}$. When it measures half full scale in 100 V range, the current through the voltmeter is

Options :

34058020045. ✘ 50 mA

34058020046. ✘ 100 mA

34058020047. ✘ 1 mA

34058020048. ✔ 0.5 mA

Question Number : 93 Question Id : 3405805013 Question Type : MCQ Option Shuffling : Yes Display Question Number : Yes Is Question Mandatory : No Calculator : None Response Time : N.A Think Time : N.A Minimum Instruction Time : 0

Correct Marks : 1 Wrong Marks : 0

The following measurements are obtained on a single-phase load: $V = 220V \pm 1\%$, $I = 5.0 A \pm 1\%$ and $W = 555 W \pm 2\%$. If the power factor is calculated using these measurements, the worst-case error in the calculated power factor in percent is

Options :

34058020049. ✘ $\pm 2 \%$

34058020050. ✔ $\pm 4 \%$

34058020051. ✘ $\pm 1 \%$

34058020052. ✘ $\pm 0.5 \%$

Question Number : 94 Question Id : 3405805014 Question Type : MCQ Option Shuffling : Yes Display Question Number : Yes Is Question Mandatory : No Calculator : None Response Time : N.A Think Time : N.A Minimum Instruction Time : 0

Correct Marks : 1 Wrong Marks : 0

The number of rows in the truth table of N variables

Options :

34058020053. ✘ N

34058020054. ✘ $2N$

34058020055. ✔ 2^N

34058020056. ✘ 2^{2N}

Question Number : 95 Question Id : 3405805015 Question Type : MCQ Option Shuffling : Yes
Display Question Number : Yes Is Question Mandatory : No Calculator : None Response Time
: N.A Think Time : N.A Minimum Instruction Time : 0

Correct Marks : 1 Wrong Marks : 0

A staircase light is controlled by two switches, one at the top of the stairs and another at the bottom of the stairs. The logic gate that realizes this functionality is

Options :

34058020057. ✘ AND

34058020058. ✘ NAND

34058020059. ✔ X-OR

34058020060. ✘ OR

Question Number : 96 Question Id : 3405805016 Question Type : MCQ Option Shuffling : Yes
Display Question Number : Yes Is Question Mandatory : No Calculator : None Response Time
: N.A Think Time : N.A Minimum Instruction Time : 0

Correct Marks : 1 Wrong Marks : 0

Minterms corresponding to decimal number 15 is

Options :

34058020061. ✓ ABCD

34058020062. ✗ $A\bar{B}CD$

34058020063. ✗ $AB\bar{C}\bar{D}$

34058020064. ✗ $\bar{A}\bar{B}\bar{C}\bar{D}$

**Question Number : 97 Question Id : 3405805017 Question Type : MCQ Option Shuffling : Yes
Display Question Number : Yes Is Question Mandatory : No Calculator : None Response Time
: N.A Think Time : N.A Minimum Instruction Time : 0**

Correct Marks : 1 Wrong Marks : 0

The output of logic gate is '1' when odd numbers of inputs are high. The gate is

Options :

34058020065. ✗ NOR

34058020066. ✗ XNOR

34058020067. ✗ AND

34058020068. ✓ X-OR

**Question Number : 98 Question Id : 3405805018 Question Type : MCQ Option Shuffling : Yes
Display Question Number : Yes Is Question Mandatory : No Calculator : None Response Time
: N.A Think Time : N.A Minimum Instruction Time : 0**

Correct Marks : 1 Wrong Marks : 0

The address bus width of the memory of size 2048×8 bits is

Options :

34058020069. ✘ 10-bits

34058020070. ✔ 11- bits

34058020071. ✘ 12-bits

34058020072. ✘ 20-bits

**Question Number : 99 Question Id : 3405805019 Question Type : MCQ Option Shuffling : Yes
Display Question Number : Yes Is Question Mandatory : No Calculator : None Response Time
: N.A Think Time : N.A Minimum Instruction Time : 0**

Correct Marks : 1 Wrong Marks : 0

The highest priority interrupt in 8085 is

Options :

34058020073. ✔ TRAP

34058020074. ✘ RST 6.5

34058020075. ✘ INTR

34058020076. ✘ RST 7.5

**Question Number : 100 Question Id : 3405805020 Question Type : MCQ Option Shuffling : Yes
Display Question Number : Yes Is Question Mandatory : No Calculator : None Response Time
: N.A Think Time : N.A Minimum Instruction Time : 0**

Correct Marks : 1 Wrong Marks : 0

In an 8085 microprocessor, which one of the following instructions changes the contents of the accumulator

Options :

34058020077. ✘ MOV B, M

34058020078. ✘ PCHL

34058020079. ✘ RNZ

34058020080. ✔ SBI BEH

Question Number : 101 Question Id : 3405805021 Question Type : MCQ Option Shuffling : Yes

Display Question Number : Yes Is Question Mandatory : No Calculator : None Response Time

: N.A Think Time : N.A Minimum Instruction Time : 0

Correct Marks : 1 Wrong Marks : 0

Consider the multiplexer base logic circuit shown in the below figure. The value of G is

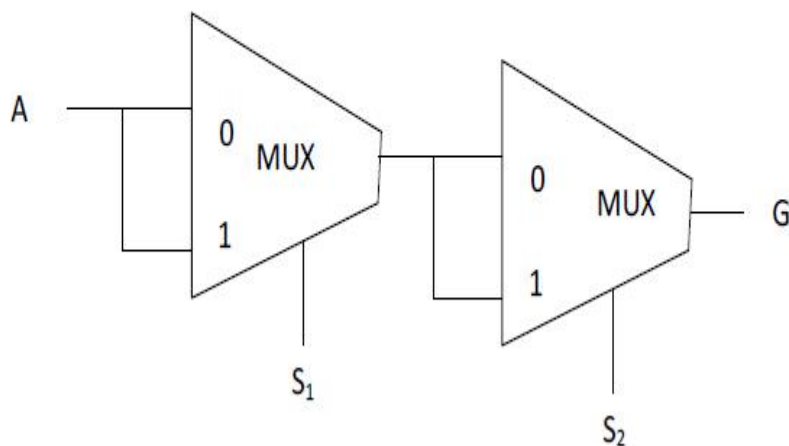

Options :

34058020081. ✘ $S_1 + A$

34058020082. ✘ $S_2 + S_1 \bar{A}$

34058020083. ✓ A

34058020084. ✗ $S_1 + S_1 \bar{A}$

Question Number : 102 Question Id : 3405805022 Question Type : MCQ Option Shuffling : Yes
Display Question Number : Yes Is Question Mandatory : No Calculator : None Response Time
: N.A Think Time : N.A Minimum Instruction Time : 0

Correct Marks : 1 Wrong Marks : 0

Minimum number of D-latches required to design one flip-flop

Options :

34058020085. ✓ Two

34058020086. ✗ One

34058020087. ✗ Three

34058020088. ✗ Four

Question Number : 103 Question Id : 3405805023 Question Type : MCQ Option Shuffling : Yes
Display Question Number : Yes Is Question Mandatory : No Calculator : None Response Time
: N.A Think Time : N.A Minimum Instruction Time : 0

Correct Marks : 1 Wrong Marks : 0

Each cell of static random access memory contains

Options :

34058020089. ✗ 1 MOS transistor and 1 capacitor

34058020090. ✗ 2 MOS transistors and 2 capacitors

34058020091. ✓ 6 MOS transistors

34058020092. ✗ 4 MOS transistors and 4 capacitors

Question Number : 104 Question Id : 3405805024 Question Type : MCQ Option Shuffling : Yes
Display Question Number : Yes Is Question Mandatory : No Calculator : None Response Time
: N.A Think Time : N.A Minimum Instruction Time : 0

Correct Marks : 1 Wrong Marks : 0

A non-inverting op-amp circuit shown in the below figure provides a gain of 5.5.
Assume you have resistor $R_i = 10\text{k}\Omega$. The value of feedback resistor R_f is

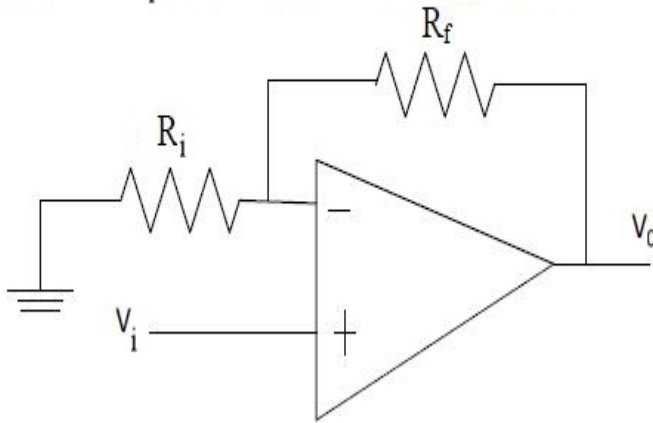

Options :

34058020093. ✗ 4.5 K Ω

34058020094. ✓ 45 K Ω

34058020095. ✗ 55 K Ω

34058020096. ✗ 1 K Ω

Question Number : 105 Question Id : 3405805025 Question Type : MCQ Option Shuffling : Yes
Display Question Number : Yes Is Question Mandatory : No Calculator : None Response Time

: N.A Think Time : N.A Minimum Instruction Time : 0

Correct Marks : 1 Wrong Marks : 0

Rotating the binary bits to one position to the left and filling the LSB by zero is equivalent to

Options :

34058020097. ✓ Multiplying by 2

34058020098. ✗ Dividing by 2

34058020099. ✗ Multiplying by 4

34058020100. ✗ Dividing by 4

Question Number : 106 Question Id : 3405805026 Question Type : MCQ Option Shuffling : Yes

Display Question Number : Yes Is Question Mandatory : No Calculator : None Response Time

: N.A Think Time : N.A Minimum Instruction Time : 0

Correct Marks : 1 Wrong Marks : 0

A DRAM cell consists of

Options :

34058020101. ✗ 6 transistors

34058020102. ✗ 2 transistors and 2 capacitors

34058020103. ✗ 6 MOS transistors

34058020104. ✓ 1 transistor and 1 capacitor

Question Number : 107 Question Id : 3405805027 Question Type : MCQ Option Shuffling : Yes
Display Question Number : Yes Is Question Mandatory : No Calculator : None Response Time
: N.A Think Time : N.A Minimum Instruction Time : 0

Correct Marks : 1 Wrong Marks : 0

The CMRR in an ideal OPAMP circuit is

Options :

34058020105. ✘ Zero

34058020106. ✔ Infinity

34058020107. ✘ Depends on Gain

34058020108. ✘ One

Question Number : 108 Question Id : 3405805028 Question Type : MCQ Option Shuffling : Yes
Display Question Number : Yes Is Question Mandatory : No Calculator : None Response Time
: N.A Think Time : N.A Minimum Instruction Time : 0

Correct Marks : 1 Wrong Marks : 0

The following element is used to reduce ripple in a rectifier circuit

Options :

34058020109. ✘ Resistor

34058020110. ✘ Diode

34058020111. ✔ Capacitor

34058020112. ✘ Zener Diode

Question Number : 109 Question Id : 3405805029 Question Type : MCQ Option Shuffling : Yes
Display Question Number : Yes Is Question Mandatory : No Calculator : None Response Time
: N.A Think Time : N.A Minimum Instruction Time : 0

Correct Marks : 1 Wrong Marks : 0

The part of the computer used for calculating and comparing

Options :

34058020113. ✘ Control Unit

34058020114. ✘ Modem

34058020115. ✔ ALU

34058020116. ✘ Disk Unit

Question Number : 110 Question Id : 3405805030 Question Type : MCQ Option Shuffling : Yes
Display Question Number : Yes Is Question Mandatory : No Calculator : None Response Time
: N.A Think Time : N.A Minimum Instruction Time : 0

Correct Marks : 1 Wrong Marks : 0

The manufacturer of a selected diode gives the rate of fall of the diode current is $20 \text{ A}/\mu\text{s}$,
and a reverse recovery time is $5 \mu\text{s}$. What is the value of stored charge

Options :

34058020117. ✔ $250 \mu\text{C}$

34058020118. ✘ $500 \mu\text{C}$

34058020119. ✘ $50 \mu\text{C}$

34058020120. ✘ $10 \mu\text{C}$

Question Number : 111 Question Id : 3405805031 Question Type : MCQ Option Shuffling : Yes
Display Question Number : Yes Is Question Mandatory : No Calculator : None Response Time
: N.A Think Time : N.A Minimum Instruction Time : 0

Correct Marks : 1 Wrong Marks : 0

The switch is closed, when the Triac is fired. Calculate the current through $62\ \Omega$ resistor when Triac has a drop of 1V

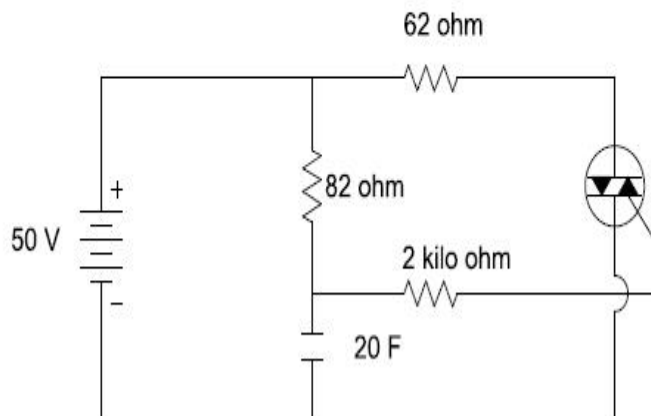

Options :

34058020121. ✘ 0.98 A

34058020122. ✔ 0.79 A

34058020123. ✘ 0.86 A

34058020124. ✘ 0.64 A

Question Number : 112 Question Id : 3405805032 Question Type : MCQ Option Shuffling : Yes
Display Question Number : Yes Is Question Mandatory : No Calculator : None Response Time
: N.A Think Time : N.A Minimum Instruction Time : 0

Correct Marks : 1 Wrong Marks : 0

The IGBT used in a circuit has the following data: $T_{on} = 3 \mu s$, $T_{off} = 1.2 \mu s$, Duty cycle = 0.7, $V_{ce} (sat) = 2 V$, $F_s = 2 kHz$. Find switching power loss during turn on. Assume $V_{ce} = 100 V$ and $R_L = 100 \Omega$

Options :

34058020125. ✘ 0.078 W

34058020126. ✘ 0.088 W

34058020127. ✔ 0.098 W

34058020128. ✘ 0.068 W

Question Number : 113 Question Id : 3405805033 Question Type : MCQ Option Shuffling : Yes Display Question Number : Yes Is Question Mandatory : No Calculator : None Response Time : N.A Think Time : N.A Minimum Instruction Time : 0

Correct Marks : 1 Wrong Marks : 0

When a reverse gate voltage of 10 V is applied to a MOSFET, the gate current is $10^{-3} \mu A$. Find the resistance between gate and source

Options :

34058020129. ✘ 10000 k Ω

34058020130. ✘ 1000 k Ω

34058020131. ✔ 10000 M Ω

34058020132. ✘ 1000 M Ω

Question Number : 114 Question Id : 3405805034 Question Type : MCQ Option Shuffling : Yes

Display Question Number : Yes Is Question Mandatory : No Calculator : None Response Time : N.A Think Time : N.A Minimum Instruction Time : 0

Correct Marks : 1 Wrong Marks : 0

Capacitors in RC triggering circuits usually fall in the range from

Options :

34058020133. ✓ 0.01 μF to 1 μF

34058020134. ✗ 0.1 μF to 1 μF

34058020135. ✗ 0.001 μF to 0.1 μF

34058020136. ✗ 0.01 μF to 0.1 μF

Question Number : 115 Question Id : 3405805035 Question Type : MCQ Option Shuffling : Yes Display Question Number : Yes Is Question Mandatory : No Calculator : None Response Time : N.A Think Time : N.A Minimum Instruction Time : 0

Correct Marks : 1 Wrong Marks : 0

A power supply 'A' delivers 10 V dc with a ripple of 0.5 V r.m.s. while the power supply 'B' delivers 10 V dc with a ripple of 0.7 V r.m.s. The ripple factor of power supplies 'A' and 'B' respectively are

Options :

34058020137. ✗ 4 %, 5 %

34058020138. ✗ 5 %, 6 %

34058020139. ✓ 5 %, 7 %

34058020140. ✗ 4 %, 7 %

Question Number : 116 Question Id : 3405805036 Question Type : MCQ Option Shuffling : Yes Display Question Number : Yes Is Question Mandatory : No Calculator : None Response Time : N.A Think Time : N.A Minimum Instruction Time : 0

Correct Marks : 1 Wrong Marks : 0

A single-phase fully-controlled bridge converter supplies power to a highly-inductive load with resistance $R = 10 \Omega$ from a 240 V rms 50 Hz AC source. Displacement factor is 0.8 and Distortion factor is 0.9. Calculate input power factor

Options :

34058020141. ✘ 0.62

34058020142. ✘ 1.7

34058020143. ✘ 0.1

34058020144. ✔ 0.72

Question Number : 117 Question Id : 3405805037 Question Type : MCQ Option Shuffling : Yes Display Question Number : Yes Is Question Mandatory : No Calculator : None Response Time : N.A Think Time : N.A Minimum Instruction Time : 0

Correct Marks : 1 Wrong Marks : 0

A single phase half wave-controlled rectifier has $400 \sin(314t)$ as the input voltage and R load. For the firing angle of 60° of SCR. The average output voltage is

Options :

34058020145. ✘ $240/\pi$ Volt

34058020146. ✘ $400/\pi$ Volt

34058020147. ✔ $300/\pi$ Volt

34058020148. ✘ $200/\pi$ Volt

Question Number : 118 Question Id : 3405805038 Question Type : MCQ Option Shuffling : Yes
Display Question Number : Yes Is Question Mandatory : No Calculator : None Response Time
: N.A Think Time : N.A Minimum Instruction Time : 0
Correct Marks : 1 Wrong Marks : 0

The step-down chopper shown below is operated at the switching frequency $f_s = 10$ kHz. Find the duty ratio k so that the average load current $I_a = 2$ A.

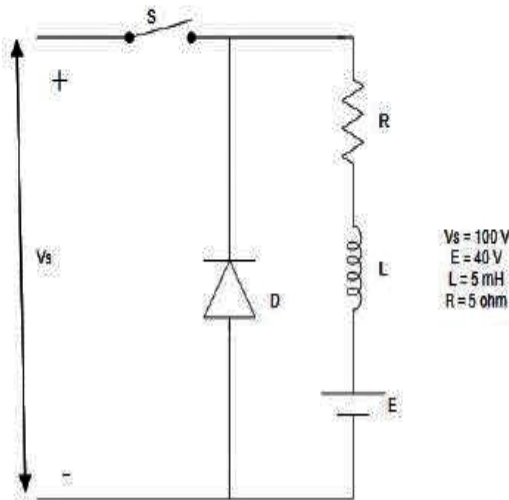

Options :

34058020149. ✔ 0.5

34058020150. ✘ 0.6

34058020151. ✘ 0.7

34058020152. ✘ 0.4

Question Number : 119 Question Id : 3405805039 Question Type : MCQ Option Shuffling : Yes

Display Question Number : Yes Is Question Mandatory : No Calculator : None Response Time : N.A Think Time : N.A Minimum Instruction Time : 0

Correct Marks : 1 Wrong Marks : 0

A single-phase inverter has a supply voltage of 100V dc, supplying a resistive load with $R=10\ \Omega$ with a center-tap transformer of 1:1 ratio. The output frequency is 50 Hz. The rms output voltage is 10 V and fundamental output voltage is 5 V. The total harmonic distortion in percentage is _____

Options :

34058020153. ✓ 173.2%

34058020154. ✗ 223.2%

34058020155. ✗ 273.2%

34058020156. ✗ 866.02%

Question Number : 120 Question Id : 3405805040 Question Type : MCQ Option Shuffling : Yes Display Question Number : Yes Is Question Mandatory : No Calculator : None Response Time : N.A Think Time : N.A Minimum Instruction Time : 0

Correct Marks : 1 Wrong Marks : 0

In the 180° conduction mode of a three-phase inverter, SCR triggering occurs at intervals of

Options :

34058020157. ✗ 120°

34058020158. ✗ 180°

34058020159. ✗ 240°

34058020160. ✓ 60°

