

# COMEDK 2023 Morning Shift

## Mathematics

### Question 1

The value of  $a^{\log_b c} - c^{\log_b a}$ , where  $a, b, c > 0$  but  $a, b, c \neq 1$ , is

Options:

A. a

B. b

C. c

D. 0

Answer: D

Solution:

$$\begin{aligned} \text{Let } y &= C^{\log_b a} \\ \Rightarrow \log_C y &= \log_b a \\ \Rightarrow \frac{\log y}{\log c} &= \frac{\log a}{\log b} \quad \left[ \because \log_a b = \frac{\log b}{\log a} \right] \\ \Rightarrow \frac{\log y}{\log a} &= \frac{\log c}{\log b} \Rightarrow \log_a y = \log_b c \\ \Rightarrow y &= a^{\log_b c} \quad \left[ \because \log_a x = y \Rightarrow a^y = x \right] \\ \therefore a^{\log_b c} - c^{\log_b a} &= a^{\log_b c} - a^{\log_b c} \\ &= 0 \end{aligned}$$

---

### Question 2

The slope of the tangent to the curve,  $y = x^2 - xy$  at  $(1, \frac{1}{2})$  is

Options:

A.  $\frac{4}{3}$

B.  $\frac{2}{3}$

C.  $\frac{3}{4}$

D.  $\frac{3}{2}$

**Answer: C**

**Solution:**

Given curve,  $y = x^2 - xy$ .

On differentiating the equation,  $y = x^2 - xy$  w.r.t.  $x$ , we

$$\begin{aligned} \text{get } \frac{dy}{dx} &= 2x - \left( x \frac{dy}{dx} + y \right) \\ \Rightarrow (1+x) \frac{dy}{dx} &= 2x - y \Rightarrow \frac{dy}{dx} = \frac{2x - y}{1+x} \\ \Rightarrow \left( \frac{dy}{dx} \right)_{(1,1/2)} &= \frac{2(1) - \left(\frac{1}{2}\right)}{1+(1)} = \frac{3/2}{2} = \frac{3}{4} \end{aligned}$$

---

### Question 3

The value of  $\lim_{x \rightarrow 0} \frac{e^{ax} - e^{bx}}{2x}$  is equal to

**Options:**

A.  $\frac{a+b}{2}$

B.  $\frac{a-b}{2}$

C.  $\frac{e^{ab}}{2}$

D. 0

**Answer: B**

**Solution:**

$$\begin{aligned}
& \lim_{x \rightarrow 0} \frac{e^{ax} - e^{bx}}{2x} \\
& \left( 1 + ax + \frac{(ax)^2}{2!} + \frac{(ax)^3}{3!} + \dots \right) \\
& - \left( 1 + bx + \frac{(bx)^2}{2!} + \frac{(bx)^3}{3!} + \dots \right) \\
& = \lim_{x \rightarrow 0} \frac{2x \left[ (a-b) + \left( \frac{a^2x}{2!} + \frac{a^3x^2}{3!} + \dots \right) \right]}{2x} \\
& = \lim_{x \rightarrow 0} \frac{x \left[ (a-b) + \left( \frac{a^2x}{2!} + \frac{a^3x^2}{3!} + \dots \right) \right]}{2x} \\
& = \frac{1}{2} [(a-b) + (0+0+\dots) + (0+0+\dots)] \\
& = \frac{a-b}{2}
\end{aligned}$$

---

## Question 4

The points of intersection of circles  $(x + 1)^2 + y^2 = 4$  and  $(x - 1)^2 + y^2 = 9$  are  $(a, \pm b)$ , then  $(a, b)$  equals to

Options:

- A.  $\left(1.25, \frac{3}{4}\sqrt{7}\right)$
- B.  $\left(-1.25, \frac{3}{4}\sqrt{7}\right)$
- C.  $(-1, 2)$
- D.  $(1, 3)$

**Answer: B**

**Solution:**

Given,  $(x + 1)^2 + y^2 = 4$  ... (i)

and  $(x - 1)^2 + y^2 = 9$  ... (ii)

On subtracting Eq. (ii) from Eq. (i), we get

$$(x + 1)^2 - (x - 1)^2 = 4 - 9$$

$$\Rightarrow (x^2 + 2x + 1) - (x^2 - 2x + 1) = -5$$

$$\Rightarrow 4x = -5$$

$$\Rightarrow x = -1.25$$

On putting,  $x = -1.25$  into Eq. (i), we get

$$(-0.25)^2 + y^2 = 4$$

$$\Rightarrow y^2 = 3.9375 \Rightarrow y = \pm\sqrt{3.9375}$$

$$\Rightarrow y = \pm\frac{3}{4}\sqrt{7}$$

$$\therefore a = -1.25 \text{ and } b = \frac{3}{4}\sqrt{7}$$

$$\therefore (a, b) = \left(-1.25, \frac{3}{4}\sqrt{7}\right)$$

---

## Question 5

The approximate value of  $f(5.001)$ , where  $f(x) = x^3 - 7x^2 + 10$

Options:

A.  $-39.995$

B.  $-38.995$

C.  $-37.335$

D.  $-40.995$

**Answer: A**

**Solution:**

First, break the number 5.001 as  $x = 5$  and  $\Delta x = 0.001$  and use the relation

$$f(x + \Delta x) \approx f(x) + \Delta x f'(x)$$

$$\text{consider } f(x) = x^3 - 7x^2 + 10 \Rightarrow f'(x) = 3x^2 - 14x$$

Therefore,

$$\begin{aligned}f(x + \Delta x) &\approx (x^3 - 7x^2 + 10) + \Delta x (3x^2 - 14x) \\ \Rightarrow f(5.001) &\approx (5^3 - 7(5)^2 + 10) + (0.001)(3(5)^2 - 14(5)) \\ &= (125 - 175 + 10) + (0.001)(75 - 70) \\ &= -40 + (0.001)(5) = -40 + 0.005 = -39.995\end{aligned}$$

---

## Question 6

The circle  $x^2 + y^2 + 3x - y + 2 = 0$  cuts an intercept on X-axis of length

**Options:**

- A. 3
- B. 4
- C. 2
- D. 1

**Answer: D**

**Solution:**

Given equation of circle is  $x^2 + y^2 + 3x - y + 2 = 0$ .

On comparing this equation with  $x^2 + y^2 + 2gx + 2fy + c = 0$ , we get  $g = \frac{3}{2}$ ,  $f = -\frac{1}{2}$  and  $c = 2$

$$\begin{aligned}\text{Now, the length of intercept on X-axis} &= 2\sqrt{g^2 - c} \\ &= 2\sqrt{\left(\frac{3}{2}\right)^2 - 2} = 2\sqrt{\frac{9}{4} - 2} = 2\sqrt{\frac{1}{4}} = 2\left(\frac{1}{2}\right) = 1\end{aligned}$$

---

## Question 7

Let  $f(x) = a + (x - 4)^{\frac{4}{9}}$ , then minima of  $f(x)$  is

**Options:**

- A. 4

- B.  $a$
- C.  $a - 4$
- D. None of these

**Answer: B**

**Solution:**

$$\because f(x) = a + (x - 4)^{4/9}$$

$$\therefore f'(x) = 0 + \frac{4}{9}(x - 4)^{-5/9}$$

Clearly, at  $x = 4$ ,  $f'(x)$  is not defined

Hence,  $x = 4$  is the point of extremum.

$$\because f(4) = a + (4 - 4)^{4/9} = a$$

$\therefore$  The minimum value of  $f(x)$  is  $a$ .

## Question 8

If  $f(x) = \begin{cases} 2 \sin x & ; & -\pi \leq x \leq \frac{-\pi}{2} \\ a \sin x + b & ; & -\frac{\pi}{2} < x < \frac{\pi}{2} \\ \cos x & ; & \frac{\pi}{2} \leq x \leq \pi \end{cases}$  and it is continuous on  $[-\pi, \pi]$ , then

**Options:**

- A.  $a = 1$  and  $b = 1$
- B.  $a = -1$  and  $b = -1$
- C.  $a = -1$  and  $b = 1$
- D.  $a = 1$  and  $b = -1$

**Answer: D**

**Solution:**

$$\text{At, } x = \frac{\pi}{2}$$

$$\text{LHL} = \lim_{x \rightarrow \pi/2^-} (a \sin x + b) = a + b$$

$$\text{RHL} = \lim_{x \rightarrow \pi/2^+} (\cos x) = 0$$

Since,  $f(x)$  is continuous at  $x = \pi/2$

$$\therefore a + b = 0 \quad \dots \text{(i)}$$

$$\text{At, } x = -\frac{\pi}{2}$$

$$\text{LHL} = \lim_{x \rightarrow -\pi/2^-} (2 \sin x) = -2$$

$$\text{RHL} = \lim_{x \rightarrow -\pi/2^+} (a \sin x + b) = -a + b$$

Since,  $f(x)$  is continuous at  $x = -\pi/2$

$$\therefore -a + b = -2 \quad \dots \text{(ii)}$$

On solving Eqs. (i) and (ii), we get  $a = 1$  and  $b = -1$

---

## Question 9

The value of  $\lim_{x \rightarrow \infty} \left( \frac{x^2 - 2x + 1}{x^2 - 4x + 2} \right)^{2x}$  is

**Options:**

A.  $e^2$

B.  $e^4$

C.  $e$

D.  $e^{16}$

**Answer: B**

**Solution:**

$$\begin{aligned}
\text{Let } L &= \lim_{x \rightarrow \infty} \left( \frac{x^2 - 2x + 1}{x^2 - 4x + 2} \right)^{2x} \\
\Rightarrow \ln L &= \lim_{x \rightarrow \infty} \left[ 2x \ln \left( \frac{x^2 - 2x + 1}{x^2 - 4x + 2} \right) \right] \\
\Rightarrow \ln L &= \lim_{x \rightarrow \infty} \left[ 2x \ln \left( 1 + \frac{2x - 1}{x^2 - 4x + 2} \right) \right] \\
\Rightarrow \ln L &= \lim_{x \rightarrow \infty} \left[ 2x \left( \frac{2x-1}{x^2-4x+2} - \frac{\left(\frac{2x-1}{x^2-4x+2}\right)^2}{2} + \frac{\left(\frac{2x-1}{x^2-4x+2}\right)^3}{3} \right) \dots \right] \\
\Rightarrow \ln L &= \left( \lim_{x \rightarrow \infty} \frac{2x(2x-1)}{x^2-4x+2} \right) - 0 + 0 \dots \\
\Rightarrow \ln L &= \lim_{x \rightarrow \infty} \frac{4x^2 \left(1 - \frac{1}{2x}\right)}{x^2 \left(1 - \frac{4}{x} + \frac{2}{x}\right)} \\
\ln L &= \frac{4(1-0)}{(1-0+0)} \\
\Rightarrow \ln L &= 4 \\
\Rightarrow L &= e^4
\end{aligned}$$

---

## Question 10

$S \equiv x^2 + y^2 - 2x - 4y - 4 = 0$  and  $S' \equiv x^2 + y^2 - 4x - 2y - 16 = 0$  are two circles the point  $(-2, -1)$  lies

**Options:**

- A. inside  $S'$  only
- B. inside  $S$  only
- C. inside  $S$  and  $S'$
- D. outside  $S$  and  $S'$

**Answer: A**

**Solution:**

$$\begin{aligned}
S(-2, -1) &= (-2)^2 + (-1)^2 - 2(-2) - 4(-1) - 4 \\
&= 4 + 1 + 4 + 4 - 4 = 9 > 0
\end{aligned}$$

$\therefore (-2, -1)$  lies outside of  $S$



$$\begin{aligned} S(-2, -1) &= (-2)^2 + (-1)^2 - 4(-2) - 2(-1) - 16 \\ &= 4 + 1 + 8 + 2 - 16 = -1 < 0 \end{aligned}$$

$\therefore (-2, -1)$  lies inside of  $S'$

Thus,  $(-2, -1)$  lies inside  $S'$  only.

---

## Question 11

**A number  $n$  is chosen at random from  $s = \{1, 2, 3, \dots, 50\}$ . Let  $A = \{n \in s : n \text{ is a square}\}$ ,  $B = \{n \in s : n \text{ is a prime}\}$  and  $C = \{n \in s : n \text{ is a square}\}$ . Then, correct order of their probabilities is**

**Options:**

- A.  $p(A) < p(B) < p(C)$
- B.  $p(A) > p(B) > p(C)$
- C.  $p(B) < p(A) < p(C)$
- D.  $p(A) > p(C) > p(B)$

**Answer: B**

**Solution:**

Given,  $S = \{1, 2, 3, \dots, 50\}$

$$A = \left\{ n \in S : n + \frac{50}{n} > 27 \right\}$$

$$= \{ n \in S : n^2 - 27n + 50 > 0 \}$$

$$= \{ n \in S : (n - 25)(n - 2) > 0 \}$$

$$= \{ n \in S : n < 2 \text{ or } n > 25 \}$$

$$= \{1, 26, 27, 28, \dots, 50\}$$

$$\Rightarrow n(A) = 26$$

$$B = \{ n \in S : n \text{ is prime} \}$$

$$= \{2, 3, 5, 7, 11, 13, 17, 19, 23,$$

$$29, 31, 37, 41, 43, 47\}$$

$$\Rightarrow n(B) = 15$$

$$C = \{ n \in S : n \text{ is a square} \} = \{1, 4, 9, 16, 25, 36, 49\}$$

$$\Rightarrow n(C) = 7$$

$$\therefore p(A) = \frac{n(A)}{n(S)} = \frac{26}{50},$$

$$\Rightarrow p(B) = \frac{n(B)}{n(S)} = \frac{15}{50},$$

$$p(C) = \frac{n(C)}{n(S)} = \frac{7}{50}$$

$$\therefore p(A) > p(B) > p(C)$$

## Question 12

**The feasible region for the inequations**

**$x + 2y \geq 4, 2x + y \leq 6, x, y \geq 0$  is**

**Options:**

A.

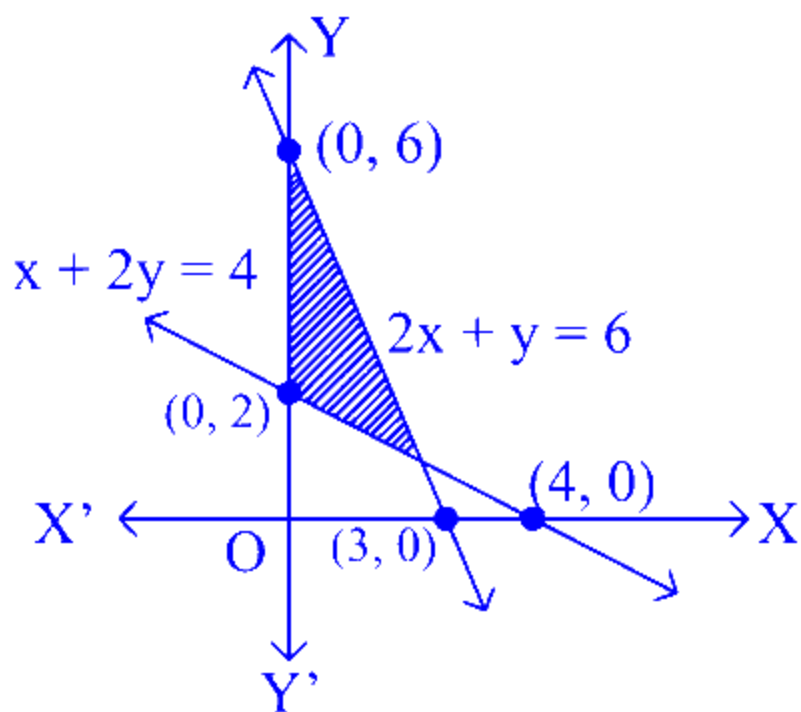

B.

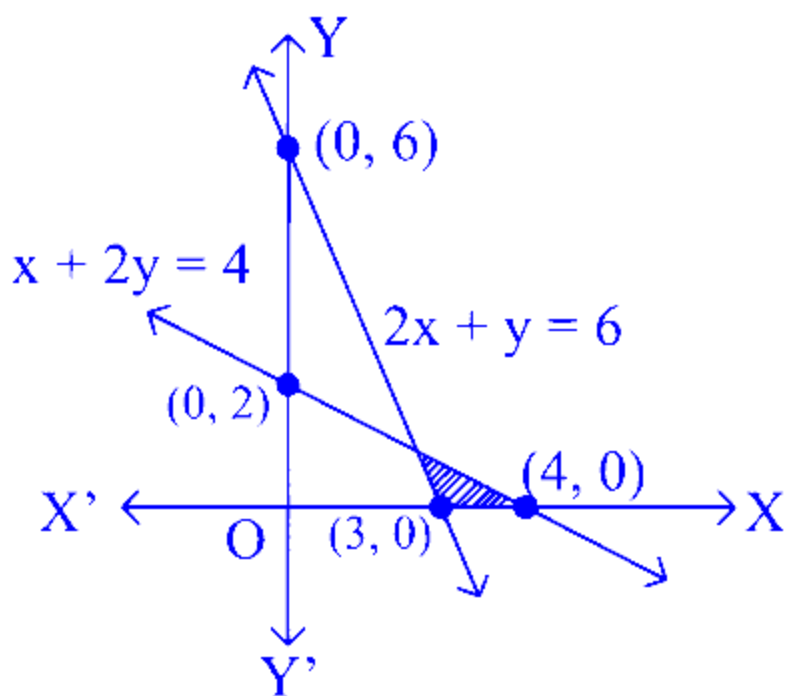

C.

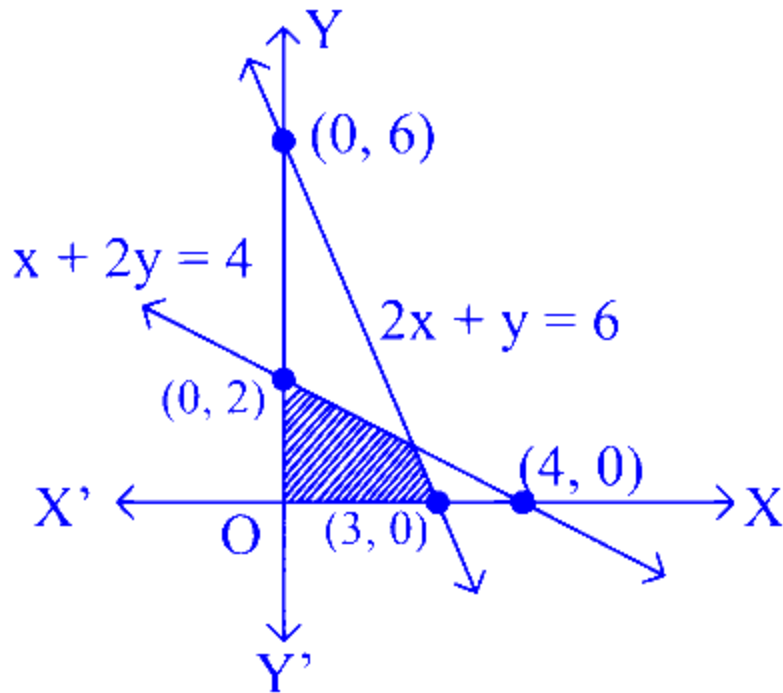

D.

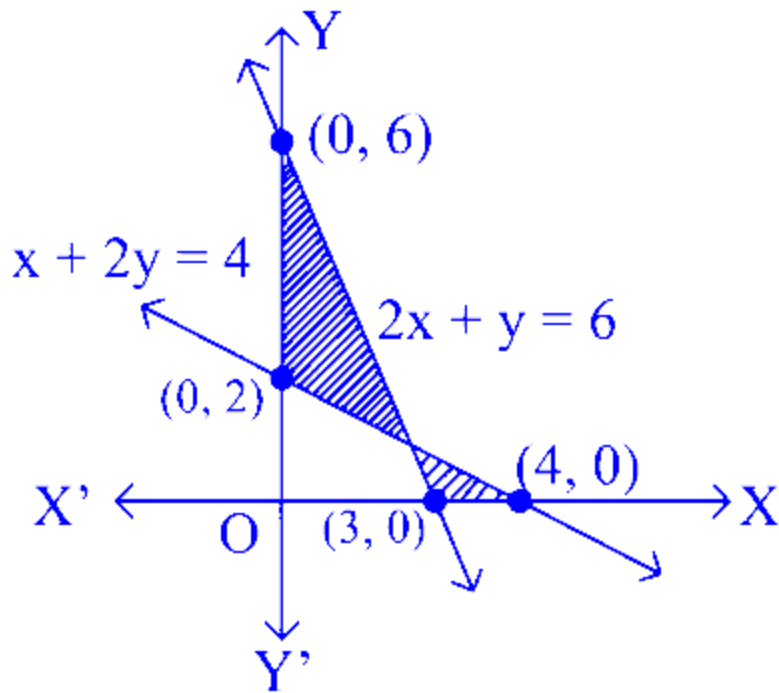

**Answer: A**

**Solution:**

The given inequations are  $x + 2y \geq 4$ ,  $2x + y \leq 6$ ,  $x, y \leq 0$ .

According to the inequations  $x, y \geq 0$ , the feasible region be the first quadrant (including positive X and positive Y-axis). According to the inequation  $x + 2y \geq 4$ , the feasible region be the region above or on the line  $x + 2y = 4$ .

According to the inequation  $2x + y \leq 6$ , the feasible region be the region below or on the line  $2x + y = 6$ . Now, the common feasible region will be the required feasible region.

Thus, option (a) is correct.

---

## Question 13

**The maximum value of  $Z = 10x + 16y$ , subject to constraints  $x \geq 0, y \geq 0, x + y \leq 12, 2x + y \leq 20$  is**

**Options:**

A. 144

B. 192

C. 120

D. 240

**Answer: B**

**Solution:**

Given, constraints are  $x \geq 0, y \geq 0, x + y \leq 12, 2x + y \leq 20$

The feasible region is  $OABCO$ .

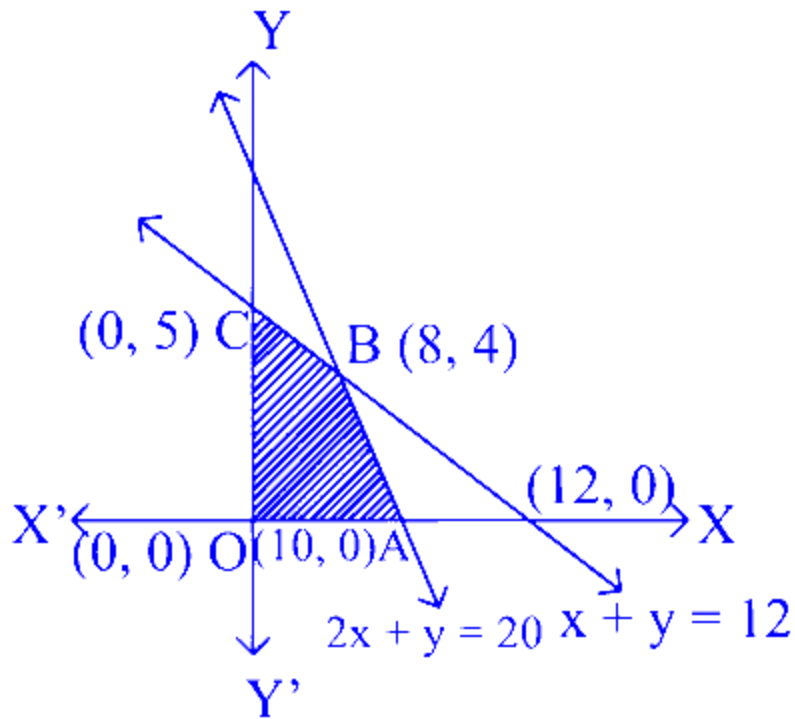

$$\therefore Z = 10x + 16y$$

$$\text{At, } O(0,0), Z = 10(0) + 16(0) = 0$$

$$\text{At, } A(10,0), Z = 10(10) + 16(0) = 100$$

$$\text{At, } B(8,4), Z = 10(8) + 16(4) = 144$$

$$\text{At, } C(0,12), Z = 10(0) + 16(12) = 192$$

Hence, the maximum value of  $Z$  is 192.

## Question 14

If  $A = \begin{bmatrix} 2 & 2 \\ 3 & 4 \end{bmatrix}$ , then  $A^{-1}$  equals to

Options:

A.  $\begin{bmatrix} 2 & 1 \\ -3/2 & -1 \end{bmatrix}$

B.  $\begin{bmatrix} 2 & -1 \\ -3/2 & 1 \end{bmatrix}$

C.  $\begin{bmatrix} -2 & 1 \\ 3/2 & -1 \end{bmatrix}$

D.  $\begin{bmatrix} -2 & -1 \\ 3/2 & 1 \end{bmatrix}$

**Answer: B**

**Solution:**

Given,  $A = \begin{bmatrix} 2 & 2 \\ 3 & 4 \end{bmatrix}$

$\therefore |A| = \begin{vmatrix} 2 & 2 \\ 3 & 4 \end{vmatrix} = 2 \times 4 - 3 \times 2 = 8 - 6 = 2$

Now,  $A_{11} = 4, A_{12} = -3, A_{21} = -2$  and  $A_{22} = 2$

$\therefore \text{adj}A = \begin{bmatrix} 4 & -3 \\ -2 & 2 \end{bmatrix}^T = \begin{bmatrix} 4 & -2 \\ -3 & 2 \end{bmatrix}$

$A^{-1} = \frac{1}{|A|} \text{adj}A = \frac{1}{2} \begin{bmatrix} 4 & -2 \\ -3 & 2 \end{bmatrix}$

$= \begin{bmatrix} 2 & -1 \\ -3/2 & 1 \end{bmatrix}$

---

## Question 15

If  $A$  is a matrix of order 4 such that  $A(\text{adj} A) = 10 I$ , then  $|\text{adj} A|$  is equal to

**Options:**

A. 10

B. 100

C. 1000

D. 10000

**Answer: C**

**Solution:**

Given,  $A(\text{adj } A) = 10I$

We know that  $A(\text{adj } A) = |A|I$

$$\therefore 10I = |A|I$$

$$\Rightarrow |A| = 10$$

We know that  $|\text{adj } A| = |A|^{n-1}$ , where  $n$  is order of  $A$

$$\therefore |\text{adj } A| = |A|^{4-1} = 10^3 = 1000$$

---

## Question 16

If  $A = \begin{bmatrix} k+1 & 2 \\ 4 & k-1 \end{bmatrix}$  is a singular matrix, then possible values of  $k$  are

**Options:**

A.  $\pm 1$

B.  $\pm 2$

C.  $\pm 3$

D.  $\pm 4$

**Answer: C**

**Solution:**

Given,  $A = \begin{bmatrix} k+1 & 2 \\ 4 & k-1 \end{bmatrix}$  is a singular matrix.

$$\therefore |A| = 0$$

$$\Rightarrow \begin{vmatrix} k+1 & 2 \\ 4 & k-1 \end{vmatrix} = 0$$

$$\Rightarrow (k+1)(k-1) - 4 \times 2 = 0$$

$$\Rightarrow k^2 - 1 - 8 = 0$$

$$\Rightarrow k^2 - 9 = 0$$

$$\Rightarrow k^2 = 9$$

$$\Rightarrow k = \pm 3$$



---

## Question 17

The angle between the vectors  $\mathbf{a} = \hat{\mathbf{i}} + 2\hat{\mathbf{j}} + 2\hat{\mathbf{k}}$  and  $\mathbf{b} = \hat{\mathbf{i}} + 2\hat{\mathbf{j}} - 2\hat{\mathbf{k}}$  is

Options:

A.  $\sin^{-1}(1/9)$

B.  $\sin^{-1}(8/9)$

C.  $\cos^{-1}(8/9)$

D.  $\cos^{-1}(1/9)$

**Answer: D**

**Solution:**

We have,  $\mathbf{a} = \hat{\mathbf{i}} + 2\hat{\mathbf{j}} + 2\hat{\mathbf{k}}$  and  $\mathbf{b} = \hat{\mathbf{i}} + 2\hat{\mathbf{j}} - 2\hat{\mathbf{k}}$

Clearly,  $|\mathbf{a}| = \sqrt{1 + 4 + 4} = \sqrt{9} = 3$

and  $|\mathbf{b}| = \sqrt{1 + 4 + 4} = \sqrt{9} = 3$

$\therefore \mathbf{a} \cdot \mathbf{b} = |\mathbf{a}||\mathbf{b}| \cos \theta$

$\Rightarrow \cos \theta = \frac{1 \cdot 1 + 2 \cdot 2 + 2 \cdot (-2)}{3 \times 3}$

$\Rightarrow \cos \theta = \frac{1+4-4}{9} \Rightarrow \cos \theta = \frac{1}{9}$

$\therefore \theta = \cos^{-1}\left(\frac{1}{9}\right)$

---

## Question 18

If the vectors  $\mathbf{a} = 2\hat{\mathbf{i}} - 3\hat{\mathbf{j}} + 4\hat{\mathbf{k}}$ ;  $\mathbf{b} = \hat{\mathbf{i}} + 2\hat{\mathbf{j}} - \hat{\mathbf{k}}$  and  $\mathbf{c} = m\hat{\mathbf{i}} - \hat{\mathbf{j}} + 2\hat{\mathbf{k}}$  are coplanar, then the value of  $m$  is

Options:

A.  $\frac{5}{8}$

B.  $\frac{8}{5}$

C.  $\frac{-7}{4}$

D.  $\frac{2}{3}$

**Answer: B**

**Solution:**

Since, vectors  $\mathbf{a}$ ,  $\mathbf{b}$  and  $\mathbf{c}$  are coplanar

$$\therefore [\mathbf{a} \ \mathbf{b} \ \mathbf{c}] = 0 \Rightarrow \mathbf{a} \cdot (\mathbf{b} \times \mathbf{c}) = 0$$

$$\begin{aligned} \text{Now, } \mathbf{b} \times \mathbf{c} &= \begin{vmatrix} \hat{\mathbf{i}} & \hat{\mathbf{j}} & \hat{\mathbf{k}} \\ 1 & 2 & -1 \\ m & -1 & 2 \end{vmatrix} \\ &= \hat{\mathbf{i}}(4 - 1) - \hat{\mathbf{j}}(2 + m) + \hat{\mathbf{k}}(-1 - 2m) \\ &= 3\hat{\mathbf{i}} - (2 + m)\hat{\mathbf{j}} - (1 + 2m)\hat{\mathbf{k}} \end{aligned}$$

and

$$\begin{aligned} \mathbf{a} \cdot (\mathbf{b} \times \mathbf{c}) &= (2\hat{\mathbf{i}} - 3\hat{\mathbf{j}} + 4\hat{\mathbf{k}}) \cdot (3\hat{\mathbf{i}} - (2 + m)\hat{\mathbf{j}} - (1 + 2m)\hat{\mathbf{k}}) \\ &= 2(3) + 3(2 + m) - 4(1 + 2m) \\ &= 6 + 6 + 3m - 4 - 8m = 8 - 5m \end{aligned}$$

$$\therefore \mathbf{a} \cdot (\mathbf{b} \times \mathbf{c}) = 0$$

$$\therefore 8 - 5m = 0 \Rightarrow m = \frac{8}{5}$$

---

## Question 19

The maximum value of  $Z = 12x + 13y$ , subject to constraints  $x \geq 0, y \geq 0, x + y \leq 5$  and  $3x + y \leq 9$  is

**Options:**

A. 63

B. 65

C. 60

D. 117

**Answer: B**

**Solution:**

Given constraints are  $x \geq 0, y \geq 0, x + y \leq 5$  and  $3x + y \leq 9$  and  $z = 12x + 13y$

The feasible region is  $OABCO$ .

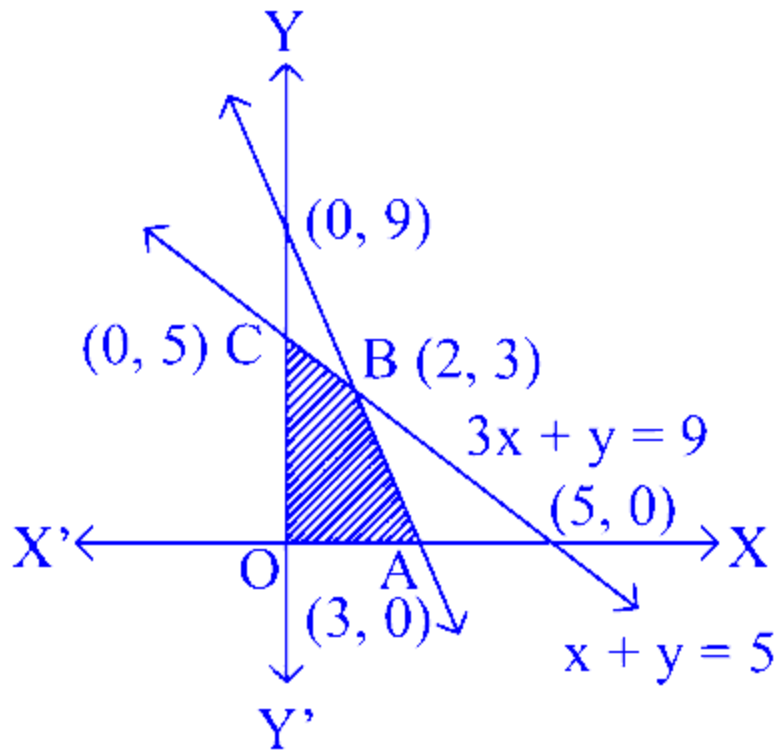

$$\because Z = 12x + 13y$$

$$\text{At, } O(0, 0), Z = 12(0) + 13(0) = 0$$

$$\text{At, } A(3, 0), Z = 12(3) + 13(0) = 36$$

$$\text{At, } B(2, 3), Z = 12(2) + 13(3) = 63$$

$$\text{At, } C(0, 5), Z = 12(0) + 13(5) = 65$$

Here, maximum value of  $Z$  is 65.

---

## Question 20

$\mathbf{a} = 2\hat{\mathbf{i}} + \hat{\mathbf{j}} - \hat{\mathbf{k}}$ ,  $\mathbf{b} = \hat{\mathbf{i}} - \hat{\mathbf{j}}$  and  $\mathbf{c} = 5\hat{\mathbf{i}} - \hat{\mathbf{j}} + \hat{\mathbf{k}}$ , then unit vector parallel to  $\mathbf{a} + \mathbf{b} - \mathbf{c}$  but in opposite direction is

**Options:**

A.  $\frac{1}{3}(2\hat{\mathbf{i}} - \hat{\mathbf{j}} + 2\hat{\mathbf{k}})$

B.  $\frac{1}{2}(2\hat{\mathbf{i}} - \hat{\mathbf{j}} + 2\hat{\mathbf{k}})$

C.  $\frac{1}{3}(2\hat{\mathbf{i}} - \hat{\mathbf{j}} - 2\hat{\mathbf{k}})$

D. None of these

**Answer: A**

**Solution:**

Given,  $\mathbf{a} = 2\hat{\mathbf{i}} + \hat{\mathbf{j}} - \hat{\mathbf{k}}$ ,  $\mathbf{b} = \hat{\mathbf{i}} - \hat{\mathbf{j}}$  and  $\mathbf{c} = 5\hat{\mathbf{i}} - \hat{\mathbf{j}} + \hat{\mathbf{k}}$

$$\begin{aligned}\therefore \mathbf{a} + \mathbf{b} - \mathbf{c} &= (2 + 1 - 5)\hat{\mathbf{i}} + (1 - 1 + 1)\hat{\mathbf{j}} + (-1 + 0 - 1)\hat{\mathbf{k}} \\ &= -2\hat{\mathbf{i}} + \hat{\mathbf{j}} - 2\hat{\mathbf{k}} = -(2\hat{\mathbf{i}} - \hat{\mathbf{j}} + 2\hat{\mathbf{k}})\end{aligned}$$

Now, the unit vector in the direction of  $\mathbf{a} + \mathbf{b} - \mathbf{c}$  be

$$\frac{-(2\hat{\mathbf{i}} - \hat{\mathbf{j}} + 2\hat{\mathbf{k}})}{\sqrt{2^2 + (-1)^2 + 2^2}} = -\frac{1}{3}(2\hat{\mathbf{i}} - \hat{\mathbf{j}} + 2\hat{\mathbf{k}})$$

$\therefore$  The required unit vector be  $\frac{1}{3}(2\hat{\mathbf{i}} - \hat{\mathbf{j}} + 2\hat{\mathbf{k}})$ .

---

## Question 21

The plane  $x - 2y + z = 0$  is parallel to the line

**Options:**

A.  $\frac{x-3}{4} = \frac{y-4}{5} = \frac{z-3}{6}$

B.  $\frac{x-2}{1} = \frac{y-2}{-2} = \frac{z-3}{1}$

C.  $\frac{x-2}{2} = \frac{y-3}{3} = \frac{z-4}{4}$

D.  $\frac{x-4}{3} = \frac{y-5}{4} = \frac{z-6}{3}$

**Answer: A**

## Solution:

Consider the equation of line given in option (a). The DR's of this line or (4, 5, 6).

We know that if the line  $\frac{x-x_0}{a_1} = \frac{y-y_0}{b_1} = \frac{z-z_0}{c_1}$  is parallel to the plane  $a_2x + b_2y + c_2z + d = 0$ , then  $a_1a_2 + b_1b_2 + c_1c_2 = 0$ , that is the normal to the plane is perpendicular to the line.

Here, the vector  $\hat{i} - 2\hat{j} + \hat{k}$  is normal to the plane  $x - 2y + z = 0$  and  $4(1) + 5(-2) + 6(1) = 4 - 10 + 6 = 10 - 10 = 0$

So, option (a) is correct.

---

## Question 22

$\int \frac{x dx}{2(1+x)^{3/2}}$  is equal to

Options:

- A.  $\frac{2+x}{\sqrt{1+x}} + C$
- B.  $\frac{2+x}{x\sqrt{1+x}} + C$
- C.  $\frac{x}{\sqrt{1+x}} + C$
- D.  $-\frac{x}{\sqrt{1+x}} + C$

**Answer: A**

**Solution:**

Let  $I = \int \frac{x dx}{2(1+x)^{3/2}}$

On putting,  $1 + x = t$ , we get  $dx = dt$

$$\begin{aligned}
\therefore I &= \int \frac{(t-1)dt}{2t^{3/2}} = \frac{1}{2} \left[ \int t^{-1/2} dt - \int t^{-3/2} dt \right] \\
&= \frac{1}{2} \left[ \frac{t^{1/2}}{1/2} - \frac{t^{-1/2}}{-1/2} \right] + C \\
&= \frac{1}{2} \times 2 \left[ \sqrt{t} + \frac{1}{\sqrt{t}} \right] + C \\
&= \frac{t+1}{\sqrt{t}} + C = \frac{x+2}{\sqrt{1+x}} + C
\end{aligned}$$

---

## Question 23

$\int \frac{4^x}{\sqrt{1-16^x}} dx$  is equal to

**Options:**

A.  $(\log 4) \sin^{-1} 4^x + C$

B.  $\frac{1}{4} \sin^{-1} (4^x) + C$

C.  $\frac{1}{\log 4} \sin^{-1} 4^x + C$

D.  $4 \log 4 \sin^{-1} 4 + C$

**Answer: C**

**Solution:**

$$\begin{aligned}
\text{Let } I &= \int \frac{4^x}{\sqrt{1-16^x}} dx \\
&= \int \frac{4^x}{\sqrt{1-(4^x)^2}} dx
\end{aligned}$$

On putting,  $4^x = t$ , we get  $4^x \log 4 dx = dt$

$$\begin{aligned}\Rightarrow 4^x dx &= \frac{dt}{\log 4} \\ \therefore I &= \frac{1}{\log 4} \int \frac{dt}{\sqrt{1-t^2}} \\ &= \frac{1}{\log 4} \sin^{-1} t + C \\ &= \frac{1}{\log 4} \sin^{-1} 4^x + C\end{aligned}$$

---

## Question 24

$$\int_{-\pi/2}^{\pi/2} \sin^2 x dx \text{ is equal to}$$

**Options:**

A. 0

B.  $\pi$

C.  $\frac{\pi}{2}$

D.  $\frac{\pi}{4}$

**Answer: C**

**Solution:**

Let  $f(x) = \sin^2 x$

$$\begin{aligned}\text{Now, } f(-x) &= \sin^2(-x) = (\sin(-x))^2 \\ &= (-\sin x)^2 = \sin^2 x = f(x)\end{aligned}$$

So,  $f$  is an even function

$$\begin{aligned} \therefore \int_{-\pi/2}^{\pi/2} \sin^2 x &= 2 \int_0^{\pi/2} \sin^2 x dx \\ &\left[ \because \int_{-a}^a f(x) dx = 2 \int_0^a f(x) dx, \text{ if } f \text{ is even} \right] \\ 2 \int_0^{\pi/2} \frac{1 - \cos 2x}{2} dx &= \left[ x - \frac{\sin 2x}{2} \right]_0^{\pi/2} \\ &= \left( \frac{\pi}{2} - \frac{\sin 2 \times \pi/2}{2} \right) - \left( 0 - \frac{\sin(2 \times 0)}{2} \right) \\ &= \left( \frac{\pi}{2} - 0 \right) - (0 - 0) = \frac{\pi}{2} \end{aligned}$$

---

## Question 25

The lines  $\frac{x-1}{2} = \frac{y-4}{4} = \frac{z-2}{3}$  and  $\frac{1-x}{1} = \frac{y-2}{5} = \frac{3-z}{a}$  are perpendicular to each other, then  $a$  equals to

Options:

- A.  $-6$
- B.  $6$
- C.  $\frac{22}{3}$
- D.  $-\frac{22}{3}$

**Answer: B**

**Solution:**

$$\text{Let } L_1 : \frac{x-1}{2} = \frac{y-4}{4} = \frac{z-2}{3}$$

$$\text{and } L_2 = \frac{1-x}{1} = \frac{y-2}{5} = \frac{3-z}{a}$$

$$\text{the line } L_2 \text{ can be written as } \frac{x-1}{-1} = \frac{y-2}{5} = \frac{z-3}{-a}$$

Now, the DR's of lines  $L_1$  and  $L_2$  are  $(2, 4, 3)$  and  $(-1, 5, -a)$  respectively.

Since,  $L_1$  and  $L_2$  are perpendicular to each other.



$$\therefore 2(-1) + 4(5) + 3(-a) = 0$$

$$\Rightarrow -2 + 20 - 3a = 0$$

$$\Rightarrow -3a = -18 \Rightarrow a = 6$$

---

## Question 26

If two lines  $L_1 : \frac{x-1}{2} = \frac{y+1}{3} = \frac{z-1}{4}$  and  $L_2 : \frac{x-3}{1} = \frac{y-k}{2} = z$  intersect at a point, then  $2k$  is equal to

Options:

A. 9

B.  $\frac{1}{2}$

C.  $\frac{9}{2}$

D. 1

**Answer: A**

**Solution:**

$$\text{Let } \frac{x-1}{2} = \frac{y+1}{3} = \frac{z-1}{4} = \lambda$$

Now, any point  $P$  that lies on the lines  $L_1$  has the form  $(1 + 2\lambda, -1 + 3\lambda, 1 + 4\lambda)$ .

Now, on putting  $x = 1 + 2\lambda, y = -1 + 3\lambda$  and  $z = 1 + 4\lambda$  into the equation of lines  $L_2$ , we get

$$\frac{1 + 2\lambda - 3}{1} = \frac{-1 + 3\lambda - k}{2} = 1 + 4\lambda$$

$$\Rightarrow \frac{1 + 2\lambda - 3}{1} = 1 + 4\lambda$$

$$\Rightarrow -2\lambda = 3 \Rightarrow \lambda = \frac{-3}{2}$$

$$\text{and } \frac{-1 + 3\lambda - k}{2} = 1 + 4\lambda$$

$$\Rightarrow -1 + 3\lambda - k = 2 + 8\lambda$$

$$\Rightarrow -5\lambda = 3 + k$$

$$\Rightarrow -5 \left( -\frac{3}{2} \right) = 3 + k \quad [ \because \lambda = -3/2 ]$$

$$\Rightarrow k = \frac{15}{2} - 3$$

$$\Rightarrow k = \frac{9}{2}$$

$$\Rightarrow 2k = 9$$

---

## Question 27

**A five-digits number is formed by using the digits 1, 2, 3, 4, 5 with no repetition. The probability that the numbers 1 and 5 are always together, is**

**Options:**

A.  $\frac{2}{5}$

B.  $\frac{1}{5}$

C.  $\frac{3}{5}$

D.  $\frac{1}{4}$

**Answer: A**

**Solution:**

The total number of possible five-digit numbers =  $5!$

The total number of possible five-digit numbers in which 1 and 5 are always together =  $2 \times 4!$

$$\therefore \text{Required probability} = \frac{2 \times 4!}{5!} = \frac{2 \times 4!}{5 \times 4!} = \frac{2}{5}$$

---

## Question 28

If a number  $n$  is chosen at random from the set  $\{11, 12, 13, \dots, 30\}$ . Then, the probability that  $n$  is neither divisible by 3 nor divisible by 5, is

Options:

A.  $\frac{7}{20}$

B.  $\frac{9}{20}$

C.  $\frac{11}{20}$

D.  $\frac{13}{20}$

**Answer: C**

**Solution:**

Here, number which are divisible by either 3 or 5 are 12, 15, 18, 20, 21, 24, 27, 30.

$\therefore$  Total numbers = 9

$$P(\text{number either divisible by 3 or 5}) = \frac{9}{20}$$

$$P(\text{number neither divisible by 3 nor 5})$$

$$= 1 - P(\text{number either divisible by 3 or 5})$$

$$= 1 - \frac{9}{20} = \frac{11}{20}$$

---

## Question 29

Three vertices are chosen randomly from the nine vertices of a regular 9-sided polygon. The probability that they form the vertices of an isosceles triangle, is

Options:

A.  $\frac{4}{7}$

B.  $\frac{3}{7}$

C.  $\frac{2}{7}$

D.  $\frac{5}{7}$

**Answer: B**

**Solution:**

Number of triangles formed =  ${}^9C_3$

Number of isosceles triangles =  $9 \times \left(\frac{9-1}{2}\right)$

=  $9 \times 4 = 36$

So, required probability

=  $\frac{36}{{}^9C_3} = \frac{36}{\frac{9!}{3!(9-3)!}} = \frac{36 \times 3 \times 2 \times 6!}{9 \times 8 \times 7 \times 6!} = \frac{3}{7}$

---

## Question 30

If  $A$ ,  $B$  and  $C$  are mutually exclusive and exhaustive events of a random experiment such that  $P(B) = \frac{3}{2}P(A)$  and  $P(C) = \frac{1}{2}P(B)$ , then  $P(A \cup C)$  equals to

**Options:**

A.  $\frac{10}{13}$

B.  $\frac{3}{13}$

C.  $\frac{6}{13}$

D.  $\frac{7}{13}$

**Answer: D**

**Solution:**

$$\text{Given, } P(B) = \frac{3}{2}P(A) \text{ and } P(C) = \frac{1}{2}P(B)$$

Since,  $A, B$  and  $C$  are mutually exclusive and exhaustive events.

$$\therefore P(A) + P(B) + P(C) = 1$$

$$\Rightarrow P(A) + \frac{3}{2}P(A) + \frac{1}{2} \times \frac{3}{2}P(A) = 1$$

$$\Rightarrow P(A) \left(1 + \frac{3}{2} + \frac{3}{4}\right) = 1$$

$$\Rightarrow P(A) \left(\frac{13}{4}\right) = 1 \Rightarrow P(A) = \frac{4}{13}$$

$$\therefore P(C) = \frac{1}{2} \times \frac{3}{2}P(A) = \frac{3}{4} \times \frac{4}{13} = \frac{3}{13}$$

Also,  $A, B$  and  $C$  are mutually exclusive.

$$\therefore P(A \cap B) = P(B \cap C) = P(C \cap A) = 0$$

$$\text{Now, } P(A \cup C) = P(A) + P(C) - P(A \cap C)$$

$$= \frac{4}{13} + \frac{3}{13} - 0 = \frac{7}{13}$$

---

## Question 31

**Using mathematical induction, the numbers  $a_n$  are defined by  $a_0 = 1, a_{n+1} = 3n^2 + n + a_n, (n \geq 0)$ . Then,  $a_n$  is equal to**

**Options:**

A.  $n^3 + n^2 + 1$

B.  $n^3 - n^2 + 1$

C.  $n^3 - n^2$

D.  $n^3 + n^2$

**Answer: B**

**Solution:**

$$\text{Given, } a_0 = 1, a_{n+1} = 3n^2 + n + a_n$$

$$\Rightarrow a_1 = 3(0)^2 + (0) + a_0 = 0 + 0 + 1 = 1$$

$$\Rightarrow a_2 = 3(1)^2 + (1)a_1 = 3 + 1 + 1 = 5$$

From option (b),

Let  $P(n) = n^3 - n^2 + 1$

$$P(0) = (0)^3 - (0)^2 + 1 = 1 = a_0$$

$$P(1) = (1)^3 - (1)^2 + 1 = 1 - 1 + 1 = a_1$$

$$P(2) = (2)^3 - (2)^2 + 1 = 8 - 4 + 1 = 5 = a_2$$

Thus,  $a_n = n^3 - n^2 + 1$

---

## Question 32

If  $49^n + 16^n + k$  is divisible by 64 for  $n \in N$ , then the least negative integral value of  $k$  is

**Options:**

A.  $-1$

B.  $-2$

C.  $-3$

D.  $-4$

**Answer: A**

**Solution:**

Let  $P(n) = 49^n + 16^n + k$

For  $n = 1$ , we get

$$P(1) = 49^{(1)} + 16^{(1)} + k = 65 + k$$

As  $P(1)$  is divisible by 64, we take

$$k = -1$$

$$\therefore P(1) = 65 - 1 = 64, \text{ which is divisible by } 64.$$

Thus, the least negative integral value of  $k$  be  $-1$ .

---

## Question 33

$2^{3n} - 7n - 1$  is divisible by

**Options:**

A. 64

B. 36

C. 49

D. 25

**Answer: C**

**Solution:**

$$\text{Let } P(n) = 2^{3n} - 7n - 1$$

$$\Rightarrow P(1) = 2^{3(1)} - 7(1) - 1 = 8 - 8 = 0$$

$$\Rightarrow P(2) = 2^{3(2)} - 7(2) - 1 = 64 - 15 = 49$$

$P(1)$  and  $P(2)$  are divisible by 49 .

Let  $P(k) = 2^{3k} - 7k - 1 = 49t$ , where  $t$  is an integer

Now,

$$\begin{aligned} P(k+1) &= 2^{3(k+1)} - 7(k+1) - 1 = 2^{3k} \cdot 2^3 - 7k - 7 - 1 \\ &= 8(2^{3k} - 7k - 1) + 49k \\ &= 8(49t) + 49k \\ &= 49(8t + k), \text{ where } 8t + k \text{ is an integer} \end{aligned}$$

Thus,  $2^{3n} - 7n - 1$  is divisible by 49.

---

## Question 34

The sum of  $n$  terms of the series,  $\frac{4}{3} + \frac{10}{9} + \frac{28}{27} + \dots$  is

**Options:**

A.  $\frac{3^n(2n+1)+1}{2(3^n)}$

B.  $\frac{3^n(2n+1)-1}{2(3^n)}$

C.  $\frac{3^n n - 1}{2(3^n)}$

D.  $\frac{3^n - 1}{2}$

**Answer: B**

**Solution:**

Given series is

$$\frac{4}{3} + \frac{10}{9} + \frac{28}{27} + \dots$$

The sum of the given series upto  $n$ -terms

$$\begin{aligned} & \frac{4}{3} + \frac{10}{9} + \frac{28}{27} + \dots \text{ upto } n\text{-terms} \\ &= \left(1 + \frac{1}{3}\right) + \left(1 + \frac{1}{9}\right) + \left(1 + \frac{1}{27}\right) + \dots \text{ upto } n\text{-terms} \\ &= (1 + 1 + 1 + \dots \text{ upto } n\text{-terms}) \\ & \quad + \left(\frac{1}{3} + \frac{1}{3^2} + \frac{1}{3^3} + \dots \text{ upto } n\text{-terms}\right) \\ &= n + \frac{1}{3} \left(\frac{1 - \frac{1}{3^n}}{1 - \frac{1}{3}}\right) = n + \frac{(3^n - 1)}{2(3^n)} = \frac{3^n(2n + 1) - 1}{2(3^n)} \end{aligned}$$

---

## Question 35

The value of  $\frac{1}{2!} + \frac{2}{3!} + \dots + \frac{99}{100!}$  is equal to

**Options:**

A.  $\frac{100! - 1}{100!}$

B.  $\frac{100! + 1}{100!}$

C.  $\frac{999! - 1}{999!}$

D.  $\frac{999! + 1}{999!}$

**Answer: A**

**Solution:**



$$\begin{aligned}
&\text{Given, } \frac{1}{2!} + \frac{2}{3!} + \dots + \frac{99}{100!} \\
&= \frac{2-1}{2!} + \frac{3-1}{3!} + \frac{4-1}{4!} + \dots + \frac{100-1}{100!} \\
&= \left( \frac{1}{1!} - \frac{1}{2!} \right) + \left( \frac{1}{2!} - \frac{1}{3!} \right) + \left( \frac{1}{3!} - \frac{1}{4!} \right) + \dots + \left( \frac{1}{99!} - \frac{1}{100!} \right) \\
&= 1 - \frac{1}{100!} = \frac{100! - 1}{100!}
\end{aligned}$$

---

## Question 36

If the sum of 12th and 22nd terms of an AP is 100, then the sum of the first 33 terms of an AP is

**Options:**

- A. 1700
- B. 1650
- C. 3300
- D. 3500

**Answer: B**

**Solution:**

Here,  $T_{12} = a + 11d$  and  $T_{22} = a + 21d$

Since,  $100 = T_{12} + T_{22}$

$$\begin{aligned}
\therefore 100 &= a + 11d + a + 21d \\
&\Rightarrow a + 16d = 50 \quad \dots (i)
\end{aligned}$$

Now,

$$\begin{aligned}
S_{33} &= \frac{33}{2} [2a + (33 - 1)d] \\
&= 33(a + 16d) = 33 \times 50 \quad [\text{From Eq. (i)}] \\
&= 1650
\end{aligned}$$

Thus, required sum be 1650 .

---

## Question 37

The differential equation of all non-vertical lines in a plane is

Options:

A.  $\frac{d^2y}{dx^2} = 0$

B.  $\frac{d^2x}{dy^2} = 0$

C.  $\frac{dy}{dx} = 0$

D.  $\frac{dx}{dy} = 0$

**Answer: A**

**Solution:**

The general equation of all non-vertical lines in a plane is  $ax + by = 1$ , where  $b \neq 0$ .

On differentiating both sides w.r.t.  $x$ , we get

$$a + b \frac{dy}{dx} = 0$$

Again, differentiating w.r.t  $x$ , we get

$$\Rightarrow b \frac{d^2y}{dx^2} = 0 \quad [ \because b \neq 0 ].$$

---

## Question 38

The general solution of  $\left(\frac{dy}{dx}\right)^2 = 1 - x^2 - y^2 + x^2y^2$  is

Options:

A.  $2 \sin^{-1} y = x \sqrt{1 - x^2} + \sin^{-1} x + C$

B.  $\cos^{-1} y = x \cos^{-1} x$

$$C. \sin^{-1} y = \frac{1}{2} \sin^{-1} x + C$$

$$D. 2 \sin^{-1} y = x \sqrt{1 - y^2} + C$$

**Answer: A**

**Solution:**

$$\text{Given, } \left(\frac{dy}{dx}\right)^2 = 1 - x^2 - y^2 + x^2 y^2$$

$$\Rightarrow \left(\frac{dy}{dx}\right)^2 = (1 - y^2) - x^2(1 - y^2) = (1 - x^2)(1 - y^2)$$

$$\therefore \frac{dy}{dx} = \sqrt{(1 - x^2)(1 - y^2)}$$

$$\Rightarrow \frac{dy}{\sqrt{1 - y^2}} = \sqrt{1 - x^2} dx$$

On integrating both sides, we get

$$\int \frac{dy}{\sqrt{1 - y^2}} = \int \sqrt{1 - x^2} dx$$

$$\Rightarrow \sin^{-1} y = \frac{x}{2} \sqrt{1 - x^2} + \frac{1}{2} \sin^{-1} x + \frac{C}{2}$$

$$\Rightarrow 2 \sin^{-1} y = x \sqrt{1 - x^2} + \sin^{-1} x + C$$

## Question 39

**The solution of the differential equation**

$\left(\frac{dy}{dx}\right) \tan y = \sin(x + y) + \sin(x - y)$  **is**

**Options:**

A.  $\sec x = -2 \sec y + C$

B.  $\sec y = 2 \cos y + C$

C.  $\sec y = -2 \cos x + C$

D.  $\sec x = -2 \cos y + C$

**Answer: C**

## Solution:

Given, differential equation is

$$\begin{aligned}\left(\frac{dy}{dx}\right) \tan y &= \sin(x+y) + \sin(x-y) \\ \Rightarrow \left(\frac{dy}{dx}\right) \tan y &= 2 \sin\left(\frac{x+y+x-y}{2}\right) \\ \Rightarrow \left(\frac{dy}{dx}\right) \frac{\sin y}{\cos y} &= 2 \sin x \cos y \\ \Rightarrow \frac{\sin y}{\cos^2 y} dy &= 2 \sin x dx\end{aligned}$$

On integration both sides, we get

$$\begin{aligned}\int \frac{\sin y}{\cos^2 y} dy &= \int 2 \sin x dx \\ \Rightarrow -\frac{(\cos y)^{-2+1}}{(-2+1)} &= -2 \cos x + C \\ \Rightarrow \frac{1}{\cos y} &= -2 \cos x + C \Rightarrow \sec y = -2 \cos x + C\end{aligned}$$

---

## Question 40

Find  ${}^n C_{21}$ , if  ${}^n C_{10} = {}^n C_{12}$

Options:

- A. 1
- B. 21
- C. 22
- D. 2

**Answer: C**

## Solution:

We know that if  ${}^n C_x = {}^n C_y$ , then either  $x = y$

or  $x + y = n$

Since,  ${}^n C_{10} = {}^n C_{12}$

$$\therefore 10 + 12 = n$$

$$\Rightarrow n = 22$$

Now,  ${}^n C_{21} = {}^{22} C_{21}$

$$= \frac{22!}{(22-21)!21!} = \frac{22!}{1!21!} = \frac{22 \times 21!}{1 \times 21!} = 22$$

---

## Question 41

**In a trial, the probability of success is twice the probability of failure. In six trials, the probability of at most two failure will be**

**Options:**

A.  $\frac{600}{729}$

B.  $\frac{500}{729}$

C.  $\frac{400}{729}$

D.  $\frac{496}{729}$

**Answer: D**

**Solution:**

Let the probability of failure and success be  $p$  and  $q$ , respectively.

Let  $X$  represents the number of failure

According to the question,  $q = 2p$

$$\because p + q = 1 \text{ and } q = 2p$$

$$\therefore p = \frac{1}{3} \text{ and } q = \frac{2}{3}$$

Now, required probability =  $P(X \leq 2)$

$$\begin{aligned}
&= P(X = 0) + P(X = 1) + P(X = 2) \\
&= {}^6C_0 p^0 q^6 + {}^6C_1 p^1 q^5 + {}^6C_2 p^2 q^4 \\
&= \left(\frac{2}{3}\right)^6 + 6\left(\frac{1}{3}\right)^1 \left(\frac{2}{3}\right)^5 + 15\left(\frac{1}{3}\right)^2 \left(\frac{2}{3}\right)^4 \\
&= \frac{1}{729}(64 + 192 + 240) = \frac{496}{729}
\end{aligned}$$

---

## Question 42

If  $\cos A = m \cos B$  and  $\cot\left(\frac{A+B}{2}\right) = \lambda \tan\left(\frac{B-A}{2}\right)$ , then  $\lambda$  is equal to

**Options:**

A.  $\frac{m}{m-1}$

B.  $\frac{m+1}{m}$

C.  $\frac{m+1}{m-1}$

D. None of these

**Answer: C**

**Solution:**

Given,  $\cos A = m \cos B \Rightarrow \frac{\cos A}{\cos B} = m$

On applying componendo and dividendo rule, we get

$$\begin{aligned}
\frac{\cos A + \cos B}{\cos A - \cos B} &= \frac{m + 1}{m - 1} \\
\Rightarrow \frac{2 \cos\left(\frac{A+B}{2}\right) \cos\left(\frac{A-B}{2}\right)}{2 \sin\left(\frac{A+B}{2}\right) \sin\left(\frac{B-A}{2}\right)} &= \frac{m + 1}{m - 1} \\
\Rightarrow \frac{\cot\left(\frac{A+B}{2}\right)}{\tan\left(\frac{B-A}{2}\right)} &= \frac{m + 1}{m - 1} \\
\Rightarrow \cot\left(\frac{A+B}{2}\right) &= \left(\frac{m + 1}{m - 1}\right) \tan\left(\frac{B-A}{2}\right) \\
\therefore \lambda &= \frac{m + 1}{m - 1}
\end{aligned}$$

---

## Question 43

The expression  $\frac{2 \tan A}{1 - \cot A} + \frac{2 \cot A}{1 - \tan A}$  can be written as

Options:

- A.  $\sin 2A + \cos 2A$
- B.  $2 \sec A \operatorname{cosec} A + 2$
- C.  $\tan 2A + \cot 2A$
- D.  $\sec 2A + \operatorname{cosec} 2A$

**Answer: B**

**Solution:**

$$\begin{aligned} \text{Given, } & \frac{2 \tan A}{1 - \cot A} + \frac{2 \cot A}{1 - \tan A} \\ &= \frac{\frac{2 \sin A}{\cos A}}{1 - \frac{\cos A}{\sin A}} + \frac{\frac{2 \cos A}{\sin A}}{1 - \frac{\sin A}{\cos A}} \\ &= \left( \frac{\sin A}{\cos A} \right) \left( \frac{2 \sin A}{\sin A - \cos A} \right) + \left( \frac{\cos A}{\sin A} \right) \left( \frac{2 \cos A}{\cos A - \sin A} \right) \\ &= \frac{2}{\sin A - \cos A} \left[ \frac{\sin^2 A}{\cos A} - \frac{\cos^2 A}{\sin A} \right] \\ &= \frac{2}{\sin A - \cos A} \left[ \frac{\sin^3 A - \cos^3 A}{\sin A \cos A} \right] \\ &= \frac{2(\sin A - \cos A)(\sin^2 A + \cos^2 A + \sin A \cos A)}{(\sin A - \cos A)(\sin A \cos A)} \\ &= 2 \left( \frac{1}{\sin A \cos A} + 1 \right) \\ &= 2(\sec A \operatorname{cosec} A + 1) = 2 \sec A \operatorname{cosec} A + 2 \end{aligned}$$

---

## Question 44

The general solution of  $2 \cos 4x + \sin^2 2x = 0$  is

Options:

$$\text{A. } x = \frac{n\pi}{2} \pm \sin^{-1} \left( \frac{1}{5} \right)$$

$$\text{B. } x = \frac{n\pi}{4} + \frac{(-1)^n}{4} \sin^{-1} \left( \pm \frac{2\sqrt{2}}{3} \right)$$

$$\text{C. } x = \frac{n\pi}{2} \pm \cos^{-1} \left( \frac{1}{5} \right)$$

$$\text{D. } x = \frac{n\pi}{4} + \frac{(-1)^n}{4} \cos^{-1} \left( \frac{1}{5} \right)$$

**Answer: B**

**Solution:**

$$\text{Given, } 2 \cos 4x + \sin^2 2x = 0$$

$$\Rightarrow 2 \cos 4x + \left( \frac{1 - \cos 4x}{2} \right) = 0$$

$$\Rightarrow 3 \cos 4x + 1 = 0$$

$$\Rightarrow \cos 4x = -\frac{1}{3}$$

$$\Rightarrow \sin 4x = \pm \frac{2\sqrt{2}}{3}$$

$$\Rightarrow 4x = n\pi + (-1)^n \sin^{-1} \left( \pm \frac{2\sqrt{2}}{3} \right)$$

$$\Rightarrow x = \frac{n\pi}{4} + \frac{(-1)^n}{4} \sin^{-1} \left( \pm \frac{2\sqrt{2}}{3} \right)$$

---

## Question 45

If  $2f(x^2) + 3f\left(\frac{1}{x^2}\right) = x^2 - 1, \forall x \in R - \{0\}$ , then  $f(x^8)$  is equal to

**Options:**

$$\text{A. } \frac{(1-x^8)(2x^8+3)}{5x^8}$$

$$\text{B. } \frac{(1+x^8)(2x^8-3)}{5x^8}$$

$$\text{C. } \frac{(1-x^8)(2x^8-3)}{5x^8}$$

D. None of these

**Answer: A**



## Solution:

$$\text{Given, } 2f(x^2) + 3f\left(\frac{1}{x^2}\right) = x^2 - 1 \dots \text{(i)}$$

Replacing  $x$  by  $\frac{1}{x}$ , we get

$$2f\left(\frac{1}{x^2}\right) + 3f(x^2) = \frac{1}{x^2} - 1 \dots \text{(ii)}$$

On multiplying Eq. (i) by 2, Eq. (ii) by 3 and then subtracting Eq. (i) from Eq. (ii), we get

$$\begin{aligned} 5f(x^2) &= 3\left(\frac{1}{x^2} - 1\right) - 2(x^2 - 1) \\ \Rightarrow 5f(x^2) &= \frac{3}{x^2} - 2x^2 - 1 \\ \Rightarrow f(x^2) &= \frac{1}{5}\left(\frac{3}{x^2} - 2x^2 - 1\right) \\ \Rightarrow f(x^2) &= \frac{1}{5x^2}(3 - 2x^4 - x^2) \\ \Rightarrow f(x^2) &= \frac{(2x^2 + 3)(1 - x^2)}{5x^2} \\ \therefore f(x^8) &= \frac{(1 - x^8)(2x^8 + 3)}{5x^8} \end{aligned}$$

---

## Question 46

If  $A = \{a, b, c\}$ ,  $B = \{b, c, d\}$  and  $C = \{a, d, c\}$  then  $(A - B) \times (B \cap C)$  is equal to

Options:

A.  $\{(a, c), (a, d)\}$

B.  $\{(a, b), (c, d)\}$

C.  $\{(c, a), (d, a)\}$

D.  $\{(a, c), (a, d), (b, d)\}$

**Answer: A**

**Solution:**

Given,  $A = \{a, bc\}$ ,  $B = \{b, c, d\}$  and  $C = \{a, d, c\}$   
Now,  $A - B = \{a, b, c\} - \{b, c, d\} = \{a\}$   
and  $B \cap C = \{b, c, d\} \cap \{a, d, c\} = \{c, d\}$   
 $\therefore (A - B) \times (B \cap C) = \{a\} \times \{c, d\} = \{(a, c), (a, d)\}$

---

## Question 47

If  $n(A) = p$  and  $n(B) = q$ , then the numbers of relations from the set  $A$  to the set  $B$  is

**Options:**

A.  $2^{p+q}$

B.  $2^{pq}$

C.  $p + q$

D.  $pq$

**Answer: B**

**Solution:**

Given;  $n(A) = p$  and  $n(B) = q$

$$\therefore n(A \times B) = pq$$

The number of relations from a set  $A$  to a set  $B$  is same as the total number of subset of the set  $A \times B$ .

We know that if  $n(A) = k$ , then  $n(P(A)) = 2^k$

Now, the total number of subset of  $A \times B$  be  $2^{pq}$

$\therefore$  Then number of relations from the set  $A$  to the set  $B$  is  $2^{pq}$ .

---

## Question 48

If  $z = \sqrt{3} + i$ , then the argument of  $z^2 e^{z-i}$  is equal to

**Options:**

A.  $e^{\pi/3}$

B.  $\frac{\pi}{3}$

C.  $\frac{\pi}{6}$

D.  $e^{\pi/6}$

**Answer: B**

**Solution:**

Given,  $Z = \sqrt{3} + i$   
 $\therefore \arg(z^2 e^{z-i}) = \arg[(\sqrt{3} + i)^2 e^{\sqrt{3}+i-i}]$   
 $= \arg[(2 + 2\sqrt{3}i)e^{\sqrt{3}}]$   
 $= \arg[2e^{\sqrt{3}}(1 + \sqrt{3}i)]$   
 $= \arg[(1 + \sqrt{3}i)]$   
 $= \tan^{-1}\left(\frac{\sqrt{3}}{1}\right) = \tan^{-1}\left(\tan \frac{\pi}{3}\right) = \frac{\pi}{3}$

---

## Question 49

If  $i = \sqrt{-1}$  and  $n$  is a positive integer, then  $i^n + i^{n+1} + i^{n+2} + i^{n+3}$  is equal to

**Options:**

A. 1

B.  $i$

C.  $i^n$

D. 0

**Answer: D**

**Solution:**

$$\begin{aligned}\text{Given, } i^n + i^{n+1} + i^{n+2} + i^{n+3} &= i^n (1 + i + i^2 + i^3) \\ &= i^n (1 + i + (-1) + (i^2)i) \\ &= i^n (1 + i + (-1) + (-1)i) \\ &= i^n [(1 + i) - (1 + i)] = i^n (0) = 0\end{aligned}$$

---

## Question 50

If  $\left(\frac{3}{2} + i\frac{\sqrt{3}}{2}\right)^{50} = 3^{25}(x + iy)$ , where  $x$  and  $y$  are real, then the ordered pair  $(2x, 2y)$  is

**Options:**

- A.  $(-6, 0)$
- B.  $(0, 6)$
- C.  $(0, -6)$
- D.  $(1, \sqrt{3})$

**Answer: D**

**Solution:**

$$\begin{aligned}
\text{We have, } & \left(\frac{3}{2} + i - \frac{\sqrt{3}}{2}\right)^{50} = 3^{25}(x + iy) \\
\Rightarrow & (\sqrt{3})^{50} \left(\frac{\sqrt{3}}{2} + i\frac{1}{2}\right)^{50} = 3^{25}(x + iy) \\
\Rightarrow & 3^{25} \left[-i \left(-\frac{1}{2} + i\frac{\sqrt{3}}{2}\right)\right]^{50} = 3^{25}(x + iy) \\
\Rightarrow & (-i)^{50} \omega^{50} = x + iy \\
\Rightarrow & (i^4)^{12} \cdot i^2 \cdot (\omega^3)^{16} \cdot \omega^2 = x + iy \\
\Rightarrow & (1)^{12} \cdot (-1) \cdot (1)^{16} \cdot \left(-\frac{1}{2} - i\frac{\sqrt{3}}{2}\right) = x + iy \\
\Rightarrow & \frac{1}{2} + i\frac{\sqrt{3}}{2} = x + iy \\
\Rightarrow & 1 + i\sqrt{3} = 2x + i(2y) \\
\therefore & (2x, 2y) = (1, \sqrt{3})
\end{aligned}$$

---

## Question 51

**There are 10 points in a plane out of which 4 points are collinear. How many straight lines can be drawn by joining any two of them?**

**Options:**

- A. 39
- B. 40
- C. 45
- D. 21

**Answer: B**

**Solution:**

From 10 given points,  ${}^{10}C_2$  straight lines can be drawn.

But 4 points are collinear, using 4 points,  ${}^4C_2$  straight lines can be drawn.

From 4 col linear points, 1 straight line can be drawn. So, total number of straight lines =  ${}^{10}C_2 - {}^4C_2 + 1$

$$\begin{aligned} &= \frac{10!}{8!2!} - \frac{4!}{2!2!} + 1 \\ &= 45 - 6 + 1 = 40 \end{aligned}$$

---

## Question 52

The total number of numbers greater than 1000 but less than 4000 that can be formed using 0, 2, 3, 4 (using repetition allowed) are

Options:

- A. 125
- B. 105
- C. 128
- D. 625

**Answer: C**

**Solution:**

Since, numbers should be greater than 1000 but less than 4000.

∴ The first digit: must be either 2 or 3.

It is clear that required numbers must be 4 digit numbers.

Now, there are four choices (0, 2, 3, 4), for each unit, ten and hundred place digit.

$$\begin{aligned} \text{Thus, total number} &= {}^2C_1 \times 4 \times 4 \times 4 \\ &= 2 \times 4 \times 4 \times 4 = 128 \end{aligned}$$

---

## Question 53

A polygon of n sides has 105 diagonals, then n is equal to

Options:

- A. 20

B. 21

C. 15

D. -14

**Answer: C**

**Solution:**

$\therefore$  The total number of lines joining any two points of the polygon is given by  ${}^nC_2$

So,  ${}^nC_2 = 105$

$$\Rightarrow \frac{n(n-1)}{2} = 105$$

$$\Rightarrow n^2 - n = 210$$

$$\Rightarrow n^2 - n - 210 = 0$$

$$\Rightarrow n^2 - 15n + 14n - 210 = 0$$

$$\Rightarrow n(n - 15) + 14(n - 15) = 0$$

$$\Rightarrow (n - 15)(n + 14) = 0$$

either  $n - 15 = 0$  or  $n + 14 = 0$

$$\Rightarrow n = 15 \text{ or } -14$$

$\therefore$  Number of sides cannot be negative

$$\therefore n = 15$$

---

## Question 54

**Let the equation of pair of lines  $y = m_1x$  and  $y = m_2x$  can be written as  $(y - m_1x)(y - m_2x) = 0$ . Then, the equation of the pair of the angle bisector of the line  $3y^2 - 5xy - 2x^2 = 0$  is**

**Options:**

A.  $x^2 + 5xy - y^2 = 0$

B.  $x^2 - 5xy + y^2 = 0$

C.  $x^2 - xy + y^2 = 0$

D.  $x^2 + xy - y^2 = 0$

**Answer: D**

**Solution:**

$\therefore$  Equation of angles of bisector of pair of straight line,  $ax^2 + 2bxy + by^2$  is  $\frac{x^2 - y^2}{a - b} = \frac{xy}{h}$

$\therefore$  For,  $3y^2 - 5xy - 2x^2 = 0$

$a = 3, b = -2, h = -5$

So, equation of angle bisector is

$$\frac{x^2 - y^2}{3 - (-2)} = \frac{xy}{-5}$$

$$\Rightarrow \frac{x^2 - y^2}{5} = \frac{xy}{-5} \Rightarrow x^2 - y^2 + xy = 0$$

---

## Question 55

**The distance of the point (3, 4) from the line  $3x + 2y + 7 = 0$  measured along the line parallel to  $y - 2x + 7 = 0$  is equal to**

**Options:**

A.  $\frac{24\sqrt{5}}{7}$

B.  $3\sqrt{5}$

C.  $\frac{23\sqrt{5}}{7}$

D.  $4\sqrt{5}$

**Answer: A**

**Solution:**



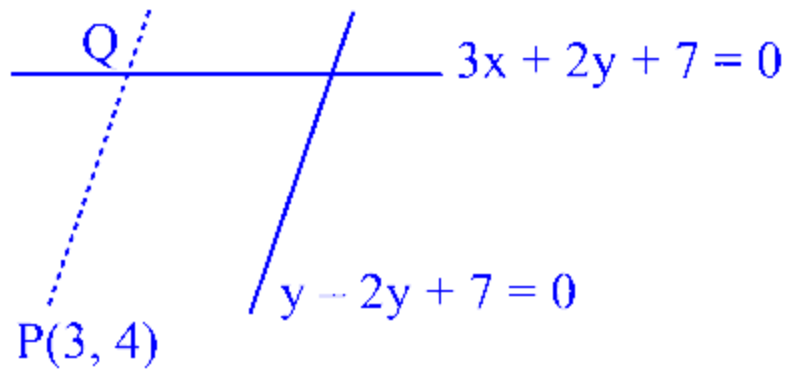

The slope of the line,  $y - 2x + 7 = 0$

$$\Rightarrow y = 2x - 7$$

$$\text{Slope } (m) = 2$$

$$\therefore \text{Slope of } PQ = m_{PQ} = 2$$

Equation of  $PQ$ ,

$$(y - 4) = 2(x - 3)$$

$$\Rightarrow y = 2x - 2 \quad \dots \text{ (i)}$$

$$\text{and } 3x + 2y + 7 = 0 \quad \dots \text{ (ii)}$$

On putting, the value of  $y$  in Eq. (ii), we get

$$3x + 2(2x - 2) + 7 = 0$$

$$\Rightarrow 7x = -3 \Rightarrow x = -\frac{3}{7}$$

$$\text{Then, } y = 2 \times \left(-\frac{3}{7}\right) - 2 = -\frac{20}{7}$$

$$\text{So, coordinates of } Q = \left(-\frac{3}{7}, -\frac{20}{7}\right)$$

Thus, distance

$$PQ = \sqrt{\left(3 - \left(-\frac{3}{7}\right)\right)^2 + \left(4 - \left(-\frac{20}{7}\right)\right)^2} = \frac{24\sqrt{5}}{7}$$

---

## Question 56

**The slope of lines which makes an angle  $60^\circ$  with the line  $y - 3x + 18 = 0$**

**Options:**

A.  $\frac{3\sqrt{3}-3}{1+3\sqrt{3}}, \frac{3\sqrt{3}+3}{1+3\sqrt{3}}$

B.  $\frac{3-\sqrt{3}}{1+3\sqrt{3}}, \frac{3+\sqrt{3}}{1-3\sqrt{3}}$

C.  $\frac{3}{1+\sqrt{3}}, \frac{3}{1-\sqrt{3}}$

D.  $\frac{\sqrt{3}-1}{3}, \frac{\sqrt{3}+1}{3}$

**Answer: B**

**Solution:**

Slope of the line,

$$y - 3x + 18 = 0$$

$$\Rightarrow y = 3x - 18 \Rightarrow \text{Slope } (m_1) = 3$$

$$\text{and angle } (\theta) = 60^\circ$$

$$\text{so, } \tan 60^\circ = \frac{m_1 - m_2}{1 + m_1 m_2}$$

$$\Rightarrow \sqrt{3} = \frac{3 - m_2}{1 + 3m_2}$$

$$\Rightarrow \frac{3 - m_2}{1 + 3m_2} = \pm\sqrt{3}$$

$$\text{Either, } \frac{3 - m_2}{1 + 3m_2} = \sqrt{3} \text{ or } \frac{3 - m_2}{1 + 3m_2} = -\sqrt{3}$$

$$\Rightarrow 3 - m_2 = \sqrt{3} + 3\sqrt{3}m_2$$

$$\text{or } 3 - m_2 = -\sqrt{3} - 3\sqrt{3}m_2$$

$$\Rightarrow m_2(1 + 3\sqrt{3}) = 3 - \sqrt{3}$$

$$\text{or } m_2(1 - 3\sqrt{3}) = 3 + \sqrt{3}$$

$$\Rightarrow m_2 = \frac{3 - \sqrt{3}}{1 + 3\sqrt{3}} \text{ or } m_2 = \frac{3 + \sqrt{3}}{1 - 3\sqrt{3}}$$

$$\therefore m_2 = \frac{3 - \sqrt{3}}{1 + 3\sqrt{3}}, \frac{3 + \sqrt{3}}{1 - 3\sqrt{3}}$$

## Question 57

**3 and 5 are intercepts of a line  $L = 0$ , then the distance of  $L = 0$  from  $(3, 7)$  is**

**Options:**

A.  $\sqrt{31}$

B.  $\sqrt{34}$

C.  $\frac{21}{\sqrt{34}}$

D.  $\frac{\sqrt{34}}{31}$

**Answer: C**

**Solution:**

If 3 and 5 are intercepts of a line  $L = 0$ , then

$$x\text{-intercept} = a = 3$$

$$y\text{-intercept} = b = 5$$

Equation of line is

$$\frac{x}{3} + \frac{y}{5} = 1 \Rightarrow 5x + 3y - 15 = 0$$

$\therefore$  Required distance

$$= \frac{5(3)+3(7)-15}{\sqrt{5^2+3^2}} = \frac{21}{\sqrt{34}}$$

---

## Question 58

**The total number of terms in the expansion of  $(x + y)^{60} + (x - y)^{60}$  is**

**Options:**

A. 60

B. 61

C. 30

D. 31

**Answer: D**

**Solution:**

$$(x + y)^{60} = {}^{60}C_0x^{60} - {}^{60}C_1x^{59}y + \dots + {}^{60}C_0x^{60} \quad \dots \text{ (i)}$$

$$(x - y)^{60} = {}^{60}C_0x^{60} + {}^{60}C_1x^{59}y + \dots + {}^{60}C_{60}y \quad \dots \text{ (ii)}$$

By adding Eq. (i) and Eq. (ii)

$$(x + y)^{60} + (x - y)^{60} = \underbrace{2({}^{60}C_0x^{60} + {}^{60}C_2x^{58}y^2 + \dots + {}^{60}C_{60}y^{60})}_{31 \text{ terms}}$$

Hence, the expansion of  $(x + y)^{60} + (x - y)^{60}$  has 31 terms.

---

## Question 59

The coefficient of  $x^{29}$  in the expansion of  $(1 - 3x + 3x^2 - x^3)^{15}$  is

**Options:**

A.  ${}^{45}C_{29}$

B.  ${}^{45}C_{28}$

C.  $-{}^{45}C_{16}$

D.  ${}^{45}C_{30}$

**Answer: C**

**Solution:**

$$(1 - 3x + 3x^2 - x^3)^{15} = [(1 - x)^3]^{15} \\ = (1 - x)^{45}$$

$$\text{So, } T_{r+1} = {}^{45}C_r(1)^{45-r}(-x)^r$$

For coefficient of  $x^{29}$ , put  $r = 29$

$$\text{Then, } T_{30} = {}^{45}C_{29}(1)^{45-29}(-x)^{29} = -{}^{45}C_{29}x^{29}$$

Hence, coefficient of  $x^{29} = -{}^{45}C_{29}$  and  $-{}^{45}C_{29} = -{}^{45}C_{16}$

---

## Question 60

**In the expansion of  $(1 + 3x + 3x^2 + x^3)^{2n}$ , the term which has greatest binomial coefficient, is**

**Options:**

- A.  $(3n)$  th term
- B.  $(3n + 1)$  th term
- C.  $(3n - 1)$  th term
- D.  $(3n + 2)$  th term

**Answer: B**

**Solution:**

$\therefore$  Middle term has greatest binomial coefficient. In the expansion of  $(1 + 3x + 3x^2 + x^3)^{2n}$

$$= ((1 + x)^3)^{2n} = (1 + x)^{6n}$$

$\therefore 6n$  is even

So, middle term of  $(1 + x)^{6n} = T_{(\frac{6n}{2}+1)}$

$$= T_{(3n+1)} = (3n + 1) \text{ th term.}$$

---

# Chemistry

## Question 61

Which of the following hexoses will form the same osazone when treated with excess phenyl hydrazine?

Options:

- A. D-glucose, D-fructose and D-galactose
- B. D-glucose, D-fructose and D-mannose
- C. D-glucose, D-mannose and D-galactose
- D. D-fructose, D-mannose and D-galactose

Answer: B

Solution:

D-glucose, D-fructose and D-mannose form the same osazone treated with excess phenyl hydrazine because they differ only 1st and 2nd carbon atoms which are transformed to the same form.

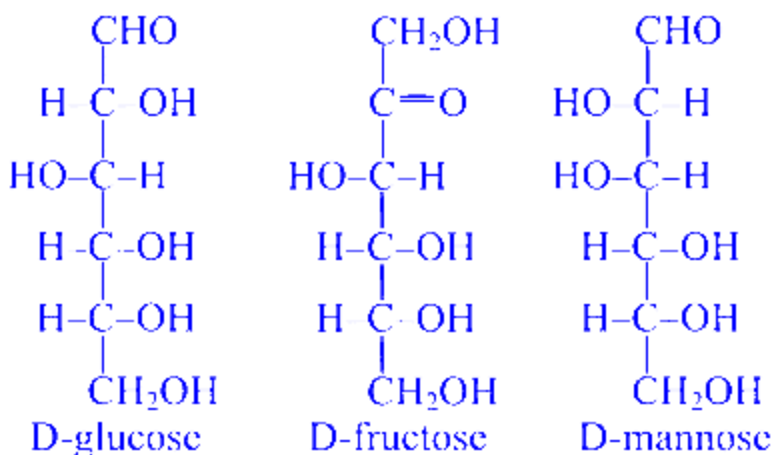

They form same osazone

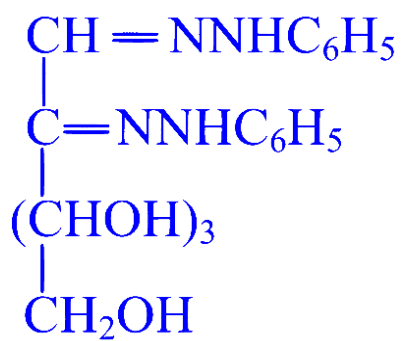

## Question 62

Product of the following reaction is

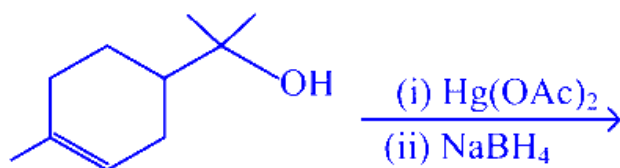

Options:

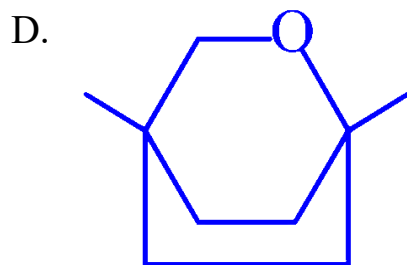
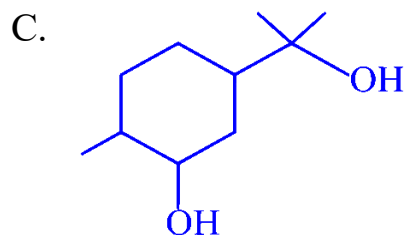
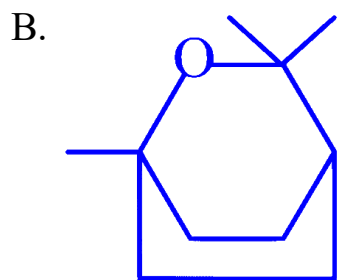
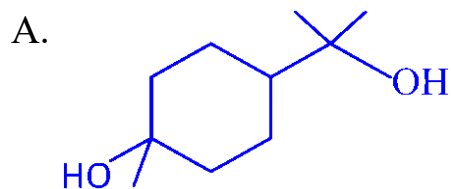

**Answer: B**

### Solution:

Addition of OH at most substituted side of the ene and final product is formed by loss of H<sub>2</sub>O resulting in the formation of ring.

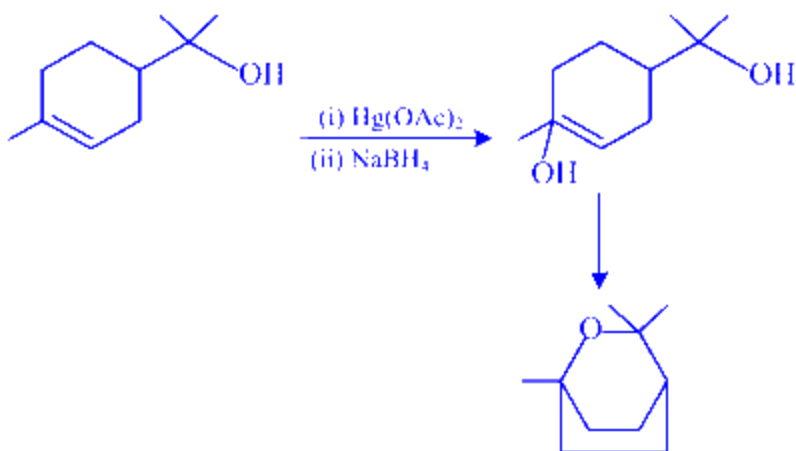

2

## Question 63

Acetophenone when reacted with a base, C<sub>2</sub>H<sub>5</sub>ONa, yields a stable compound which has the structure

Options:

A.

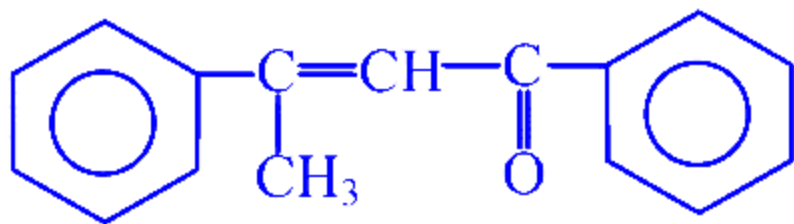



B.

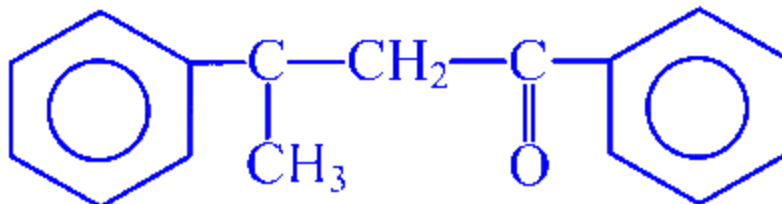

C.

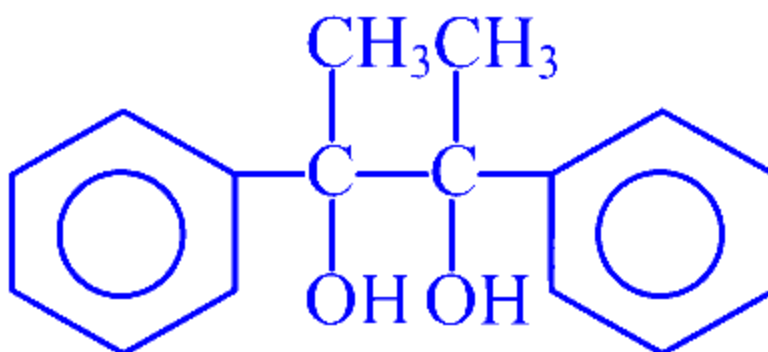

D.

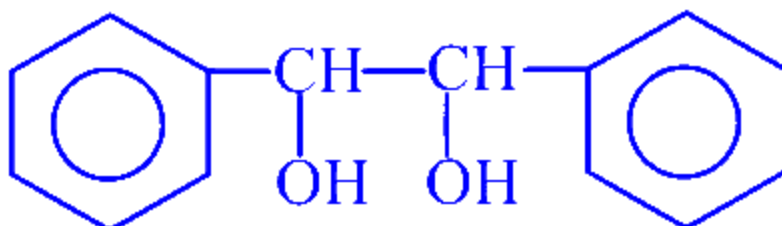

**Answer: A**

**Solution:**

Aldehydes or ketones with  $\alpha$  - H atom, in presence of dilute base, undergoes aldol condensation to give  $\beta$ -hydroxy aldehyde or ketone. On heating, aldol eliminate water molecule to form  $\alpha, \beta$ -unsaturated compounds.

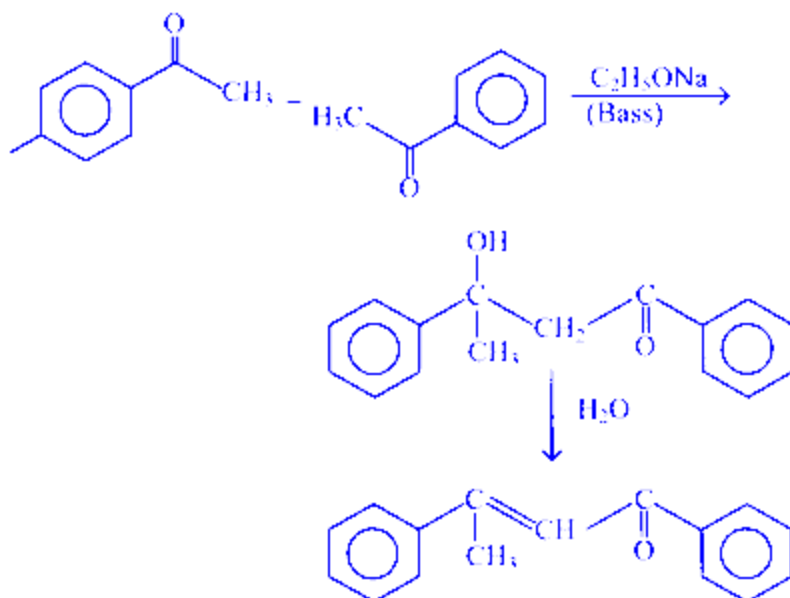

---

## Question 64

**Gabriel's synthesis is used frequency for the preparation of which of the following?**

**Options:**

- A.  $1^\circ$  amines
- B.  $1^\circ$  alcohols
- C.  $3^\circ$  amines
- D.  $3^\circ$  alcohols

**Answer: A**

**Solution:**

Gabriel's synthesis is used for the preparation of  $1^\circ$  amines.

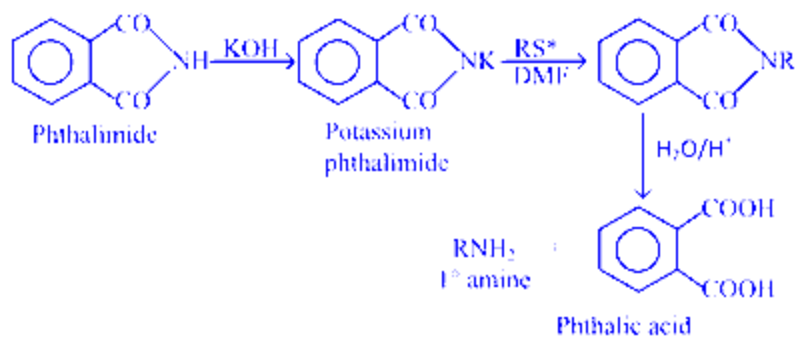

## Question 65

The product P in the reaction,

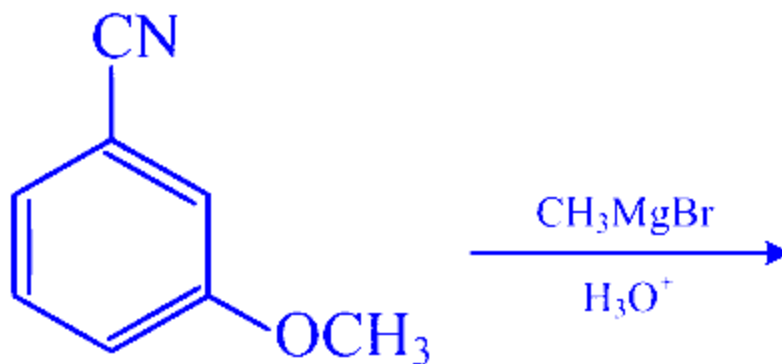

Options:

A.

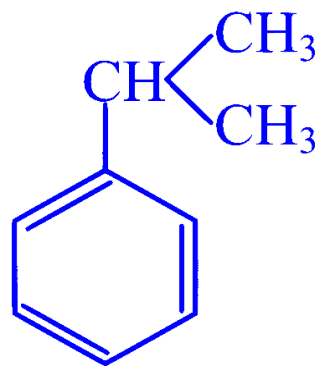

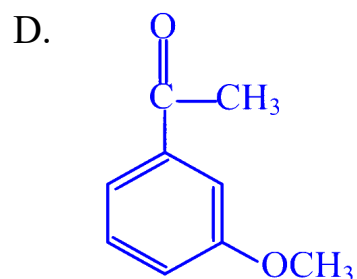
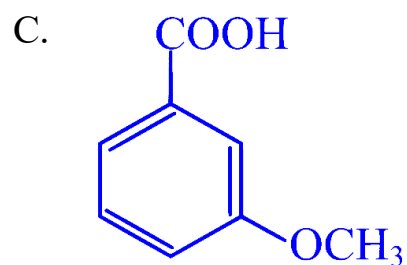
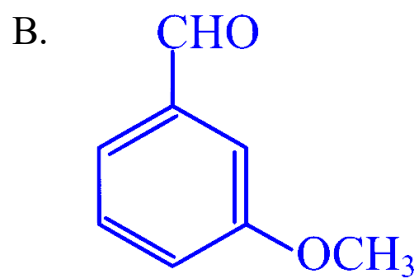

**Answer: D**

**Solution:**

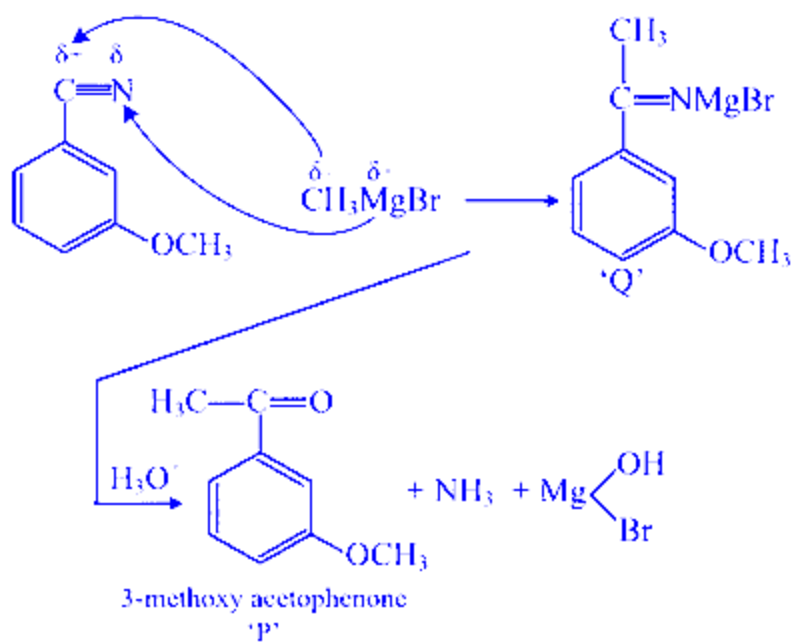

---

## Question 66

Pick out the incorrect statement(s) from the following.

1. Glucose exists in two different crystalline forms,  $\alpha$ -D-glucose and  $\beta$ -D-glucose.
2.  $\alpha$ -D-glucose and  $\beta$ -D-glucose are anomers.
3.  $\alpha$ -D-glucose and  $\beta$ -D-glucose are enantiomers.
4. Cellulose is a straight chain polysaccharide made of only  $\beta$ -D-glucose units.
5. Starch is a mixture of amylose and amylopectin, both contain unbranched chain of  $\alpha$ -D-glucose units.

Options:

- A. 1 and 2 only
- B. 2 and 3 only

C. 3 and 4 only

D. 3 and 5 only

**Answer: D**

**Solution:**

$\alpha$ -D-glucose and  $\beta$ -glucose, differ in the orientation of  $-H$  and  $-OH$  groups are first carbon atom. Such isomers are called anomers. Starch is a mixture of amylose and amylopectin but amylose is a straight chain polymer while amylopectin is a branched chain polymer of  $\alpha$ -D-glucose.

---

## Question 67

**Which of the following is incorrect?**

**Options:**

A. Primary alcohols are very easily oxidised to aldehydes, which are oxidised to acids with same number of C-atoms.

B. Secondary alcohols are very easily oxidised to ketones, which are oxidised to acids with same number of C-atoms.

C. Secondary alcohols are easily oxidised to ketones, which are oxidised to acids with lesser number of C-atoms.

D. Secondary and tertiary alcohols on oxidation form acids with lesser number of C-atoms.

**Answer: B**

**Solution:**

Primary alcohols are easily oxidised to aldehydes and then to acid, both containing the same number of carbon atoms, while secondary alcohols are easily oxidised to ketones with same number of carbon atoms, but ketone oxidised to carboxylic acid containing lesser number of carbon atoms than original alcohol.

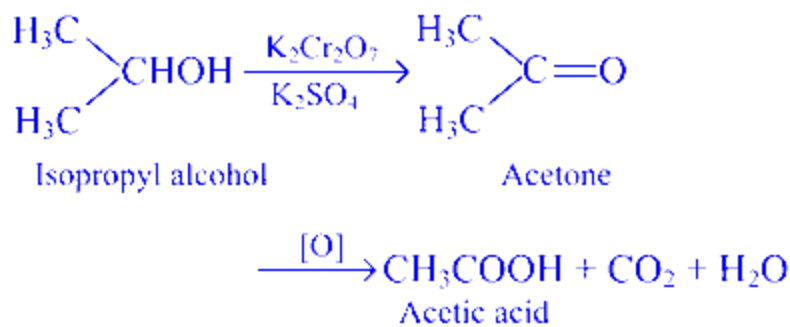

Thus all alcohols on oxidation finally give acids but acids obtained from 2° and 3° alcohols contain less C-atom.

---

## Question 68

Rank the following compounds in order of increasing basicity.

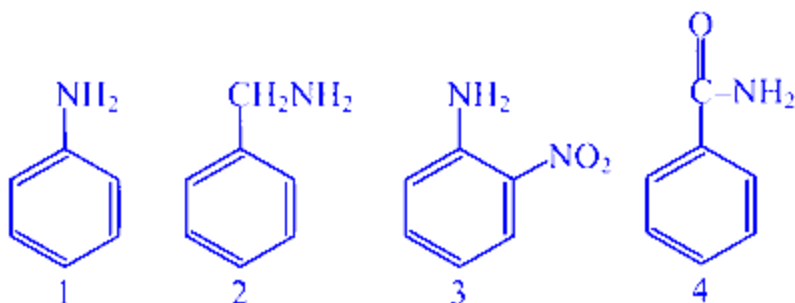

Options:

- A.  $4 < 2 < 1 < 3$
- B.  $4 < 1 < 3 < 2$
- C.  $4 < 3 < 1 < 2$
- D.  $2 < 1 < 3 < 4$

Answer: C

Solution:

As, EDG on benzene increase the basicity and EWG decrease thus when (EWG) is directly attached to benzene nucleus it is, least basic strength.

(1) aromatic amine

(2) aliphatic  $-\text{CH}_2\text{NH}_2$ , thus maximum basic strength

(3) aromatic but  $-\text{NO}_2$  group is (EWG) decreasing electron density at N-atom

(4)

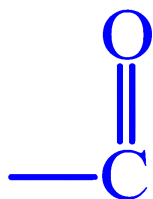

directly attached hence, least basic strength  $4 < 3 < 1 < 2$

---

## Question 69

**Ammoniacal silver nitrate forms a white precipitate easily with**

**Options:**

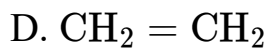
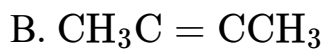
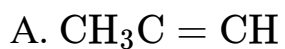



**Answer: A**

## Solution:

In general,  $C_2H_2$  and all 1-alkynes give white precipitate with ammoniacal silver nitrate. Thus, in this question, propyne-1 ( $CH_3C \equiv CH$ ) will give white precipitate with ammoniacal silver nitrate.

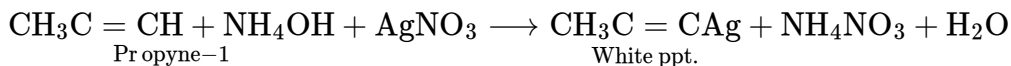

## Question 70

Consider the following equilibrium,

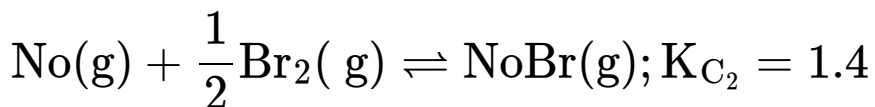
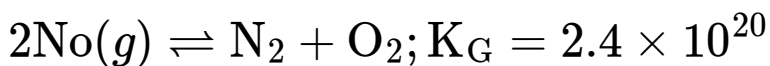

Calculate  $K_C$  for the reaction,

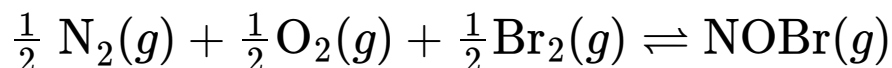

Options:

A.  $8.96 \times 10^{-11}$

B.  $9.48 \times 10^{-9}$

C.  $8.08 \times 10^{-12}$

D.  $8.96 \times 10^{11}$

**Answer: A**

## Solution:

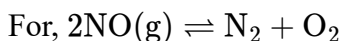

$$K_{C_1} = \frac{[N_2][O_2]}{[NO]^2} = 2.4 \times 10^{20}$$

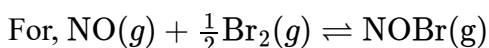

$$K_{C_2} = \frac{[\text{NOBr}]}{[\text{NO}][\text{Br}_2]^{1/2}} = 1.4$$

$$\text{and } K_C = \frac{[\text{NOBr}]}{[\text{N}_2]^{1/2}[\text{O}_2]^{1/2}[\text{Br}_2]^{1/2}}$$

$$\text{or } K_C = \sqrt{\frac{1}{K_{C_1}}} \times K_{C_2} = \sqrt{\frac{1}{2.4 \times 10^{20}}} \times 1.4$$

$$K_C = 8.96 \times 10^{-11}$$

---

## Question 71

Which of the following is incorrect regarding Henry's law?

Options:

- A. Gas reacts with solvent chemically.
- B. Pressure and concentrations are not too high.
- C. Temperature is not too low.
- D. Gas does not change its molecular state in solution i.e., neither dissociates nor associates.

**Answer: A**

**Solution:**

Most of the gases obey Henry's law when gases do not react with solvent chemically.

---

## Question 72

*t*-butyl chloride preferably undergo hydrolysis by

Options:

- A. S<sub>N</sub>1 mechanism
- B. S<sub>N</sub>2 mechanism

C. any of (a) and (b)

D. None of the above

**Answer: A**

**Solution:**

Tertiary halide preferentially undergo  $S_N1$  substitution as they can give stable carbocation.

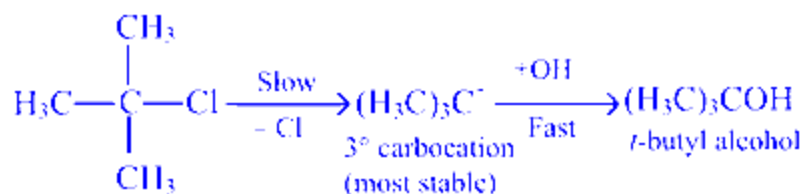

## Question 73

Which of these represents the correct order of decreasing bond order?

**Options:**

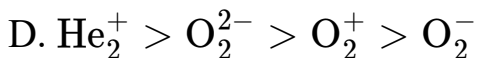
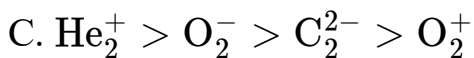
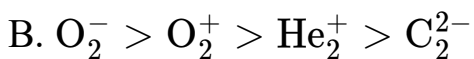
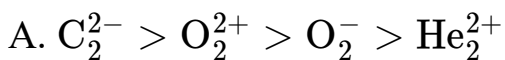

**Answer: A**

**Solution:**

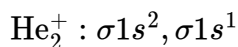

$$\text{BO} = \frac{1}{2}(N_b - N_a) = \frac{1}{2}(2 - 1) = \frac{1}{2} = 0.5$$

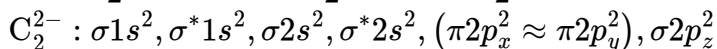

$$\text{BO} = \frac{1}{2}(10 - 4) = \frac{6}{2} = 3.0$$

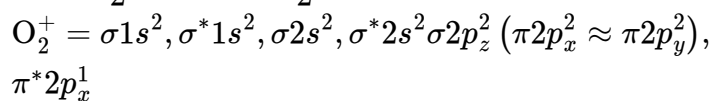

$$\text{O}_2^- = \frac{1}{2}(10 - 5) = \frac{5}{2} = 2.5$$

$$\text{BO} = \frac{1}{2}(10 - 7) = \frac{3}{2} = 1.5$$

Thus, the correct order of decreasing bond order is

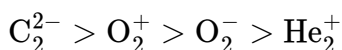

## Question 74

In a 0.2 M aqueous solution, lactic acid is 6.9% dissociated. The value of dissociation constant is

Options:

A.  $1.2 \times 10^{-4}$

B.  $9.5 \times 10^{-4}$

C.  $6.5 \times 10^{-4}$

D.  $3.6 \times 10^{-2}$

**Answer: B**

**Solution:**

Given,  $\alpha = 6.9\%$

$\therefore$  Degree of dissociation,

$$\alpha = \frac{6.9}{100}$$

$$\alpha = 0.069$$

According to Ostwald's dilution law,

$$K_a = \alpha^2 C = (0.069)^2 \times 0.2$$

$$K_a = 9.5 \times 10^{-4}$$

---

## Question 75

**Pick up the correct statement.**

**Options:**

- A. Dipole moment of ammonia is due to orbital dipole and resultant dipole in same direction.
- B.  $O_2$ ,  $H_2$  shown bond dipole due to polarisation.
- C. Dipole moment is scalar quantity.
- D. In  $BF_3$  bond dipoles are zero but dipole moment is higher.

**Answer: A**

**Solution:**

Option (a) is the correct option.

In ammonia,

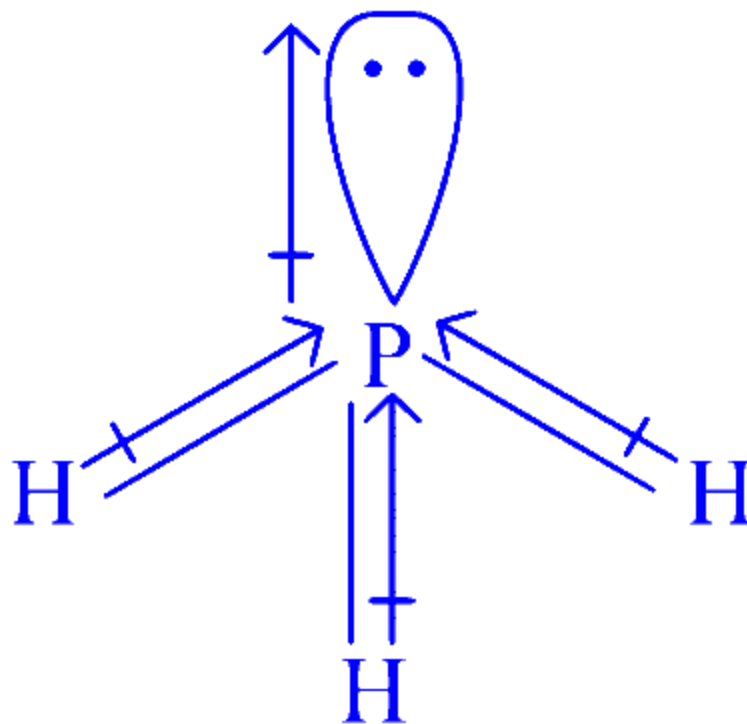

As, nitrogen is more electronegative than hydrogen, the resultant dipole moment adds up in the same direction.

Dipole moment is a vector quantity.

O<sub>2</sub> and H<sub>2</sub> are homoatomic molecules thus, show no dipole.

---

## Question 76

**Total number of  $\sigma$  and  $\pi$  bonds in ethene molecule is**

**Options:**

- A. 1 $\sigma$  and 2 $\pi$  bonds
- B. 5 $\sigma$  and 1 $\pi$  bonds
- C. 5 $\sigma$  and 2 $\pi$  bonds
- D. 3 $\sigma$  and 1 $\pi$  bonds

**Answer: B**

**Solution:**

In ethene,

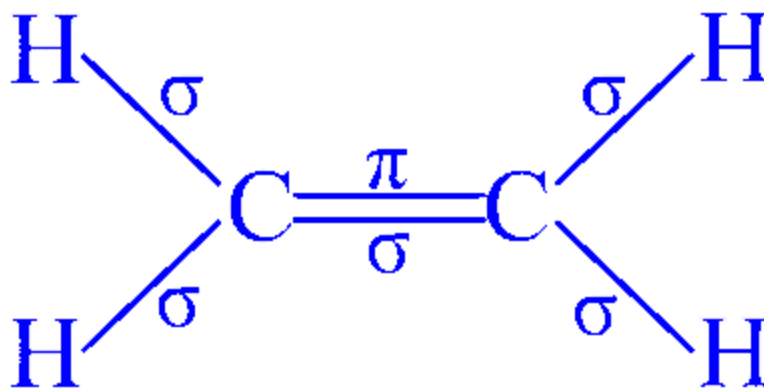

5σ-bond and 1π-bond.

---

## Question 77

A buffer solution has equal volumes of 0.1 M  $\text{NH}_4\text{OH}$  and 0.01 M  $\text{NH}_4\text{Cl}$ . The  $\text{p}K_b$  of the base is 5. The pH is

Options:

- A. 10
- B. 9
- C. 4
- D. 7

**Answer: A**

**Solution:**

$$\begin{aligned} \text{pOH} &= \text{p}K_b + \log \frac{[\text{Salt}]}{[\text{Base}]} \\ &= 5 + \log \frac{0.01}{0.01} = 5 + \log \frac{1}{10} = 5 + (-1) = 4 \\ \text{pH} &= 14 - \text{pOH} = 14 - 4 = 10 \end{aligned}$$

---

## Question 78

**Assuming no change in volume, the time required to obtain solution of pH = 4 by electrolysis of 100 mL of 0.1 M NaOH (using current 0.5 A ) will be**

**Options:**

A. 1.93 s

B. 2.63 s

C. 1.80 s

D. 4.26 s

**Answer: A**

**Solution:**

$$[\text{H}^+] = 10^{-4}\text{M}$$

No. of moles of NaOH in 100 mL solution

$$= \frac{MV}{1000} = \frac{10^{-4} \times 100}{1000} = 10^{-5}$$

$$\text{Mass of NaOH in solution} = 10^{-5} \times 40 = 4 \times 10^{-4} \text{ g}$$

By Faraday's law,

$$W = \frac{ItE}{96500}$$

$$\text{or } 4 \times 10^{-4} = \frac{0.5 \times t \times 40}{96500}$$

$$t = \frac{4 \times 10^{-4} \times 96500}{0.5 \times 40} = 1.93 \text{ s}$$

---

## Question 79

**Which of the following compounds would not be expected to decarboxylate when heated?**

**Options:**

A.



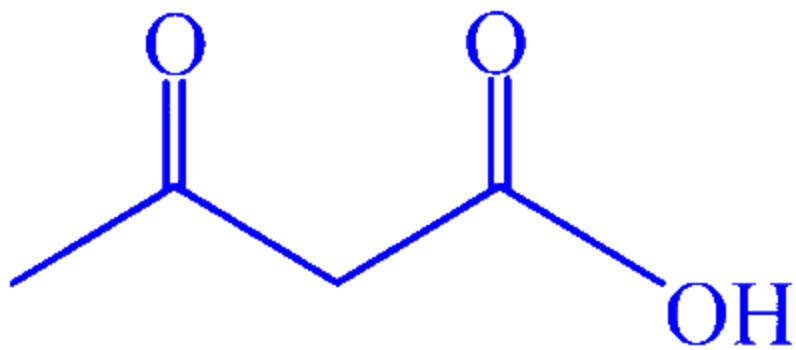

B.

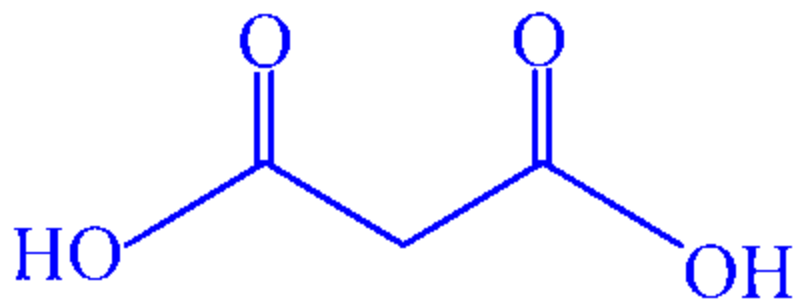

C.

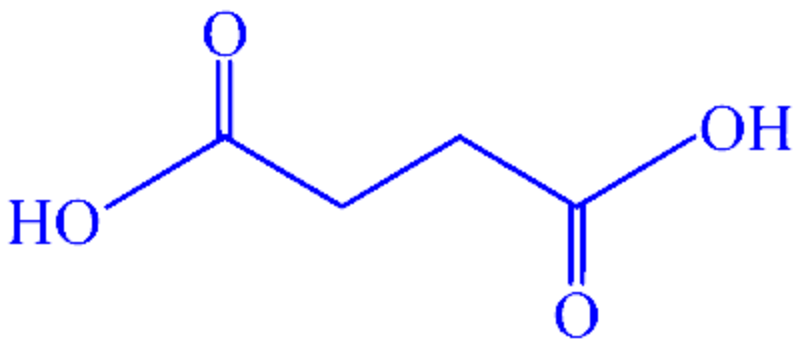

D.

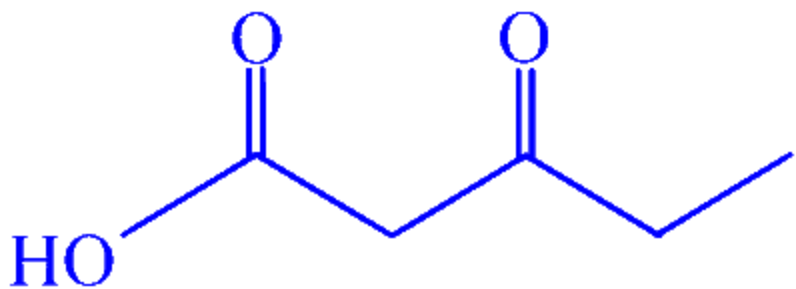

**Answer: C**

**Solution:**

Gem dicarboxylic acid like

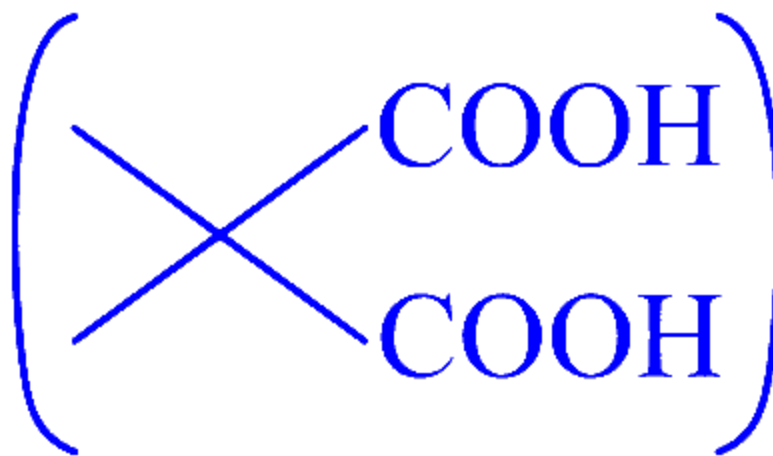

or an acid having a keto group at  $\beta$ -position is decarboxylated on heating.

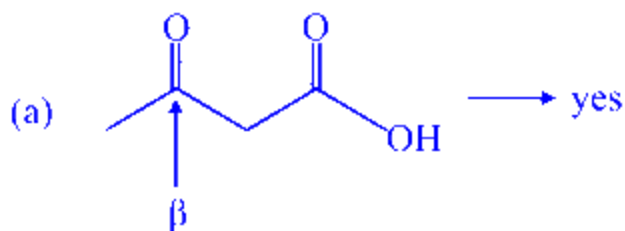

(b) yes

(c) no

(d) yes

## Question 80

Which of these molecules have non-bonding electron pairs on the central atom?

I :  $\text{SF}_4$  : II :  $\text{ICl}_3$  : III :  $\text{SO}_2$

Options:

A. II only

B. I and II only

C. I and III only

D. I, II and III

**Answer: D**

**Solution:**

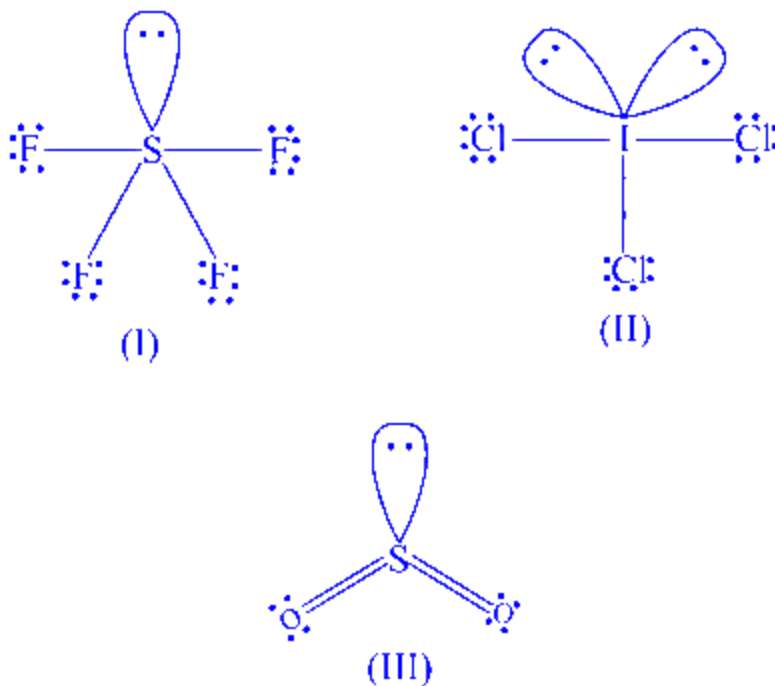

(I), (II) and (III) all of them have non-bonding electron (lone pair) on the central atom.

---

## Question 81

For a cell reaction,  $A(s) + B^{2+}(aq) \longrightarrow A^{2+}(aq) + B(s)$ ; the standard emf of the cell is 0.295 V at  $25^\circ\text{C}$ . The equilibrium constant at  $25^\circ\text{C}$  will be

Options:

- A.  $1 \times 10^{10}$
- B. 10
- C.  $2.95 \times 10^{-2}$
- D.  $2.95 \times 10^{-10}$

**Answer: A**

**Solution:**

For this given reaction,  $n = 2$ . At  $25^\circ\text{C}$ ,

$$\therefore K = \text{antilog} \left[ \frac{nE^\circ}{0.059} \right] = \text{antilog} \left[ \frac{2 \times (-0.295)}{0.059} \right]$$
$$K = 1 \times 10^{10}$$

---

## Question 82

**Which of the following shows negative deviation from Raoult's law?**

**Options:**

- A. Benzene-acetone
- B. Benzene-chloroform
- C. Benzene-ethanol
- D. Benzene-carbon tetrachloride

**Answer: B**

**Solution:**

Negative deviation from Raoult's law are noticed when solvent-solvent and solute-solute interactions are weaker than solute-solvent interactions. In such solutions, the mixing of two components leads to the strengthening of intermolecular attractions and thus results in lesser values of vapour pressure of solution.

$\therefore$  Benzene-chloroform mixtures shows negative deviation.

---

## Question 83

**5 g of non-volatile water soluble compound  $X$  is dissolved in 100 g of water. The elevation in boiling point is found to be 0.25. The molecular mass of compound  $X$  is**

**Options:**

- A. 35 g
- B. 40 g

C. 20 g

D. 60 g

**Answer: C**

**Solution:**

The elevation in boiling point is,

$$\Delta T_b = \frac{1000k_b \times w_2}{M_2 \times w_1(\text{ in (g)})} \Rightarrow M_2 = \frac{1000 \times k_b \times 5}{0.25 \times 100}$$
$$\Rightarrow M_2 = 20 \text{ g}$$

---

## Question 84

**The correct decreasing order of negative electron gain enthalpy for C, Ca, Al, F and O is**

**Options:**

A.  $F > O > C > Al > Ca$

B.  $Ca > Al > O > F > C$

C.  $Al > F > Ca > C > O$

D.  $F > C > O > Ca > Al$

**Answer: A**

**Solution:**

Electron gain enthalpy (EGE) is the amount of energy released when an electron is added to a neutral atom in the gaseous state to form a negative ion. For non-metallic elements, EGE is typically more negative, reflecting the energy released when these elements gain electrons to attain a stable electronic configuration.

Fluorine (F) is the most electronegative element, which means it has a very high propensity to gain electrons, resulting in the most negative EGE. Oxygen (O), being close to fluorine in the periodic table and also very electronegative, has the next most negative EGE. Carbon (C), a non-metal located in the same period as oxygen, has a less negative EGE than oxygen but still more negative than the metals. Aluminium (Al) and Calcium (Ca) are metals and tend to lose electrons; thus, their EGE values are less negative than those of the non-metals listed.

Thus, the correct decreasing order of negative EGE for the given elements is:  $F > O > C > Al > Ca$ .

---

## Question 85

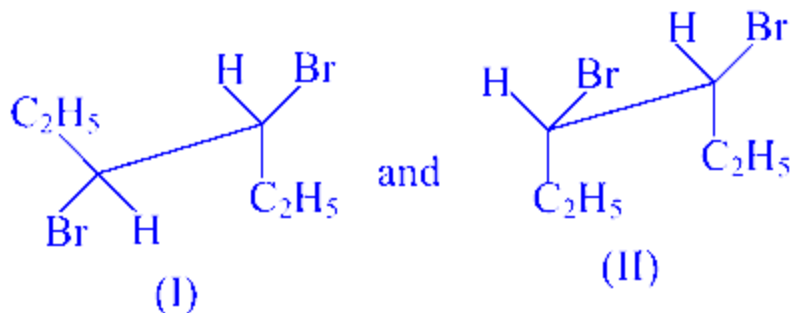

I and II are

Options:

- A. identical
- B. a pair of conformers
- C. a pair of geometrical isomers
- D. a pair of optical isomers

**Answer: B**

**Solution:**

I and II are staggered and eclipsed conformers.

---

## Question 86

$\text{Ti}^{2+}$  is purple while  $\text{Ti}^{4+}$  is colourless because

Options:

- A.  $\text{Ti}^{2+}$  has  $3d^2$  configuration
- B.  $\text{Ti}^{4+}$  has  $3d^2$  configuration

C.  $\text{Ti}^{2+}$  is very small cation when compared to  $\text{Ti}^{4+}$  and hence, doesn't absorb any radiation

D. There is no crystal field effect in  $\text{Ti}^{4+}$

**Answer: A**

**Solution:**

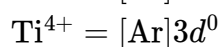
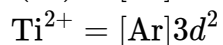
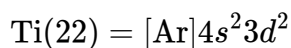

$\text{Ti}^{2+}$  has two unpaired electrons in  $3d$  orbital and hence  $d-d$  transition is possible due to absorption of light in visible region whereas  $\text{Ti}^{4+}$  is diamagnetic hence colourless.

---

## Question 87

**In Friedal-Crafts alkylation reaction of phenol with chloromethane, the product formed will be**

**Options:**

A. *p*-cresol only

B. *m*-cresol only

C. mixture of *o*-and *p*-cresol

D. *o*-cresol only

**Answer: C**

**Solution:**

The reaction is represented as

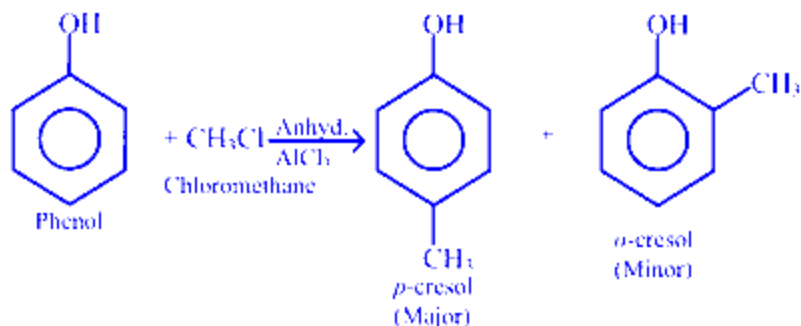

## Question 88

Which among the following is diamagnetic?

Options:

- A. [Ni(CN)<sub>4</sub>]<sup>2-</sup>
- B. [Co (F<sub>6</sub>)]<sup>3-</sup>
- C. [NiCl<sub>4</sub>]<sup>2-</sup>
- D. [Fe(CN)<sub>6</sub>]<sup>3-</sup>

**Answer: A**

**Solution:**

In [Ni(CN)<sub>4</sub>]<sup>2-</sup> CN<sup>-</sup> is strong field ligand and causes pairing of electrons.

$\therefore \text{Ni}^{2+} = 3d^8$   
[Ni(CN)<sub>4</sub>]<sup>2-</sup>

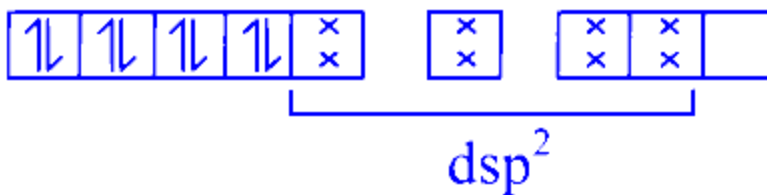

As, all the electrons are paired, hence, it is diamagnetic.



## Question 89

Which one of the following is an important component of chlorophyll?

Options:

- A. Mn
- B. Mg
- C. Fe
- D. Zn

**Answer: B**

**Solution:**

Magnesium is an important structural component of chlorophyll molecules. It is present in the tetrapyrrole ring of chlorophyll in its centre.

-----

## Question 90

A volatile compound is formed by carbon monoxide and

Options:

- A. Cu
- B. Al
- C. Ni
- D. Si

**Answer: C**

**Solution:**

Nickel on heating in a steam of carbon monoxide forms a volatile complex nickel tetracarbonyl.

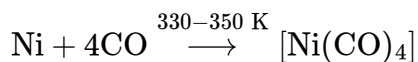

## Question 91

The complex  $[\text{PtCl}_2(\text{en})_2]^{2+}$  ion shows

Options:

- A. structural isomerism
- B. geometrical isomerism only
- C. optical isomerism only
- D. geometrical and optical isomerism

**Answer: D**

**Solution:**

$[\text{PtCl}_2(\text{en})_2]^{2+}$  shows both geometrical and optical isomerism as the complex forms cis and trans isomers. trans-isomer doesn't show optical isomerism since it is symmetrical but cis-isomer shows optical isomerism as it is unsymmetrical.

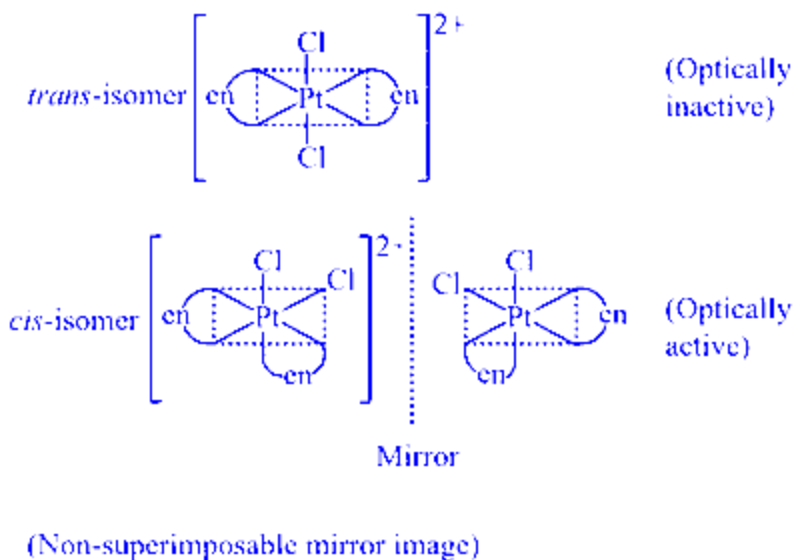

## Question 92

**15 g of  $\text{CaCO}_3$  completely reacts with**

**Options:**

- A. 6.95 g of HCl
- B. 10.95 g of HCl
- C. 11.95 g of HCl
- D. 1.15 g of HCl

**Answer: B**

**Solution:**

The balanced equation the reaction is

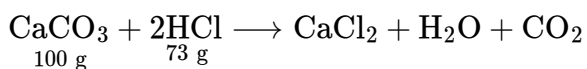

100 g of  $\text{CaCO}_3$  completely reacts with 73 g of HCl

$$\begin{aligned} \text{So, 15 g of } \text{CaCO}_3 \text{ will react with} &= \frac{73}{100} \times 15 \text{ g of HCl} \\ &= 10.95 \text{ g of HCl} \end{aligned}$$

---

## Question 93

**Bohr's radius of 2 nd orbit of  $\text{Be}^{3+}$  is equal to that of**

**Options:**

- A. 4th orbit of hydrogen
- B. 2nd orbit of  $\text{He}^+$
- C. 3rd orbit of  $\text{Li}^{2+}$
- D. 1st orbit of hydrogen

**Answer: D**

## Solution:

Bohr radius for  $n$ th orbit =  $0.53\overset{\circ}{\text{A}} \times \frac{n^2}{Z}$  where,  $Z$  = atomic number

$\therefore$  Bohr radius of 2nd orbit of

$$\text{Be}^{3+} = \frac{0.53 \times (2)^2}{4} = 0.53\overset{\circ}{\text{A}}$$

For option (d) Bohr radius of 1st orbit of

$$\text{H} = \frac{0.53 \times (1)^2}{1} = 0.53\overset{\circ}{\text{A}}$$

Hence, Bohr's radius of 2nd orbit of  $\text{Be}^{3+}$  is equal to that of first orbit of hydrogen.

---

## Question 94

**How much faster would a reaction proceed at  $25^\circ\text{C}$  than at  $0^\circ\text{C}$  if the activation energy is 65 kJ?**

**Options:**

- A. 4 times
- B. 6 times
- C. 12 times
- D. 11 times

**Answer: D**

**Solution:**

We know,

$$2.303 \log \frac{k_2}{k_1} = \frac{E_a}{R} \left[ \frac{T_2 - T_1}{T_1 T_2} \right]$$
$$\therefore 2.303 \log \frac{k_2}{k_1} = \frac{65 \times 10^3}{8.314} \left[ \frac{25}{298 \times 273} \right]$$
$$\frac{k_2}{k_1} = 11.5.$$

$\therefore$  The reaction would proceed 11 times faster.

---

## Question 95

The blue colouration obtained from the Lassaigne's test of nitrogen is due to the formation of

Options:

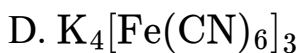
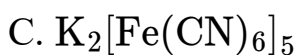
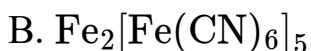
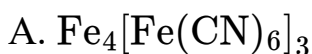

Answer: A

Solution:

The blue colouration is due to the formation of  $\text{Fe}_4[\text{Fe}(\text{CN})_6]_3$  (ferriferrocyanide).

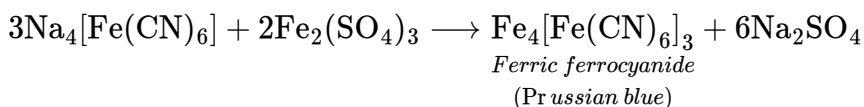
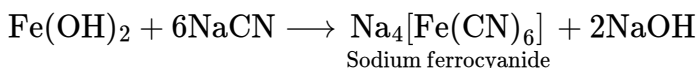

---

## Question 96

The ion that is isoelectronic with CO is

Options:

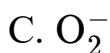

D.  $\text{N}_2^+$

**Answer: B**

**Solution:**

$\text{CN}^-$  is isoelectronic to CO as they have same number of electrons.

Number of electrons in the given species is as follows,

$$\text{CO} = 6 + 8 = 14$$

$$\text{O}_2^- = 16 + 1 = 17$$

$$\text{N}_2^+ = 14 - 1 = 13$$

$$\text{O}_2^+ = 16 - 1 = 15$$

$$\text{CN}^- = 6 + 7 + 1 = 14$$

---

## Question 97

**At 300 K, the half-life period of a gaseous reaction at an initial pressure of 40 kPa is 350 s. When pressure is 20 kPa, the half-life period is 175 s. What is the order of the reaction?**

**Options:**

A. Three

B. Two

C. One

D. Zero

**Answer: D**

**Solution:**

We know that

$$\frac{(t_{1/2})_1}{(t_{1/2})_2} = \left(\frac{p_2}{p_1}\right)^{n-1}$$

where,  $n$  is the order of reaction and  $t_{1/2}$  is half-life.

$$\frac{350}{175} = \left(\frac{20}{40}\right)^{n-1}$$

$$\text{or } 2 = \left(\frac{1}{2}\right)^{n-1}$$

$$\Rightarrow n - 1 = -1$$

$$n = 0$$

∴ It is a zero order reaction.

---

## Question 98

If 2 moles of  $\text{C}_6\text{H}_6(\text{g})$  are completely burnt 4100 kJ of heat is liberated. If  $\Delta H^\circ$  for  $\text{CO}_2(\text{g})$  and  $\text{H}_2\text{O}(\text{l})$  are  $-410$  and  $-285$  kJ per mole respectively then the heat of formation of  $\text{C}_2\text{H}_6(\text{g})$  is

Options:

A.  $-116$  kJ

B.  $-375$  kJ

C.  $-775$  kJ

D.  $-885$  kJ

**Answer: B**

**Solution:**

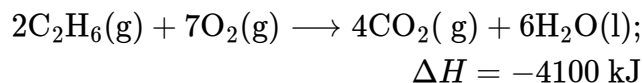

Let,  $\Delta H_f^\circ(\text{C}_2\text{H}_6) = x$ ,

$$\Delta H = \sum H_{f(\text{products})}^\circ - \sum H_{f(\text{reactants})}^\circ$$
$$-4100 = [4(-410) + 6(-285)] - [2x + 0]$$
$$x = -375 \text{ kJ}$$

---

## Question 99

**Abnormal colligative properties are observed only when the dissolved non-volatile solute in a given dilute solution**

**Options:**

- A. is a non-electrolyte
- B. offers an intense colour
- C. associates and dissociates
- D. offers no colour

**Answer: C**

**Solution:**

As the colligative properties depend only upon the number of particles of solute, so if the non-volatile solute dissociates or associates in the solution, the value of colligative properties deviates i.e., abnormal colligative properties are obtained.

---

## **Question 100**

**Aqueous  $\text{CuSO}_4$  changes its colour from sky blue to deep blue on addition of  $\text{NH}_3$  because**

**Options:**

- A.  $\text{Cu}^{2+}$  forms hydrate
- B.  $\text{Cu}^{2+}$  changes to  $\text{Cu}^+$
- C.  $[\text{Cu}(\text{H}_2\text{O})_4]^{2+}$  is labile complex and changes to  $[\text{Cu}(\text{NH}_3)_4]^{2+}$  as  $\text{NH}_3$  is stronger ligand than  $\text{H}_2\text{O}$
- D.  $\text{Cu}^+$  changes to  $\text{Cu}^{2+}$

**Answer: C**

**Solution:**



As,  $\text{H}_2\text{O}$  is a weak field ligand and thus  $[\text{Cu}(\text{H}_2\text{O})_4]^{2+}$  absorbs red light in visible spectrum. But the colour appears blue because  $[\text{Cu}(\text{H}_2\text{O})_4]^{2+}$  is a labile complex and changes to  $[\text{Cu}(\text{NH}_3)_4]^{2+}$ , where  $\text{NH}_3$  is strong field ligand thus absorbs yellow light of visible spectrum and impart blue colour.

---

## Question 101

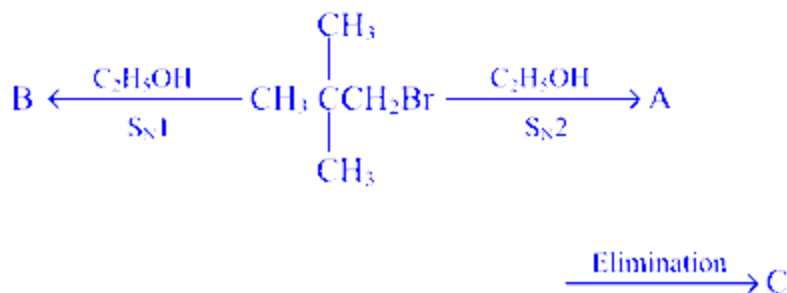

Identify A, B and C.

Options:

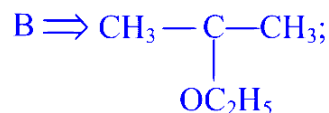
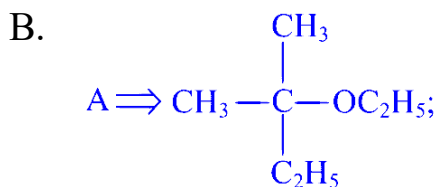
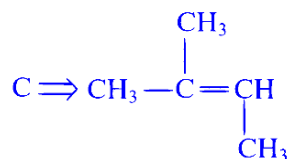
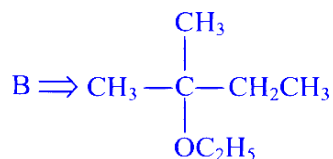
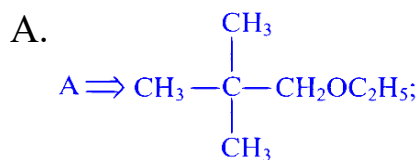

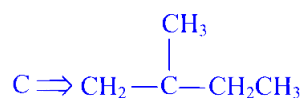
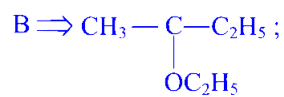
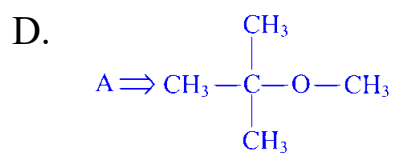
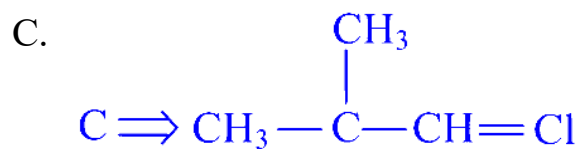

**Answer: A**

**Solution:**

For  $S_N1$  reaction, the stable carbocation formation leads to stable product thus, there is 1, 2-methyl shift.

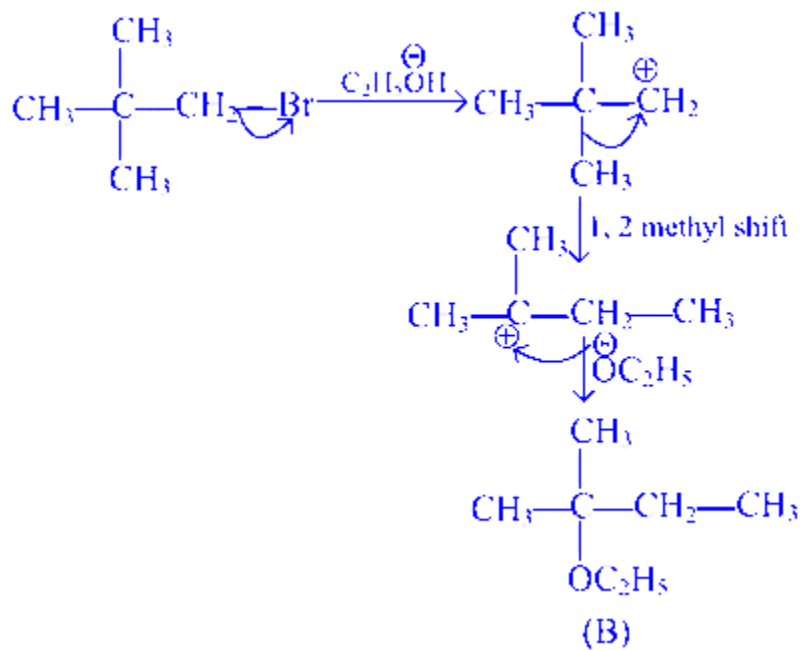

- For  $S_N2$  reaction, direct attack occurs, thus no rearrangement occurs in the reaction.

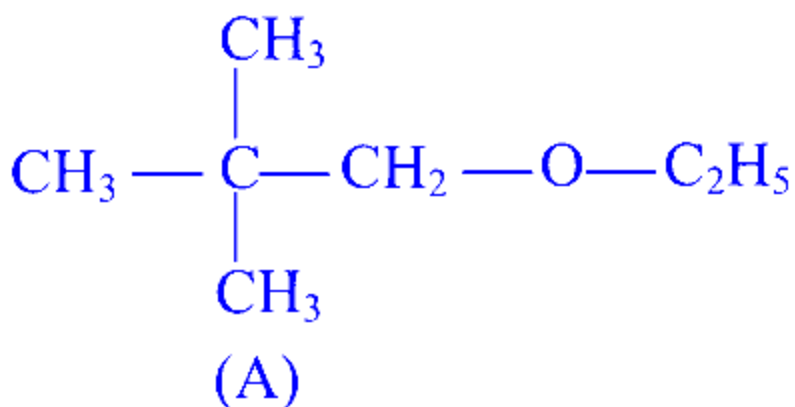

- For elimination, more stable alkene is formed.

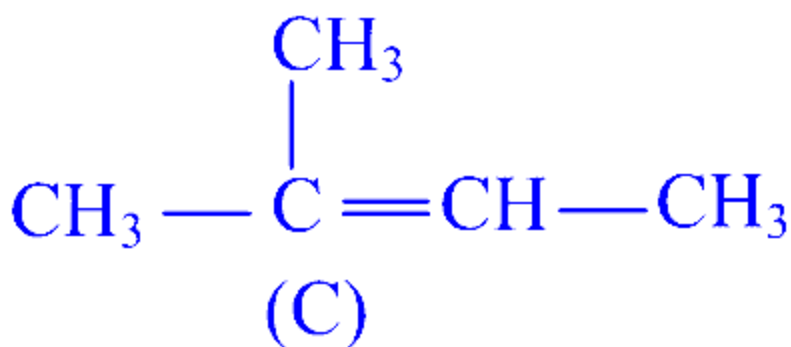

---

## Question 102

For a reaction,  $2A + B \longrightarrow$  products, If concentration of  $B$  is kept constant and concentration of  $A$  is doubled then rate of reaction is

Options:

- A. doubled
- B. quadrupled
- C. halved
- D. remain same

**Answer: B**

**Solution:**

The rate of reaction for



If concentration of A is doubled,

$$\text{Rate}' = [2A]^2[B] = 4k[A]^2[B]$$

$$\text{Rate}' = 4 \text{ Rate}$$

---

## Question 103

**For an adiabatic change in a system, the condition which is applicable is**

**Options:**

A.  $q = 0$

B.  $w = 0$

C.  $q = -w$

D.  $q = w$

**Answer: A**

**Solution:**

There is no heat exchange between the system and the surrounding for adiabatic change.

$$\therefore q = 0$$

---

## Question 104

**In dilute alkaline solution  $\text{MnO}_4^-$  changes to**

**Options:**





**Answer: B**

**Solution:**

In strong base,

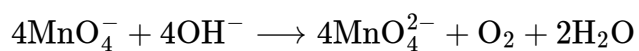

## Question 105

**Which of the following complex show optical isomerism?**

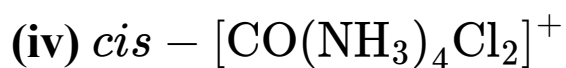
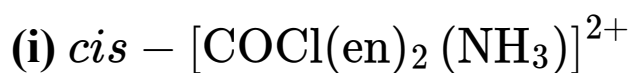

**Options:**

A. (i), (ii), (iii)

B. (i), (ii)

C. (i), (iv)

D. (i), (ii), (iv)

**Answer: A**

**Solution:**

Octahedral complex having general formula  $[M(AA)_2a_2]^{n\pm}$  or  $[M(AA)_2ab]^{n\pm}$ , shows optical isomerism.

*cis* -  $[\text{Co}(\text{NH}_3)_4\text{Cl}_2]^+$  does not show optical isomerism due to symmetry, while other three complexes show optical isomerism.

---

## Question 106

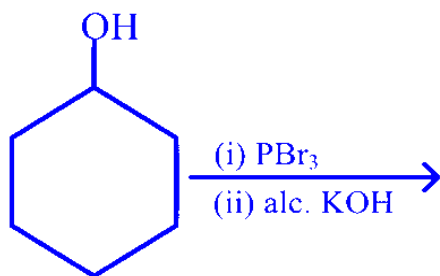

Options:

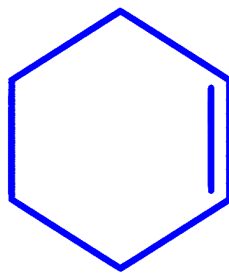
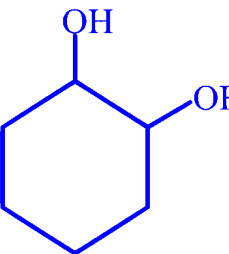
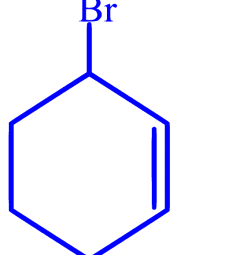
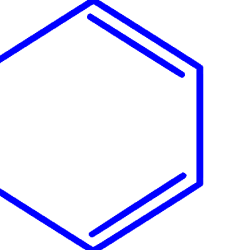
- A. 
- B. 
- C. 
- D. 

**Answer: A**

**Solution:**

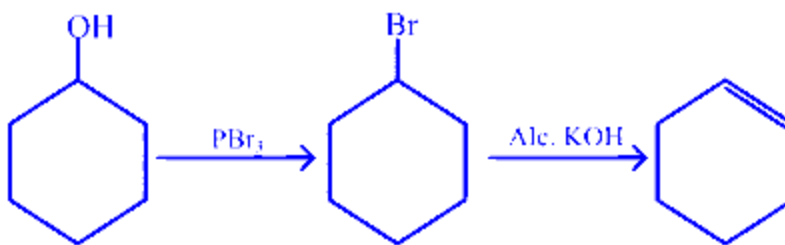

---

## Question 107

**Mohr's salt has the formula**

**Options:**

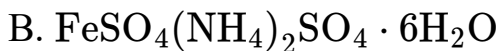

**Answer: B**

**Solution:**

When  $\text{FeSO}_4 \cdot 7\text{H}_2\text{O}$  reacts with  $(\text{NH}_4)_2\text{SO}_4$ , it forms a double salt known as ferrous ammonium sulphate ( $\text{FeSO}_4(\text{NH}_4)_2\text{SO}_4 \cdot 6\text{H}_2\text{O}$ ) or Mohr's salt.

---

# Physics

## Question 108

The mean energy per molecule for a diatomic gas is

Options:

A.  $\frac{5k_B T}{N}$

B.  $\frac{5k_B T}{2N}$

C.  $\frac{5k_B T}{2}$

D.  $\frac{3k_B T}{2}$

**Answer: C**

**Solution:**

For an ideal gas, mean kinetic energy per molecule

$$= \frac{f}{2} k_B T$$

For diatomic gas, degree of freedom,

$$f = 5$$

$$\therefore \text{K.E per molecule} = \frac{5k_B T}{2}$$

---

## Question 109

The phase difference between displacement and velocity of a particle in simple harmonic motion is

Options:



- A.  $\pi$  rad
- B.  $3\pi/2$  rad
- C. zero
- D.  $\pi/2$  rad

**Answer: D**

**Solution:**

The displacement of a particle executing SHM is  $x = A \sin \omega t$

$$\therefore \text{Velocity, } v = \frac{dx}{dt} = A\omega \cos \omega t$$

$$\therefore v = A\omega \sin \left( \omega t + \frac{\pi}{2} \right)$$

$$\therefore \text{Phase difference, } \Delta\phi = \left( \omega t + \frac{\pi}{2} \right) - \omega t = \frac{\pi}{2} \text{ rad.}$$

---

## Question 110

**The mass density of a nucleus varies with mass number  $A$  as**

**Options:**

- A.  $A^0$
- B.  $A^2$
- C.  $\frac{1}{A}$
- D.  $\ln A$

**Answer: A**

**Solution:**

As, the mass density of a nucleus is constant

$$\therefore \text{Mass density, } = \frac{3m}{4\pi R_0^3}$$

---

## Question 111

A capacitor of capacity  $2 \mu\text{F}$  is charged upto a potential  $14 \text{ V}$  and then connected in parallel to an uncharged capacitor of capacity  $5 \mu\text{F}$ . The final potential difference across each capacitor will be

Options:

- A.  $6 \text{ V}$
- B.  $4 \text{ V}$
- C.  $8 \text{ V}$
- D.  $14 \text{ V}$

**Answer: B**

**Solution:**

When two capacitors are connected then their common potential difference is

$$V = \frac{C_1 V_1 + C_2 V_2}{C_1 + C_2}$$

Given,  $C_1 = 2 \mu\text{F}$ ,  $V_1 = 14 \text{ V}$ ,  $C_2 = 5 \mu\text{F}$ ,  $V_2 = 0 \text{ V}$

$$\therefore V = \frac{2 \times 14 + 5 \times 0}{2 + 5} = 4 \text{ V}$$

---

## Question 112

The ratio of amplitude of magnetic field to the amplitude of electric field of an electromagnetic wave propagating in vacuum is

Options:

- A. reciprocal of speed of light in vacuum
- B. the speed of light in vacuum

C. proportional to frequency of the electromagnetic wave

D. inversely proportional to the frequency of the electromagnetic wave

**Answer: A**

**Solution:**

For an electromagnetic wave, Speed of electromagnetic wave,  $c = \frac{E_0}{B_0}$

$\therefore \frac{B_0}{E_0} = \frac{1}{c} = \text{reciprocal of speed}$

---

## Question 113

**A particle is projected at an angle  $30^\circ$  with horizontal having kinetic energy  $K$ . The kinetic energy of the particle at highest point is.**

**Options:**

A.  $\frac{1}{2}K$

B.  $\frac{3}{4}K$

C.  $\frac{3}{8}K$

D.  $\frac{5}{8}K$

**Answer: B**

**Solution:**

Initial kinetic energy is

$$K = \frac{1}{2}mv^2 \quad \dots (i)$$

Final kinetic energy is

$$\begin{aligned} K' &= \frac{1}{2}mv^2 = \frac{1}{2}m(u \cos 30^\circ)^2 && [\because v = u \cos 30^\circ] \\ &= \frac{3}{4} \left( \frac{1}{2}mu^2 \right) = \frac{3}{4}K && [\text{From Eq. (i)}] \end{aligned}$$

---

## Question 114

An air bubble in water ( $\mu = \frac{4}{3}$ ) is shown in figure. The apparent depth of the image of the bubble in plane mirror viewed by observer is.

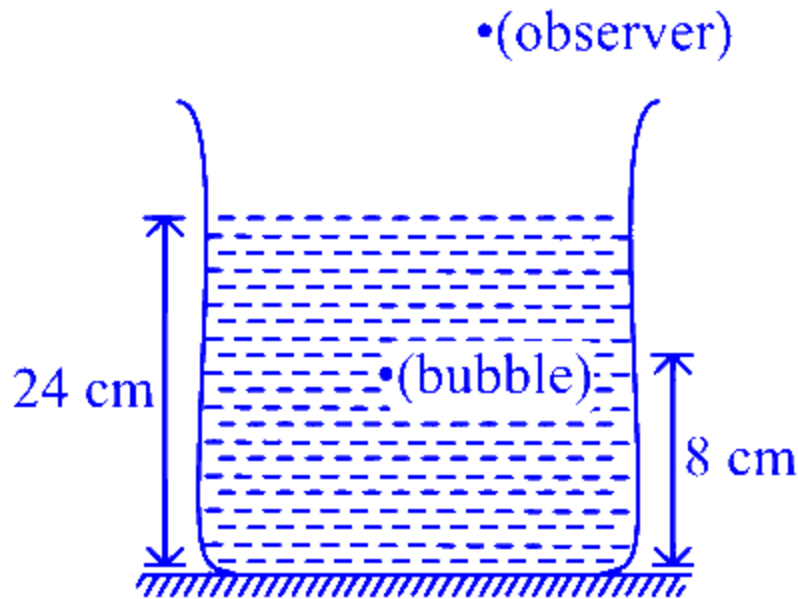

**Options:**

- A. 16 cm
- B. 18 cm
- C. 24 cm
- D. 12 cm

**Answer: C**

**Solution:**

The refractive index of water,

$$\mu = \frac{4}{3}$$

The real depth of image of bubble from the surface of water,

$$d = 24 + 8 = 32 \text{ cm}$$

∴ Apparent depth of the image of bubble is

$$d' = \frac{d}{\mu} = \frac{32}{4/3} = 24 \text{ cm}$$

---

## Question 115

**A transistor is connected in CE configuration. The collector supply is 10 V and the voltage drop across a resistor of  $1000\Omega$  in the collector circuit is 0.5 V. If the current gain factor is 0.96, then the base current is**

**Options:**

A.  $256\mu\text{A}$

B.  $20.8\mu\text{A}$

C.  $22.5\mu\text{A}$

D.  $15\mu\text{A}$

**Answer: B**

**Solution:**

Current gain factor,  $\alpha = 0.96$

$R = 1000\Omega$ , Voltage drop across collector resistor = 0.5 V

$$\therefore \beta = \frac{\alpha}{1-\alpha} = \frac{0.96}{1-0.96} = 24$$

∴ Collector current,

$$i_c = \frac{\text{Voltage drop across collector resistor}}{R}$$

$$= \frac{0.5}{1000} = 0.5 \times 10^{-3} \text{ A}$$

$$\text{The base current, } i_b = \frac{i_c}{\beta} = \frac{0.5 \times 10^{-3}}{24} = 20.8\mu\text{A}$$

---

## Question 116

One end of the string of length  $l$  is connected to a particle of mass  $m$  and the other end is connected to a small peg on a smooth horizontal table. If the particle moves in circle with speed  $v$ , the net force on the particle (directed towards centre) will be ( $T$  represents the tension in the string)

Options:

A.  $T$

B.  $T + \frac{mv^2}{l}$

C.  $T - \frac{mv^2}{l}$

D. zero

Answer: A

Solution:

Consider the string of length  $l$  connected to a particle as shown in the figure

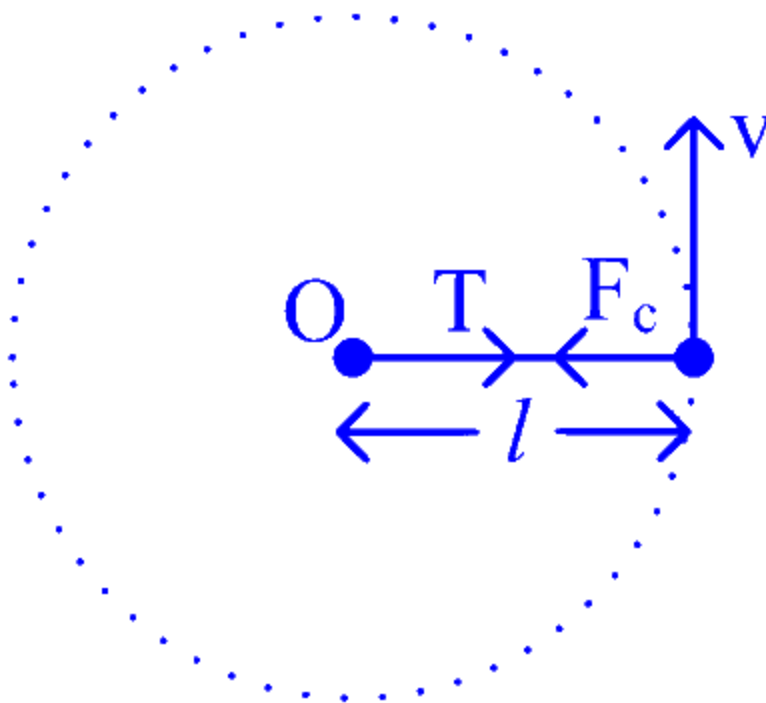

Speed of the particle is  $v$ . As, the particle is in uniform circular motion, the net force on the particle must be equal to centripetal force which is provided by the tension ( $T$ ).

$\therefore$  Net force = Centripetal force  
= Tension in string

$$\Rightarrow \frac{mv^2}{l} = T$$

---

## Question 117

A thin circular ring of mass  $M$  and radius  $R$  rotates about an axis through its centre and perpendicular to its plane, with a constant angular velocity  $\omega$ . Four small spheres each of mass  $m$  (negligible radius) are kept gently to the opposite ends of two mutually perpendicular diameters of the ring. The new angular velocity of the ring will be

Options:

A.  $\left(\frac{M+4m}{M}\right)\omega$

B.  $\frac{M}{4m}\omega$

C.  $\left(\frac{M}{M+4m}\right)\omega$

D.  $\left(\frac{M}{M-4m}\right)\omega$

**Answer: C**

**Solution:**

According to conservation of angular momentum,

$$I\omega = \text{constant}$$

i.e. we can write,

$$I_1\omega_1 = I_2\omega_2$$

$$\text{or } MR^2\omega = (M + 4m)R^2\omega_2 \quad (\because \omega_1 = \omega)$$

$$\text{or } \omega_2 = \left(\frac{M}{M + 4m}\right)\omega$$

---

# Question 118

Two wire of same material having radius in ratio 2 : 1 and lengths in ratio 1: 2. If same force is applied on them, then ratio of their change in length will be

Options:

A. 1 : 1

B. 1 : 2

C. 1 : 4

D. 1 : 8

**Answer: D**

**Solution:**

Given, ratio of radius of two wires,

$$\frac{r_1}{r_2} = \frac{2}{1}$$

and ratio in their lengths,

$$\frac{l_1}{l_2} = \frac{1}{2}$$

When same force is applied on them, then ratio change in their lengths,

$$\frac{\Delta l_1}{\Delta l_2} = ?$$

We know that, Young's modulus,

$$Y = \frac{Fl}{A\Delta l} \Rightarrow \Delta l = \frac{Fl}{AY}$$

$$\Delta l \propto \frac{l}{A}$$

$$\therefore \frac{\Delta l}{\Delta l_1} \frac{l}{A} = \frac{l_1/A_1}{l_2/A_2} = \frac{l_1 A_2}{l_2 A_1}$$

$$\Rightarrow \frac{\Delta l_1}{\Delta l_2} = \frac{l_1/A_1}{r_2^2/r_1^2} = \frac{1}{2} \cdot \left(\frac{1}{2}\right)^2 = \frac{1}{8}$$

---



## Question 119

In the figure, pendulum bob on left side is pulled a side to a height  $h$  from its initial position. After it is released it collides with the right pendulum bob at rest, which is of same mass. After the collision, the two bobs stick together and rise to a height

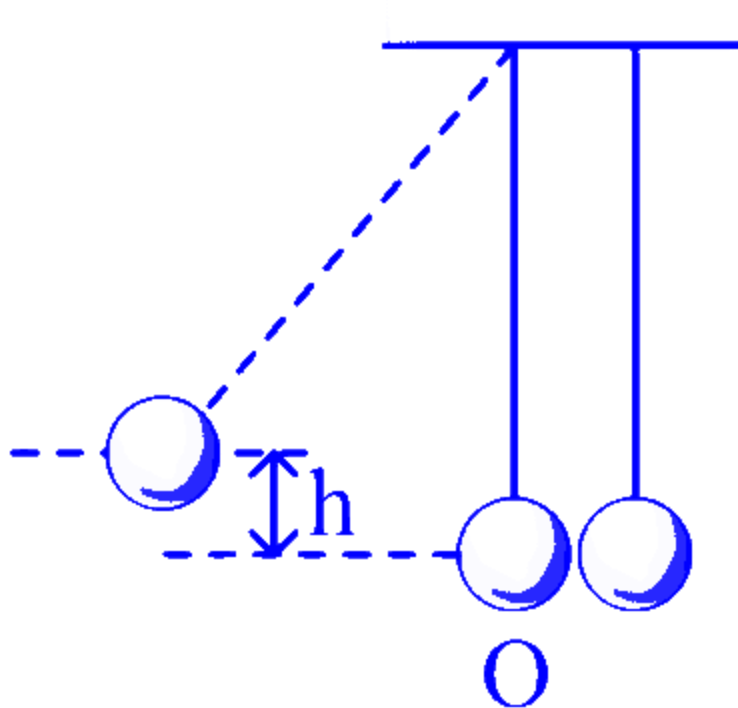

Options:

- A.  $\frac{3h}{4}$
- B.  $\frac{2h}{3}$
- C.  $\frac{h}{2}$
- D.  $\frac{h}{4}$

**Answer: D**

**Solution:**

When bob  $A$  strikes to the bob  $B$ , then

$$mu = (m + m)v'$$

$$\Rightarrow v' = \frac{u}{2} \quad \dots (i)$$

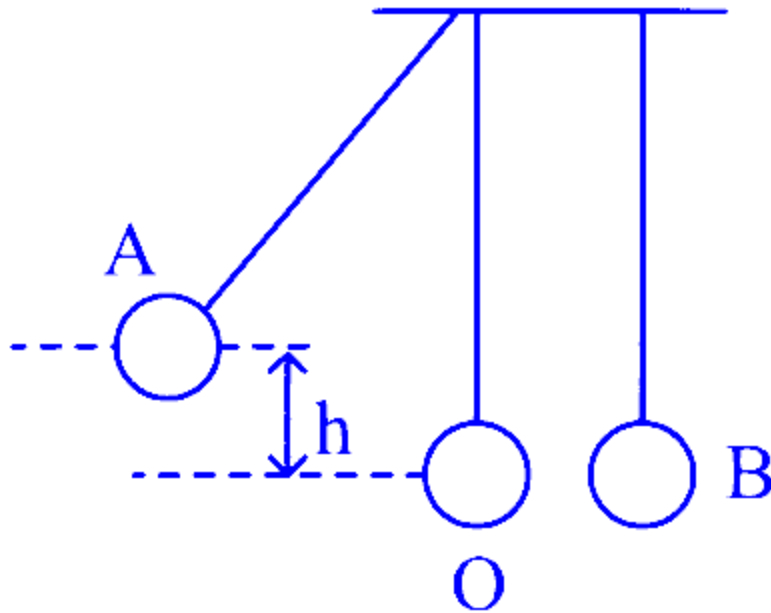

The potential energy of A at height  $h$  gets converted into kinetic energy of this mass, at point O, i.e.

$$mgh = \frac{1}{2}mu^2$$

$$\Rightarrow u = \sqrt{2gh} \quad [\text{From Eq. (i)}]$$

$$\therefore v' = \frac{\sqrt{2gh}}{2} = \sqrt{\frac{gh}{2}}$$

Let the combined mass moves to a height  $h'$ , then total mass =  $2m$

$$\text{Then, } 2mgh' = \frac{1}{2}(2m)v'^2$$

$$\Rightarrow gh' = \frac{gh}{4} \Rightarrow h' = \frac{h}{4}$$

## Question 120

A gas is taken through the cycle  $A \rightarrow B \rightarrow C \rightarrow A$ , as shown in figure. What is the net work done by the gas?

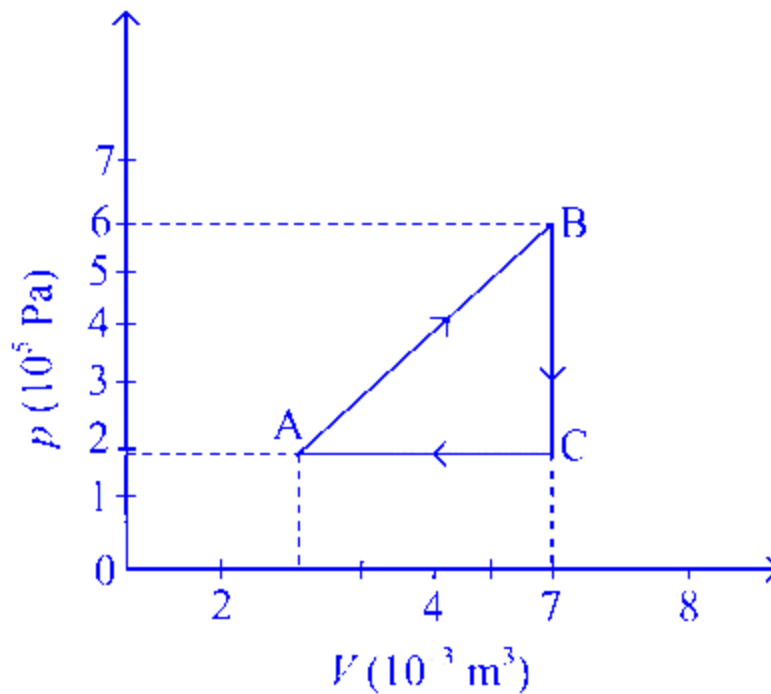

**Options:**

- A. 2000 J
- B. 1000 J
- C. Zero
- D. -2000 J

**Answer: B**

**Solution:**

Net work done by the gas = Area enclosed in  $p$ - $V$  curve, i.e. area of  $\triangle ABC$ .

$$W_{\text{net}} = \frac{1}{2} \times 5 \times 10^{-3} \times 4 \times 10^5 \text{ J} = 10^3 \text{ J} = 1000 \text{ J}$$

---

## Question 121

The gases carbon monoxide (CO) and nitrogen at the same temperature have kinetic energies  $E_1$  and  $E_2$ , respectively. Then,

**Options:**

- A.  $E_1 = E_2$
- B.  $E_1 > E_2$
- C.  $E_1 < E_2$
- D. None of these

**Answer: A**

**Solution:**

The gases carbon monoxide (CO) and nitrogen ( $N_2$ ) are diatomic, so both have equal kinetic energy  $\frac{5}{2}KT$ , i.e.  $E_1 = E_2$

---

## Question 122

**Two wires are made of the same material and have the same volume. The first wire has cross-sectional area  $A$  and the second wire has cross-sectional area  $3A$ . If the length of the first wire is increased by  $\Delta l$  on applying a force  $F$ , how much force is needed to stretch the second wire by the same amount?**

**Options:**

- A.  $4F$
- B.  $6F$
- C.  $9F$
- D.  $F$

**Answer: C**

**Solution:**

According to the question,

For wire 1 : Area of cross-section =  $A_1$ ,

Force applied =  $F_1$

and increase in length =  $\Delta l$ .

From the relation of Young's modulus of elasticity,

$$Y = \frac{Fl}{A\Delta l}$$

Substituting the values for wire 1 in the above relation, we get

$$\Rightarrow Y_1 = \frac{F_1 l_1}{A_1 \Delta l} \quad \dots \text{(i)}$$

For wire 2: Area of cross-section =  $A_2$

Force applied =  $F_2$

increase in length =  $\Delta l$

$$\text{Similarly, } Y_2 = \frac{F_2 l_2}{A_2 \Delta l} \quad \dots \text{(ii)}$$

$$\because \text{Volume, } V = Al \text{ or } l = \frac{V}{A}$$

Substituting the value of  $l$  in Eqs. (i) and (ii), we get

$$Y_1 = \frac{F_1 V}{A_1^2 \Delta l} \text{ and } Y_2 = \frac{F_2 V}{A_2^2 \Delta l}$$

As it is given that the wires are made up of same material,

$$\text{i.e. } Y_1 = Y_2$$

$$\Rightarrow \frac{F_1 V}{A_1^2 \Delta l} = \frac{F_2 V}{A_2^2 \Delta l} \Rightarrow \frac{F_1}{F_2} = \frac{A_1^2}{A_2^2} = \frac{A^2}{9A^2} = \frac{1}{9} \quad (\because A_1 = A \text{ and } A_2 = 3A)$$

$$\text{or } F_2 = 9F_1 = 9F \quad (\text{given, } F_1 = F)$$

---

## Question 123

**Starting from the centre of the earth having radius  $R$ , the variation of  $g$  (acceleration due to gravity) is shown by**

**Options:**

A.

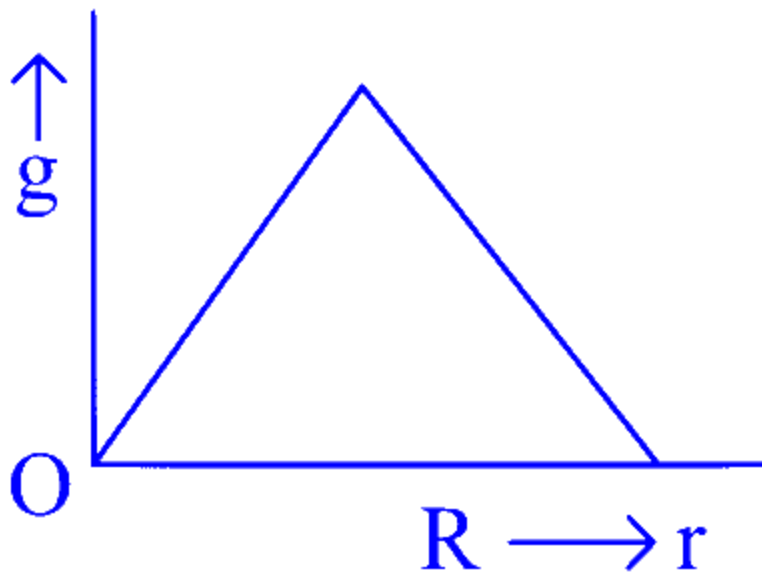

B.

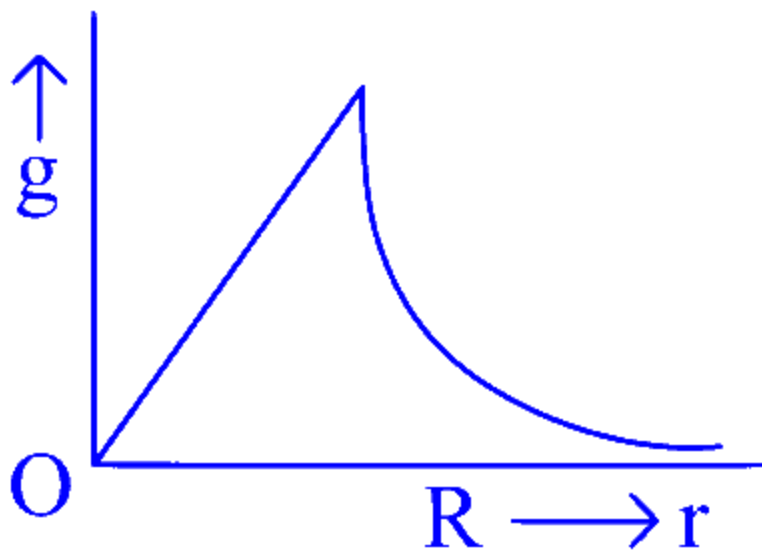

C.

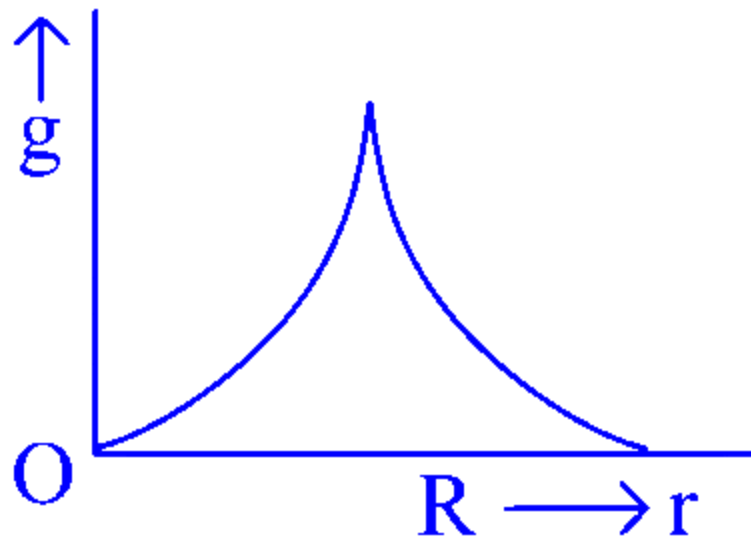

D.

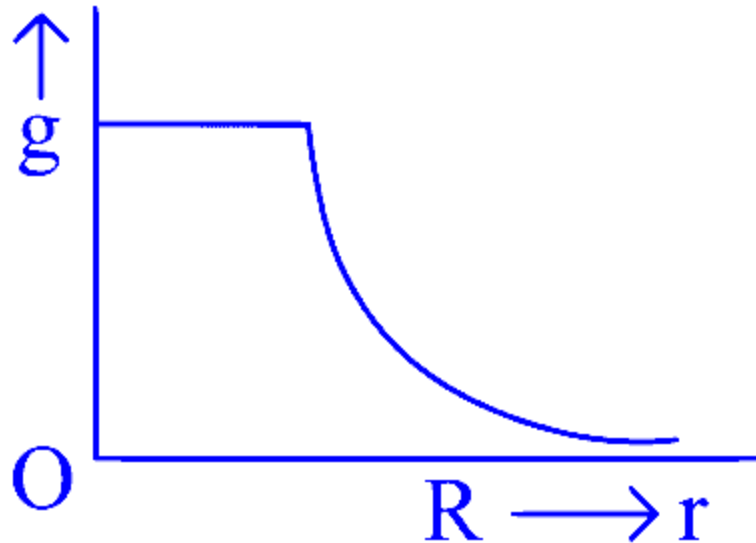

**Answer: B**

**Solution:**

Acceleration due to gravity at a depth  $d$  below the surface of the earth is given by

$$\begin{aligned} g_{\text{depth}} &= g_{\text{surface}} \left( 1 - \frac{d}{R} \right) \\ &= g_{\text{surface}} \left[ \frac{R-d}{R} \right] = g_{\text{surface}} \left( \frac{r}{R} \right) \end{aligned}$$

Also, for a point at height  $h$  above surface,

$$g_{\text{height}} = g_{\text{surface}} \left[ \frac{R^2}{(R+h)^2} \right]$$

Therefore, we can say that value of  $g$  increases from centre to maximum at the surface and then decreases as depicted in graph (b).

---

## Question 124

**A long spring, when stretched by a distance  $x$ , has potential energy  $U$ . On increasing the stretching to  $nx$ , the potential energy of the spring will be**

**Options:**

A.  $\frac{U}{n}$

B.  $nU$

C.  $n^2U$

D.  $\frac{U}{n^2}$

**Answer: C**

**Solution:**

Potential energy of the spring,

$$U = \frac{1}{2}kx^2 \quad \dots (i)$$

and  $U' = \frac{1}{2}k(nx)^2 \Rightarrow U' = n^2 \frac{1}{2}kx^2$

$\Rightarrow U' = n^2U$  [From Eq. (i)]

---

## Question 125

**With what velocity should an observer approach a stationary sound source, so that the apparent frequency of sound should appear double the actual frequency?**

**Options:**

A.  $v/2$

B.  $3v$

C.  $2v$

D.  $v$

**Answer: D**

**Solution:**

By using  $v' = v \left[ \frac{v-v_0}{v-v_s} \right]$

$\Rightarrow 2v = v \left[ \frac{v-v_0}{v-0} \right]$

$\Rightarrow v_0 = -v$



Negative sign indicates that observer is moving opposite to the direction of velocity of sound.

---

## Question 126

A dielectric of dielectric constant  $K$  is introduced such that half of its area of a capacitor of capacitance  $C$  is occupied by it. The new capacity is

Options:

A.  $2C$

B.  $\frac{C}{2}$

C.  $\frac{(1+K)C}{2}$

D.  $2C(1 + K)$

**Answer: C**

**Solution:**

The dielectric is introduced such that half of its area is occupied by it.

In the given case, the two capacitors are in parallel.

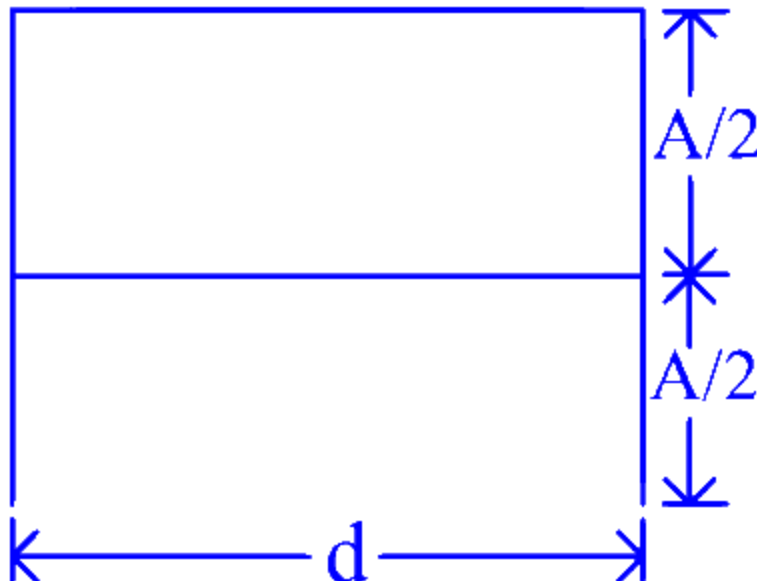

$$\therefore C' = C_1 + C_2$$

But  $C_1 = \frac{A\epsilon_0}{2d}$  and  $C_2 = \frac{KA\epsilon_0}{2d}$

Thus,  $C' = \frac{A\epsilon_0}{2d} + \frac{KA\epsilon_0}{2d} \Rightarrow C' = \frac{C}{2}(1 + K)$

---

## Question 127

Two very long straight parallel wires carry currents  $i$  and  $2i$  in opposite directions. The distance between the wires is  $r$ . At a certain instant of time a point charge  $q$  is at a point equidistant from the two wires in the plane of the wires. Its instantaneous velocity  $v$  is perpendicular to this plane. The magnitude of the force due to the magnetic field acting on the charge at this instant is

Options:

A. zero

B.  $\frac{3\mu_0}{2\pi} \frac{iqv}{r}$

C.  $\frac{\mu_0}{\pi} \frac{iqv}{r}$

D.  $\frac{\mu_0}{2\pi} \frac{iqv}{r}$

**Answer: A**

**Solution:**

The magnetic field induction at  $P$  due to currents through both the wires is

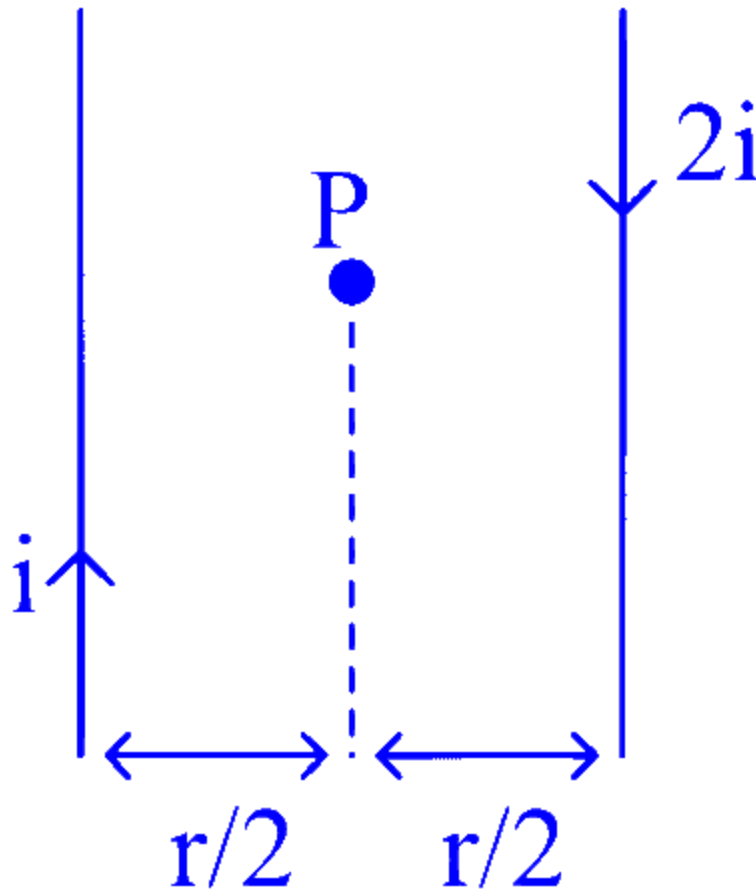

$$B = \frac{\mu_0}{4\pi} \frac{2i}{(r/2)} + \frac{\mu_0}{4\pi} \frac{2(2i)}{(r/2)} = \frac{\mu_0}{4\pi} \cdot \frac{12i}{r}$$

acting perpendicular to plane of wire inwards. Now,  $B$  and  $v$  are acting in the same direction, i.e.  $\theta = 0^\circ$

Force on charged particle is  $F = qvB \sin \theta = qvB \times 0 = 0$ .

---

## Question 128

**The magnetic flux linked with a coil satisfies the relation**

**$\phi = (4t^2 + 6t + 9)$  Wb, where  $t$  is time in second. The emf induced in the coil at  $t = 2$  s is**

**Options:**

A. 22 V

B. 18 V

C. 16 V

D. 40 V

**Answer: A**

**Solution:**

Given,  $\phi = (4t^2 + 6t + 9)$  Wb and  $t = 2$  s

We know that,  $|\varepsilon| = \frac{d\phi}{dt}$

Here,  $\frac{d\phi}{dt} = |8t + 6| \Rightarrow \left(\frac{d\phi}{dt}\right)_{t=2} = 8 \times 2 + 6$

Induced emf in the coil = 22 V

---

## Question 129

**The instantaneous values of alternating current and voltages in a circuit given as**

$$i = \frac{1}{\sqrt{2}} \sin(100\pi t) \text{ amp}$$

$$e = \frac{1}{\sqrt{2}} \sin(100\pi t + \pi/3) \text{ volt}$$

**The average power (in watts) consumed in the circuit is**

**Options:**

A.  $\frac{1}{4}$

B.  $\frac{\sqrt{3}}{4}$

C.  $\frac{1}{2}$

D.  $\frac{1}{8}$

**Answer: D**

## Solution:

Given,

$$i = \frac{1}{\sqrt{2}} \sin(100\pi t) \text{ amp}$$

$$\text{and } e = \frac{1}{\sqrt{2}} \sin(100\pi t + \pi/3) \text{ volt}$$

$$\Rightarrow i_0 = \frac{1}{\sqrt{2}} \text{ and } e_0 = \frac{1}{\sqrt{2}}$$

We know that, average power,

$$\begin{aligned} P_{\text{av}} &= V_{\text{rms}} \times i_{\text{rms}} \cos \phi = \frac{1}{2} \times \frac{1}{2} \times \cos 60^\circ \\ &\left( \because i_{\text{rms}} = i_0/\sqrt{2} \text{ and } V_{\text{rms}} = V_0/\sqrt{2} \right) \\ &= \frac{1}{2} \times \frac{1}{2} \times \frac{1}{2} = \frac{1}{8} \text{ W} \end{aligned}$$

---

## Question 130

**A car is moving towards a high cliff. The car driver sounds a horn of frequency  $f$ . The reflected sound heard by the driver has a frequency  $2f$ . If  $v$  be the velocity of sound, then the velocity of the car in the same velocity units, will be**

**Options:**

A.  $\frac{v}{\sqrt{2}}$

B.  $\frac{v}{3}$

C.  $\frac{v}{4}$

D.  $\frac{v}{2}$

**Answer: B**

## Solution:

When the sound is reflected from the cliff, it approaches the driver of the car. Therefore, the driver, acts as an observer and both the source (car) and observer are moving.

Hence, apparent frequency heard by the observer (driver) is given by

$$f' = f \left( \frac{v+v_o}{v-v_s} \right) \quad \dots (i)$$

where,  $v_s$  = velocity of sound

and  $v_o$  = velocity of the car

Thus, Eq. (i) becomes

$$2f = f \left( \frac{v + v_o}{v - v_o} \right)$$

$$\Rightarrow 2v - 2v_o = v + v_o \Rightarrow 3v_o = v \Rightarrow v_o = \frac{v}{3}$$

---

## Question 131

**If escape velocity on earth surface is  $11.1 \text{ kmh}^{-1}$ , then find the escape velocity on moon surface. If mass of moon is  $\frac{1}{81}$  times of mass of earth and radius of moon is  $\frac{1}{4}$  times radius of earth.**

**Options:**

A.  $2.46 \text{ kmh}^{-1}$

B.  $3.46 \text{ kmh}^{-1}$

C.  $4.4 \text{ kmh}^{-1}$

D. None of these

**Answer: A**

**Solution:**

Given, Escape velocity on the surface of the earth is given by

i.e:

$$v_e = \sqrt{2gR_e}$$

$$v_e = \sqrt{\frac{2GM_e}{R_e}} \quad \dots (i)$$

$$\text{Mass of the moon, } M_m = \frac{M_e}{81}$$

$$\text{Radius of the moon, } R_m = \frac{R_e}{4}$$

∴ Escape velocity on the surface of the moon

$$v_m = \sqrt{\frac{2GM_m}{R_m}} = \sqrt{\frac{2G\left(\frac{M_e}{81}\right)}{\frac{R_e}{4}}} = \frac{2\sqrt{2}}{9} \sqrt{\frac{GM_e}{R_e}}$$

From Eq. (i),

$$= \frac{2}{9} \sqrt{\frac{2GM_e}{R_e}} = \frac{2}{9} v_e$$

$$\text{Escape velocity } v_e = 11.1 \text{ km/h}$$

$$= \frac{2}{9} \times 11.1 = 2.46 \text{ km h}^{-1}$$

---

## Question 132

An ideal gas goes from state  $A$  to state  $B$  via three different processes as indicated in the  $p$ - $V$  diagram. If  $Q_1, Q_2$  and  $Q_3$  indicate the heat absorbed by the three processes and  $\Delta U_1, \Delta U_2$  and  $\Delta U_3$  indicate the change in internal energy along the three processes respectively, then

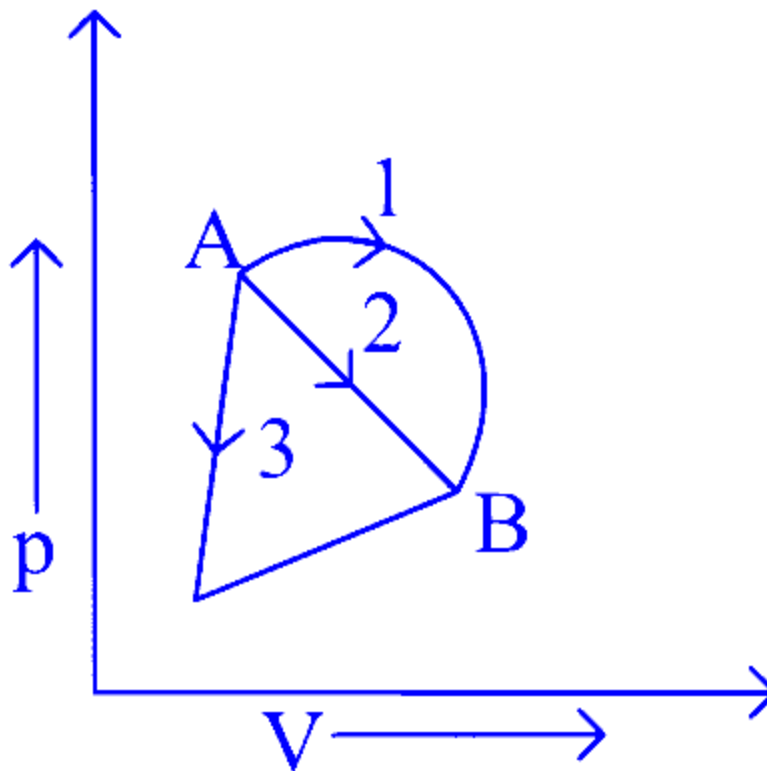

**Options:**

- A.  $Q_1 > Q_2 > Q_3$  and  $\Delta U_1 = \Delta U_2 = \Delta U_3$   
B.  $Q_3 > Q_2 > Q_1$  and  $\Delta U_1 = \Delta U_2 = \Delta U_3$   
C.  $Q_1 = Q_2 = Q_3$  and  $\Delta U_1 > \Delta U_2 > \Delta U_3$   
D.  $Q_3 > Q_2 > Q_1$  and  $\Delta U_1 > \Delta U_2 > \Delta U_3$

**Answer: A**

**Solution:**

For all processes 1, 2 and 3

Change in internal energy, i.e.

$$\Delta U = U_B - U_A$$
$$\therefore \Delta U_1 = \Delta U_2 = \Delta U_3 \Rightarrow Q = \Delta U + \Delta W$$

Now,  $\Delta W =$  work done by the gas, i.e. area under  $p$ - $V$  curve.

As, area (1)  $>$  area(2)  $>$  area (3)

$$\therefore \Delta W_1 > \Delta W_2 > \Delta W_3$$

$$\therefore Q_1 > Q_2 > Q_3$$

---

## Question 133

**In the series L-C-R circuit shown, the impedance is**



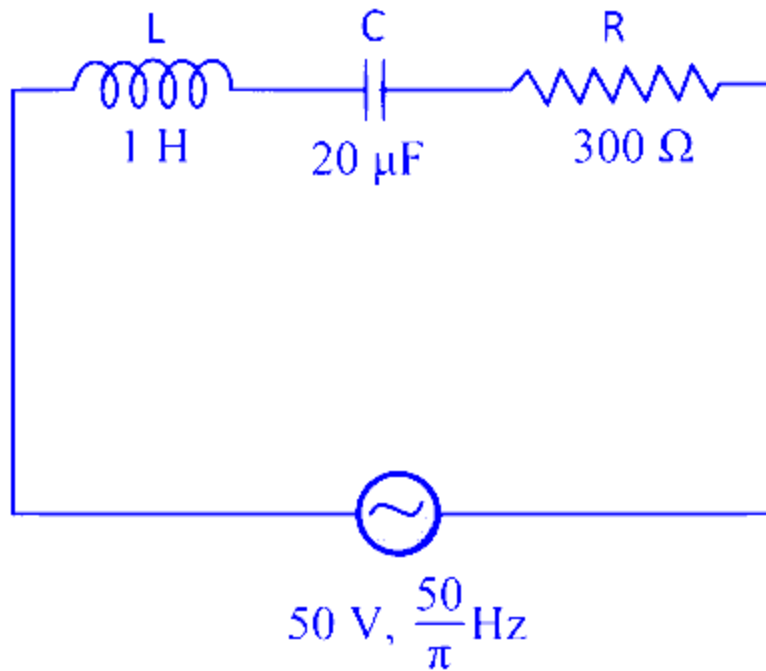

**Options:**

- A.  $200\Omega$
- B.  $100\Omega$
- C.  $300\Omega$
- D.  $500\Omega$

**Answer: D**

**Solution:**

Here,  $L = 1\text{H}$ ,  $C = 20\mu\text{F}$ ,  $R = 300\Omega$

$$X_L = 2\pi fL = 2\pi \left(\frac{50}{\pi}\right) \times 1 = 100\Omega$$

$$X_C = \frac{1}{2\pi fC} = \frac{1}{2\pi \left(\frac{50}{\pi}\right) 20 \times 10^{-6}} = 500\Omega$$

$$\begin{aligned} \text{Impedance, } Z &= \sqrt{R^2 + (X_C - X_L)^2} \\ &= \sqrt{(300)^2 + (400)^2} = 500\Omega \end{aligned}$$

**Question 134**

In Young's double slit interference experiment, using two coherent waves of different amplitudes, the intensities ratio between bright and dark fringes is 3 . Then, the value of the ratio of the amplitudes of the wave that arrive there is

Options:

A.  $\left(\frac{\sqrt{3}+1}{\sqrt{3}-1}\right)$

B.  $\left(\frac{\sqrt{3}-1}{\sqrt{3}+1}\right)$

C.  $\sqrt{3} : 1$

D.  $1 : \sqrt{3}$

Answer: A

Solution:

$$\text{Here, } \frac{I_{\text{bright}}}{I_{\text{dark}}} = \frac{I_{\text{max}}}{I_{\text{min}}} = 3 \quad (\text{given})$$

$$\Rightarrow \frac{(a_1 + a_2)^2}{(a_1 - a_2)^2} = \frac{3}{1} \Rightarrow \frac{a_1 + a_2}{a_1 - a_2} = \sqrt{3}$$

$$\Rightarrow a_1 + a_2 = \sqrt{3}(a_1 - a_2) \Rightarrow \frac{a_1}{a_2} = \left(\frac{\sqrt{3} + 1}{\sqrt{3} - 1}\right)$$

---

## Question 135

The wavelength of the first line of Lyman series for H - atom is equal to that of the second line of Balmer series for a H-like ion. The atomic number Z of H-like ion is

Options:

A. 4

B. 1

C. 2

D. 3

**Answer: C**

**Solution:**

Lyman series of H-atom, we can write

$$\frac{hc}{\lambda} = Rhc \left( \frac{1}{1^2} - \frac{1}{2^2} \right)$$

where, symbols have their usual meaning and for second line of Balmer series of H-like ion

$$\frac{hc}{\lambda} = Z^2 Rhc \left( \frac{1}{2^2} - \frac{1}{4^2} \right)$$

$$\text{Therefore, } \left( \frac{1}{1^2} - \frac{1}{2^2} \right) = Z^2 \left( \frac{1}{4} - \frac{1}{16} \right)$$

$$\left( 1 - \frac{1}{4} \right) = Z^2 \left( \frac{1}{4} - \frac{1}{16} \right)$$

$$\Rightarrow Z = 2.19 \simeq 2$$

The approximately value of  $Z$  will be 2.

---

## Question 136

**If 150 J of heat is added to a system and the work done by the system is 110 J, then change in internal energy will be**

**Options:**

A. 40 J

B. 110 J

C. 150 J

D. 260 J

**Answer: A**

**Solution:**

From the first law of thermodynamics, if an amount of heat  $Q$  is given to a system, a part of it is used in increasing the internal energy  $\Delta U$  of the system and the rest in doing work  $W$  by the system.

$$\therefore Q = \Delta U + W$$

$$\Rightarrow \Delta U = Q - W \Rightarrow \Delta U = 150 - 110$$

$$= 40 \text{ J}$$

---

## Question 137

In the figure below, the capacitance of each capacitor is  $3\mu\text{F}$ . The effective capacitance between  $A$  and  $B$  is

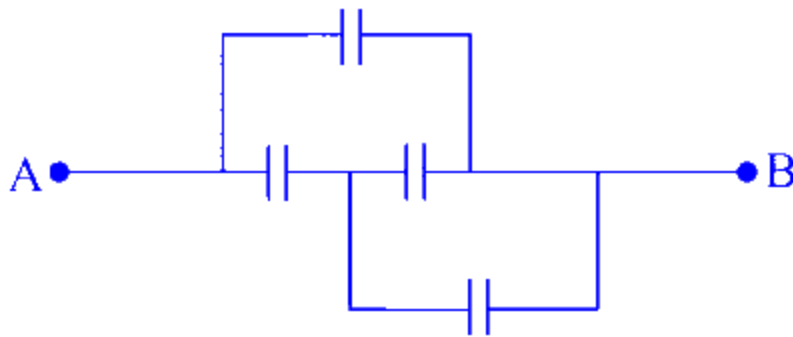

**Options:**

A.  $\frac{3}{4}\mu\text{F}$

B.  $3\mu\text{F}$

C.  $6\mu\text{F}$

D.  $5\mu\text{F}$

**Answer: D**

**Solution:**

From figure,

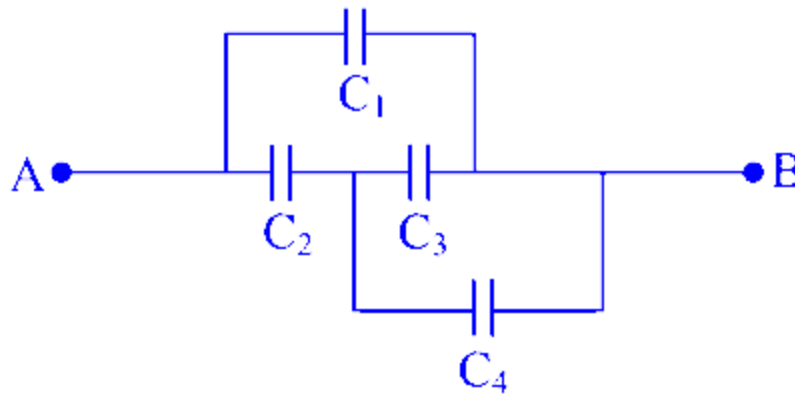

$$C_1 = C_2 = C_3 = C_4 = 3\mu\text{F} \quad (\text{given})$$

$\therefore C_4$  and  $C_3$  are in parallel, i.e.

$$C_{\text{eq}} = C_4 + C_3 = (3 + 3)\mu\text{F} = 6\mu\text{F}$$

Now arrangement of capacitors will be as follows

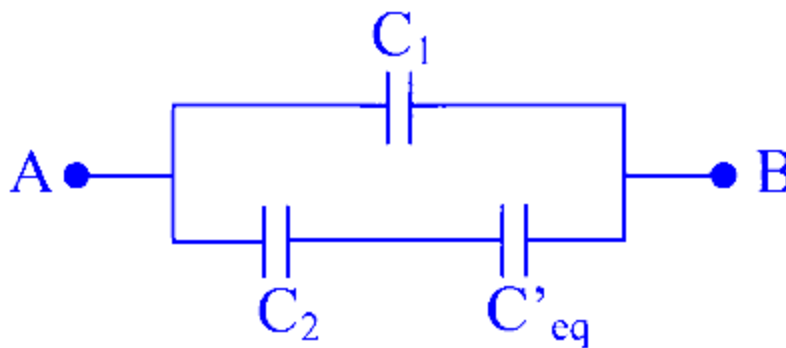

$\therefore C_1$  is in parallel with the series combination of  $C_2$  and  $C'_{\text{eq}}$ .

$\therefore C''_{\text{eq}}$  between A and B

$$= \frac{(C_2 \times C'_{\text{eq}})}{C_2 + C'_{\text{eq}}} + C_1 \Rightarrow \left(\frac{3 \times 6}{3 + 6}\right) + 3 = 5\mu\text{F}$$

## Question 138

The first emission of hydrogen atomic spectrum in Lyman series appears at a wavelength of

Options:

A.  $\frac{3R}{4} \text{ cm}^{-1}$

B.  $\frac{4}{3R} \text{ cm}$

C.  $\frac{7R}{144} \text{ cm}^{-1}$

D.  $\frac{400}{9R} \text{ cm}$

**Answer: B**

**Solution:**

We know that,  $\frac{1}{\lambda} = R \left( \frac{1}{n_1^2} - \frac{1}{n_2^2} \right)$

$\Rightarrow \frac{1}{\lambda} = R \left( \frac{1}{1^2} - \frac{1}{2^2} \right) = \frac{3R}{4} \Rightarrow \lambda = \frac{4}{3R} \text{ cm}$

---

## Question 139

**In Young's double slit experiment, the ratio of maximum and minimum intensities in the fringe system is 9 : 1. The ratio of amplitudes of coherent sources is**

**Options:**

A. 9 : 1

B. 3 : 1

C. 2 : 1

D. 1 : 1

**Answer: C**

**Solution:**

Assume, Young's double slit experiment, amplitudes corresponding to the sources  $S_1$  and  $S_2$  be  $a_1$  and  $a_2$  and intensities be  $I_1$  and  $I_2$  respectively.

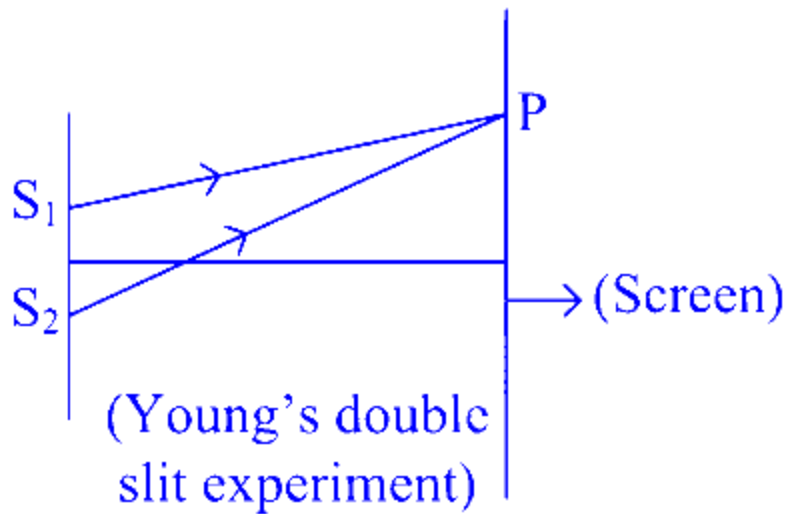

So,  $I_{\max} \propto a_{\max}^2$  and  $I_{\min} \propto a_{\min}^2$

$$\Rightarrow \frac{I_{\max}}{I_{\min}} = \left( \frac{a_{\max}}{a_{\min}} \right)^2 = \left( \frac{a_1 + a_2}{a_1 - a_2} \right)^2$$

According to given question,

$$\frac{I_{\max}}{I_{\min}} = \frac{9}{1}$$

$$\Rightarrow 9 = \left( \frac{a_1/a_2 + 1}{a_1/a_2 - 1} \right)^2$$

$$\Rightarrow (3)^2 = \left( \frac{a_1/a_2 + 1}{a_1/a_2 - 1} \right)^2 \quad (\text{given})$$

$$\Rightarrow 3 = \frac{a_1/a_2 + 1}{a_1/a_2 - 1} \Rightarrow 3 = \frac{\left( \frac{a_1 + a_2}{a_2} \right)}{\left( \frac{a_1 - a_2}{a_2} \right)} \Rightarrow 3 = \frac{a_1 + a_2}{a_1 - a_2}$$

$$\Rightarrow 3(a_1 - a_2) = a_1 + a_2 \Rightarrow 3a_1 - 3a_2 = a_1 + a_2$$

$$\Rightarrow 2a_1 = 4a_2 \Rightarrow \frac{a_1}{a_2} = \frac{4}{2} \Rightarrow a_1 : a_2 = 2 : 1$$

## Question 140

**In the case of an inductor**

**Options:**

A. voltage lags the current by  $\pi/2$

B. voltage leads the current by  $\pi/2$

C. voltage leads the current by  $\pi/3$

D. voltage leads the current by  $\pi/4$

**Answer: B**

**Solution:**

In case of an inductor, voltage leads the current by phase difference of  $\frac{\pi}{2}$ .

---

## Question 141

**The height vertically above the earth's surface at which the acceleration due to gravity becomes 1% of its value at the surface is**

**Options:**

A. 8R

B. 9R

C. 10R

D. 20R

**Answer: B**

**Solution:**

Acceleration due to gravity at a height  $h$  from the earth's surface,

$$g' = \frac{GM}{(R+h)^2}$$

Given,  $g' = 1\% \text{ of } g = \frac{g}{100}$

$$\Rightarrow \frac{g}{100} = \frac{GM}{(R+h)^2}$$

$$\frac{(R+h)^2}{100} = \frac{GM}{g} \text{ or } \frac{(R+h)^2}{100} = R^2 \quad \left( \because g = \frac{GM}{R^2} \right)$$

or  $R+h = 10R$

$$h = 9R$$



where,  $R$  is the radius of the earth.

---

## Question 142

If  $C$  be the capacitance and  $V$  be the electric potential, then the dimensional formula of  $CV^2$  is

Options:

A.  $[ML^2 T^{-2} A^0]$

B.  $[MLT^{-2} A^{-1}]$

C.  $[M^0LT^{-2} A^0]$

D.  $[ML^{-3}TA]$

**Answer: A**

**Solution:**

We know that energy,  $E = \frac{1}{2}CV^2$

Dimensions of  $CV^2 =$  Dimensions of energy,  $E = [ML^2 T^{-2} A^0]$

---

## Question 143

Which logic gate is represented by the following combination logic gates?

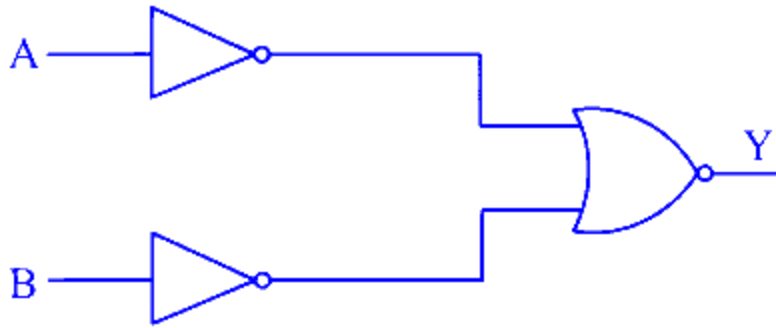

**Options:**

- A. OR
- B. NAND
- C. AND
- D. NOR

**Answer: C**

**Solution:**

The output,

$$Y = \overline{\overline{A} + \overline{B}} = \overline{\overline{A}} \cdot \overline{\overline{B}} = A \cdot B$$

This is the boolean expression for AND gate.

---

## Question 144

**An LED is constructed from a  $p$ - $n$  junction diode using GaAsP. The energy gap is 1.9 eV. The wavelength of the light emitted will be equal to**

**Options:**

- A.  $10.4 \times 10^{-26}$  m
- B. 654 nm
- C.  $654 \overset{\circ}{\text{A}}$

D.  $654 \times 10^{-11} \text{ m}$

**Answer: B**

**Solution:**

The energy of light of wavelength  $\lambda$  is given by

$$E = hv = \frac{hc}{\lambda}$$
$$\Rightarrow \lambda = \frac{hc}{E} \quad \dots (i)$$

Here,  $h$  = Planck's constant =  $6.63 \times 10^{-34} \text{ J - s}$

$c$  = speed of light =  $3 \times 10^8 \text{ m/s}$

$E$  = energy gap =  $1.9 \text{ eV}$

$$= 1.9 \times 1.6 \times 10^{-19} \text{ J}$$

Substituting the given values in Eq. (i), we get

$$\Rightarrow \lambda = \frac{6.63 \times 10^{-34} \times 3 \times 10^8}{1.9 \times 1.6 \times 10^{-19}} = 6.54 \times 10^{-7} \text{ m}$$
$$\approx 654 \text{ nm}$$

Thus, the wavelength of light emitted from LED will be 654 nm.

---

## Question 145

**A body is projected vertically upwards. The times corresponding to height  $h$  while ascending and while descending are  $t_1$  and  $t_2$ , respectively. Then, the velocity of projection will be (take,  $g$  as acceleration due to gravity)**

**Options:**

A.  $\frac{g\sqrt{t_1 t_2}}{2}$

B.  $\frac{g(t_1+t_2)}{2}$

C.  $g\sqrt{t_1 t_2}$

D.  $g \frac{t_1 t_2}{(t_1+t_2)}$

**Answer: B**

## **Solution:**

Let  $v$  be initial velocity of vertical projection and  $t$  be the time taken by the body to reach a height  $h$  from ground.

Here,  $u = u, a = -g, s = h, t = t$

Using,  $s = ut + \frac{1}{2}at^2$ , we have

$$\text{or } h = ut + \frac{1}{2}(-g)t^2$$

$$gt^2 - 2ut + 2h = 0$$

$$\therefore t = \frac{2u \pm \sqrt{4u^2 - 4g \times 2h}}{2g} = \frac{u \pm \sqrt{u^2 - 2gh}}{g}$$

It means  $t$  has two values, i.e.

$$t_1 = \frac{u + \sqrt{u^2 - 2gh}}{g} \Rightarrow t_2 = \frac{u - \sqrt{u^2 - 2gh}}{g}$$

$$t_1 + t_2 = \frac{2u}{g} \text{ or } u = \frac{g(t_1 + t_2)}{2}$$

---

## **Question 146**

**When a certain metal surface is illuminated with light of frequency  $\nu$ , the stopping potential for photoelectric current is  $V_0$ . When the same surface is illuminated by light of frequency  $\frac{\nu}{2}$ , the stopping potential is  $\frac{V_0}{4}$ . The threshold frequency for photoelectric emission is**

**Options:**

A.  $\frac{\nu}{6}$

B.  $\frac{\nu}{3}$

C.  $\frac{2\nu}{3}$

D.  $\frac{4\nu}{3}$

**Answer: B**

## Solution:

We know that,

$eV_0 = h\nu - \phi_0$  where,  $V_0 =$  stopping potential

and  $\nu =$  frequency of light.

Case I  $eV_0 = h\nu - \phi_0 \dots$  (i)

Case II  $\frac{eV_0}{4} = \frac{h\nu}{2} - \phi_0$

$\Rightarrow eV_0 = 2h\nu - 4\phi_0 \dots$  (ii)

From Eqs. (i) and (ii), we get

$$h\nu - \phi_0 = 2h\nu - 4\phi_0$$

$$\Rightarrow h\nu = 3\phi_0 \Rightarrow h\nu = 3h\nu_0 \quad (\because \phi_0 = h\nu_0)$$

$$\Rightarrow \nu_0 = \frac{h\nu}{3h} \Rightarrow \nu_0 = \frac{\nu}{3}$$

---

## Question 147

**A fish in water (refractive index  $n$ ) looks at a bird vertically above in the air. If  $y$  is the height of the bird and  $x$  is the depth of the fish from the surface, then the distance of the bird as estimated by the fish is**

**Options:**

A.  $x + y \left(1 - \frac{1}{n}\right)$

B.  $x + ny$

C.  $x + y \left(1 + \frac{1}{n}\right)$

D.  $y + x \left(1 - \frac{1}{n}\right)$

**Answer: B**

## Solution:

When object is in rarer medium and observer is in denser medium, then normal shift,

$$d = (n - 1)h$$

where,  $h$  = real depth =  $y$

Now, apparent depth or the apparent height of the bird from the surface of the water =  $y + (n - 1)y = n \cdot y$ . The total distance of the bird as estimated by fish is  $x + ny$ .

---

## Question 148

**A car starts from rest and accelerates uniformly to a speed of  $180 \text{ kmh}^{-1}$  in 10 s. The distance covered by the car in this time interval is**

**Options:**

A. 500 m

B. 250 m

C. 100 m

D. 200 m

**Answer: B**

**Solution:**

Speed of car,  $v = 180 \text{ kmh}^{-1} = 50 \text{ ms}^{-1}$  and time,  $t = 10 \text{ s}$

$\therefore$  Acceleration of the car,

$$a = \frac{v-u}{t} = \frac{50-0}{10} = 5 \text{ ms}^{-2}$$

Thus, the distance covered by the car,

$$s = \frac{1}{2}at^2 = \frac{1}{2} \times 5 \times (10)^2 = 250 \text{ m}$$

---

## Question 149

**A plane electromagnetic wave of frequency 20 MHz travels through a space along  $x$ -direction. If the electric field vector at a certain point in**

space is  $6 \text{ Vm}^{-1}$ , then what is the magnetic field vector at that point?

**Options:**

A.  $2 \times 10^{-8} \text{ T}$

B.  $\frac{1}{2} \times 10^{-8} \text{ T}$

C.  $2 \text{ T}$

D.  $\frac{1}{2} \text{ T}$

**Answer: A**

**Solution:**

Magnetic field,

$$B = \frac{E}{c}, \text{ where } c = 3 \times 10^8 \text{ m/s.}$$

$$B = \frac{6}{3 \times 10^8} = 2 \times 10^{-8} \text{ T}$$

---

## Question 150

The sides of a parallelogram are represented by vectors

$\vec{p} = 5\hat{i} - 4\hat{j} + 3\hat{k}$  and  $\vec{q} = 3\hat{i} + 2\hat{j} - \hat{k}$ . Then, the area of the parallelogram is

**Options:**

A.  $\sqrt{684}$  sq units

B.  $\sqrt{72}$  sq units

C. 171 sq units

D. 72 sq units

**Answer: A**

## Solution:

Area of a parallelogram =  $|\vec{a} \times \vec{b}|$  where, a and b are sides of parallelogram.

$$\text{Given, } \vec{a} = \vec{p} = 5\hat{i} - 4\hat{j} + 3\hat{k}$$

$$\text{and } \vec{b} = \vec{q} = 3\hat{i} + 2\hat{j} - \hat{k}$$

$$\therefore \vec{a} \times \vec{b} = \begin{vmatrix} \hat{i} & \hat{j} & \hat{k} \\ 5 & -4 & 3 \\ 3 & 2 & -1 \end{vmatrix}$$

$$\Rightarrow \vec{a} \times \vec{b} = \hat{i}(4 - 6) - \hat{j}(-5 - 9) + \hat{k}(10 + 12)$$

$$\Rightarrow \vec{a} \times \vec{b} = -2\hat{i} + 14\hat{j} + 22\hat{k}$$

$$\text{Thus, } |\vec{a} \times \vec{b}| = \sqrt{(2)^2 + (14)^2 + (22)^2} = \sqrt{684} \text{ sq units}$$

---

## Question 151

**If  $\theta_1$  and  $\theta_2$  be the apparent angles of dip observed in two vertical planes at right angles to each other, then the true angle of dip  $\theta$  is given by**

**Options:**

A.  $\cot^2 \theta = \cot^2 \theta_1 + \cot^2 \theta_2$

B.  $\tan^2 \theta = \tan^2 \theta_1 + \tan^2 \theta_2$

C.  $\cot^2 \theta = \cot^2 \theta_1 - \cot^2 \theta_2$

D.  $\tan^2 \theta = \tan^2 \theta_1 - \tan^2 \theta_2$

**Answer: A**

## Solution:

Let the  $B_H$  and  $B_V$  be the horizontal and vertical component of the earth's magnetic field B.

$$\tan \theta = \frac{B_V}{B_H} \Rightarrow \cot \theta = \frac{B_H}{B_V} \dots (i)$$



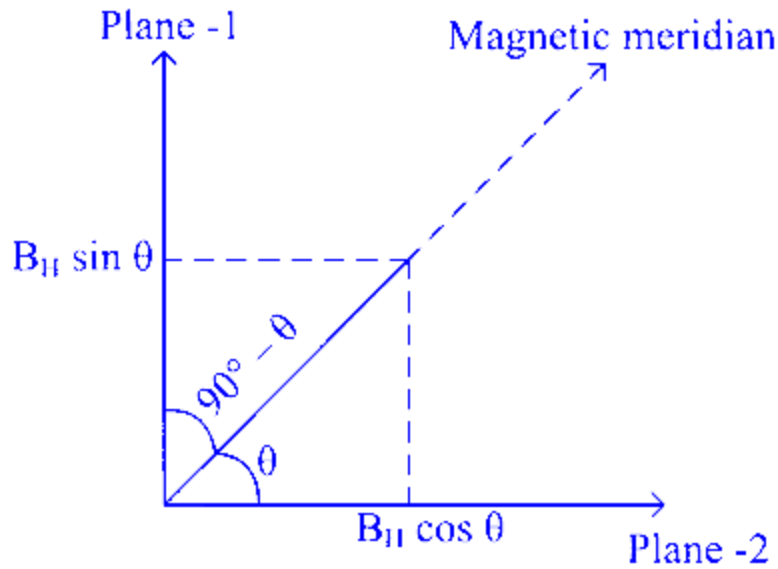

Let plane - 1 and 2 be mutually perpendicular planes making angle  $\theta$  and  $(90^\circ - \theta)$  with magnetic meridian. The vertical component of the earth's magnetic field remains the same in two planes but effective horizontal components in the two planes are given by

$$B_1 = B_H \cos \theta \quad \dots \text{(ii)}$$

$$\text{and } B_2 = B_H \sin \theta \quad \dots \text{(iii)}$$

$$\text{Then, } \tan \theta_1 = \frac{B_V}{B_1} = \frac{B_V}{B_H \cos \theta}$$

$$\cot \theta_1 = \frac{B_H \cos \theta}{B_V} \quad \dots \text{(iv)}$$

$$\text{Similarly, } \Rightarrow \tan \theta_2 = \frac{B_V}{B_2} = \frac{B_V}{B_H \sin \theta}$$

$$\Rightarrow \cot \theta_2 = \frac{B_H \sin \theta}{B_V} \quad \dots \text{(v)}$$

From Eqs. (iv) and (v), we get

$$\begin{aligned} &\Rightarrow \cot^2 \theta_1 + \cot^2 \theta_2 \\ &= \frac{B_H^2 \cos^2 \theta}{B_V^2} + \frac{B_H^2 \sin^2 \theta}{B_V^2} \end{aligned}$$

$$\Rightarrow \cot^2 \theta_1 + \cot^2 \theta_2 = \frac{B_H^2}{B_V^2} (\cos^2 \theta + \sin^2 \theta)$$

$$\Rightarrow \cot^2 \theta_1 + \cot^2 \theta_2 = \cot^2 \theta$$

## Question 152

Let  $K_1$  be the maximum kinetic energy of photoelectrons emitted by light of wavelength  $\lambda_1$  and  $K_2$  corresponding to wavelength  $\lambda_2$ . If

$\lambda_1 = 2\lambda_2$ , then

**Options:**

A.  $2K_1 = K_2$

B.  $K_1 = 2K_2$

C.  $K_1 < K_2/2$

D.  $K_1 > 2K_2$

**Answer: C**

**Solution:**

Here,  $K_1 = \frac{hc}{\lambda_1} - W$  .... (i)

and  $K_2 = \frac{hc}{\lambda_2} - W$  .... (ii)

Substituting  $\lambda_1 = 2\lambda_2$  in Eq. (i), we get

$$K_1 = \frac{hc}{2\lambda_2} - W$$

$$\Rightarrow K_1 = \frac{1}{2} \left( \frac{hc}{\lambda_2} \right) - W = \frac{1}{2}(K_2 + W) - W$$

$$K_1 = \frac{K_2}{2} - \frac{W}{2}$$

$$\Rightarrow K_1 < \frac{K_2}{2}$$

---

## Question 153

**A ball is projected horizontally with a velocity of  $5 \text{ ms}^{-1}$  from the top of a building 19.6 m high. How long will the ball take to hit the ground?**

**Options:**

A.  $\sqrt{2} \text{ s}$

B. 2 s

C.  $\sqrt{3}$  s

D. 3 s

**Answer: B**

**Solution:**

The time taken to hit the ground is given by

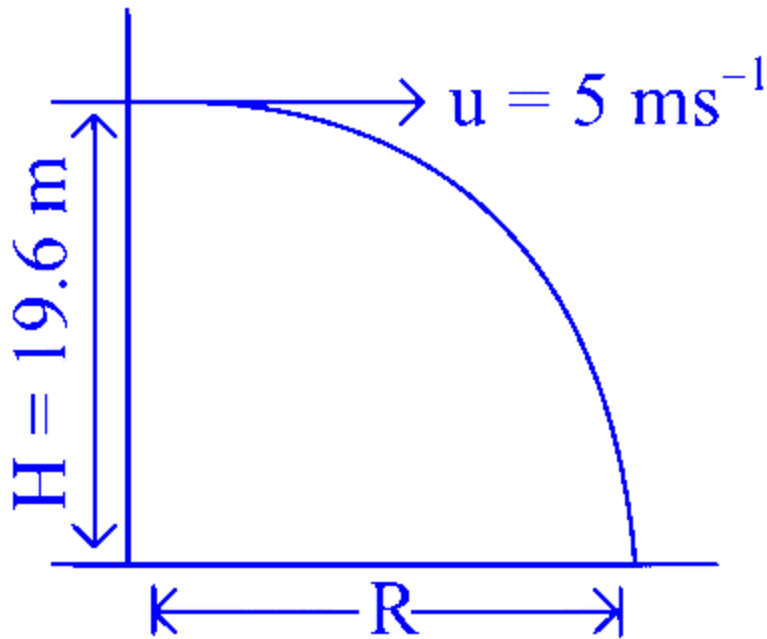

$$T = \sqrt{\frac{2H}{g}} = \sqrt{\frac{2 \times 19.6}{9.8}} = 2 \text{ s}$$

---

## Question 154

**A galvanometer having a resistance of  $8\Omega$  is shunted by a wire of resistance  $2\Omega$ . If the total current is 1 A, the part of it passing through the shunt will be**

**Options:**

A. 0.25 A

B. 0.8 A

C. 0.2 A

D. 0.5 A

**Answer: B**

**Solution:**

Let total current through the parallel combination be  $I$ , the current through the galvanometer be  $I_g$  and the current through the shunt be  $I - I_g$ .

The shunted galvanometer is shown in the figure.

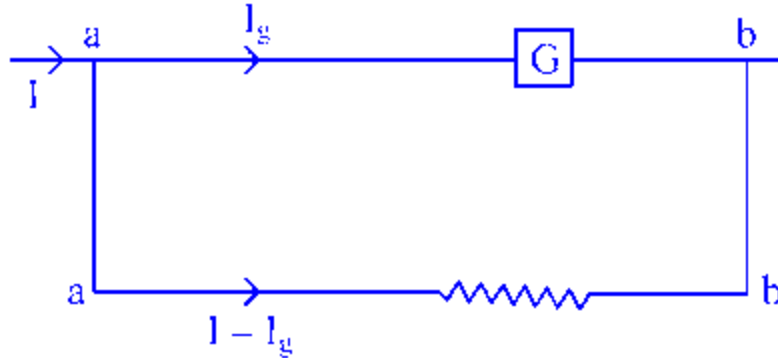

The potential difference,  $V_{ab} = (V_a - V_b)$  is the same for both paths, so  $I_g G = (I - I_g) S$

$$\Rightarrow I_g(G + S) = IS \Rightarrow \frac{I_g}{I} = \frac{S}{S+G}$$

The fraction of current passing through shunt

$$\begin{aligned} &= \frac{I - I_g}{I} = 1 - \frac{I_g}{I} = 1 - \frac{S}{S+G} = \frac{G}{S+G} \\ &= \frac{8}{2+8} = \frac{8}{10} = 0.8 \text{ A} \end{aligned}$$

---

## Question 155

In the diagram shown below,  $m_1$  and  $m_2$  are the masses of two particles and  $x_1$  and  $x_2$  are their respective distances from the origin  $O$ .

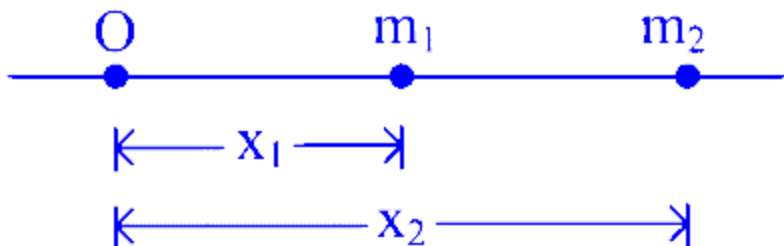

**The centre of mass of the system is**

**Options:**

A.  $\frac{m_1x_2+m_2x_2}{m_1+m_2}$

B.  $\frac{m_1+m_2}{2}$

C.  $\frac{m_1x_1+m_2x_2}{m_1+m_2}$

D.  $\frac{m_1m_2+x_1x_2}{m_1+m_2}$

**Answer: C**

**Solution:**

The centre of mass of the system is given by

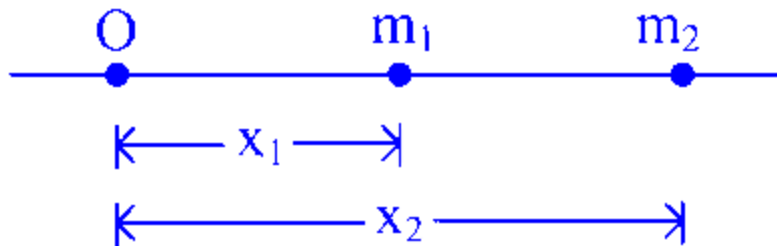

$$x = \frac{m_1x_1+m_2x_2}{m_1+m_2}$$

---

## Question 156

**A block of wood floats in water with  $(4/5)$  th of its volume submerged. If the same block just floats in a liquid, the density of the liquid is (in  $\text{kgm}^{-3}$ )**

**Options:**

A. 1250

B. 600

C. 400

D. 800

**Answer: D**

**Solution:**

Applying Archimedes' principle, submerged part = replaced water

$$\Rightarrow \frac{4}{5}h\rho_w g = h \times \rho_l \times g$$

where,  $\rho_w$  = density of water and  $\rho_l$  = density of the liquid.

$$\therefore \rho_l = \frac{4}{5} \times \rho_w = \frac{4}{5} \times 1000$$

$$\Rightarrow \rho_l = 800 \text{ kgm}^{-3}$$

---

## Question 157

**A balloon with mass  $m$  is descending down with an acceleration  $a$  (where,  $a < g$ ). How much mass should be removed from it so that it starts moving up with an acceleration  $a$  ?**

**Options:**

A.  $\frac{2ma}{g+a}$

B.  $\frac{2ma}{g-a}$

C.  $\frac{ma}{g+a}$

D.  $\frac{ma}{g-a}$

**Answer: A**

**Solution:**

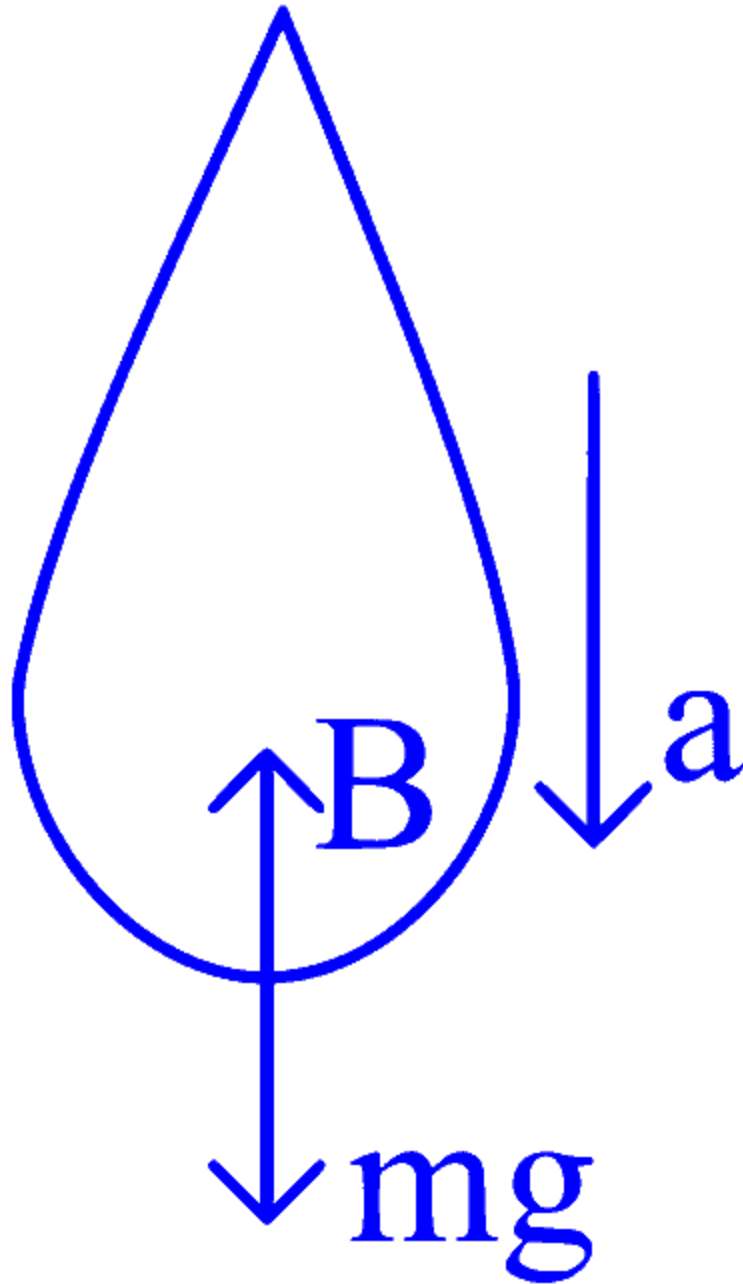

When the balloon is descending down with an acceleration  $a$ ,

$$mg - B = ma \quad \dots (i)$$

where,  $B$  = buoyant force.

Here, we should assume that while removing some mass the volume of balloon and hence buoyant force will not change.

Let the new mass of the balloon is  $m'$ , so

$$B - m'g = m'a \quad \dots (ii)$$

On solving Eqs. (i) and (ii), we get

$$mg - m'g = ma + m'a$$
$$\Rightarrow m(g - a) = m'(g + a) \Rightarrow m' = \frac{m(g - a)}{g + a}$$

So, mass removed,  $\Delta m = m - m'$

$$= m \left[ 1 - \frac{(g-a)}{(g+a)} \right] = m \left[ \frac{g+a-g+a}{g+a} \right] = \frac{2ma}{g+a}$$

---

## Question 158

**A straight wire of length 2 m carries a current of 10 A. If this wire is placed in uniform magnetic field of 0.15 T making an angle of  $45^\circ$  with the magnetic field, the applied force on the wire will be**

**Options:**

- A. 1.5 N
- B. 3 N
- C.  $3\sqrt{2}$  N
- D.  $3/\sqrt{2}$  N

**Answer: D**

**Solution:**

Given,

$$i = 10 \text{ A}, B = 0.15 \text{ T}$$

$$\theta = 45^\circ \text{ and } l = 2 \text{ m}$$

$$\text{Here, } F = ilB \sin \theta = 10 \times 2 \times 0.15 \sin 45^\circ = \frac{3}{\sqrt{2}} \text{ N}$$

---

## Question 159

**Two slabs are of the thicknesses  $d_1$  and  $d_2$ . Their thermal conductivities are  $K_1$  and  $K_2$ , respectively. They are in series. The free**



ends of the combination of these two slabs are kept at temperatures  $\theta_1$  and  $\theta_2$ . Assume  $\theta_1 > \theta_2$ . The temperature  $\theta$  of their common junction is

Options:

- A.  $\frac{K_1\theta_1 + K_2\theta_2}{\theta_1 + \theta_2}$
- B.  $\frac{K_1\theta_1 d_1 + K_2\theta_2 d_2}{K_1 d_2 + K_2 d_1}$
- C.  $\frac{K_1\theta_1 d_2 + K_2\theta_2 d_1}{K_1 d_2 + K_2 d_1}$
- D.  $\frac{K_1\theta_1 + K_2\theta_2}{K_1 + K_2}$

Answer: C

Solution:

For first slab,

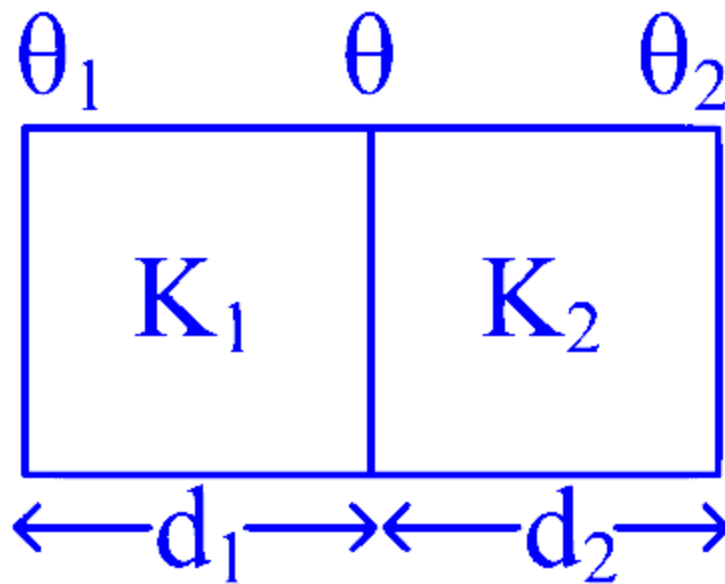

$$\text{Heat current, } H_1 = \frac{K_1(\theta_1 - \theta)A}{d_1}$$

For second slab,

$$\text{Heat current, } H_2 = \frac{K_2(\theta - \theta_2)A}{d_2}$$

As slabs are in series,  $H_1 = H_2$

$$\therefore \frac{K_1(\theta_1 - \theta)A}{d_1} = \frac{K_2(\theta - \theta_2)A}{d_2}$$

$$\Rightarrow \theta = \frac{K_1\theta_1 d_2 + K_2\theta_2 d_1}{K_2 d_1 + K_1 d_2}$$

---

## Question 160

A square wire of each side  $l$  carries a current  $I$ . The magnetic field at the mid-point of the square

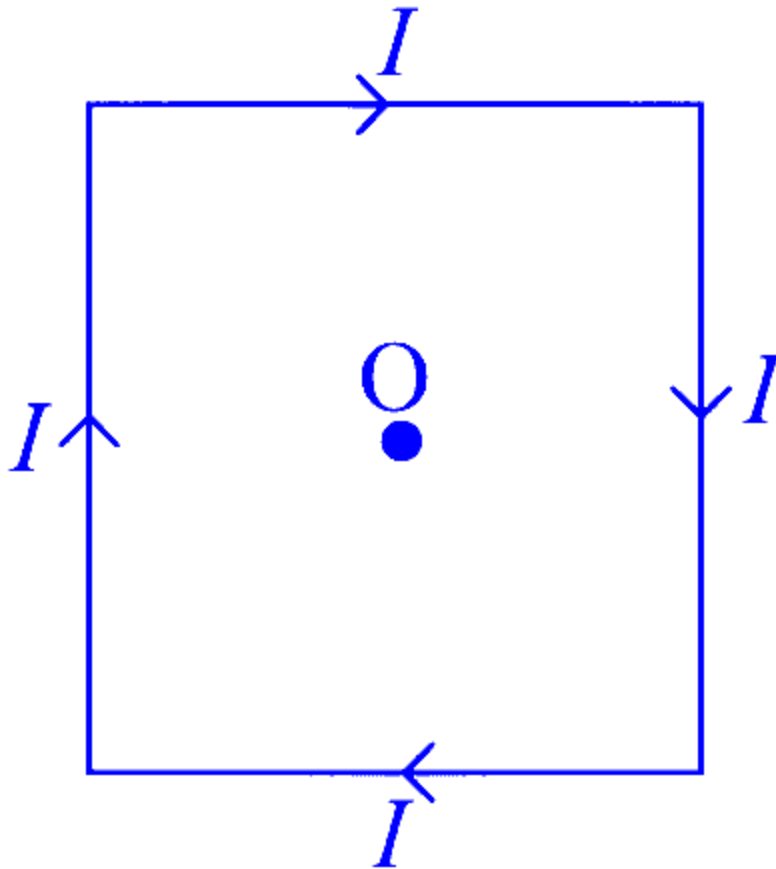

Options:

- A.  $4\sqrt{2} \frac{\mu_0}{4\pi} \frac{I}{l}$
- B.  $8\sqrt{2} \frac{\mu_0}{4\pi} \frac{I}{l}$
- C.  $16\sqrt{2} \frac{\mu_0}{4\pi} \frac{I}{l}$
- D.  $32\sqrt{2} \frac{\mu_0}{4\pi} \frac{I}{l}$

**Answer: B**

**Solution:**

$$B = 4 \left[ \frac{\mu_0}{4\pi} \cdot \frac{I}{a} (\sin \phi_1 + \sin \phi_2) \right]$$

Here,  $a = \frac{l}{2}$  and  $\phi_1 = \phi_2 = 45^\circ$

$$B = 4 \times \frac{\mu_0}{4\pi} \frac{I}{(l/2)} \left[ \frac{1}{\sqrt{2}} + \frac{1}{\sqrt{2}} \right]$$
$$\therefore B = \frac{16}{\sqrt{2}} \left[ \frac{\mu_0 I}{4\pi l} \right] = 8\sqrt{2} \left( \frac{\mu_0}{4\pi} \cdot \frac{I}{l} \right)$$

---

## Question 161

**A cylinder of radius  $r$  and of thermal conductivity  $K_1$  is surrounded by a cylindrical shell of inner radius  $r$  and outer radius  $2r$  made of a material of thermal conductivity  $K_2$ . The effective thermal conductivity of the system is**

**Options:**

A.  $\frac{1}{3}(K_1 + 2K_2)$

B.  $\frac{1}{2}(2K_1 + 3K_2)$

C.  $\frac{1}{3}(3K_2 + 2K_1)$

D.  $\frac{1}{4}(K_1 + 3K_2)$

**Answer: D**

**Solution:**

Both the cylinders are in parallel, for the heat flow from one end as shown

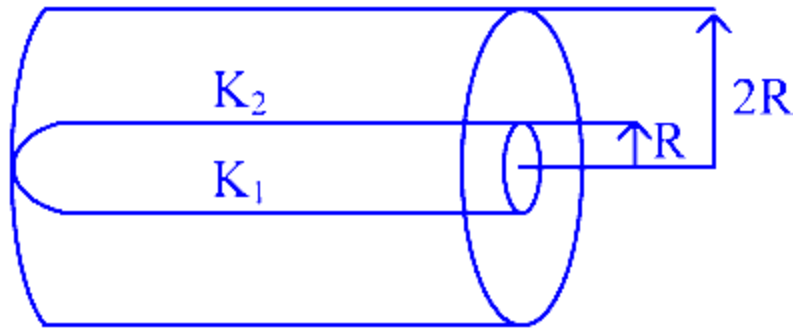

$$\text{So, } K_{\text{eq}} = \frac{K_1 A_1 + K_2 A_2}{A_1 + A_2}$$

where,  $A_1 =$  area of cross-section of inner cylinder  $= \pi R^2$

and  $A_2 =$  area of cross-section of cylindrical shell

$$= \pi \{ (2R)^2 - (R)^2 \} = 3\pi R^2$$

$$\Rightarrow K_{\text{eq}} = \frac{K_1 (\pi R^2) + K_2 (3\pi R^2)}{\pi R^2 + 3\pi R^2} = \frac{1}{4} (K_1 + 3K_2)$$

## Question 162

The speeds of air-flow on the upper and lower surfaces of a wing of an aeroplane are  $v_1$  and  $v_2$ , respectively. If  $A$  is the cross-sectional area of the wing and  $\rho$  is the density of air, then the upward lift is

Options:

A.  $\frac{1}{2} \rho A (v_1 - v_2)$

B.  $\frac{1}{2} \rho A (v_1 + v_2)$

C.  $\frac{1}{2} \rho A (v_1^2 - v_2^2)$

D.  $\frac{1}{2} \rho A (v_1^2 + v_2^2)$

**Answer: C**

**Solution:**

Due to the specific shape of wings, when the aeroplane runs, air passes at higher speed over it as compared to its lower surface. This difference of air speeds above and below the wings, in accordance with Bernoulli's principle, creates a pressure difference, due to which an upward force called 'dynamic lift' acts on the plate.

$\therefore$  Upward lift = pressure difference  $\times$  area of the wings [ $\because F = p \times A$ ]

From Bernoulli's equation,

$$p_1 + \frac{1}{2}\rho v_1^2 = p_2 + \frac{1}{2}\rho v_2^2$$

$$\therefore p_2 - p_1 = \frac{1}{2}\rho (v_1^2 - v_2^2)$$

$$\text{Hence, upward lift} = \frac{1}{2}\rho A (v_1^2 - v_2^2)$$

---

## Question 163

**Two cells with the same emf  $E$  and different internal resistances  $r_1$  and  $r_2$  are connected in series to an external resistance  $R$ . If the potential difference across the first cell is zero then value of  $R$ .**

**Options:**

A.  $\sqrt{r_1 r_2}$

B.  $r_1 + r_2$

C.  $r_1 - r_2$

D.  $\frac{r_1 + r_2}{2}$

**Answer: C**

**Solution:**

Here are two batteries with emf  $E$  each and the internal resistances  $r_1$  and  $r_2$ , respectively

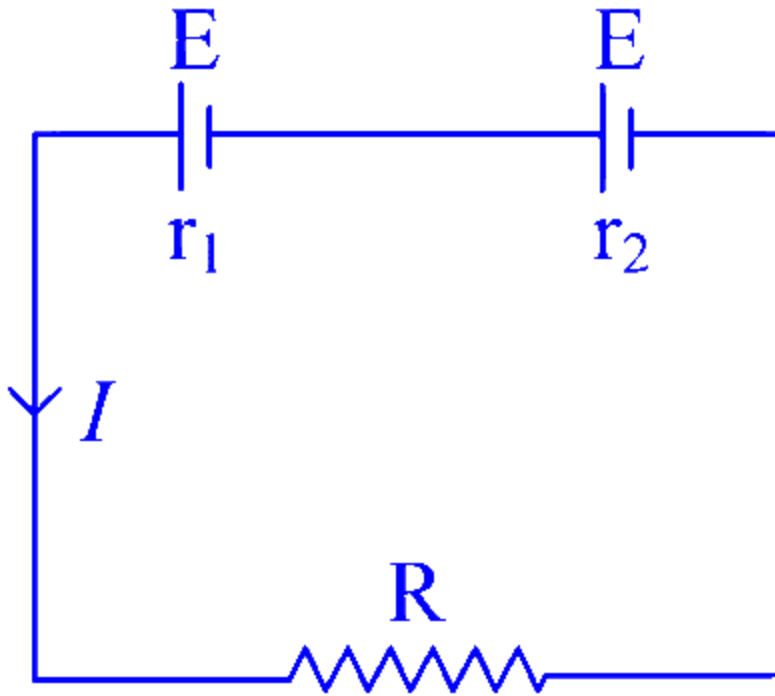

We have  $I(R + r_1 + r_2) = 2E$

Current in the circuit,  $I = \frac{2E}{R+r_1+r_2}$  .... (i)

Now, the potential difference across the first cell would be equal to  $V = E - Ir_1$ . From the question,  $V = 0$ , there

$$E = Ir_1 = \frac{2Er_1}{R+r_1+r_2} \quad [\text{From Eq. (i)}]$$

where,  $R + r_1 + r_2 = 2r_1$

Hence,  $R = r_1 - r_2$ .

## Question 164

**A string vibrates with a frequency of 200 Hz. When its length is doubled and tension is altered, it begins to vibrate with a frequency of 300 Hz. The ratio of the new tension to the original tension is**

**Options:**

A. 9 : 1

B. 1 : 9

C. 3 : 1

D. 1 : 3

**Answer: A**

**Solution:**

The frequency of a vibrating string can be expressed by the formula:

$$f = \frac{1}{2L} \sqrt{\frac{T}{\mu}}$$

Where:

- $f$  is the frequency of the string,
- $L$  is the length of the string,
- $T$  is the tension in the string, and
- $\mu$  is the linear mass density of the string.

Initially, the frequency of the string is 200 Hz when the length is  $L$  and the tension is  $T_1$ . The formula becomes:

$$200 = \frac{1}{2L} \sqrt{\frac{T_1}{\mu}}$$

When the length of the string is doubled to  $2L$  and the tension is altered to  $T_2$ , the frequency becomes 300 Hz. The formula then changes to:

$$300 = \frac{1}{4L} \sqrt{\frac{T_2}{\mu}}$$

We can rearrange each equation to express the square root of tension over linear mass density:

$$\sqrt{\frac{T_1}{\mu}} = 400L \quad \sqrt{\frac{T_2}{\mu}} = 1200L$$

Squaring both sides of each equation gives:

$$\frac{T_1}{\mu} = (400L)^2 \frac{T_2}{\mu} = (1200L)^2$$

Take the ratio  $\frac{T_2}{T_1}$ :

$$\frac{T_2}{T_1} = \frac{(1200L)^2}{(400L)^2} \frac{T_2}{T_1} = \left(\frac{1200}{400}\right)^2 \frac{T_2}{T_1} = (3)^2 \frac{T_2}{T_1} = 9$$

Thus, the ratio of the new tension  $T_2$  to the original tension  $T_1$  is 9:1, indicating that the new tension is 9 times greater than the original tension.

The correct answer is **Option A: 9 : 1**.

---

**Question 165**

**When  $10^{19}$  electrons are removed from a neutral metal plate, the electric charge on it is**

**Options:**

A.  $-1.6 \text{ C}$

B.  $+1.6 \text{ C}$

C.  $10^{+19} \text{ C}$

D.  $10^{-19} \text{ C}$

**Answer: B**

**Solution:**

Charge,  $q = ne$

$$\Rightarrow q = 10^{19} \times 1.6 \times 10^{-19} = 1.6 \text{ C}$$

---

## **Question 166**

**In an electrical circuit  $R, L, C$  and AC voltage source are all connected in series. When  $L$  is removed from the circuit, the phase difference between the voltage and the current in the circuit is  $\pi/3$ . If instead  $C$  is removed from the circuit, the phase difference is again  $\pi/3$ . The power factor of the circuit is**

**Options:**

A.  $1/2$

B.  $1\sqrt{2}$

C. 1

D.  $\frac{\sqrt{3}}{2}$

**Answer: C**



## Solution:

Here, phase difference

$$\tan \phi = \frac{X_L - X_C}{R} \Rightarrow \tan \frac{\pi}{3} = \frac{X_L - X_C}{R}$$

$$\text{When } L \text{ is removed, } \tan \frac{\pi}{3} = \frac{X_C}{R} = \sqrt{3}$$

$$\therefore X_C = \sqrt{3}R \dots (i)$$

Similarly, when  $C$  is removed

$$\tan \frac{\pi}{3} = \frac{X_L}{R} = \sqrt{3}$$

$$\Rightarrow X_L = \sqrt{3}R$$

$$\Rightarrow X_C = X_L \dots (ii) \text{ [from Eq. (i)]}$$

Now,  $\tan \phi = 0$

$$\Rightarrow \phi = 0^\circ$$

$$\therefore \text{Power factor, } \cos \phi = \cos 0^\circ = 1$$

---