

JEST-2024 Physics: Answer Key

Instructions for challenging a question/answer

1. Candidates who wish to challenge a question/answer may write to info.jest2024@iist.ac.in with “Question challenge” as the subject line.
2. Challenges from only those candidates who have appeared for the test will be entertained. Please mention your name and Roll No. alongwith.
3. The candidates must send in their challenges only from the email id registered with JEST 2024.
4. Challenges will be accepted till 23:59, March 6.

[For questions in Part A and Part B, the answer is Option A.]

Part A: 1-Mark MCQ

1. Three equal charges $+q$ are placed at the corners of an equilateral triangle. A test charge constrained to move on the plane of the triangle is placed at the centre of the triangle. Which of the following statements about the test charge is true?
 - A. Stability of the equilibrium depends on the sign of the test charge.**
 - B. It is in a stable equilibrium.
 - C. It is not in an equilibrium.
 - D. It is in an unstable equilibrium.

2. A classical system has the following action:

$$S = \int (\dot{q}^2 + \alpha q \dot{q} + \beta q^2 \dot{q}) dt ,$$

where q is the generalized coordinate, and α and β are constants. Which of the following statements is true about the dynamics of the system?

A. The dynamics is independent of α and β .

B. The dynamics depends only on α .

C. The dynamics depends only on β .

D. The dynamics depends on the ratio $\frac{\alpha}{\beta}$.

3. A and B are 2×2 Hermitian matrices. $|a_1\rangle$ and $|a_2\rangle$ are two linearly independent eigenvectors of A . Consider the following statements:

1. If $|a_1\rangle$ and $|a_2\rangle$ are eigenvectors of B , then $[A, B] = 0$.

2. If $[A, B] = 0$, then $|a_1\rangle$ and $|a_2\rangle$ are eigenvectors of B .

Mark the correct option.

A. Statement 1 is true but statement 2 is false.

B. Statement 2 is true but statement 1 is false.

C. Both statements 1 and 2 are true.

D. Both statements 1 and 2 are false.

4. An ideal gas initially at pressure P_i undergoes the following sequence of processes:

1. A reversible adiabatic expansion that doubles its volume.

2. A reversible isothermal compression that restores its original volume.

3. A reversible isothermal expansion that doubles its volume.

4. A reversible adiabatic compression that restores its original volume.

If the final pressure of the gas is P_f , which of the following is true?

A. $P_f = P_i$.

B. $P_f > P_i$.

C. $P_f < P_i$.

D. The relation between P_f and P_i depends on the initial conditions.

5. A quantum oscillator with energy levels

$$E_n = \left(n + \frac{1}{2}\right) \hbar\omega, \quad n = 0, 1, 2, \dots$$

is in equilibrium at a low enough temperature T so that the occupation of all states with $n \geq 2$ is negligible. What is the mean energy of the oscillator as a function of the inverse temperature $\beta = \left(\frac{1}{k_B T}\right)$?

A. $\hbar\omega \left[\frac{1}{2} + \frac{1}{1 + \exp(\beta\hbar\omega)} \right]$

B. $\hbar\omega \left[\frac{1}{2} + \frac{1}{1 - \exp(\beta\hbar\omega)} \right]$

C. $\hbar\omega \left[1 + \exp(-\beta\hbar\omega) \right]$

D. $\hbar\omega \left[1 - \exp(-\beta\hbar\omega) \right]$

6. A particle moving in one dimension has the wave function

$$\psi(x) = \exp \left[-\alpha \left(x - \frac{ik_0}{\alpha} \right)^2 \right] \sin^2(k_1 x),$$

where α is real positive and k_0, k_1 are real. The expectation value of momentum is

A. $2\hbar k_0$

B. 0

C. $\hbar k_0$

D. $\hbar k_1$

7. Two classical particles moving in three dimensions interact via the potential

$$V = K [(x_1^2 + y_1^2) + (x_2^2 + y_2^2) + (z_1 - z_2)^2],$$

where K is a constant, and (x_1, y_1, z_1) and (x_2, y_2, z_2) are the Cartesian coordinates of the two particles. Let (p_1^x, p_1^y, p_1^z) and (p_2^x, p_2^y, p_2^z) be the components of the linear momenta of the two particles, and (L_1^x, L_1^y, L_1^z) and (L_2^x, L_2^y, L_2^z) the components of the corresponding angular momenta. Which of the following statements is true?

- A. L_1^z, L_2^z , and $(p_1^z + p_2^z)$ are conserved.
- B. L_1^z and L_2^z are not separately conserved but $L_1^z + L_2^z$ is conserved.
- C. $(L_1^x + L_2^x), (L_1^y + L_2^y), (L_1^z + L_2^z)$ are conserved.
- D. $(L_1^x + L_2^x)$ and $(L_1^y + L_2^y)$ are conserved.
8. A cylindrical rigid block has principal moments of inertia I about the symmetry axis and $2I$ about each of the perpendicular axes passing through the center of mass. At some instant, the components of angular momentum about the center of mass in the body-fixed principal axis frame is (l, l, l) , with $l > 0$. What is the cosine of the angle between the angular momentum and the angular velocity?

- A. $\frac{2\sqrt{2}}{3}$
- B. $\frac{2}{\sqrt{6}}$
- C. $\frac{2}{3}$
- D. $\frac{5}{3\sqrt{3}}$

9. Consider a mass-pulley system as shown in the figure. The heights of the blocks as measured from the ceiling are x_1 and x_2 , as shown in the figure.

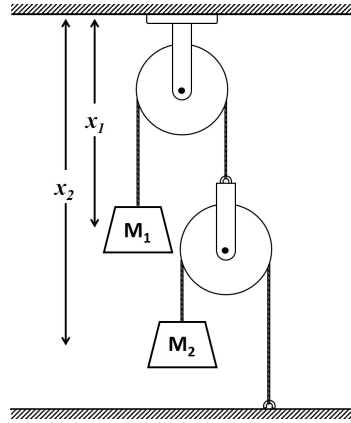

What is the constraint between x_1 and x_2 ?

- A. $x_2 + 2x_1 = \text{constant}$.
- B. $x_2 - x_1 = \text{constant}$.
- C. $x_2 + x_1 = \text{constant}$.
- D. They are unconstrained.
10. Let q and p be the canonical phase space coordinates of a system, where q is the generalized coordinate and p is the generalized momentum. Let us make a transformation of the generalized coordinate as $Q = q^2$. Which of the following functions is canonically conjugate to Q ?
- A. $\frac{p}{2q}$
- B. $\frac{p}{q}$
- C. p^2
- D. $\frac{p^2}{2q^2}$

11. A solid sphere of radius R has a volume charge density $\rho = \rho_0 \sin 2\theta$. How does the leading term in the electrostatic potential depend on the distance r far away from the charged sphere?

A. $\frac{1}{r^2}$

B. $\frac{1}{r}$

C. r

D. Does not depend on r

12. Let (G, \circ) be a discrete group of order 4 where the group operation ‘ \circ ’ among the various elements of $G = \{e, a, b, c\}$ is given by the following multiplication table:

	e	a	b	c
e	e	a	b	c
a	a	e	c	b
b	b	c	e	a
c	c	b	a	e

Which of the following is correct ?

A. (G, \circ) is non-cyclic and abelian.

B. (G, \circ) is cyclic and abelian.

C. (G, \circ) is cyclic and non-abelian.

D. (G, \circ) is non-cyclic and non-abelian.

13. Consider the Fourier transform of a function $f(x)$ defined as

$$g(p) = \int_{-\infty}^{\infty} f(x) \exp(ipx) dx, \quad \text{where } f(x) = \frac{1}{\sqrt{|x|}}.$$

Which of the following is the correct form of $g(p)$ for some constant β ?

A. $g(p) = \frac{\beta}{\sqrt{|p|}}$

B. $g(p) = \frac{\beta}{p}$

C. $g(p) = \frac{\beta}{p^2}$

D. $g(p) = \frac{\beta}{|p|}$

14. What is the power of a light source emitting photons of wavelength 600 nm at the rate of one photon per second? Planck's constant $h = 6.6 \times 10^{-34}$ Joule sec and speed of light $c = 3 \times 10^8$ m/sec.
- A. 3.3×10^{-19} W
 - B. 3.3×10^{-18} W
 - C. 6.0×10^{-19} W
 - D. 6.0×10^{-18} W
15. What is the right sequence of optical components to convert unpolarized light into circularly polarized light?
- A. **Light source \rightarrow linear polarizer \rightarrow quarter wave plate**
 - B. Light source \rightarrow quarter wave plate \rightarrow half wave plate
 - C. Light source \rightarrow linear polarizer \rightarrow half wave plate
 - D. Light source \rightarrow half wave plate \rightarrow quarter wave plate
16. Where does the Fermi level of an n-type semiconductor lie?
- A. **Near the conduction band minimum.**
 - B. Near the valence band maximum.
 - C. At the middle of the energy gap.
 - D. Inside the valence band.

17. A step index optical fiber has refractive indices $n_1 = 1.474$ for core region and $n_2 = 1.470$ for the cladding region. A ray of light is incident from air into the core through the cross section of the fiber at an angle θ with the normal. What is the limiting value of θ below which the light ray will be totally internally reflected? Refractive index of air is taken as 1.

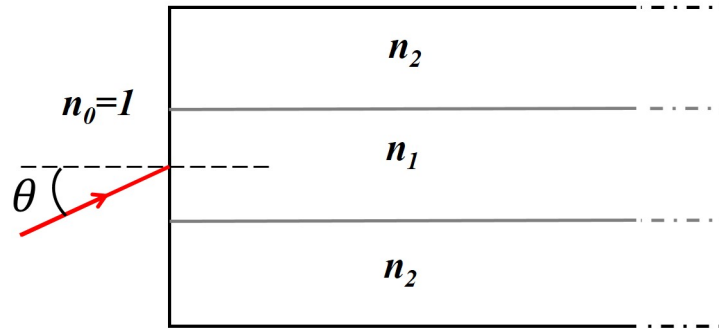

- A. 6.229°
 B. 58.194°
 C. 2.862°
 D. 4.222°
18. A satellite of mass 2000 kg is placed in an elliptic orbit around Earth with semi major axis A . Assume that the total energy of the orbiting satellite is E and the angular momentum is L . Through a series of manoeuvres, the elliptic orbit is changed to a circular orbit with radius A . For the orbit change described, which of the following is true?
- A. E does not change, but L changes.
 B. E changes, but L does not change.
 C. Both E and L change.
 D. Neither E nor L changes.

19. Which of the following functions is not a valid thermodynamic function of internal energy U in terms of entropy S , volume V , and number of particles N ? Here U_0 , α , β , A , B and C are constants.

A. $U_0 \exp\left(\frac{\alpha V^2 N}{S^2}\right)$

B. $\left(\frac{AV^2}{N}\right) \exp\left(\frac{\beta VN}{S^2}\right)$

C. $\frac{BS^2V^2}{N^3}$

D. $\frac{CN^2}{\sqrt{SV}}$

20. What is the output waveform of the circuit for the given input signal? Assume that the zener diodes are identical, amplitude of the input voltage V_{in} is twice the zener breakdown voltage, and $R_L = 10R$.

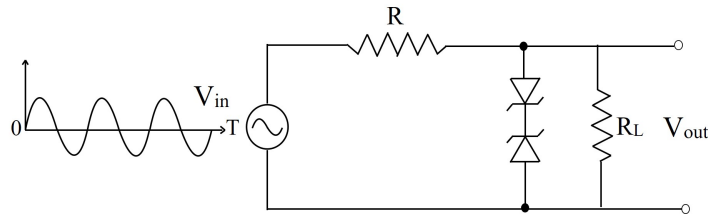

A.

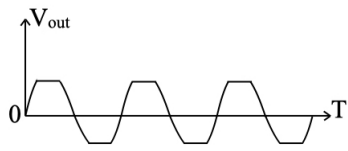

B.

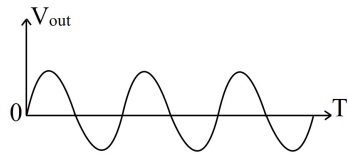

C.

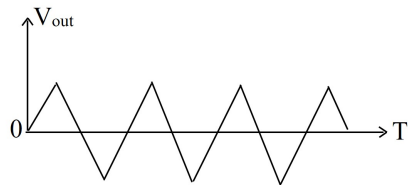

D.

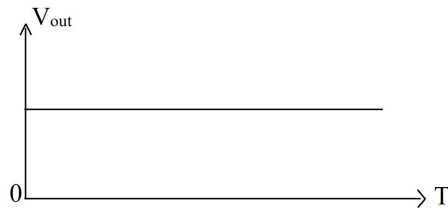

21. Given that the latent heat of liquefaction is 80 Cal/g, what is the change in entropy when 10 g of ice at 0°C is converted into water at the same temperature?

- A. 2.93 Cal K⁻¹
- B. 3.42 Cal K⁻¹
- C. 2.0 Cal K⁻¹
- D. 4.5 Cal K⁻¹

22. Consider a system of N noninteracting spin- $\frac{1}{2}$ atoms subjected to a magnetic field with the Hamiltonian given by

$$H = -g\mu_B B \sum_{i=1}^N S_i^z ,$$

where g is the dimensionless Landé factor, μ_B is the Bohr magneton, B is the strength of the magnetic field, and S_i^z is the z -component of the spin of the i th atom (S_i^z takes values $\pm\frac{1}{2}$). The system is in equilibrium at temperature T . What is the probability that the z -component of the spins corresponding to two given atoms have the same value? Take $\beta = \frac{1}{k_B T}$, where k_B is the Boltzmann constant.

- A. $\frac{\exp(-\beta g\mu_B B) + \exp(\beta g\mu_B B)}{2 + \exp(-\beta g\mu_B B) + \exp(\beta g\mu_B B)}$
- B. $\frac{\exp(-\beta g\mu_B B)}{2 + \exp(-\beta g\mu_B B) + \exp(\beta g\mu_B B)}$
- C. $\frac{\exp(\beta g\mu_B B)}{2 + \exp(-\beta g\mu_B B) + \exp(\beta g\mu_B B)}$
- D. $\frac{1}{4}$

23. Two electrons have orbital angular momentum quantum numbers $l_1 = 3$ and $l_2 = 2$, respectively. Let $L^z = L_1^z + L_2^z$, where L_1^z and L_2^z are the z -components of the respective angular momentum operators. How many linearly independent states have L^z quantum number $m = 2$?

- A. 4
- B. 3
- C. 11
- D. 0

24. A quantum particle is subjected to the potential $V(x) = ax + bx^2$, where a and b are constants. What is the mean position of the particle in the first excited state?

A. $-\frac{a}{2b}$

B. $\frac{a}{2b}$

C. $-\frac{a}{b}$

D. $\frac{a}{b}$

25. The density of states of a system of N particles at energy E is

$$g(E, N) = \begin{cases} \frac{1}{(\hbar\omega)^N} \frac{E^{N-1}}{(N-1)!} & \text{for } E \geq 0 \\ 0 & \text{for } E < 0 \end{cases}$$

where \hbar is the Planck's constant and ω is a natural frequency of the system. Taking k_B to be the Boltzmann constant, compute the temperature of the system at energy E .

A. $\frac{E}{Nk_B}$

B. $\frac{1}{k_B} \left(\frac{E}{N} + \frac{1}{2}\hbar\omega \right)$

C. $\frac{1}{k_B} \left(\frac{E}{N} + \hbar\omega \right)$

D. $\frac{1}{k_B} \sqrt{\left(\frac{E}{N} \right)^2 + (\hbar\omega)^2}$

Part B: 3-Mark MCQ

1. The energy spectrum for a system of spinless noninteracting fermions consists of $(N + 1)$ nondegenerate energy levels $0, \varepsilon, 2\varepsilon, \dots, N\varepsilon$ ($\varepsilon > 0$). Let $x = \exp\left(-\frac{\varepsilon}{k_B T}\right)$, where k_B is the Boltzmann constant and T is the temperature. For N identical fermions in thermal equilibrium at temperature T , what is the average occupancy of the highest energy level?

A. $\frac{x - x^{N+1}}{1 - x^{N+1}}$

B. $\frac{x - x^{N+1}}{1 + x^{N+1}}$

C. $\frac{x}{1 - x^N}$

D. $\frac{x^N}{1 + x^N}$

2. A two-level quantum system has the Hamiltonian

$$H = \hbar\omega_0 \begin{pmatrix} 0 & 1 \\ 1 & 0 \end{pmatrix}.$$

At $t = 0$, the system is in the state

$$|\psi(0)\rangle = \begin{pmatrix} 1 \\ 0 \end{pmatrix}.$$

What is the earliest time $t > 0$ at which a measurement of

$$\sigma_z = \begin{pmatrix} 1 & 0 \\ 0 & -1 \end{pmatrix}$$

will yield the value -1 with probability one?

A. $\frac{\pi}{2\omega_0}$

B. $\frac{2\pi}{\omega_0}$

C. $\frac{\pi}{\omega_0}$

D. Never

3. The singular matrix

$$A = \begin{pmatrix} 2 & 3 & 3 \\ 3 & 6 & 3 \\ 3 & 3 & 6 \end{pmatrix}$$

commutes with the matrix

$$B = \begin{pmatrix} 1 & 0 & 0 \\ 0 & 0 & 1 \\ 0 & 1 & 0 \end{pmatrix}.$$

The eigenvalues of A are

- A. $(0, 3, 11)$
- B. $(0, 3, 13)$
- C. $(0, 0, 12)$
- D. $(0, 2, 5)$

4. A polynomial $C_n(x)$ of degree n defined on the domain $x \in [-1, 1]$ satisfies the differential equation

$$(1 - x^2) \frac{d^2 C_n}{dx^2} - x \frac{dC_n}{dx} + n^2 C_n = 0.$$

The polynomials satisfy the orthogonality relation

$$\int_{-1}^1 \sigma(x) C_n(x) C_m(x) dx = 0$$

for $n \neq m$. What is $\sigma(x)$?

- A. $(1 - x^2)^{-1/2}$
- B. $(1 - x^2)$
- C. 1
- D. $\exp(-x^2)$

5. Consider a particle of mass m and nonzero angular momentum ℓ subjected to a central force potential $V(r) = k \ln r$, where k is a positive constant. What is the radius R at which it can have a circular orbit? Will the circular orbit be stable or unstable?

A. $R = \frac{\ell}{\sqrt{km}}$ and stable.

B. $R = \frac{\ell}{\sqrt{km}}$ and unstable.

C. $R = \frac{\ell}{\sqrt{2km}}$ and stable.

D. $R = \frac{\ell}{\sqrt{2km}}$ and unstable.

6. Consider a particle of mass m moving in a three-dimensional delta-function potential well $V(\vec{r}) = -\alpha\delta^3(\vec{r})$, where $\alpha > 0$. Which of the following is an allowed expression for the energy of a bound state for some dimensionless proportionality constant $\beta > 0$?

A. $-\frac{\beta\hbar^6}{\alpha^2 m^3}$

B. $\frac{\beta\hbar^6}{\alpha^2 m^3}$

C. $-\frac{\beta\alpha^2 m}{\hbar^2}$

D. $\frac{\beta\alpha^2 m}{\hbar^2}$

7. A particle with energy $E > 0$ is incident from the right ($x > 0$) on a one-dimensional potential composed of a delta-function barrier at $x = 0$ and a hard wall at $x = -a$:

$$V(x) = \begin{cases} \alpha \delta(x), & x > -a \\ \infty, & x \leq -a \end{cases}$$

where $\alpha > 0$ and $a > 0$. Let us define $\kappa^2 = \frac{2mE}{\hbar^2}$ and the dimensionless quantities: $\xi = \kappa a$ and $\beta = \frac{\hbar^2}{2m\alpha a}$. For some energy E the particle reflects from the barrier without any phase shift. Which of the following transcendental equations determines this energy? [Note that in the presence of the delta function barrier, the derivative of the wave function has a discontinuity at $x = 0$: $\psi'(0^+) - \psi'(0^-) = \frac{\psi(0)}{\beta a}$.]

- A. $\tan \xi = -\beta\xi$
- B. $\tan \xi = \beta\xi$
- C. $\tanh \xi = \beta\xi$
- D. $\tanh \xi = -\beta\xi$

8. The speed distribution of the molecules of an ideal gas in equilibrium at inverse temperature $\beta (= \frac{1}{k_B T})$ is found to obey the Maxwell distribution:

$$P(v) = C v^2 \exp\left(-\frac{1}{2}\beta m v^2\right)$$

where m is the mass of a molecule and C is a normalization constant. Compute $(\langle v^4 \rangle)^{1/4}$.

- A. $\sqrt{\frac{\sqrt{15}k_B T}{m}}$
- B. $\sqrt{\frac{4k_B T}{m}}$
- C. $\sqrt{\frac{3k_B T}{m}}$
- D. $\sqrt{\frac{11k_B T}{\pi m}}$

9. A classical particle undergoing simple harmonic motion is confined to the region $(-a, a)$ on the X -axis. If a snapshot of the particle is taken at a random instant of time, what is the probability that it would be found in the region $(\frac{a}{2}, a)$?

A. $\frac{1}{3}$

B. $\frac{1}{6}$

C. $\frac{1}{4}$

D. $\frac{2}{5}$

10. The ratio of the molar specific heats of an ideal gas is $\gamma = \frac{c_p}{c_v} = \frac{3}{2}$. It undergoes a reversible isothermal expansion in which its volume doubles. Next, it undergoes a reversible isochoric process such that the change in entropy of the second process is equal to the change in entropy of the first process. What is the ratio of the final temperature to the initial temperature?

A. $\sqrt{2}$

B. 2

C. 3

D. $\frac{3}{2}$

11. Two trains, each having proper length L_0 are moving towards each other with the same speed v but in opposite directions as measured by an observer in an inertial frame. What is the length of one of the trains as measured by an observer in the other train?

A. $L_0 \left(\frac{c^2 - v^2}{c^2 + v^2} \right)$

B. $L_0 \sqrt{\left(\frac{c^2 - v^2}{c^2 + v^2} \right)}$

C. $L_0 \sqrt{1 - \frac{v^2}{4c^2}}$

D. $L_0 \sqrt{1 - \frac{v^2}{c^2}}$

12. An infinitely long cylinder of radius R has uniform volume charge density. A spherical region of radius R is carved out of it, as shown in the figure. At what value of r (the radial coordinate in a cylindrical system, with origin at the center of the sphere) is the electric field maximum?

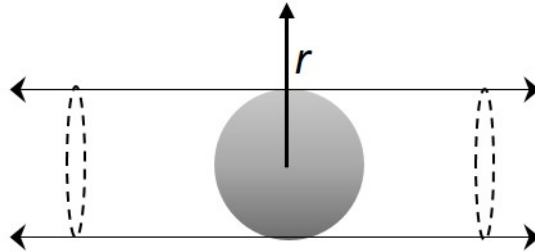

- A. $r = \frac{4}{3}R$
- B. $r = R$
- C. $r = \frac{2}{3}R$
- D. $r = \frac{3}{2}R$

13. What is the output of the following logic circuit?

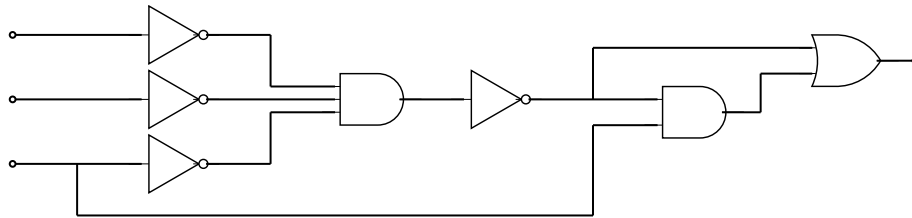

- A. $X = A \text{ AND } B \text{ AND } C$
- B. $X = (A \text{ OR } C) \text{ AND } (B \text{ OR } C)$
- C. $X = (A \text{ OR } C) \text{ AND } (B \text{ OR } C) \text{ AND } C$
- D. $X = (\bar{A} \text{ OR } \bar{B} \text{ OR } \bar{C}) \text{ AND } C$

This question is withdrawn since the labels are not shown in the figure. ALL CANDIDATES WILL BE AWARDED 3 MARKS.

14. What is the value of $\int_0^{\infty} \frac{dx}{1+x^3}$?

A. $\frac{2\pi}{3\sqrt{3}}$

B. $\frac{\pi}{3\sqrt{3}}$

C. $\frac{2\pi}{\sqrt{3}}$

D. $\frac{\pi}{3}$

15. What is the output voltage V_o and current I in the $10\text{ k}\Omega$ resistance of the following circuit? $V_i = 0.5\text{ V}$.

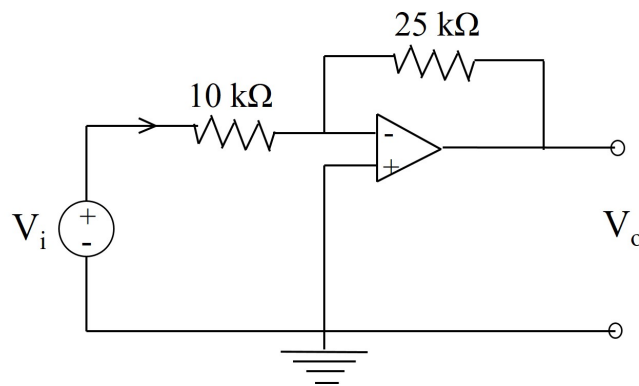

A. $V_o = -1.25\text{ V}$, $I = 50\ \mu\text{A}$

B. $V_o = -0.4\text{ V}$, $I = 50\ \mu\text{A}$

C. $V_o = -0.4\text{ V}$, $I = 20\ \mu\text{A}$

D. $V_o = -1.25\text{ V}$, $I = 20\ \mu\text{A}$

Part C: 3-Mark Numerical

1. A system of two noninteracting identical bosons is in thermal equilibrium at temperature T . The particles can be in one of three states with nondegenerate energy eigenvalues $-\varepsilon, 0$ and ε . The temperature T is such that $\exp\left(-\frac{\varepsilon}{k_B T}\right) = \frac{1}{2}$, where k_B is the Boltzmann's constant. The average energy of the system is found to be $\langle E \rangle = -\frac{n}{35}\varepsilon$, where n is an integer. What is the value of n ?

Answer: 36

2. A semi-infinite, thin wire extending from $-\infty$ to zero along the z -axis carries a constant current I in the positive z -direction. The wire is charge-neutral except at $z = 0$, where the inflowing charge is accumulated. What is the absolute value of the line integral $\frac{4}{\mu_0 I} \oint \vec{B} \cdot d\vec{l}$ along the circle $x^2 + y^2 = 1$? \vec{B} is the magnetic field and μ_0 is the permeability in free space. Assume that the accumulated charge at $z = 0$ is a point charge.

Answer: 2

3. Consider the rotation matrix

$$R = \begin{pmatrix} 2/3 & -1/3 & 2/3 \\ 2/3 & 2/3 & -1/3 \\ -1/3 & 2/3 & 2/3 \end{pmatrix}.$$

Let ϕ be the angle of rotation. What is the value of $\sec^2 \phi$?

Answer: 4

4. A quantum harmonic oscillator of mass m and angular frequency ω is in the state $|\psi\rangle = \frac{1}{\sqrt{2}}(|287\rangle + |288\rangle)$, where $|n\rangle$ denotes the n^{th} normalized energy eigenstate of the harmonic oscillator. Let $L_0 = \sqrt{\frac{\hbar}{m\omega}}$ denote the oscillator size and $\langle \hat{x} \rangle$ denote the expectation value of the position operator in the state $|\psi\rangle$. What is the value of $\frac{\langle \hat{x} \rangle}{L_0}$? You may use the form of the position operator in terms of the raising and lowering operators: $\hat{x} = \frac{L_0}{\sqrt{2}}(a + a^\dagger)$.

Answer: 12

5. A quantum mechanical particle of mass m is confined in a one dimensional infinite potential well whose walls are located at $x = 0$ and $x = 1$. The wave function of the particle inside the well is $\psi(x) = \mathcal{N}[x \ln x + (1-x) \ln(1-x)]$ for some normalization constant \mathcal{N} . An experimentalist measures the position of the particle on an ensemble of a large number of identical systems in the same state. The mean of the outcomes is found to be $\frac{1}{n}$, where n is an integer. What is n ?

Answer: 2

6. A point mass m constrained to move along the X -axis is under the influence of gravitational attraction from two point particles each of mass M fixed at the points $(x = 0, y = a)$ and $(x = 0, y = -a)$. Find the time period of small oscillations of the mass m in units of $\pi\sqrt{\frac{a^3}{8GM}}$, where G is the universal gravitational constant.

Answer: 4

7. The radial part of the electronic ground state wave function of the Hydrogen atom is

$$R_{10}(r) = \frac{1}{\sqrt{\pi a_0^3}} \exp\left(-\frac{r}{a_0}\right),$$

where a_0 is the Bohr radius. If $\langle r \rangle$ and r_{mp} denote the expectation value and the maximum probable value of the radial coordinate, respectively, compute $\frac{8 \langle r \rangle}{3 r_{mp}}$.

Answer: 4

8. A magnetic vector potential is given as $\vec{A} = 6\hat{i} + yz^2\hat{j} + (3y + z)\hat{k}$. Find the corresponding outgoing magnetic flux through the five faces (excluding the shaded one) of a unit cube with one corner at the origin, as shown in the figure.

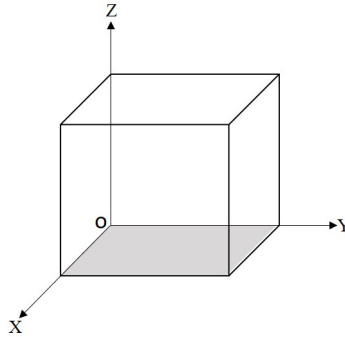

Answer: 0

9. In an intrinsic semiconductor at 300 K, the number density of electrons is $n_e = 2.5 \times 10^{20} \text{ m}^{-3}$. If the mobility of electrons is $\mu_e = 0.4 \text{ m}^2\text{V}^{-1}\text{s}^{-1}$ and the mobility of holes is $\mu_h = 0.2 \text{ m}^2\text{V}^{-1}\text{s}^{-1}$, find the conductivity in units of mho/m. Charge of a proton $e = 1.6 \times 10^{-19} \text{ Coulomb}$.

Answer: 24

10. An object of height 10 mm is located 150 mm to the left of a thin lens of focal length +50 mm. A second thin lens of focal length -100 mm is to be placed to the right of the first lens such that the real image of the object is located 100 mm to the right of the second lens. What should be the separation in mm between the two lenses?

Answer: 25