

PHYSICS
PAPER 1
(THEORY)

Maximum Marks: 70

Time Allowed: Three Hours

*(Candidates are allowed additional 15 minutes for only reading the paper.
They must NOT start writing during this time.)*

This paper is divided into four sections – A, B, C and D.

Answer all questions.

Section A consists of one question having sub-parts of one mark each.

Section B consists of seven questions of two marks each.

Section C consists of nine questions of three marks each, and

Section D consists of three questions of five marks each.

*Internal choices have been provided in two questions each in Section B,
Section C and Section D.*

The intended marks for questions are given in brackets [].

*All working, including rough work, should be done on the same sheet as and
adjacent to the rest of the answer.*

Answers to sub parts of the same question must be given in one place only.

A list of useful physical constants and relations is given at the end of this paper.

A simple scientific calculator without a programmable memory may be used for calculations.

SECTION A – 14 MARKS

Question 1

(A) In questions (i) to (vii) given below, choose the correct alternative (a), (b), (c) or (d) for each of the questions.

- (i) If potential difference between the two ends of a metallic wire is doubled, [1]
drift speed of free electrons in the wire:
- (a) remains same.
 - (b) becomes double.
 - (c) becomes four times.
 - (d) becomes half.

This Paper consists of 11 printed pages and one blank page.

1224-861A

© Copyright reserved.

Turn over

(ii) A **metre bridge** is balanced with a known resistance (R) in the left hand gap and an unknown resistance (S) in the right hand gap. Balance point is found to be at a distance of l cm from the left hand side. When the battery and the galvanometer are interchanged, balance point will [1]

- (a) shift towards left.
- (b) shift towards right.
- (c) remain same.
- (d) shift towards left or right depending on the values of R and S.

(iii) **Lorentz force** in vector form is: [1]

- (a) $F = B q v \sin \theta$
- (b) $\vec{F} = q (\vec{v} \times \vec{B})$
- (c) $\vec{F} = q (\vec{B} \times \vec{v})$
- (d) $\vec{F} = \vec{v} (q \times \vec{B})$

(iv) **Assertion:** When an electric current is passed through a moving coil galvanometer, its coil gets deflected. [1]

Reason: A circular coil produces a uniform magnetic field around itself when an electric current is passed through it.

- (a) Both Assertion and Reason are true and Reason is the correct explanation for Assertion.
- (b) Both Assertion and Reason are true but Reason is not the correct explanation for Assertion.
- (c) Assertion is true and Reason is false.
- (d) Assertion is false and Reason is true.

(v) When a ray of **white** light is incident obliquely on the first surface of a prism, [1] then

- (a) red colour is deviated most.
- (b) green colour is deviated most.
- (c) yellow colour is deviated most.
- (d) violet colour is deviated most.

- (vi) The **de-Broglie** wavelength (λ) associated with a moving electron having kinetic energy (E) is given by: [1]

(a) $\frac{2h}{\sqrt{2mE}}$

(b) $\frac{2\sqrt{2mE}}{h}$

(c) $\frac{h}{\sqrt{2mE}}$

(d) $\sqrt{2mhE}$

- (vii) The **majority** charge carriers in a **P**-type semiconductor are [1]

(a) electrons.

(b) holes.

(c) protons.

(d) ions.

- (B) Answer the following questions **briefly**.

(i) In an electric dipole, what is the **locus** of a point having zero potential? [1]

(ii) Three identical cells each of emf 'e' are connected in **parallel** to form a battery. What is the emf of the battery? [1]

(iii) Three bulbs **B**₁(230V, 40W), **B**₂(230V, 60W) and **B**₃(230V, 100W) are connected in **series** to a 230V supply. Which bulb glows the brightest? [1]

(iv) Explain the meaning of the following statement: **Curie** temperature for soft iron is 770°C. [1]

(v) What type of wavefronts are associated with a **point source** of light? [1]

(vi) What is '**Pair production**'? [1]

(vii) In semiconductor physics, what is the **function** of a rectifier? [1]

SECTION B – 14 MARKS

Question 2

[2]

- (i) A hollow sphere of radius R has a point charge q at its centre. **Electric flux** emanating from the sphere is X . How will the electric flux change, if at all, when
- radius of the sphere is **doubled**?
 - charge q is **replaced** by an electric dipole?

OR

- (ii) In case of an **infinite line charge**, how does intensity of electric field at a point change, if at all, when
- charge on it is **doubled**?
 - distance of the point is **halved**?

Question 3

[2]

- What is meant by the statement: “**Relative permittivity** of water is 81”?
- Can a body be given a charge of $2.2 \times 10^{-19} \text{ C}$? Give a reason for your answer.

Question 4

[2]

- What **type** of transformer is used in a mobile phone charger?
- Why is the **core of a transformer** made of soft iron and not of steel?

Question 5

[2]

- Name the electromagnetic radiation whose frequency is 10^{11} Hz .
- What is the speed of radio waves in **vacuum**?

Question 6

[2]

Draw a **labelled** graph showing the variation in **intensity of diffracted light** with diffracting angle in a single slit **Fraunhofer diffraction** experiment.

Question 7

[2]

(i) *Figure 1* below is the Energy level diagram for Hydrogen atom. Study the transitions shown and answer the following questions.

- (a) State the type of spectrum obtained.
- (b) Name the series of spectrum obtained.

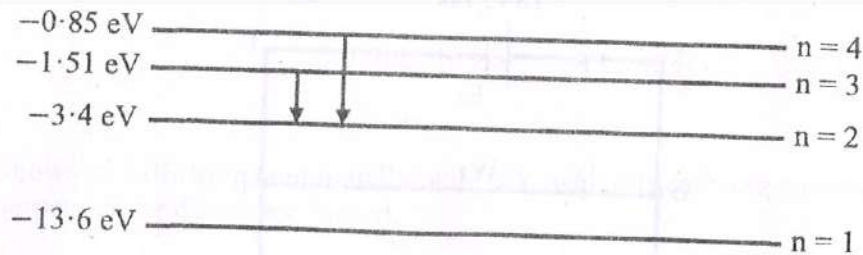

Figure 1

OR

(ii) In a **nuclear reactor**, state the use of the following:

- (a) Graphite rods
- (b) Cadmium rods

Question 8

[2]

With reference to a semiconductor diode, define the following terms:

- (i) depletion region
- (ii) potential barrier

SECTION C – 27 MARKS

Question 9

[3]

Obtain an expression for **equivalent** capacitance C when three capacitors C_1 , C_2 and C_3 are connected in **series**.

Question 10

[3]

- (i) *Figure 2* below shows two batteries E_1 and E_2 having emfs of 18V and 10V and internal resistances of 1Ω and 2Ω respectively. W_1, W_2 and W_3 are uniform metallic wires AC, FD and BE having resistance of $8\Omega, 6\Omega$ and 10Ω respectively. B and E are **midpoints** of the wires W_1 and W_2 . Using **Kirchhoff's** laws of electrical circuits, calculate the current flowing in the wire W_3 .

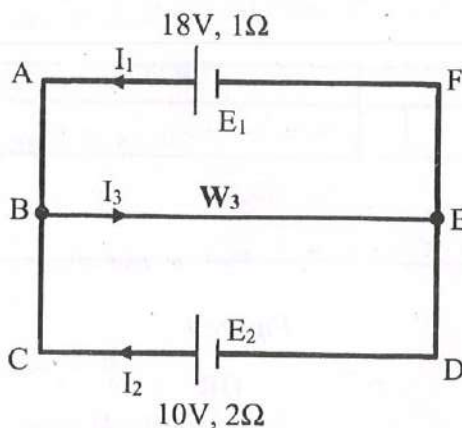

Figure 2

OR

- (ii) *Figure 3* below shows a **potentiometer** circuit in which the **driver cell D** has an emf of 6V and internal resistance of 2Ω . The potentiometer wire AB is 10m long and has a resistance of 28Ω . The series resistance R_s is of 20Ω .

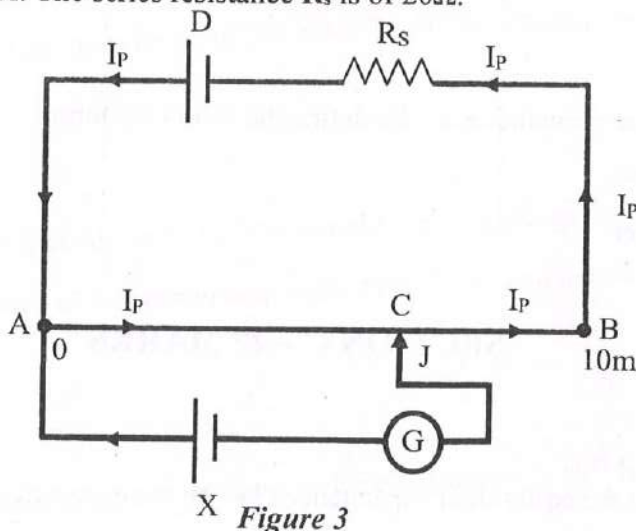

Figure 3

Calculate:

- The current I_p flowing in the potentiometer wire AB when the jockey (J) **does not touch** the wire AB.
- emf of the cell X if the **balancing length** AC is 4.5m.

Question 11

[3]

Using **Biot-Savart law**, show that **magnetic flux density 'B'** at the centre of a current carrying circular coil of radius R is given by:

$$B = \frac{\mu_0 I}{2R}$$

where the terms have their usual meaning.

Question 12

[3]

Figure 4 below shows an **infinitely long** metallic wire YY' which is carrying a current I' . P is a point at a perpendicular distance r from it.

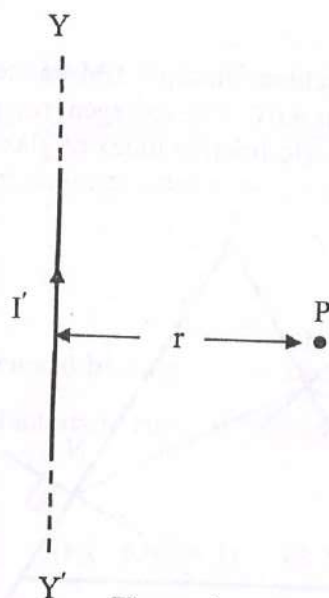

Figure 4

- (i) What is the **direction** of magnetic flux density B of the magnetic field at the point P ?
- (ii) What is the **magnitude** of magnetic flux density B of the magnetic field at the point P ?
- (iii) Another metallic wire MN having length l and carrying a current I is **now** kept at the point P . If the two wires are in vacuum and parallel to each other, how much **force** acts on the wire MN due to the current I' flowing in the wire YY' ?

Question 13

[3]

- (i) Using **Huygen's wave theory**, show that (for refraction of light):

$$\frac{\sin i}{\sin r} = \text{Constant}$$

where terms have their usual meaning. You must draw a neat and **labelled** diagram.

OR

- (ii) In **Young's double slit experiment**, show that:

$$\beta = \frac{\lambda D}{d}$$

where the terms have their usual meaning.

Question 14

[3]

Figure 5 below shows a ray of monochromatic light LM incident on the first surface AB of a **regular (equilateral) glass prism** ABC. The emergent ray grazes the adjacent surface AC. Calculate the **angle of incidence**. (Refractive Index of glass = 1.5)

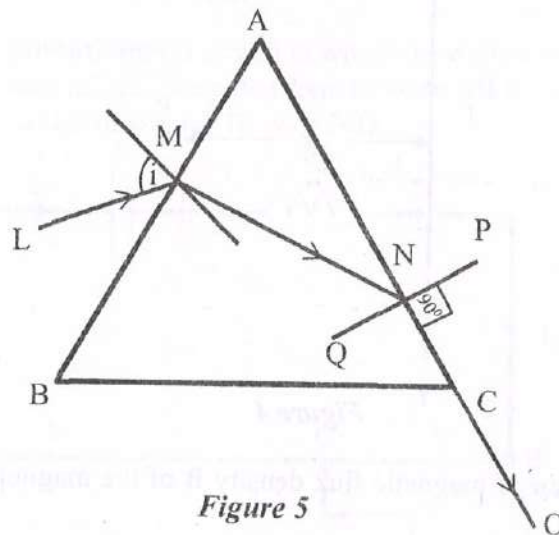

Figure 5

Question 15

[3]

A student is performing an experiment to determine **focal length** of a convex lens by using lens formula i.e., by **no parallax** method. The examiner gives some instructions to the student. The student responds to each instruction as per her understanding of the experiment.

State whether the student's response is correct or incorrect. Give a reason for your answer.

- (i) EXAMINER: Image formed by the lens is **magnified**. Reduce the size of the image.
STUDENT moves the lens towards the object pin.
- (ii) EXAMINER: Plot a graph of $(1/v)$ **against** $(1/u)$.
STUDENT takes $(1/v)$ on Y axis and $(1/u)$ on X axis.
- (iii) EXAMINER: Write the relation between the **optical power** (P) and the **focal length** (f) of the convex lens.
STUDENT writes $P = 2f$.

Question 16

[3]

- (i) In an experiment on photo electric effect, how does **stopping potential** change, if at all, when **intensity** of incident monochromatic UV radiation is increased?
- (ii) Ultraviolet light is incident on metals P, Q and R, having work functions 8eV, 2eV and 4eV respectively.
- (a) Which metal has **lowest** threshold frequency for photoelectric effect?
- (b) For which metal is the value of E_{\max} **minimum**?
- (Note: E_{\max} is maximum kinetic energy of the emitted photoelectrons.)

Question 17

[3]

- (i) What is meant by **forward biasing** of a semiconductor diode?
- (ii) Draw a **labelled** characteristic curve (I-V graph) for a semiconductor diode during **forward bias**.

SECTION D – 15 MARKS

Question 18

[5]

- (i) (a) A 220V, 50Hz ac source is connected to a coil having coefficient of self-inductance of 1H and a resistance of 400 Ω . Calculate:
- (1) the **reactance** of the coil.
- (2) the **impedance** of the coil.
- (3) the **current** flowing through the coil.
- (b) Draw a **labelled** graph showing variation of **impedance** (Z) of a series LCR circuit Vs **frequency** (f) of the ac supply. Mark the resonant frequency as f_0 .

OR

- (ii) (a) When current flowing through a solenoid decreases from 5A to 0 in 20 milliseconds, an emf of 500V is induced in it.
- (1) What is this phenomenon called?
 - (2) Calculate **coefficient of self-inductance** of the solenoid.
- (b) (1) **RMS** value of an alternating current flowing in a circuit is 5A. Calculate its **peak** value.
- (2) State **any one** difference between a direct current (dc) and an alternating current (ac).

Question 19

[5]

- (i) (a) On the basis of **Bohr's theory**, derive an expression for the **radius** of the n^{th} orbit of an electron of hydrogen atom.
- (b) Calculate the energy released in the following nuclear fusion reaction:

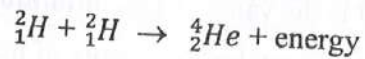

$$\text{Mass of } {}^2_1\text{H} = 2.014102\text{u}$$

$$\text{Mass of } {}^4_2\text{He} = 4.002604\text{u}$$

OR

- (ii) (a) Calculate **mass defect** and **binding energy** of ${}^{20}_{10}\text{Ne}$ nucleus, given

$$\text{Mass of } {}^{20}_{10}\text{Ne} = 19.992397\text{u},$$

$$\text{Mass of } {}^1_1\text{H} = 1.007825\text{u},$$

$$\text{Mass of } {}^1_0\text{n} = 1.008665\text{u}.$$

- (b) State the **Bohr's postulate** of angular momentum of an electron.

(c)

- (1) What is the **velocity** of an electron in the 3rd orbit of hydrogen atom if its velocity in the 1st orbit is v_0 ?
- (2) Radius of the 1st orbit of hydrogen atom is r_0 . What will be the **radius** of the 4th orbit?

Question 20

[5]

Read the passage given below and answer the questions that follow.

There are two types of optical instruments: Microscopes and Telescopes. Microscopes are used to magnify very tiny objects whereas telescopes are used to study distant objects. Both of them deploy convex lenses. In his telescope, **Newton** used a large parabolic mirror to collect light from the stars and reduce aberrations.

- (i) Rohit observed the launch of **Chandrayan 3** with the help of an optical instrument. Name the instrument used by him.
- (ii) State **any one** advantage of a reflecting telescope over a refracting telescope.
- (iii) Which instrument is used to study the structure of a virus?
- (iv) What is the ability of an optical instrument to form enlarged images called?
- (v) What is the **difference** between a compound microscope and an astronomical telescope (refracting type), as far as their **lenses** are concerned?

Useful Constants & Relations:

1.	Charge of a proton	e	$1.6 \times 10^{-19} \text{ C}$
2.	Speed of light in vacuum	c	$3 \times 10^8 \text{ ms}^{-1}$
3.		1u =	931MeV