

DAY — 09

SEAT NUMBER

--	--	--	--	--	--

2024	III	02	1100	J-862	(E)
MATHEMATICS & STATISTICS (40) (ARTS & SCIENCE)					
Time : 3 Hrs.		(8 Pages)		Max. Marks : 80	

General instructions :

The question paper is divided into **FOUR** sections.

- (1) **Section A:** Q. 1 contains **Eight** multiple choice type of questions, each carrying **Two** marks.
Q. 2 contains **Four** very short answer type questions, each carrying **One** mark.
- (2) **Section B:** Q. 3 to Q. 14 contain **Twelve** short answer type questions, each carrying **Two** marks. (Attempt any **Eight**)
- (3) **Section C:** Q. 15 to Q. 26 contain **Twelve** short answer type questions, each carrying **Three** marks. (Attempt any **Eight**)
- (4) **Section D:** Q. 27 to Q. 34 contain **Eight** long answer type questions, each carrying **Four** marks. (Attempt any **Five**)
- (5) Use of log table is allowed. Use of calculator is not allowed.
- (6) Figures to the right indicate full marks.
- (7) Use of graph paper is not necessary. Only rough sketch of graph is expected.
- (8) For each multiple choice type of question, only the first attempt will be considered for evaluation.
- (9) Start answer to each section on a new page.

0	8	6	2
---	---	---	---

SECTION - A

Q. 1. Select and write the correct answer for the following multiple choice type of questions :

[16]

(i) The dual of statement $r \vee (p \vee q)$ is _____.

- (a) $c \wedge (p \vee q)$ (b) $c \wedge (p \wedge q)$
 (c) $r \wedge (p \wedge q)$ (d) $r \wedge (p \vee q)$ (2)

(ii) The principle solutions of the equation $\cos \theta = \frac{1}{2}$ are _____.

- (a) $\frac{\pi}{6}, \frac{5\pi}{6}$ (b) $\frac{\pi}{3}, \frac{5\pi}{3}$
 (c) $\frac{\pi}{6}, \frac{7\pi}{6}$ (d) $\frac{\pi}{3}, \frac{2\pi}{3}$ (2)

(iii) If α, β, γ are direction angles of a line and $\alpha = 60^\circ, \beta = 45^\circ$, then $\gamma =$ _____.

- (a) 30° or 90° (b) 45° or 60°
 (c) 90° or 130° (d) 60° or 120° (2)

(iv) The perpendicular distance of the plane $\vec{r} \cdot (3\hat{i} + 4\hat{j} + 12\hat{k}) = 78$, from the origin is _____.

- (a) 4 (b) 5
 (c) 6 (d) 8 (2)

(v) The slope of the tangent to the curve $x = \sin \theta$ and

$y = \cos 2\theta$ at $\theta = \frac{\pi}{6}$ is _____.

- (a) $-2\sqrt{3}$ (b) $\frac{-2}{\sqrt{3}}$
 (c) -2 (d) $-\frac{1}{2}$ (2)

(vi) If $\int_{-\frac{\pi}{4}}^{\frac{\pi}{4}} x^3 \cdot \sin^4 x \, dx = k$ then $k =$ _____.

- (a) 1 (b) 2
(c) 4 (d) 0 (2)

(vii) The integrating factor of linear differential equation

$$x \frac{dy}{dx} + 2y = x^2 \log x \text{ is } \underline{\hspace{2cm}}.$$

- (a) x (b) $\frac{1}{x}$
(c) x^2 (d) $\frac{1}{x^2}$ (2)

(viii) If the mean and variance of a binomial distribution are 18 and 12 respectively, then the value of n is _____.

- (a) 36 (b) 54
(c) 18 (d) 27 (2)

Q. 2. Answer the following questions :

[4]

(i) Write the compound statement 'Nagpur is in Maharashtra and Chennai is in Tamilnadu' symbolically. (1)

(ii) If the vectors $2\hat{i} - 3\hat{j} + 4\hat{k}$ and $p\hat{i} + 6\hat{j} - 8\hat{k}$ are collinear, then find the value of p . (1)

(iii) Evaluate : $\int \frac{1}{x^2 + 25} dx$ (1)

(iv) A particle is moving along X-axis. Its acceleration at time t is proportional to its velocity at that time. Find the differential equation of the motion of the particle. (1)

SECTION - B

[16]

Attempt any EIGHT of the following questions :

Q. 3. Construct the truth table for the statement pattern :

$$[(p \rightarrow q) \wedge q] \rightarrow p$$

(2)

Q. 4. Check whether the matrix $\begin{bmatrix} \cos\theta & \sin\theta \\ -\sin\theta & \cos\theta \end{bmatrix}$ is invertible or not. (2)

Q. 5. In ΔABC , if $a = 18$, $b = 24$ and $c = 30$ then find the value of

$$\sin\left(\frac{A}{2}\right).$$

(2)

Q. 6. Find k , if the sum of the slopes of the lines represented by $x^2 + kxy - 3y^2 = 0$ is twice their product. (2)

Q. 7. If $\vec{a}, \vec{b}, \vec{c}$ are the position vectors of the points A, B, C respectively and $5\vec{a} - 3\vec{b} - 2\vec{c} = \vec{0}$, then find the ratio in which the point C divides the line segment BA . (2)

Q. 8. Find the vector equation of the line passing through the point having position vector $4\hat{i} - \hat{j} + 2\hat{k}$ and parallel to the vector $-2\hat{i} - \hat{j} + \hat{k}$. <https://www.maharashtrastudy.com> (2)

Q. 9. Find $\frac{dy}{dx}$, if $y = (\log x)^x$. (2)

Q. 10. Evaluate: $\int \log x \, dx$. (2)

Q. 11. Evaluate: $\int_0^{\frac{\pi}{2}} \cos^2 x \, dx$ (2)

Q. 12. Find the area of the region bounded by the curve $y = x^2$, and the lines $x = 1$, $x = 2$ and $y = 0$. (2)

Q. 13. Solve : $1 + \frac{dy}{dx} = \operatorname{cosec}(x + y)$; put $x + y = u$. (2)

Q. 14. If two coins are tossed simultaneously, write the probability distribution of the number of heads. (2)

SECTION - C

Attempt any EIGHT of the following questions : [24]

Q. 15. Express the following switching circuit in the symbolic form of logic. Construct the switching table :

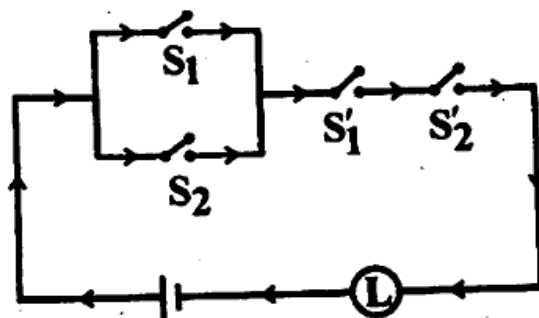

(3)

Q. 16. Prove that : $\tan^{-1}\left(\frac{1}{2}\right) + \tan^{-1}\left(\frac{1}{3}\right) = \frac{\pi}{4}$ (3)

Q. 17. In ΔABC , prove that : $\frac{\cos A}{a} + \frac{\cos B}{b} + \frac{\cos C}{c} = \frac{a^2 + b^2 + c^2}{2abc}$. (3)

Q. 18. Prove by vector method, the angle subtended on a semicircle is a right angle. (3)

Q. 19. Find the shortest distance between the lines $\vec{r} = (4\hat{i} - \hat{j}) + \lambda(\hat{i} + 2\hat{j} - 3\hat{k})$ and $\vec{r} = (\hat{i} - \hat{j} - 2\hat{k}) + \mu(\hat{i} + 4\hat{j} - 5\hat{k})$ (3)

Q. 20. Find the angle between the line $\vec{r} = (\hat{i} + 2\hat{j} + \hat{k}) + \lambda(\hat{i} + \hat{j} + \hat{k})$ and the plane $\vec{r} \cdot (2\hat{i} + \hat{j} + \hat{k}) = 8$. (3)

Q. 21. If $y = \sin^{-1} x$, then show that : $(1 - x^2) \frac{d^2 y}{dx^2} - x \cdot \frac{dy}{dx} = 0$. (3)

Q. 22. Find the approximate value of $\tan^{-1}(1.002)$.

[Given : $\pi = 3.1416$] (3)

Q. 23. Prove that : $\int \frac{1}{a^2 - x^2} dx = \frac{1}{2a} \log \left(\frac{a+x}{a-x} \right) + c$. (3)

Q. 24. Solve the differential equation :

$$x \cdot \frac{dy}{dx} - y + x \cdot \sin \left(\frac{y}{x} \right) = 0. \quad (3)$$

Q. 25. Find k , if

$$f(x) = kx^2(1-x), \text{ for } 0 < x < 1,$$

$$= 0 \quad \text{otherwise}$$

is the p.d.f. of random variable X . (3)

Q. 26. A die is thrown 6 times, if 'getting an odd number' is success,

find the probability of 5 successes. (3)

SECTION - D

Attempt any FIVE of the following questions :

[20]

Q. 27. Solve the following system of equations by the method of reduction : $x + y + z = 6$, $y + 3z = 11$, $x + z = 2y$.

(4)

Q. 28. Prove that the acute angle θ between the lines represented by the

equation $ax^2 + 2hxy + by^2 = 0$ is $\tan \theta = \left| \frac{2\sqrt{h^2 - ab}}{a + b} \right|$.

Hence find the condition that the lines are coincident.

(4)

Q. 29. Find the volume of the parallelepiped whose vertices are $A(3, 2, -1)$, $B(-2, 2, -3)$, $C(3, 5, -2)$ and $D(-2, 5, 4)$.

(4)

Q. 30. Solve the following L.P.P. by graphical method :

Maximize : $z = 10x + 25y$

Subject to : $0 \leq x \leq 3$,

$0 \leq y \leq 3$,

$x + y \leq 5$.

Also find the maximum value of z .

(4)

Q. 31. If $x = f(t)$ and $y = g(t)$ are differentiable functions of t , so that

y is function of x and $\frac{dx}{dt} \neq 0$ then prove that $\frac{dy}{dx} = \frac{\frac{dy}{dt}}{\frac{dx}{dt}}$.

Hence find $\frac{dy}{dx}$, if $x = at^2$, $y = 2at$.

(4)

Q. 32. A box with a square base is to have an open top. The surface area of box is 147 sq.cm. What should be its dimensions in order that the volume is largest? (4)

Q. 33. Evaluate: $\int \frac{5e^x}{(e^x + 1)(e^{2x} + 9)} dx$ (4)

Q. 34. Prove that :

$$\int_0^{2a} f(x) dx = \int_0^a f(x) dx + \int_0^a f(2a - x) dx$$

Hence show that :

$$\int_0^{\pi} \sin x dx = 2 \int_0^{\frac{\pi}{2}} \sin x dx \quad (4)$$

