

JGEEBILS-2024

1. What is the probability that the second child will be a boy for parents whose first child is also a boy?
(a) 0.25
(b) 1
(c) 0.5
(d) 0
2. A flea is about 3mm tall but can jump to a height of about 30 cm. If a child is 36 inches tall had flea-like abilities, how high will she be able to jump?
a. 36 feet
b. 3000 feet
c. 300 feet
d. 360 feet
3. The next number in the series 2, 5, 11, 23, 47, ? will be.
A. 95
B. 96
C. 97
D. 98
4. A batsman scores 100 runs in the 15th inning and thus increases his average by 5. What will be the average after 15th inning?
A. 27
B. 30
C. 32
D. 33
5. The lesion most commonly induced by UV radiation is _____.
A. Chromosome breaks
B. Transition
C. Transversion
D. Thymine dimer
6. If the diameter of a circle is increased by 30% then the area is increased by:
(a) 30%
(b) 60%
(c) 69%

(d) 90%

7. Which of the following is the largest? (1m)

(a) $100^{1/100}$

(b) $100^{1/101}$

(c) $10^{1/51}$

(d) $10^{1/52}$

8. Sum of the eigenvalues of the matrix $\begin{bmatrix} 2 & 2 & -1 \\ 5 & 3 & 1 \\ 1 & 4 & -2 \end{bmatrix}$ is _____. (1m)

(a) 1

(b) 2

(c) 3

(d) None of the above

9. What is the output of the following pseudocode program, which first defines a function functn and then calls it from a for-loop?

```
def functn(n)
    if n==1
        return 1
    else
        return n*functn(n-1)
    endif
enddef

for i = 1 to 5
    print functn(i)
endfor
```

(a) 1 2 3 4 5

(b) 1 1 2 3 5

(c) 1 2 6 24 120

(d) None of the above

10. To estimate the number of fish in a pond, a researcher catches 25 fish randomly, marks them with yellow paint and then puts them back in the pond. The researcher comes back the next day and again catches 25 fish randomly and finds that 5 of them have yellow paint. Estimate the total number of fish in the pond?

a. 25 fish

b. 125 fish

- c. 625 fish
- d. 250 fish

11. In statistics, a distribution is considered symmetric if the mean, median, and mode are equal. If they differ, the distribution is termed asymmetric. If the right tail is longer, we have a positively skewed distribution. Conversely, if the left tail is longer, we have a negatively skewed distribution. For the data: 2,4,6,6, find the skewness?

- (a) Skewness is zero
- (b) Skewness is positive
- (c) Skewness is negative**
- (d) Skewness is +infinity

12. Imagine that you are looking at one cancer cell under the microscope, and trying to estimate the probability that it will die due to a chemotherapy. You know that approximately 95% of cells treated with the chemotherapy turn on the P53 gene and that these cells have 80% chance of dying. The rest 5% that do not turn on P53, have only 10% chance of dying. What is the probability that the cell you're looking at will die?

- a. 76.5%**
- b. 66.5%
- c. 86.5%
- d. None of the above

13. There are two digital clocks in a room. One of them loses 5 minutes each hour, while the other gains 5 minutes each hour. Assuming the two clocks were set at 12:00pm on Tuesday, how much time needs to elapse before the two clocks show exactly the same time again?

- a. 6 days**
- b. 5 days
- c. 4 days
- d. They will never show the same time again

14. Based on the phylogenetic tree provided below, which of the following statements is true?

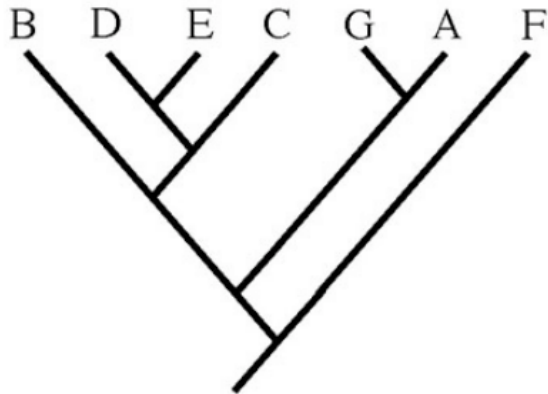

- a. F is more closely related to A than to G
- b. E and D share a common ancestor who is more recent than the ancestor of C and D**
- c. B is more advanced than the others as it is located on the left most branch
- d. All the above are true

15. A train runs at a speed of 90 kmph from P to Q and 110 kmph from Q to P? What is the average speed of the train during the entire journey?

- A. 98.0 kmph
- B. 99.0 kmph**
- C. 100 kmph
- D. 101 kmph

16. Four charges of magnitude q are put on a square of side length a . If three of the charges are positive and one is negative, what is the magnitude of the electric field at the centre?

The magnitude of the electric field at a distance r is $E = q/4\pi\epsilon_0 a^2$.

- a. $2q/\pi\epsilon_0 a^2$
- b. $q/\pi\epsilon_0 a^2$**
- c. $q/2\pi\epsilon_0 a^2$
- d. 0

17. The volume of a liquid is measured to be 100 ml with an uncertainty of ± 3 ml, and its mass is measured to be 100 g with an uncertainty of ± 4 g. By calculating mass over volume, the density is reported to be 1 g/ml. Assuming the errors are uncorrelated, what is the uncertainty in the reported density, measured in g/ml?

- a. 1/100

- b. 5/100
- c. 7/100**
- d. 10/100

18. Shape A can be mapped onto shape B by

[Figure needed]

- a. translation and rotation
- b. rotation and scale transformation
- c. reflection and scale transformation
- d. reflection, scale transformation and translation**

19. The specific gravity of an alloy made of two metals in equal volumes is 4. But when the alloy is made up of the same two metals in equal masses, its specific gravity is 3. The specific gravity of each metal is? The specific gravity is defined as the density of the material compared to some reference density.

- a. 8, 4
- b. 6, 4
- c. 6, 2**
- d. 4, 2

20. Fraunhofer lines are dark lines in the solar spectrum. They arise because

- a. the sun consists mainly of hydrogen and helium, which do not emit a continuous spectrum.
- b. the sun's outer regions contain other elements which emit various wavelengths, making the spectrum uneven.
- c. gases in the sun's outer region absorb specific wavelengths.**
- d. the absorption of specific wavelengths by gasses in the Earth's atmosphere.

21. The elephant-nosed weakly electric fish generate electric fields to locate and identify nearby objects. They detect distortion of their own electric organ discharge to identify nearby objects. Consider the two following statements:

- i. An object is detectable if its specific resistance is different from that of water
- ii. An object is detectable if its specific capacitance is different from that of water

- a. **Both statements i and ii are true.**
- b. Only statement i is true.
- c. Only statement ii is true.
- d. Neither statement i nor statement ii are true.

22. A thin cylindrical rod is rotating on a horizontal plane about its center of mass, which is at rest. It breaks instantaneously into two cylindrical halves. The two resulting pieces

- a. Move apart without spinning.
- b. Spin but have their centres of mass at rest.
- c. **Move apart and spin in the same direction as the original rod.**
- d. Move apart and spin in opposite directions.

23. I measure a certain quantity and report the results in units of Newtons x metres. The quantity is

- a. a measure of work.
- b. a measure of torque.
- c. a measure of force.
- d. **not clear from the given information.**

24. An ideal gas at pressure P_0 , volume V_0 and temperature T_0 is allowed to isothermally expand to twice its initial volume. What is the final pressure?

- A) $P_0/2$**
- B) $2 P_0$
- C) P_0
- D) Undetermined

25. In quantum mechanics, the simple harmonic oscillator has a non-zero rest energy. This is best understood as:

- a. A measurement convention, since the zero point of energy is arbitrary.
- b. The result of thermal fluctuations.
- c. **The result of the uncertainty principle.**
- d. An error due to our inability to measure small quantities.

26. Imagine the gas that forms the thin atmosphere of a small exoplanet at a constant temperature. The speed of gas molecules at equilibrium are described by the Maxwell-Boltzmann distribution. Molecules whose speed exceeds the escape velocity will occasionally be lost to space. Once the system re-equilibrates at the same temperature, which of the following statements is correct about the distribution of speeds:

- a. It will be identical to the original distribution, but truncated beyond the escape velocity.
- b. **It will be identical to the original distribution.**
- c. It will be a new Maxwell-Boltzmann distribution with a lower average velocity than before.
- d. It will be a new Maxwell-Boltzmann distribution with a higher average velocity than before.

27. A particle moves under the potential $U(x) = e^{-x^2} + 0.01x^2$.

Which of the following describes the equilibrium points in the region $-\infty < x < \infty$

- a. One stable point, no unstable points
- b. One unstable points, no stable points
- c. **Two stable points, one unstable point**
- d. Two unstable points, one stable point

28. A cricket ball and a table tennis ball are dropped with zero initial vertical velocity. Each will eventually reach a different terminal velocity in air. Which of the following is true? (We can say the ball "reaches" its terminal velocity when it hits 99% of the expected value.)

- a. **The cricket ball has a higher terminal velocity and will reach it later.**
- b. The table tennis ball has a higher terminal velocity and will reach it later.
- c. The cricket ball has a higher terminal velocity and will reach it sooner.

- d. The table tennis ball has a higher terminal velocity and will reach it sooner.

29. Assume that the Earth is in a circular orbit around the sun. If the mass of the sun is suddenly reduced to half of its original value, what will happen to the Earth?

- a. It will settle into a smaller orbit.
 b. It will remain in the same orbit.
 c. It will settle into a larger orbit.
 d. **It will escape from the sun.**

30.

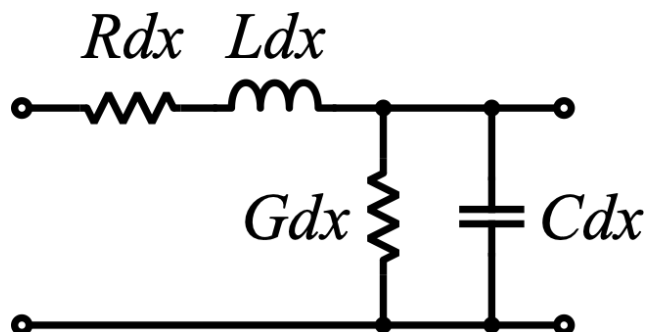

Suppose a two-wire transmission line has a basic element as represented above. Assume the special case of a lossless line where $R = 0$ and $G = 0$.

Which of the following equations describes this system:

- a. $\frac{\partial V}{\partial t} = -\frac{1}{c} \frac{\partial I}{\partial x'}$, $\frac{\partial I}{\partial t} = -\frac{1}{L} \frac{\partial V}{\partial x}$
 b. $\frac{\partial V}{\partial t} = -C \frac{\partial I}{\partial x'}$, $\frac{\partial I}{\partial t} = -\frac{1}{L} \frac{\partial V}{\partial x}$
 c. $\frac{\partial V}{\partial t} = -\frac{1}{c} \frac{\partial I}{\partial x'}$, $\frac{\partial I}{\partial t} = -L \frac{\partial V}{\partial x}$
 d. $\frac{\partial V}{\partial t} = -C \frac{\partial I}{\partial x'}$, $\frac{\partial I}{\partial t} = -L \frac{\partial V}{\partial x}$

31. Which of the following is an aromatic compound?

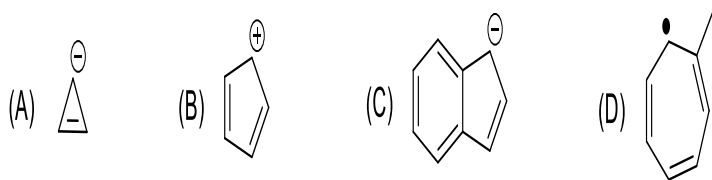

Answer: C

32. Which among the following is the easiest method to estimate the concentration of glycerol in an aqueous solution of glycerol?

- A. UV absorption spectroscopy
- B. Gas chromatography
- C. pH measurement
- D. Viscosity measurement**

33. Electric potential is a _____ quantity

- A. Vector
- B. Scalar**
- C. Tensor
- D. Pseudo Vector

34. In a complexometric titration



The end point is estimated spectrophotometrically. If S and P have $\epsilon = 0$, the shape of the titration curve is which of the following?

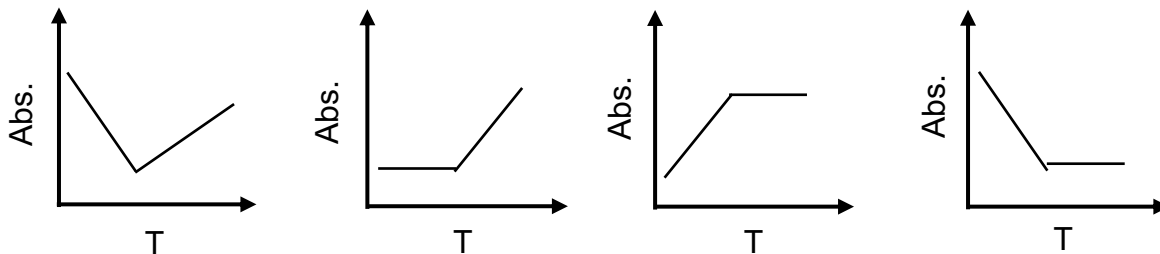

35. A wild type protein and its mutants E107A and E107D were analysed using isoelectric focussing, Which of the following options are most likely to correspond to lanes A and B in the figure below?

- A. A – Wild type; B – E107A mutant**
- B. A - E107A mutant; B – WT
- C. A - wild type; B – E107D mutant
- D. A - E107A mutant; B – E107D mutant

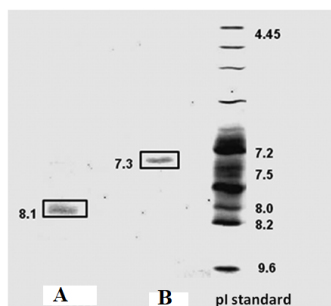

36. The pKa of the amino group of a zwitterion is 9.6. In a 0.1 M solution of the zwitterion at pH=9.0, what percentage of the amino group of the zwitterion is protonated?

- A. 80%
- B. 60%
- C. 40%
- D. 20%

37. Which of the following equations represents an oxidation-reduction reaction?

- A. $\text{Ba}(\text{NO}_3)_2 + \text{Na}_2\text{SO}_4 \rightarrow \text{BaSO}_4 + 2\text{NaNO}_3$
- B. $\text{H}_3\text{PO}_4 + 3\text{KOH} \rightarrow \text{K}_3\text{PO}_4 + 3\text{H}_2\text{O}$
- C. $\text{Fe}(\text{s}) + \text{S}(\text{s}) \rightarrow \text{FeS}(\text{s})$
- D. $\text{NH}_3(\text{g}) + \text{HCl}(\text{g}) \rightarrow \text{NH}_4\text{Cl}(\text{s})$

38. Secondary alcohols on catalytic dehydrogenation by Cu-Ni couple give;

- a) Ketone
- b) Aldehyde
- c) Carboxylic acid
- d) Amine

39. The following pair of compounds is an example of

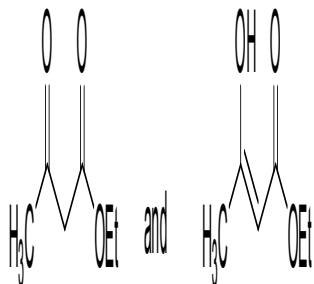

A. Positional Isomers **B. Functional Isomers** C. Stereo Isomers D. None

40. Which number of signals are observed for the following compound in ^{13}C -NMR proton decoupled spectrum?

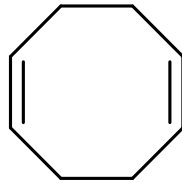

A. One **B. Two** C. Eight D. Four

41. The spine of a neuron is approximately a sphere of diameter $1\mu\text{m}$. The concentration of K^+ within this spine is 150mM . How many K^+ ions are in this sphere? Assume Avagadro's number is 6.023×10^{23} . Choose the option closest to the correct answer.

- a. 5×10^{10}
- b. 5×10^7**
- c. 5×10^5
- d. 5×10^{12}

42. Arrange the metabolites in increasing order of phosphoryl transfer potential
p) ATP, q) Phosphoenolpyruvate, r) 1,3-Bisphosphoglycerate, s) pyrophosphate

- a) $s < q < r < p$
- b) $q < r < s < p$
- c) $s < p < r < q$**
- d) $p < s < r < q$

43. An enzyme has a V_{max} of $50 \mu\text{mol product formed (minute X mg protein)}^{-1}$ and a K_m of $10 \mu\text{M}$ for the substrate. When a reaction mixture contains the enzyme and $5 \mu\text{M}$ substrate, which of the following percentage of the maximum velocity will be closest to the initial reaction rate?

- a. 5%
- b. 15%
- c. 33%**
- d. 50%

44. The keto (left) and enol (right) tautomerized structures of guanine is shown below.

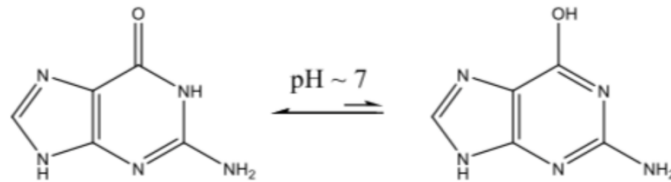

The keto and enol forms of cytosine and thymine are shown below.

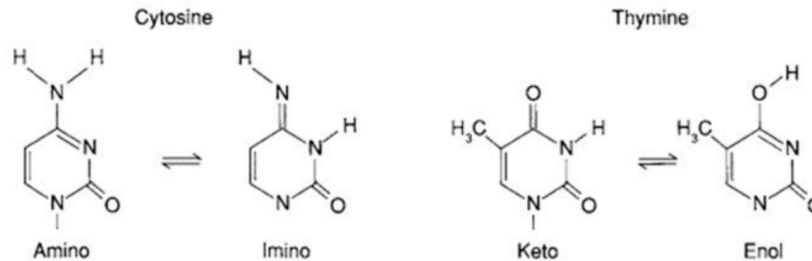

Which of the following bases will the **enol form** of guanine **most stably** base pair with

- A. Amino form of cytosine
- B. Imino form of cytosine
- C. Keto form of Thymine
- D. Enol form of Thymine

45. If the backbone -NH_2 group in amino acids are modified to $\text{-NH(CH}_3\text{)}$ group, how will the allowed regions in Ramachandran map of the modified protein change?

- A. Allowed region remain unchanged.
- B. Allowed regions shrink.
- C. Allowed regions expand.
- D. It depends on the specific amino acid side chains.

46. The time required for replication of the E.coli chromosome is 40 minutes but the bacterium is capable of dividing every 20 minutes under the right nutritional conditions. This is because DNA replication can initiate in the daughter chromosomes before the initial replication is completed. How many replication bubbles would be observed if DNA replication initiates one additional time over a single cell division cycle?

- a. 2
- b. 4
- c. 3
- d. 5

47. A friend of yours measured the quantity of DNA in grasshopper cells growing in the cell culture. Cells examined during the G2 phase of the cell cycle contained 200 units of DNA/cell. What would be the amount of DNA/cell in grasshopper cells seen in the anaphase of mitosis?

- A. 50 units
- B. 100 units
- C. 400 units
- D. 200 units**

48. A woman is heterozygous for both phenylketonuria mutation and for X-linked hemophilia mutation. She has a child with a phenotypically normal man, who is also heterozygous for a phenylketonuria mutation. What is the probability that the child will be affected by both the diseases?

- A. 1/8
- B. 1/4
- C. 1/16**
- D. 3/8

49. Carbon dioxide in the blood is mostly _____.

- A. bound to albumin
- B. bound to hemoglobin
- C. in the form of carbonic acid**
- D. bound to myoglobin

50. Species S1 and S2 use the same resource R, with S1 being more efficient in using the resource. A predator P consumes both prey species, but at different rates. Which statement is CORRECT?

- a. P will always eat S2, because it is an inferior competitor to S1
- b. S1 will outcompete S2, unless the predator eats more of S1**
- c. P has no impact on the outcome of competition between S1 and S2
- d. P will always preferentially consume S1 because it will be more abundant

51. After fertilization, cells in vertebrate embryos divide at regular intervals giving rise to a mass of cells termed the blastula. As cells divide, they undergo cleavage, where the enormous volume of the egg cytoplasm is slowly divided into numerous small cells, such that the total volume of the embryo remains the same. How embryo maintains its overall volume during this process?

- a) Cells in early vertebrate embryos do not have G1 and G2 phases and hence do not increase in volume.**
- b) Cells in early vertebrate embryos do not have the S phase and hence do not increase in volume.
- c) Cells have all cell cycle phases, but they halve protein production in every cell cycle.
- d) Cells normally increase in volume as any dividing cell but degrade the half the material to ensure embryo volume is maintained.

52. Many biological processes are known to oscillate over time, which are represented by an increase in a molecular factor followed by a decrease, which continues over time. Which of the following mechanisms would lead to multiple cycles of oscillating protein amounts in a cell over time?
- a) A constant activator of protein production that is regulated by a positive feedback loop.
 - b) A constant activator of protein production that is regulated by a negative feedback loop.**
 - c) A one-time activator of protein production that is regulated by a negative feedback loop.
 - d) A one-time activator of protein production that is regulated by a positive feedback loop.

53. In the euarchaeotic bacterium *Pyrococcus furiosus* the glycolysis pathway is modified by the use of ADP dependent glucokinase and ADP dependent phosphofructokinase. What will be the net gain of ATP during glycolysis in *P. furiosus*?

- A. 2
- B. 3
- C. 4**
- D. 6

54. Bananas we routinely eat are seedless because

- A) They are naturally parthenogenetic
- B) They are triploid**
- C) They are haploid
- D) Their fruits develop faster than the seeds

55. At the Hogwarts School of Wizardry they use the fairly modern science of genetics to identify potential witches and wizards. Being a witch or a wizard is dependent on the presence of an autosomal dominant trait (the W allele). The W allele can be suppressed by the squib allele (s), an unlinked autosomal recessive trait. Presence of two s alleles can lead to no magical powers in individuals with the W allele. Given these observations what fraction of the progeny from the cross outlined below will be capable of performing magic and candidates for the Hogwarts School of Wizardry?

ww:ss x Ww:Ss

- a. 1/4**
- b. 1/8
- c. 1/2
- d. 0

56. Assume a gene does not have any introns, any upstream promoter or regulatory element, or any element post the DNA sequence ending at the STOP position. If a hypothetical genome has only 500 genes – and each gene encodes an mRNA for a 50 kDa protein. What would be the approximate size of this genome?

- A) 275 kb
- B) 250 kb
- C) 500 kb

D) 750 kb

57. *Orobanche* is an obligate parasitic plant. Despite being a plant, it is not an autotroph. It is related to an autotrophic plant *Mimulus* and an autotrophic partial parasite *Triphysaria* as shown in the following rooted tree. Which of the following statements is most likely to be true about the evolution of *Orobanche*? Assume maximum parsimony.

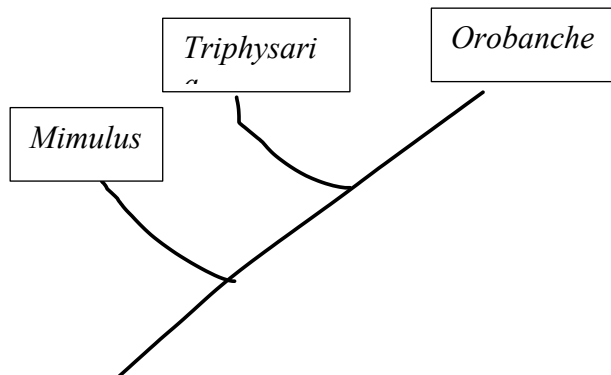

- (a) The ancestor lacked photosynthetic apparatus, which was gained independently and exclusively in the *Mimulus* and *Triphysaria* lineages
- (b) Photosynthetic machinery was present in all the ancestral nodes, but lost specifically in the terminal branch leading to *Orobanche***
- (c) Photosynthesis was lost following the branching of *Mimulus*, but regained in the terminal branch to *Triphysaria*.
- (d) Rooted trees cannot be used to make predictions about ancestral states under the maximum parsimony assumption.

58. One molecule of a small Ras-like GTPase (Ras) of 22 kDa forms a strong high affinity complex with one molecule of the GTPase activating protein (GAP) of 50 kDa. The complex was analysed using size exclusion chromatography and the profile is shown below. The peaks 1, 2, 3 labeled in the profile were analysed on an SDS-PAGE gel. How many bands do you expect to see in the SDS-PAGE profile for the three lanes corresponding to peaks 1, 2 and 3 under reducing condition?

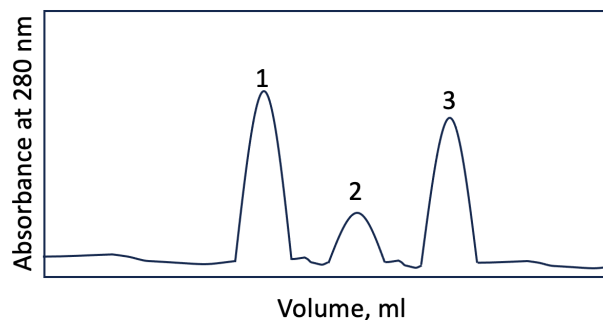

- A. Peak 1 – 3 bands at 72, 50 and 22 kDa; Peak 2 – 1 band at 50 kDa; Peak 3 – 1 band at 22 kDa
- B. Peak 1 – 1 band at 22 kDa; Peak 2 – 1 band at 50 kDa; Peak 3 – 3 bands at 72, 50 and 22 kDa
- C. Peak 1 – 1 band at 22 kDa; Peak 2 – 1 band at 50 kDa; Peak 3 – 2 bands at 50 and 22 kDa
- D. Peak 1 – 2 bands at 50 and 22 kDa; Peak 2 – 1 band at 50 kDa; Peak 3 – 1 band at 22 kDa**

59. You restriction map a vector using *Bam* HI, *Eco* RI and *Hae* III and obtained fragments of the following sizes. Draw a restriction map of the vector and determine which of the following statements is correct.

Results:

Bam HI alone: 4,000bp;

Eco RI alone: 4,000bp;

Hae III alone: 3,000bp and 1,000bp;

Bam HI and *Eco* RI: 3,500bp, 500bp;

Bam HI and *Hae* III: 2,300bp, 1,000bp, 700bp;

Eco RI and *Hae* III: 2,800bp, 1,000bp, 200bp;

Bam HI, *Eco* RI, and *Hae* III: 2,300bp, 1,000bp, 500bp, 200bp

Answer

- a. There are three *Hae* III sites in this vector
- b. *Bam* HI is 1,000bp away from *Eco* RI
- c. *Bam* HI is present within the smaller fragment from the *Hae* III digestion
- d. *Eco* RI is present within the larger fragment from the *Hae* III digestion**

60. A predatory fish blows bubbles just before it approaches and stuns its prey. A student postulated that blowing bubbles is a socially learned behavior and is a not heritable trait. To test this hypothesis, she raised the offsprings of the wildtype fishes either in “treatment 1”: the fishes were raised in a tank with the parent population or “treatment 2”: they were raised in a tank in isolation without any conspecifics. If blowing bubbles is not a socially learnt behavior, we would expect:

- a) None of the fishes in treatment 1 and 2 will blow bubbles
- b) Individuals in both treatment 1 and 2 will blow bubbles**
- c) 75% fishes in treatment 1 will blow bubbles but none in treatment 2
- d) 75% fishes in treatment 2 will blow bubbles but none in treatment 1

