

FINAL JEE–MAIN EXAMINATION – JANUARY, 2024

(Held On Wednesday 31st January, 2024)

TIME : 3 : 00 PM to 6 : 00 PM

SECTION-A

31. A light string passing over a smooth light fixed pulley connects two blocks of masses m_1 and m_2 . If the acceleration of the system is $g/8$, then the ratio of masses is

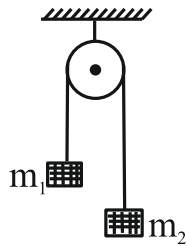

- (1) $\frac{9}{7}$ (2) $\frac{8}{1}$
 (3) $\frac{4}{3}$ (4) $\frac{5}{3}$

Ans. (1)

Sol. $a = \frac{(m_1 - m_2)g}{8} = \frac{g}{8}$

$$8m_1 - 8m_2 = m_1 + m_2$$

$$7m_1 = 9m_2$$

$$\frac{m_1}{m_2} = \frac{9}{7}$$

32. A uniform magnetic field of $2 \times 10^{-3} \text{ T}$ acts along positive Y-direction. A rectangular loop of sides 20 cm and 10 cm with current of 5 A is Y-Z plane. The current is in anticlockwise sense with reference to negative X axis. Magnitude and direction of the torque is :
- (1) $2 \times 10^{-4} \text{ N-m}$ along positive Z-direction
 (2) $2 \times 10^{-4} \text{ N-m}$ along negative Z-direction
 (3) $2 \times 10^{-4} \text{ N-m}$ along positive X-direction
 (4) $2 \times 10^{-4} \text{ N-m}$ along positive Y-direction

Ans. (2)

Sol.

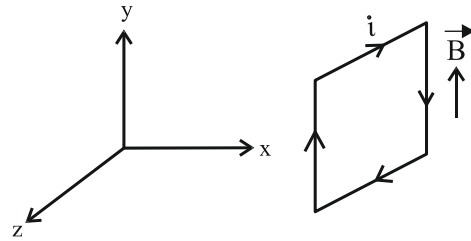

$$\begin{aligned} \vec{M} &= i\vec{A} \\ &= 5 \times (0.2) \times (0.1) (-\hat{i}) \\ &= 0.1 (-\hat{i}) \\ \vec{\tau} &= \vec{M} \times \vec{B} = 0.1 (-\hat{i}) \times (2 \times 10^{-3}) (\hat{j}) \\ &= 2 \times 10^{-4} (-\hat{k}) \text{ N-m} \end{aligned}$$

33. The measured value of the length of a simple pendulum is 20 cm with 2 mm accuracy. The time for 50 oscillations was measured to be 40 seconds with 1 second resolution. From these measurements, the accuracy in the measurement of acceleration due to gravity is N%. The value of N is:

- (1) 4 (2) 8
 (3) 6 (4) 5

Ans. (3)

Sol. $T = 2\pi \sqrt{\frac{\ell}{g}}$

$$g = \frac{4\pi^2 \ell}{T^2}$$

$$\frac{\Delta g}{g} = \frac{\Delta \ell}{\ell} + \frac{2\Delta T}{T}$$

$$= \frac{0.2}{20} + 2 \left(\frac{1}{40} \right)$$

$$= \frac{0.3}{20}$$

$$\text{Percentage change} = \frac{0.3}{20} \times 100 = 6\%$$

34. Force between two point charges q_1 and q_2 placed in vacuum at 'r' cm apart is F. Force between them when placed in a medium having dielectric $K = 5$ at 'r/5' cm apart will be:

- (1) $F/25$ (2) $5F$
 (3) $F/5$ (4) $25F$

Ans. (2)

Sol. In air $F = \frac{1}{4\pi\epsilon_0} \frac{q_1q_2}{r^2}$

In medium

$$F' = \frac{1}{4\pi(K\epsilon_0)} \frac{q_1q_2}{(r/5)^2} = \frac{25}{4\pi(5\epsilon_0)} \frac{q_1q_2}{(r)^2} = 5F$$

35. An AC voltage $V = 20\sin 200\pi t$ is applied to a series LCR circuit which drives a current

$$I = 10\sin\left(200\pi t + \frac{\pi}{3}\right).$$

The average power dissipated is:

- (1) 21.6 W (2) 200 W
 (3) 173.2 W (4) 50 W

Ans. (4)

Sol. $\langle P \rangle = IV \cos \phi$

$$= \frac{20}{\sqrt{2}} \times \frac{10}{\sqrt{2}} \times \cos 60^\circ$$

$$= 50 \text{ W}$$

36. When unpolarized light is incident at an angle of 60° on a transparent medium from air. The reflected ray is completely polarized. The angle of refraction in the medium is

- (1) 30° (2) 60°
 (3) 90° (4) 45°

Ans. (1)

Sol. By Brewster's law

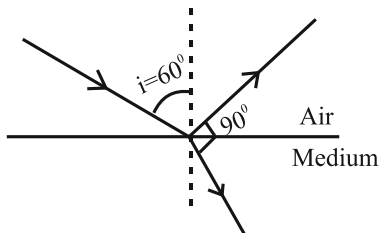

At complete reflection refracted ray and reflected ray are perpendicular.

37. The speed of sound in oxygen at S.T.P. will be approximately:

(Given, $R = 8.3 \text{ JK}^{-1}, \gamma = 1.4$)

- (1) 310 m/s
 (2) 333 m/s
 (3) 341 m/s
 (4) 325 m/s

Ans. (1)

Sol. $v = \sqrt{\frac{\gamma RT}{M}} = \sqrt{\frac{1.4 \times 8.3 \times 273}{32 \times 10^{-3}}}$
 $= 314.8541 \approx 315 \text{ m/s}$

38. A gas mixture consists of 8 moles of argon and 6 moles of oxygen at temperature T. Neglecting all vibrational modes, the total internal energy of the system is

- (1) 29 RT
 (2) 20 RT
 (3) 27 RT
 (4) 21 RT

Ans. (3)

Sol. $U = nC_V T$

$$\Rightarrow U = n_1 C_{V1} T + n_2 C_{V2} T$$

$$\Rightarrow 8 \times \frac{3R}{2} \times T + 6 \times \frac{5R}{2} \times T$$

$$= 27RT$$

39. The resistance per centimeter of a meter bridge wire is r, with $X \Omega$ resistance in left gap. Balancing length from left end is at 40 cm with 25 Ω resistance in right gap. Now the wire is replaced by another wire of 2r resistance per centimeter. The new balancing length for same settings will be at

- (1) 20 cm
 (2) 10 cm
 (3) 80 cm
 (4) 40 cm

Ans. (4)

Sol.

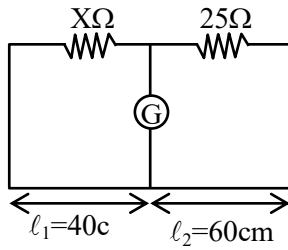

$$\frac{25}{rl_1} = \frac{X}{rl_2} \quad \dots(i)$$

$$\frac{25}{2rl_1} = \frac{X}{2rl_2} \quad \dots(ii)$$

From (i) and (ii)

$$l_2 = l_1 = 40 \text{ cm}$$

40. Given below are two statements:

Statement I: Electromagnetic waves carry energy as they travel through space and this energy is equally shared by the electric and magnetic fields.

Statement II: When electromagnetic waves strike a surface, a pressure is exerted on the surface.

In the light of the above statements, choose the most appropriate answer from the options given below:

- (1) Statement I is incorrect but Statement II is correct
- (2) Both Statement I and Statement II are correct.
- (3) Both Statement I and Statement II are incorrect.
- (4) Statement I is correct but Statement II is incorrect.

Ans. (2)

$$\text{Sol. } \frac{-\epsilon_0 E^2}{2} = \frac{1}{2\mu_0}$$

$$\therefore E = CB \text{ and } C = \frac{1}{\mu_0 \epsilon_0}$$

41. In a photoelectric effect experiment a light of frequency 1.5 times the threshold frequency is made to fall on the surface of photosensitive material. Now if the frequency is halved and intensity is doubled, the number of photo electrons emitted will be:

- (1) Doubled
- (2) Quadrupled
- (3) Zero
- (4) Halved

Ans. (3)

Sol. Since $\frac{f}{2} < f_0$ i.e. the incident frequency is less than threshold frequency. Hence there will be no emission of photoelectrons.
 \Rightarrow current = 0

42. A block of mass 5 kg is placed on a rough inclined surface as shown in the figure.

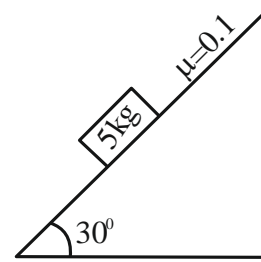

If \vec{F}_1 is the force required to just move the block up the inclined plane and \vec{F}_2 is the force required to just prevent the block from sliding down, then the value of $|\vec{F}_1| - |\vec{F}_2|$ is : [Use $g = 10 \text{ m/s}^2$]

- (1) $25\sqrt{3} \text{ N}$
- (2) $50\sqrt{3} \text{ N}$
- (3) $\frac{5\sqrt{3}}{2} \text{ N}$
- (4) 10 N

Ans. ($5\sqrt{3} \text{ N}$) BONUS

Sol. $f_k = \mu mg \cos \theta$

$$= 0.1 \times \frac{50 \times \sqrt{3}}{2}$$

$$= 2.5\sqrt{3} \text{ N}$$

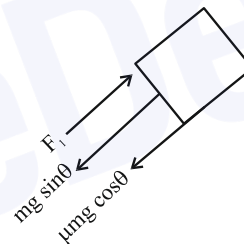

$$F_1 = mg \sin \theta + f_k$$

$$= 25 + 2.5\sqrt{3}$$

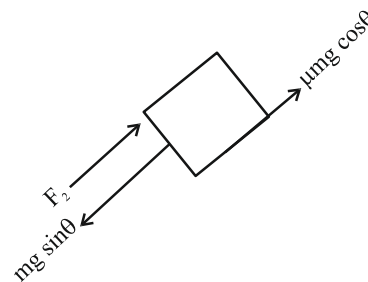

$$F_2 = mg \sin \theta - f_k$$

$$= 25 - 2.5\sqrt{3}$$

$$\therefore F_1 - F_2 = 5\sqrt{3} \text{ N}$$

43. By what percentage will the illumination of the lamp decrease if the current drops by 20%?

- (1) 46% (2) 26%
(3) 36% (4) 56%

Ans. (3)

Sol. $P = i^2 R$

$$P_{\text{int}} = I_{\text{int}}^2 R$$

$$P_{\text{final}} = (0.8 I_{\text{int}})^2 R$$

% change in power =

$$\frac{P_{\text{final}} - P_{\text{int}}}{P_{\text{int}}} \times 100 = (0.64 - 1) \times 100 = -36\%$$

44. If two vectors \vec{A} and \vec{B} having equal magnitude R are inclined at an angle θ , then

$$(1) |\vec{A} - \vec{B}| = \sqrt{2} R \sin\left(\frac{\theta}{2}\right)$$

$$(2) |\vec{A} + \vec{B}| = 2 R \sin\left(\frac{\theta}{2}\right)$$

$$(3) |\vec{A} + \vec{B}| = 2 R \cos\left(\frac{\theta}{2}\right)$$

$$(4) |\vec{A} - \vec{B}| = 2 R \cos\left(\frac{\theta}{2}\right)$$

Ans. (3)

Sol. The magnitude of resultant vector

$$R' = \sqrt{a^2 + b^2 + 2ab \cos \theta}$$

Here $a = b = R$

$$\text{Then } R' = \sqrt{R^2 + R^2 + 2R^2 \cos \theta}$$

$$= R\sqrt{2} \sqrt{1 + \cos \theta}$$

$$= \sqrt{2} R \sqrt{2 \cos^2 \frac{\theta}{2}}$$

$$= 2R \cos \frac{\theta}{2}$$

45. The mass number of nucleus having radius equal to half of the radius of nucleus with mass number 192 is:

- (1) 24 (2) 32
(3) 40 (4) 20

Ans. (1)

Sol. $R_1 = \frac{R_2}{2}$

$$R_0 (A_1)^{1/3} = \frac{R_0}{2} (A_2)^{1/3}$$

$$A_1 = \frac{1}{8} A_2$$

$$A_1 = \frac{192}{8} = 24$$

46. The mass of the moon is 1/144 times the mass of a planet and its diameter 1/16 times the diameter of a planet. If the escape velocity on the planet is v , the escape velocity on the moon will be:

- (1) $\frac{v}{3}$ (2) $\frac{v}{4}$
(3) $\frac{v}{12}$ (4) $\frac{v}{6}$

Ans. (1)

Sol. $V_{\text{escape}} = \sqrt{\frac{2GM}{R}}$

$$V_{\text{planet}} = \sqrt{\frac{2GM}{R}} = v$$

$$V_{\text{Moon}} = \sqrt{\frac{2GM \times 16}{144 R}} = \frac{1}{3} \sqrt{\frac{2GM}{R}}$$

$$V_{\text{Moon}} = \frac{V_{\text{Planet}}}{3} = \frac{v}{3}$$

47. A small spherical ball of radius r , falling through a viscous medium of negligible density has terminal velocity ' v '. Another ball of the same mass but of radius $2r$, falling through the same viscous medium will have terminal velocity:

- (1) $\frac{v}{2}$ (2) $\frac{v}{4}$
(3) $4v$ (4) $2v$

Ans. (1)

Sol. Since density is negligible hence Buoyancy force will be negligible

At terminal velocity.

$$Mg = 6\pi\eta r v$$

$$V \propto \frac{1}{r} \quad (\text{as mass is constant})$$

$$\text{Now, } \frac{v}{v'} = \frac{r'}{r}$$

$$r' = 2r$$

$$\text{So, } v' = \frac{v}{2}$$

48. A body of mass 2 kg begins to move under the action of a time dependent force given by $\vec{F} = (6t \hat{i} + 6t^2 \hat{j})\text{N}$. The power developed by the force at the time t is given by:

- (1) $(6t^4 + 9t^5)\text{W}$
- (2) $(3t^3 + 6t^5)\text{W}$
- (3) $(9t^5 + 6t^3)\text{W}$
- (4) $(9t^3 + 6t^5)\text{W}$

Ans. (4)

Sol. $\vec{F} = (6t \hat{i} + 6t^2 \hat{j})\text{N}$

$$\vec{F} = m\vec{a} = (6t\hat{i} + 6t^2\hat{j})$$

$$\vec{a} = \frac{\vec{F}}{m} = (3t\hat{i} + 3t^2\hat{j})$$

$$\vec{v} = \int_0^t \vec{a} dt = \frac{3t^2}{2} \hat{i} + t^3 \hat{j}$$

$$P = \vec{F} \cdot \vec{v} = (9t^3 + 6t^5)\text{W}$$

49.

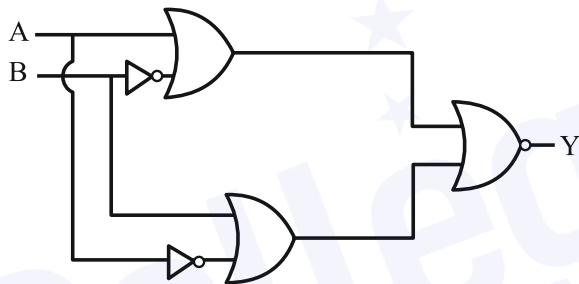

The output of the given circuit diagram is

| A | B | Y |
|---|---|---|
| 0 | 0 | 0 |
| 1 | 0 | 0 |
| 0 | 1 | 0 |
| 1 | 1 | 1 |

| A | B | Y |
|---|---|---|
| 0 | 0 | 0 |
| 1 | 0 | 1 |
| 0 | 1 | 1 |
| 1 | 1 | 0 |

| A | B | Y |
|---|---|---|
| 0 | 0 | 0 |
| 1 | 0 | 0 |
| 0 | 1 | 0 |
| 1 | 1 | 0 |

| A | B | Y |
|---|---|---|
| 0 | 0 | 0 |
| 1 | 0 | 0 |
| 0 | 1 | 1 |
| 1 | 1 | 0 |

Ans. (3)

Sol.

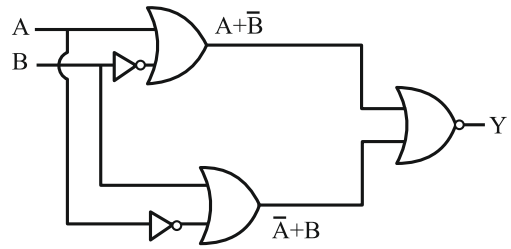

$$\text{If } A = 0; \bar{A} = 1$$

$$A = 1; \bar{A} = 0$$

$$B = 0; \bar{B} = 1$$

$$B = 1; \bar{B} = 0$$

$$Y = (A + \bar{B}) + (\bar{A} + B) = (1 + 1) = 0$$

50. Consider two physical quantities A and B related to each other as $E = \frac{B - x^2}{At}$ where E, x and t have

dimensions of energy, length and time respectively. The dimension of AB is

(1) $L^{-2}M^1T^0$
 (2) $L^2M^{-1}T^1$
 (3) $L^{-2}M^{-1}T^1$
 (4) $L^0M^{-1}T^1$

Ans. (2)

Sol. $[B] = L^2$

$$A = \frac{x^2}{tE} = \frac{L^2}{TML^2T^{-2}} = \frac{1}{MT^{-1}}$$

$$[A] = M^{-1}T$$

$$[AB] = [L^2M^{-1}T^1]$$

SECTION-B

51. In the following circuit, the battery has an emf of 2 V and an internal resistance of $\frac{2}{3} \Omega$. The power consumption in the entire circuit is _____ W.

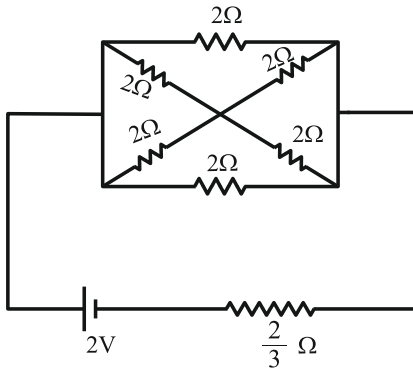

Ans. (3)

Sol. $R_{eq} = \frac{4}{3} \Omega$
 $\therefore P = \frac{V^2}{R_{eq}} = \frac{4}{4/3} = 3 \text{ W}$

52. Light from a point source in air falls on a convex curved surface of radius 20 cm and refractive index 1.5. If the source is located at 100 cm from the convex surface, the image will be formed at _____ cm from the object.

Ans. (200)

Sol.

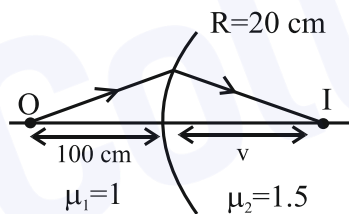

$$\frac{\mu_2}{v} - \frac{\mu_1}{u} = \frac{\mu_2 - \mu_1}{R}$$

$$\frac{1.5}{v} - \frac{1}{-100} = \frac{1.5 - 1}{20}$$

cm

Distance from object
 = 100+100
 = 200 cm

53. The magnetic flux ϕ (in weber) linked with a closed circuit of resistance 8Ω varies with time (in seconds) as $\phi = 5t^2 - 36t + 1$. The induced current in the circuit at $t = 2\text{ s}$ is _____ A.

Ans. (2)

Sol. $\epsilon = -\left(\frac{d\phi}{dt}\right) = 10t - 36$
 at $t = 2, \epsilon = 16 \text{ V}$
 $i = \frac{\epsilon}{R} = \frac{16}{8} = 2 \text{ A}$

54. Two blocks of mass 2 kg and 4 kg are connected by a metal wire going over a smooth pulley as shown in figure. The radius of wire is $4.0 \times 10^{-5} \text{ m}$ and Young's modulus of the metal is $2.0 \times 10^{11} \text{ N/m}^2$. The longitudinal strain developed in the wire is $\frac{1}{\alpha\pi}$. The value of α is _____. [Use $g = 10 \text{ m/s}^2$]

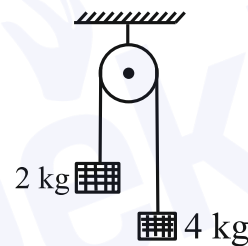

Ans. (12)

Sol. $T = \left(\frac{2m_1 m_2}{m_1 + m_2}\right) g = \frac{80}{3} \text{ N}$
 $A = \pi r^2 = 16\pi \times 10^{-10} \text{ m}^2$
 Strain = $\frac{\Delta l}{l} = \frac{F}{AY} = \frac{T}{AY}$
 $= \frac{80/3}{16\pi \times 10^{-10} \times 2 \times 10^{11}} = \frac{1}{12\pi}$
 $\alpha = 12$

55. A body of mass 'm' is projected with a speed 'u' making an angle of 45° with the ground. The angular momentum of the body about the point of projection, at the highest point is expressed as $\frac{\sqrt{2} \mu u^3}{Xg}$. The value of 'X' is _____.

Ans. (8)

Sol.

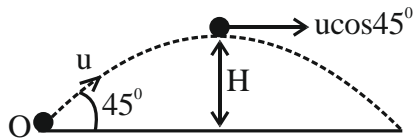

$$L = mu \cos \theta \frac{u^2 \sin^2 \theta}{2g}$$

$$= mu^3 \frac{1}{4\sqrt{2}g} \Rightarrow x = 8$$

56. Two circular coils P and Q of 100 turns each have same radius of π cm. The currents in P and R are 1 A and 2 A respectively. P and Q are placed with their planes mutually perpendicular with their centers coincide. The resultant magnetic field induction at the center of the coils is \sqrt{x} mT, where $x =$ _____.

[Use $\mu_0 = 4\pi \times 10^{-7} \text{ TmA}^{-1}$]

Ans. (20)

Sol.

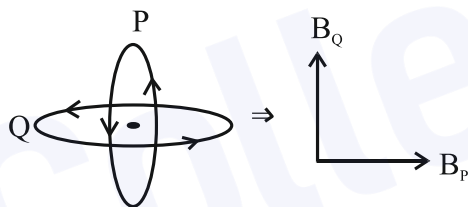

$$B_P = \frac{\mu_0 N i_1}{2r} = \frac{\mu_0 \times 1 \times 100}{2\pi} = 2 \times 10^{-3} \text{ T}$$

$$B_Q = \frac{\mu_0 N i_2}{2r} = \frac{\mu_0 \times 2 \times 100}{2\pi} = 4 \times 10^{-3} \text{ T}$$

$$B_{\text{net}} = \sqrt{B_P^2 + B_Q^2}$$

$$= \sqrt{20} \text{ mT}$$

$$x = 20$$

57. The distance between charges $+q$ and $-q$ is $2l$ and between $+2q$ and $-2q$ is $4l$. The electrostatic potential at point P at a distance r from centre O is $-\alpha \left[\frac{q\ell}{r^2} \right] \times 10^9 \text{ V}$, where the value of α is _____ . (Use $\frac{1}{4\pi\epsilon_0} = 9 \times 10^9 \text{ Nm}^2\text{C}^{-2}$)

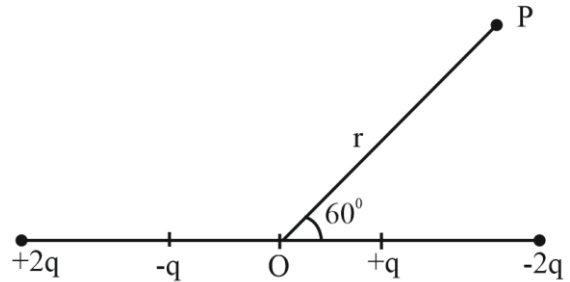

Ans. (27)

Sol.

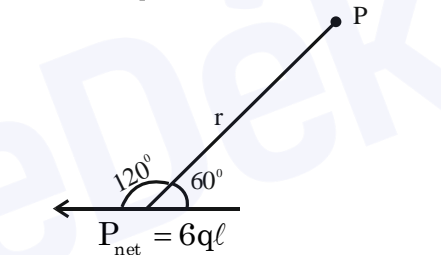
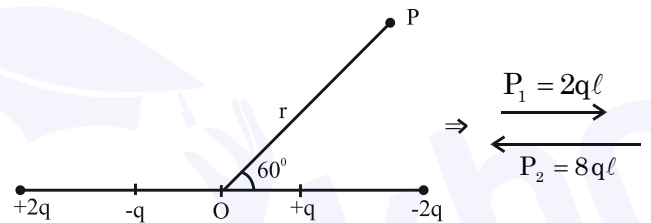

$$V = \frac{K \vec{p} \cdot \vec{r}}{r^3} = \frac{9 \times 10^9 (6q\ell)}{r^2} \cos(120^\circ)$$

$$= -(27) \left(\frac{q\ell}{r^2} \right) \times 10^9 \text{ Nm}^2\text{c}^{-2}$$

$$\Rightarrow \alpha = 27$$

58. Two identical spheres each of mass 2 kg and radius 50 cm are fixed at the ends of a light rod so that the separation between the centers is 150 cm. Then, moment of inertia of the system about an axis perpendicular to the rod and passing through its middle point is $\frac{x}{20} \text{ kg m}^2$, where the value of x is _____.

Ans. (53)

Sol.

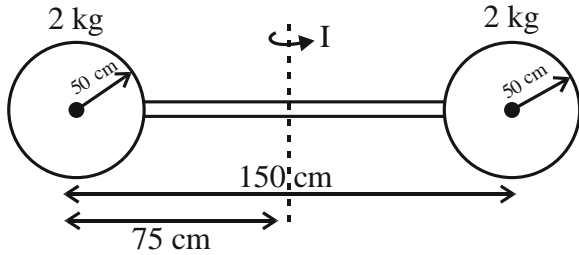

$$I = \left(\frac{2}{5} mR^2 + md^2 \right) \times 2$$

$$I = 2 \left(\frac{2}{5} \times 2 \times \left(\frac{1}{2} \right)^2 + 2 \times \left(\frac{3}{4} \right)^2 \right) = \frac{53}{20} \text{ kg-m}^2$$

$$X = 53$$

59. The time period of simple harmonic motion of mass M in the given figure is $\pi \sqrt{\frac{\alpha M}{5K}}$, where the value of α is _____.

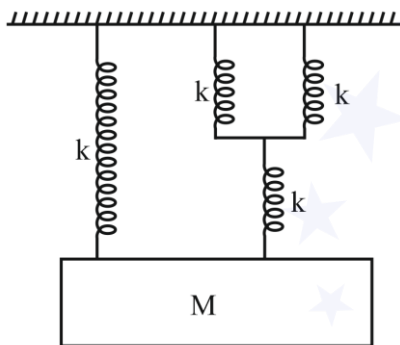

Ans. (12)

Sol. $k_{eq} = \frac{2k \cdot k}{3k} + k = \frac{5k}{3}$

Angular frequency of oscillation $(\omega) = \sqrt{\frac{k_{eq}}{m}}$

$$(\omega) = \sqrt{\frac{5k}{3m}}$$

Period of oscillation $(\tau) = \frac{2\pi}{\omega} = 2\pi \sqrt{\frac{3m}{5k}}$

$$= \pi \sqrt{\frac{12m}{5k}}$$

60. A nucleus has mass number A_1 and volume V_1 . Another nucleus has mass number A_2 and volume V_2 . If relation between mass number is $A_2 = 4A_1$, then $\frac{V_2}{V_1} = \underline{\hspace{2cm}}$.

Ans. (4)

Sol. For a nucleus

Volume: $V = \frac{4}{3} \pi R^3$

$$R = R_0 (A)^{1/3}$$

$$V = \frac{4}{3} \pi R_0^3 A$$

$$\Rightarrow \frac{V_2}{V_1} = \frac{A_2}{A_1} = 4$$