

FINAL JEE–MAIN EXAMINATION – APRIL, 2023

(Held On Thursday 06th April, 2023)

TIME : 9 : 00 AM to 12 : 00 NOON

SECTION-A

31. For the plane electromagnetic wave given by $E = E_0 \sin(\omega t - kx)$ and $B = B_0 \sin(\omega t - kx)$, the ratio of average electric energy density to average magnetic energy density is

- (1) 1 (2) 1/2
(3) 2 (4) 4

Official Ans. by NTA (1)

Ans. (1)

Sol.
$$\frac{\text{Electric energy density}}{\text{Magnetic energy density}} = \frac{\frac{1}{2} \epsilon_0 E_{\text{rms}}^2}{\left(\frac{B_{\text{rms}}^2}{2\mu_0}\right)}$$

$$= \left(\frac{E_{\text{rms}}}{B_{\text{rms}}}\right)^2 \cdot \mu_0 \epsilon_0 \quad \left[C = \frac{1}{\mu_0 \epsilon_0}\right]$$

$$= \frac{C^2}{C^2} = 1$$

32. Name the logic gate equivalent to the diagram attached

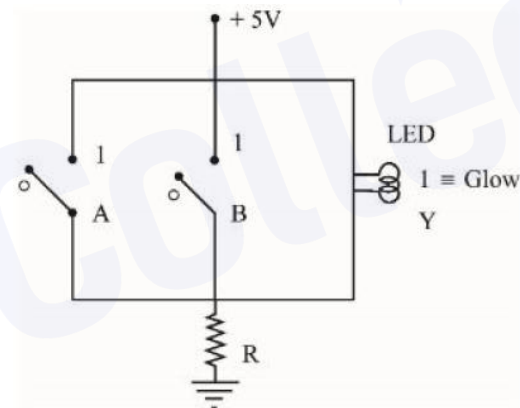

- (1) OR (2) NOR
(3) NAND (4) AND

Official Ans. by NTA (2)

Ans. (2)

Sol. Circuit is closed when neither A nor B is closed \Rightarrow current flows for $A = 0$ $B = 0$ when either or both of A & B is closed we get current bypass from switch

Hence it is “NOR” gate

33. A small ball of mass M and density ρ is dropped in a viscous liquid of density ρ_0 . After some time, the ball falls with a constant velocity. What is the viscous force on the ball ?

- (1) $F = Mg\left(1 - \frac{\rho_0}{\rho}\right)$ (2) $F = Mg\left(1 + \frac{\rho}{\rho_0}\right)$
(3) $F = Mg\left(1 + \frac{\rho_0}{\rho}\right)$ (4) $F = Mg(1 \pm \rho\rho_0)$

Official Ans. by NTA (1)

Ans. (1)

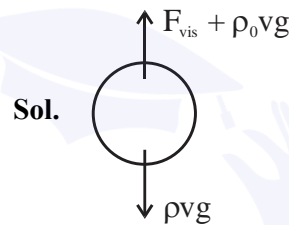

For constant velocity $F_{\text{net}} = 0$

$$F_{\text{vis}} + \rho_0 v g = \rho v g$$

$$F_{\text{vis}} = (\rho - \rho_0) v g$$

$$= \rho v g \left(1 - \frac{\rho_0}{\rho}\right)$$

$$= Mg \left(1 - \frac{\rho_0}{\rho}\right)$$

34. The number of air molecules per cm^3 increased from 3×10^{19} to 12×10^{19} . The ratio of collision frequency of air molecules before and after the increase in number respectively is

- (1) 1.25 (2) 0.25
(3) 0.75 (4) 0.50

Official Ans. by NTA (2)

Ans. (2)

Sol. Collision frequency,

$$f = \frac{V}{\lambda} = \frac{V}{\left(\frac{1}{\sqrt{2}\pi d^2 n_v}\right)} = \sqrt{2}\pi d^2 v n_v$$

$\therefore f \propto n_v$, n_v is number density

$$\frac{f_1}{f_2} = \frac{n_{v_1}}{n_{v_2}} = \frac{3 \times 10^{19}}{12 \times 10^{19}} = 0.25$$

35. A source supplies heat to a system at the rate of 1000 W. If the system performs work at a rate of 200 W. The rate at which internal energy of the system increases

- (1) 1200 W (2) 600 W
(3) 500 W (4) 800 W

Official Ans. by NTA (4)

Ans. (4)

Sol. $dQ = dU + dw$

$$\frac{dU}{dt} = \frac{dQ}{dt} - \frac{dw}{dt}$$

$$\frac{dU}{dt} = 1000 - 200 = 800 \text{ W}$$

36. A particle is moving with constant speed in a circular path. When the particle turns by an angle 90° , the ratio of instantaneous velocity to its average velocity is $\pi : x\sqrt{2}$. The value of x will be

- (1) 2 (2) 5
(3) 1 (4) 7

Official Ans. by NTA (1)

Ans. (1)

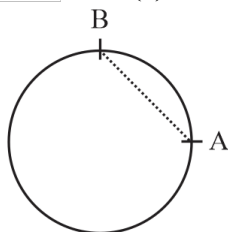

$$AB = R\sqrt{2}$$

Let instantaneous velocity be v. time,

$$t = \frac{\text{Arc length}}{v} = \frac{2\pi \frac{R}{4}}{v} = \frac{\pi R}{2v}$$

average velocity,

$$\langle v \rangle = \frac{AB}{t} = \frac{R\sqrt{2}(2v)}{\pi R} = \frac{2\sqrt{2}v}{\pi}$$

$$\Rightarrow \frac{V}{\langle V \rangle} = \frac{\pi}{2\sqrt{2}}$$

37. A small block of mass 100 g is tied to a spring of spring constant 7.5 N/m and length 20 cm. The other end of spring is fixed at a particular point A. If the block moves in a circular path on a smooth horizontal surface with constant angular velocity 5 rad/s about point A, then tension in the spring is

- (1) 1.5 N (2) 0.75 N
(3) 0.25 N (4) 0.50 N

Official Ans. by NTA (2)

Ans. (2)

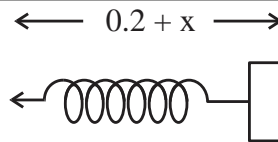

Sol.

$$kx \leftarrow \square \rightarrow m\omega^2 r$$

Let extension in length of spring be x.

Radius of circle $r = 0.2 + x$

$$Kx = m\omega^2 r$$

$$7.5x = \left(\frac{1}{10}\right)(5^2)(0.2 + x)$$

$$\Rightarrow \frac{15}{2}x = \frac{5}{2}\left(x + \frac{1}{5}\right)$$

$$\Rightarrow x = \frac{1}{10}$$

$$\therefore \text{Tension in spring} = kx = 7.5 \times \frac{1}{10} = 0.75 \text{ N}$$

38. A monochromatic light wave with wavelength λ_1 and frequency ν_1 in air enters another medium. If the angle of incidence and angle of refraction at the interface are 45° and 30° respectively, then the wavelength λ_2 and frequency ν_2 of the refracted wave are :

(1) $\lambda_2 = \lambda_1, \nu_2 = \sqrt{2}\nu_1$ (2) $\frac{1}{\sqrt{}}$

(3) $\lambda_2 = \sqrt{2}\lambda_1, \nu_2 = \nu_1$ (4) $\lambda_2 = \lambda_1, \nu_2 = \frac{1}{\sqrt{2}}\nu_1$

Official Ans. by NTA (2)

Ans. (2)

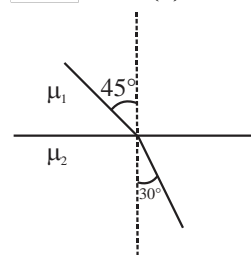

Sol.

$$\text{Snell's law } \mu_1 \sin 45^\circ = \mu_2 \sin 30^\circ$$

$$\frac{\mu_1}{\mu_2} = \frac{1}{\sqrt{2}}$$

$$\Rightarrow \frac{\mu_1}{\mu_2} = \frac{\lambda_2}{\lambda_1} = \frac{1}{\sqrt{2}}$$

$$\Rightarrow \lambda_2 = \frac{\lambda_1}{\sqrt{2}}$$

Frequency doesn't change on change in medium.

39. Given below are two statements : one is labelled as **Assertion A** and the other is labelled as **Reason R**.
Assertion A : When a body is projected at an angle 45° , its range is maximum.

Reason R : For maximum range, the value of $\sin 2\theta$ should be equal to one.

In the light of the above statements, choose the **correct** answer from the options given below :

(1) Both **A** and **R** are correct but **R** is **NOT** the correct explanation of **A**

(2) Both **A** and **R** are correct **R** is the correct explanation of **A**

(3) **A** is true but **R** is false

(4) **A** is false but **R** is true

Official Ans. by NTA (2)

Ans. (2)

Sol. $R = \frac{u^2}{g} \sin 2\theta$

R is maximum for $2\theta = 90^\circ$.

40. Two resistances are given as $R_1 = (10 \pm 0.5)\Omega$ and $R_2 = (15 \pm 0.5)\Omega$. The percentage error in the measurement of equivalent resistance when they are connected in parallel is

(1) 6.33 (2) 2.33

(3) 4.33 (4) 5.33

Official Ans. by NTA (3)

Ans. (3)

Sol. $\frac{1}{R} = \frac{1}{R_1} + \frac{1}{R_2}$

Differentiating both sides, we get

$$\frac{1}{R^2} \left(\frac{\Delta R_1}{R_1^2} + \frac{\Delta R_2}{R_2^2} \right) \left[R = \frac{R_1 R_2}{R_1 + R_2} = \frac{10 \times 15}{10 + 15} = 6 \right]$$

$$\Rightarrow \frac{\Delta R}{R} = \left(\frac{\Delta R_1}{R_1^2} + \frac{\Delta R_2}{R_2^2} \right) R$$

$$= \left(\frac{0.5}{10} + \frac{0.5}{225} \right) 6$$

$$= \left(\frac{6 \times 0.5}{25} \right) \left(\frac{1}{4} + \frac{1}{9} \right) = \frac{13}{300}$$

$$\frac{\Delta R}{R} \times 100 = \frac{13}{3} = 4.33\%$$

41. A planet has double the mass of the earth. Its average density is equal to the that of the earth. An object weighing W on earth will weigh on that planet :

(1) $2^{2/3} W$

(2) W

(3) $2^{1/3} W$

(4) $2 W$

Official Ans. by NTA (3)

Ans. (3)

Sol. $m = \rho \times \frac{4}{3} \pi R^3$

$$R \propto m^{1/3} (\rho = \text{constant})$$

$$\text{weight} = W \propto g \propto \frac{Gm}{R^2}$$

$$W \propto \frac{m}{m^{2/3}} \propto m^{1/3}$$

$$\text{So, } W^1 = (2)^{1/3} W$$

42. Given below are two statements : one is labelled as **Assertion A** and the other is labelled as **Reason R**.

Assertion A : Earth has atmosphere whereas moon doesn't have any atmosphere.

Reason R : The escape velocity on moon is very small as compared to that on earth.

In the light of the above statement, choose the **correct** answer from the options given below :

(1) **A** is true but **R** is false

(2) **A** is false but **R** is true

(3) Both **A** and **R** are correct but **R** is **NOT** the correct explanation of **A**

(4) Both **A** and **R** are correct and **R** is correct explanation of **A**

Official Ans. by NTA (4)

Ans. (4)

Sol. At Moon, due to low escape velocity, the rms velocity of molecules is greater than escape velocity. Hence molecules escape and there is no atmosphere at Moon.

43. For a uniformly charged thin spherical shell, the electric potential (V) radially away from the center (O) of shell can be graphically represented as

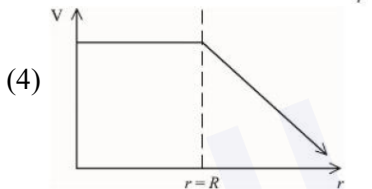
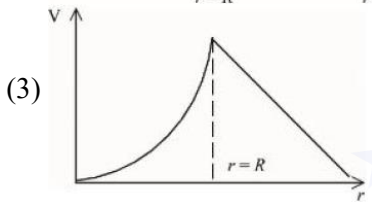
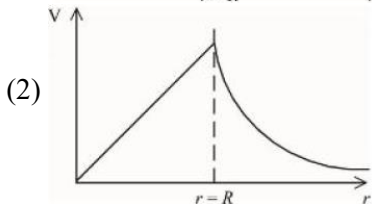
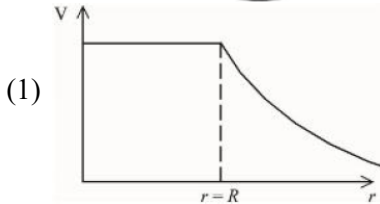
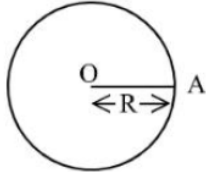

Official Ans. by NTA (1)

Ans. (1)

Sol.

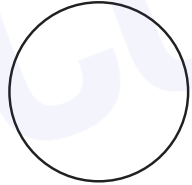

$$V_{\text{inside}} = \frac{kQ}{R}$$

$$V_{\text{outside}} = \frac{kQ}{r}$$

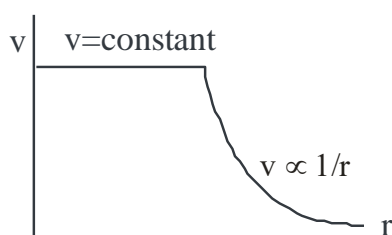

44. The resistivity (ρ) of semiconductor varies with temperature. Which of the following curve represents the correct behaviour

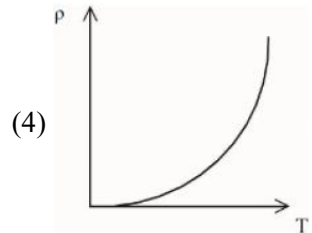
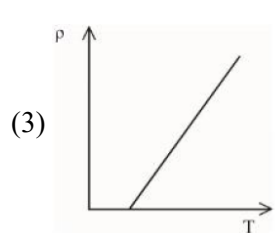
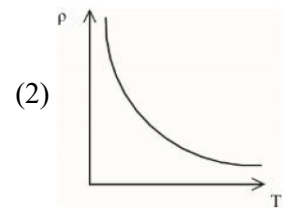
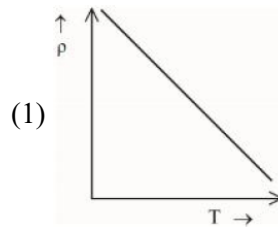

Official Ans. by NTA (2)

Ans. (2)

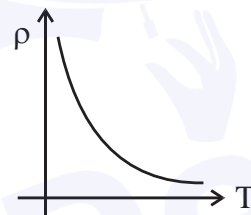

$$\rho = \frac{m}{ne^2\tau}$$

With rise in temperature, number density (n) of electrons and holes increases for semiconductors.

As m, e, τ are constant

$$\rho \propto \frac{1}{n} \Rightarrow \rho \propto \frac{1}{T} \text{ [Rectangular hyperbola]}$$

45. The kinetic energy of an electron, α -particle and a proton are given as 4K, 2K and K respectively. The de-Broglie wavelength associated with electron (λ_e) α -particle (λ_α) and the proton (λ_p) are as follows :

(1) $\lambda_\alpha = \lambda_p < \lambda_e$

(2) $\lambda_\alpha > \lambda_p > \lambda_e$

(3) $\lambda_\alpha < \lambda_p < \lambda_e$

(4) $\lambda_\alpha = \lambda_p > \lambda_e$

Official Ans. by NTA (3)

Ans. (3)

| | Electron | Alpha | Proton |
|----------------------------------|----------------------------------------------------|----------------------------------------|------------------------|
| Mass : | $\frac{m}{1840}$ | 4m | m |
| Charge : | e | 2e | e |
| Kinetic energy : | 4K | 2K | K |
| $\lambda = \frac{h}{\sqrt{2mK}}$ | $\frac{h}{\sqrt{2 \cdot \frac{m}{1840} \cdot 4K}}$ | $\frac{h}{\sqrt{2 \cdot 4m \cdot 2K}}$ | $\frac{h}{\sqrt{2mK}}$ |

Sol.

$$\lambda_\alpha < \lambda_p < \lambda_e$$

46. By what percentage will the transmission range of a TV tower be affected when the height of the tower is increased by 21% ?
- (1) 14% (2) 12%
 (3) 10% (4) 15%

Official Ans. by NTA (3)

Ans. (3)

Sol. Range, $R = \sqrt{2Rh}$

$$R_1 = \sqrt{2Rh_1}$$

$$h_2 = h_1 + \left(h_1 \times \frac{21}{100} \right) = 1.21h_1$$

$$\therefore R_2 = \sqrt{2Rh_2} = \sqrt{2R(1.21)h_1} = 1.1\sqrt{2Rh_1}$$

$$\therefore R_2 = 1.1 R_1$$

% increase in range

$$= \frac{R_2 - R_1}{R_1} \times 100 = \left(\frac{R_2}{R_1} - 1 \right) \times 100$$

$$= (1.1 - 1) \times 100 = 10\%$$

47. The energy levels of an hydrogen atom are shown below. The transition corresponding to emission of shortest wavelength is

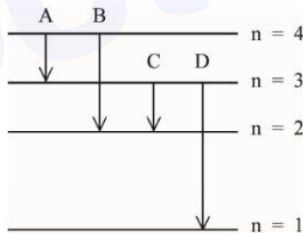

- (1) C (2) D
 (3) B (4) A

Official Ans. by NTA (2)

Ans. (2)

Sol. $\Delta E = \frac{hc}{\lambda} \Rightarrow \lambda \propto \frac{1}{\Delta E}$

For shortest wavelength, energy gap should be maximum.

So, correct choice is transition from $n = 3$ to $n = 1$.

48. A mass m is attached to two springs as shown in figure. The spring constants of two springs are K_1 and K_2 . For the frictionless surface, the time period of oscillation of mass m is

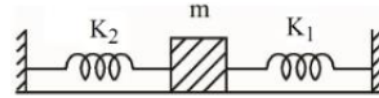

(1) $\frac{1}{2\pi} \sqrt{\frac{K_1 + K_2}{m}}$

(2) $\frac{1}{2\pi} \sqrt{\frac{K_1 - K_2}{m}}$

(3) $2\pi \sqrt{\frac{m}{K_1 + K_2}}$

(4) $2\pi \sqrt{\frac{m}{K_1 - K_2}}$

Official Ans. by NTA (3)

Ans. (3)

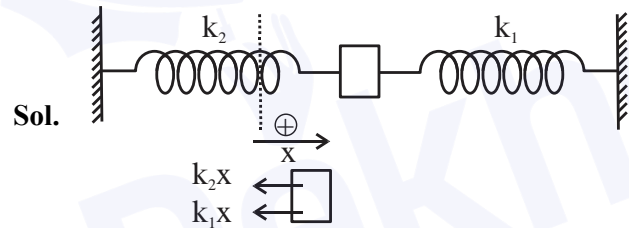

On displacing m to right by x

$$F = -(k_1x + k_2x) = -(k_1 + k_2)x$$

$$a = \frac{F}{m} = -\left(\frac{k_1 + k_2}{m} \right)x = -\omega^2 x$$

$$\therefore \omega = \sqrt{\frac{k_1 + k_2}{m}} \Rightarrow T = \frac{2\pi}{\omega} = 2\pi \sqrt{\frac{m}{k_1 + k_2}}$$

49. The induced emf can be produced in a coil by
- A. moving the coil with uniform speed inside magnetic field
 B. moving the coil with non-uniform speed inside uniform magnetic field
 C. rotating the coil inside the uniform magnetic field
 D. changing the area of the coil inside the uniform magnetic field

Choose the correct answer from the options given below:

- (1) B and D only (2) B and C only
 (3) A and C only (4) C and D only

Official Ans. by NTA (4)

Ans. (4)

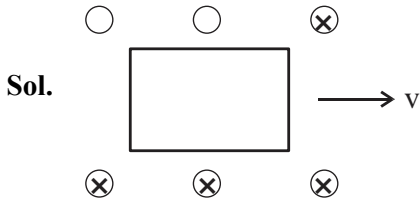

Moving a coil inside a uniform magnetic field either with uniform or non-uniform speed doesn't change flux, so, no emf is induced.

50. A long straight wire of circular cross-section (radius a) is carrying steady current I . The current I is uniformly distributed across this cross-section. The magnetic field is

- (1) Zero in the region $r < a$ and inversely proportional to r in the region $r > a$
- (2) Inversely proportional to r in the region $r < a$ and uniform throughout in the region $r > a$
- (3) Directly proportional to r in the region $r < a$ and inversely proportional to r in the region $r > a$
- (4) Uniform in the region $r < a$ and inversely proportional to distance r from the axis, in the region $r > a$

Official Ans. by NTA (3)

Ans. (3)

Sol.

$$\begin{cases} \frac{\mu_0 I r}{\pi a^2} & r \leq a \\ \frac{\mu_0 I}{\pi r^2} & r \geq a \end{cases}$$

SECTION-B

51. A pole is vertically submerged in swimming pool, such that it gives a length of shadow 2.15 m within water when sunlight is incident at an angle of 30° with the surface of water. If swimming pool is filled to a height of 1.5 m, then the height of the pole above the water surface in centimetres is ($n_w = 4/3$) _____.

Official Ans. by NTA (50)

Ans. (50)

Sol.

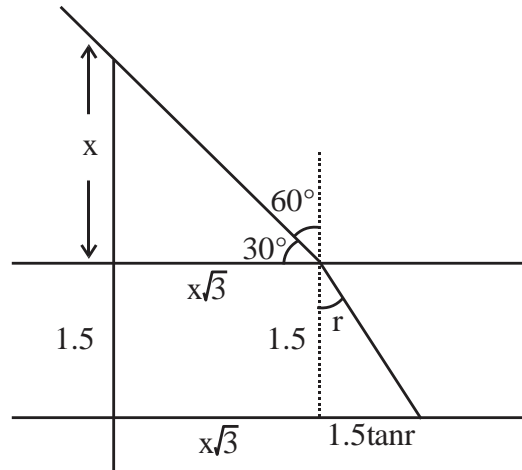

By Snell's law

$$1 \sin 60^\circ = \frac{4}{3} \sin r \rightarrow \sin r = \frac{3\sqrt{3}}{8} \rightarrow \tan r = \frac{3\sqrt{3}}{\sqrt{37}}$$

By the diagram

$$x\sqrt{3} + 1.5 \tan r = 2.15$$

$$x\sqrt{3} = 2.15 - 1.5 \times \frac{3\sqrt{3}}{\sqrt{37}}$$

$$x = \frac{2.15}{\sqrt{3}} - \frac{1.5 \times 3}{\sqrt{37}}$$

$$= 1.241 - 0.739$$

$$= 0.502$$

$$\approx 0.50 \text{ meter}$$

$$x = 50 \text{ cm}$$

52. The length of a metallic wire is increased by 20% and its area of cross section is reduced by 4%. The percentage change in resistance of the metallic wire is _____.

Official Ans. by NTA (25)

Ans. (25)

Sol. $R = \rho \frac{\ell}{A}$ be the initial resistance new resistance

$$R' = \rho \frac{1.2\ell}{0.96A} = 1.25\rho \frac{\ell}{A} = 1.25R$$

$$\text{percentage change} = \frac{1.25R - R}{R} \times 100 = 25\%$$

53. A particle of mass 10 g moves in a straight line with retardation $2x$, where x is the displacement in SI units. Its loss of kinetic energy for above displacement is $\left(\frac{10}{x}\right)^{-n}$ J. The value of n will be _____.

Official Ans. by NTA (2)

Ans. (2)

Sol. Loss of K.E = work done against retarding force.

$$\begin{aligned} &= \int_0^x m a dx = \int_0^x m 2x dx = mx^2 \\ &= (10^{-2} \text{ kg}) x^2 \text{ J} = \left(\frac{10}{x}\right)^{-2} \text{ J} \end{aligned}$$

So $n = 2$

54. Two identical circular wires of radius 20 cm and carrying current $\sqrt{2}$ A are placed in perpendicular planes as shown in figure. The net magnetic field at the centre of the circular wire is _____ $\times 10^{-8}$ T. (Take $\pi = 3.14$)

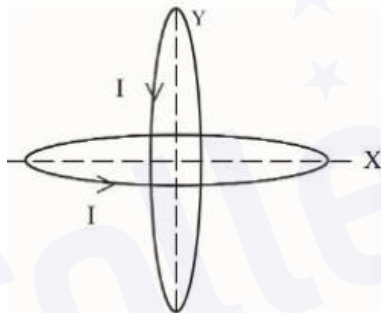

Official Ans. by NTA (628)

Ans. (628)

Sol. Magnetic field B_C at center $= \frac{\mu_0 i}{2r}$

$$= \frac{4\pi \times 10^{-7}}{2 \times 0.2} \times \sqrt{2} \text{ T}$$

Net magnetic field is

$$\begin{aligned} B_C \sqrt{2} &= \frac{4\pi \times 10^{-7} \times \sqrt{2}}{2 \times 0.2} \times \sqrt{2} \text{ T} = 2\pi \times 10^{-6} \text{ T} \\ &= 200\pi \times 10^{-8} \text{ T} \\ &= 2 \times 314 \times 10^{-8} \text{ T} \\ &= 628 \times 10^{-8} \text{ T} \end{aligned}$$

55. A person driving car at a constant speed of 15 m/s is approaching a vertical wall. The person notices a change of 40 Hz in the frequency of his car's horn upon reflection from the wall. The frequency of horn is _____ Hz.

(Given : Speed of sound : 330 m/s)

Official Ans. by NTA (420)

Ans. (420)

Sol. Frequency of reflected sound $= \left(\frac{v + v_c}{v - v_c}\right) f_0$

$$f = \left(\frac{330 + 15}{330 - 15}\right) \times f_0$$

$$= \frac{345}{315} f_0$$

$$\frac{345}{315} f_0 - f_0 = 40$$

$$\frac{30}{315} f_0 = 40$$

$$f_0 = \frac{4 \times 315}{3} = 420 \text{ Hz}$$

56. The radius of fifth orbit of the Li^{++} is _____ $\times 10^{-12}$ m. Take : radius of hydrogen atom = 0.51 Å

Official Ans. by NTA (425)

Ans. (425)

Sol. $r_n = r_0 \frac{n^2}{Z} \rightarrow r_n = 0.51 \times \frac{25}{3} \text{ Å} = 4.25 \times 10^{-10} \text{ m}$

$$= 425 \times 10^{-12} \text{ m}$$

57. A steel rod has a radius of 20 mm and a length of 2.0 m. A force of 62.8 kN stretches it along its length. Young's modulus of steel is 2.0×10^{11} N/m². The longitudinal strain produced in the wire is _____ $\times 10^{-5}$

Official Ans. by NTA (25)

Ans. (25)

Sol. Strain = $\frac{\text{stress}}{Y} = \frac{62.8 \times 10^3}{\pi \times (0.02)^2 \times 2 \times 10^{11}}$

$$= \frac{62.8 \times 10^3}{3.14 \times 4 \times 10^{-4} \times 2 \times 10^{11}}$$

$$= 2.5 \times 10^{-4}$$

$$= 25 \times 10^{-5}$$

- 58.** An ideal transformer with purely resistive load operates at 12 kV on the primary side. It supplies electrical energy to a number of nearby houses at 120 V. The average rate of energy consumption in the houses served by the transformer is 60 kW. The value of resistive load (R_s) required in the secondary circuit will be _____ $m\Omega$.

Official Ans. by NTA (240)

Ans. (240)

Sol. $v_p = 12 \times 10^3$ volts

$v_s = 120$ volts

$p_s = 60 \text{ KW} = v_s \times i_s$

$i_s = \frac{60 \times 10^3}{120} = 5 \times 10^2 \text{ A}$

$R_L = \frac{v_s}{i_s} = \frac{120}{5 \times 10^2} = 24 \times 10^{-2} = 240 \times 10^{-3} \Omega$

$= 240 \text{ m}\Omega$

- 59.** Two identical solid spheres each of mass 2 kg and radii 10 cm are fixed at the ends of a light rod. The separation between the centres of the spheres is 40 cm. The moment of inertia of the system about an axis perpendicular to the rod passing through its middle point is _____ $\times 10^{-3} \text{ kg-m}^2$

Official Ans. by NTA (176)

Ans. (176)

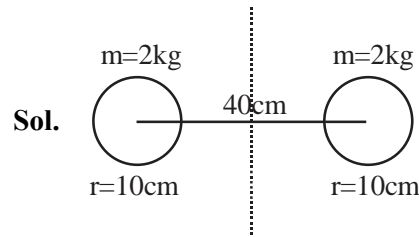

$$I = 2(I_{cm} + md^2)$$

$$= 2\left(\frac{2}{5}mr^2 + md^2\right)$$

$$= \frac{4}{5} \times 2 \times (0.1)^2 + 2(2)(0.20)^2$$

$$= \frac{8}{5} \times 10^{-2} + 16 \times 10^{-2}$$

$$= (1.6 + 16) \times 10^{-2}$$

$$= 17.6 \times 10^{-2}$$

$$I = 176 \times 10^{-3} \text{ kg m}^2$$

- 60.** A parallel plate capacitor with plate area A and plate separation d is filled with a dielectric material of dielectric constant $K = 4$. The thickness of the dielectric material is x , where $x < d$.



Let C_1 and C_2 be the capacitance of the system for $x = \frac{1}{3}d$ and $x = \frac{2d}{3}$, respectively. If $C_1 = 2\mu\text{F}$ the value of C_2 is _____ μF

Official Ans. by NTA (3)

Ans. (3)

Sol. For $x = \frac{d}{3}$

$$C_1 = \frac{\epsilon_0 A}{\left(\frac{d/3}{k} + \frac{2d}{3}\right)} = \frac{\epsilon_0 A}{\frac{d}{12} + \frac{2d}{3}}$$

$$= \frac{\epsilon_0 A}{d} \times \left(\frac{12}{9}\right)$$

$$C_1 = \frac{4}{3} \frac{\epsilon_0 A}{d} = 2\mu\text{F}$$

for $x = \frac{2d}{3}$

$$C_2 = \frac{\epsilon_0 A}{\left(\frac{2d/3}{k} + \frac{d}{3}\right)} = \frac{\epsilon_0 A}{d} \times 2$$

$$\Rightarrow \frac{6}{4} \times 2 = 3\mu\text{F}$$