

FINAL JEE–MAIN EXAMINATION – APRIL, 2023

(Held On Saturday 08th April, 2023)

TIME : 9 : 00 AM to 12 : 00 NOON

SECTION-A

31. A charge particle moving in magnetic field B, has the components of velocity along B as well as perpendicular to B. The path of the charge particle will be

- (1) helical path with the axis perpendicular to the direction of magnetic field B
- (2) straight along the direction of magnetic field B
- (3) helical path with the axis along magnetic field B
- (4) circular path

Official Ans. by NTA (3)

Ans. (3)

Sol.

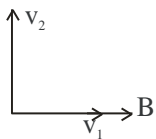

Due to component v_1 ,

$$\text{magnetic force } F = qv_1B\sin\theta=0$$

So v_1 remains unchanged

but due to component v_2 magnetic force act towards centre i.e. moving it circular. So path is helical with the axis parallel to magnetic field B.

32. Two projectiles A and B are thrown with initial velocities of 40 m/s and 60 m/s at angles 30° and 60° with the horizontal respectively. The ratio of their ranges respectively is ($g= 10 \text{ m/s}^2$)

- (1) $\sqrt{3} : 2$
- (2) $2 : \sqrt{3}$
- (3) $1 : 1$
- (4) $4 : 9$

Official Ans. by NTA (4)

Ans. (4)

Sol. $R_1 = \frac{u_1^2 \sin 2\theta_1}{g}; R_2 = \frac{u_2^2 \sin 2\theta_2}{g}$

$$\frac{R_1}{R_2} = \frac{u_1^2 \sin 2\theta_1}{u_2^2 \sin 2\theta_2} = \frac{40^2 \sin(2 \times 30^\circ)}{60^2 \sin(2 \times 60^\circ)} = \frac{4}{9}$$

33. Certain galvanometers have a fixed core made of non magnetic metallic material. The function of this metallic material is

- (1) to oscillate the coil in magnetic field for longer period of time
- (2) to bring the coil to rest quickly
- (3) to produce large deflecting torque on the coil
- (4) to make the magnetic field radial

Official Ans. by NTA (2)

Ans. (2)

Sol. Due to motion of the coil eddy current develops thus bringing the coil to rest.

34. A TV transmitting antenna is 98 m high and the receiving antenna is at the ground level. If the radius of the earth is 6400 km, the surface area covered by the transmitting antenna is approximately:

- (1) 1240 km²
- (2) 3942 km²
- (3) 4868 km²
- (4) 1549 km²

Official Ans. by NTA (2)

Ans. (2)

Sol. $h_T = 98\text{m}, h_R = 0, R = 6400 \text{ km}$

$$d = \sqrt{2h_T \cdot R} + \sqrt{2h_R \cdot R}$$

$$= \sqrt{2 \times 98 \times 6400 \times 10^3} + 0 = \frac{112}{\sqrt{10}} \text{ km}$$

So area = πd^2

$$= 3.14 \times \frac{112^2}{10} = 3942 \text{ km}^2$$

35. In a reflecting telescope, a secondary mirror is used to:

- (1) reduce the problem of mechanical support
- (2) remove spherical aberration
- (3) make chromatic aberration zero
- (4) move the eyepiece outside the telescopic tube

Official Ans. by NTA (4)

Ans. (4)

Sol.

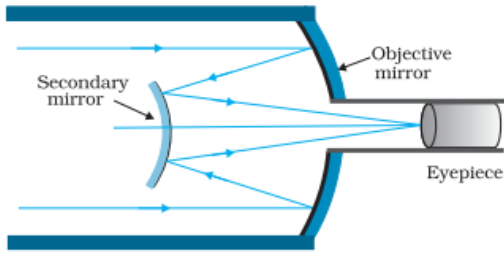

It has advantage of a large focal length in a short telescope

36. Given below are two statements:

Statement I: If heat is added to a system, its temperature must increase.

Statement II: If positive work is done by a system in a thermodynamic process, its volume must increase.

In the light of the above statements, choose the correct answer from the options given below

- (1) Statement I is true but Statement II is false
- (2) Both Statement I and Statement II are true
- (3) Both Statement I and Statement II are false
- (4) Statement I is false but Statement II is true

Official Ans. by NTA (4)

Ans. (4)

Sol. Statement I: $\Delta Q > 0$

According to 1st law of thermodynamics

$$\Delta Q = \Delta U + W$$

If $\Delta Q > 0$, $\Delta U < 0$ and $W > 0$ is also possible.

Hence $\Delta T < 0$, so T decreases.

Statement I is false

Statement II: $W > 0$

$$\therefore \int Pdv > 0$$

Therefore volume of system must increase during positive work done by the system.

Statement II is true

37. The weight of a body on the earth is 400 N. Then weight of the body when taken to a depth half of the radius of the earth will be:

- (1) Zero
- (2) 300 N
- (3) 100 N
- (4) 200 N

Official Ans. by NTA (4)

Ans. (4)

Sol. $W = mg = 400 \text{ N}$

$$\text{At depth } d, \text{ gravity } g' = g \left(1 - \frac{d}{R} \right)$$

$$\text{For } d = \frac{R}{2} \quad g' = g \left(1 - \frac{R}{2R} \right) = \frac{g}{2}$$

$$W' = mg' = \frac{mg}{2} = 200 \text{ N}$$

38. An aluminium rod with Young's modulus $Y = 7.0 \times 10^{10} \text{ N/m}^2$ undergoes elastic strain of 0.04%. The energy per unit volume stored in the rod in SI unit is:

- (1) 5600
- (2) 8400
- (3) 2800
- (4) 11200

Official Ans. by NTA (1)

Ans. (1)

Sol. $Y = 7 \times 10^{10} \text{ N/m}^2$

$$\text{Strain} = \frac{0.04}{100}$$

$$\text{Energy} = \frac{1}{2} \left(\frac{YA}{l} \right) \Delta x^2$$

$$\text{Energy} = \frac{1}{2} YA \left(\frac{\Delta x}{l} \right)^2 \times l$$

$$\frac{E}{V} = \frac{1}{2} \times Y \times \text{strain}^2$$

$$= \frac{1}{2} \times 7 \times 10^{10} \times \frac{0.04 \times 0.04}{10^4} = 56 \times 10^2$$

39. At any instant the velocity of a particle of mass 500 g is $(2t\hat{i} + 3t^2\hat{j})\text{ms}^{-1}$. If the force acting on the particle at $t=1\text{s}$ is $(\hat{i} + x\hat{j})\text{N}$. Then the value of x will be:

- (1) 3 (2) 4 (3) 6 (4) 2

Official Ans. by NTA (1)

Ans. (1)

Sol. $\vec{v} = 2t\hat{i} + 3t^2\hat{j}$

$\vec{a} = 2\hat{i} + 6t\hat{j}$

at $t=1, \vec{a} = 2\hat{i} + 6\hat{j}$

$\vec{F} = m\vec{a} = 0.5(2\hat{i} + 6\hat{j}) = \hat{i} + 3\hat{j}$

$\vec{F} = \hat{i} + x\hat{j}$ Hence $x = 3$

40. For the logic circuit shown, the output waveform at Y is:

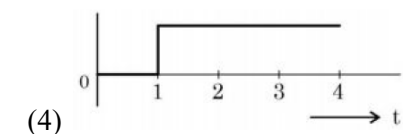
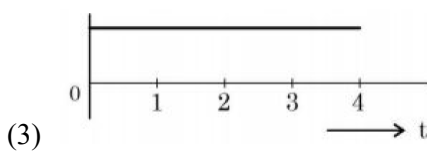
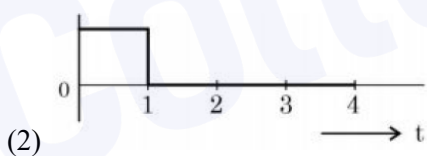
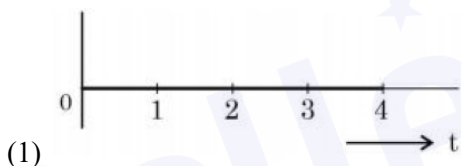
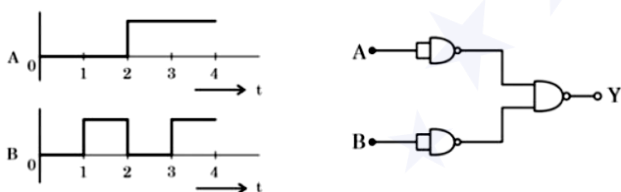

Official Ans. by NTA (4)

Ans. (4)

Sol.

A	B	Y
0	0	0
0	1	1
1	0	1
1	1	1

According to truth table, resultant graph is

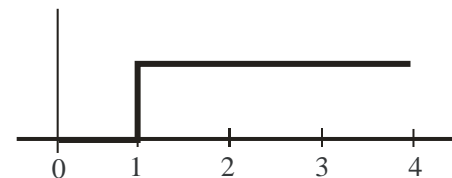

41. For a nucleus A_ZX having mass number A and atomic number Z

- A. The surface energy per nucleon $(b_s) = a_1A^{2/3}$
- B. The Coulomb contribution to the binding energy $b_c = -a_2 \frac{Z(Z-1)}{A^{4/3}}$
- C. The volume energy $b_v = a_3A$
- D. Decrease in the binding energy is proportional to surface area.
- E. While estimating the surface energy, it is assumed that each nucleon interacts with 12 nucleons, (a_1, a_2 and a_3 are constants)

Choose the **most appropriate** answer from the options given below:

- (1) C, D only (2) B, C, E only
- (3) A, B, C, D only (4) B, C only

Official Ans. by NTA (1)

Ans. (1)

Sol. Surface energy per nucleon $\propto \frac{r^2}{A} \propto \frac{A^{2/3}}{A} \propto \frac{1}{A^{1/3}}$

$(\text{Mass number } A \propto r^3 \Rightarrow r \propto A^{1/3})$.

A is incorrect

Contribution to binding energy by columbic forces is

$= \frac{-a_2Z(Z-1)}{A^{1/3}}$

B is incorrect

Volume energy $\propto A$

C is correct

For (D) , if we consider only surface energy contribution then option is correct.

For (E) only 3 interactions contribute to surface energy.

42. Given below are two statements:

Statement I :

If E be the total energy of a satellite moving around the earth, then its potential energy will be $\frac{E}{2}$.

Statement II:

The kinetic energy of a satellite revolving in an orbit is equal to the half the magnitude of total energy E.

In the light of the above statements, choose the most appropriate answer from the options given below

- (1) Both Statement I and Statement II are correct
- (2) Both Statement I and Statement II are incorrect
- (3) Statement I is incorrect but Statement II is correct
- (4) Statement I is correct but Statement II is incorrect

Official Ans. by NTA (2)

Ans. (2)

Sol. Energy of satellite in orbit $E = \frac{-GMm}{2R}$.

PE of satellite in orbit $U = \frac{-GMm}{R}$

$\Rightarrow U = 2E$

KE of satellite in orbit $K = E - U$

$K = \frac{GMm}{2R} = (-E)$

43. Dimension of $\frac{1}{\mu_0 \epsilon_0}$ should be equal to

- (1) T^2/L^2
- (2) L/T
- (3) L^2/T^2
- (4) T/L

Official Ans. by NTA (3)

Ans. (3)

Sol. $\frac{1}{\mu_0 \epsilon_0} = c^2 \Rightarrow \left[\frac{1}{\mu_0 \epsilon_0} \right] = [c^2] = [L^2 T^{-2}]$

44. In this figure the resistance of the coil of galvanometer G is 2Ω . The emf of the cell is 4 V. The ratio of potential difference across C_1 and C_2 is:

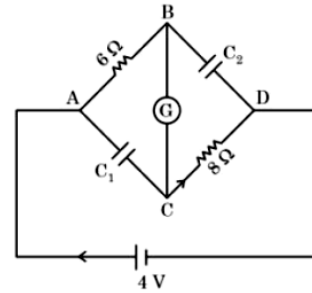

- (1) 1
- (2) $\frac{4}{5}$
- (3) $\frac{3}{4}$
- (4) $\frac{5}{4}$

Official Ans. by NTA (2)

Ans. (2)

Sol. At steady state, current in the circuit is

$i = \frac{4V}{6+2+8} = \frac{1}{4} A$

Voltage across C_1 is

$V_1 = V_{AC} = i(6\Omega + 2\Omega) = \frac{1}{4} \times 8 = 2V$

Voltage across C_2 is

$V_2 = V_{BD} = i(2\Omega + 8\Omega) = \frac{1}{4} \times 10 = 2.5V$

$\Rightarrow \frac{V_1}{V_2} = \frac{2}{2.5} = \frac{4}{5}$

45. Graphical variation of electric field due to a uniformly charged insulating solid sphere of radius R, with distance r from the centre O is represented by:

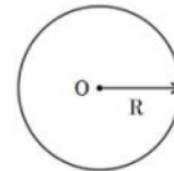

- (1)
- (2)
- (3)
- (4)

Official Ans. by NTA (1)

Ans. (1)

Sol. Electric field of solid sphere (uniformly charged)

$$E(r) \begin{cases} \frac{Q}{4\pi \epsilon_0 r^2} & r \geq R \\ \frac{Qr}{4\pi \epsilon_0 R^3} & r \leq R \end{cases}$$

Graphically

$$E(r) \propto r \text{ for } r \leq R$$

$$\propto \frac{1}{r^2} \text{ for } r \geq R$$

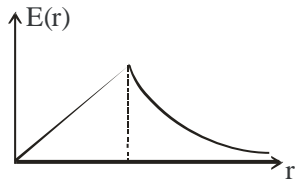

46. Two forces having magnitude A and $\frac{A}{2}$ are perpendicular to each other. The magnitude of their resultant is

- (1) $\frac{\sqrt{5}A}{4}$ (2) $\frac{5A}{2}$
 (3) $\frac{\sqrt{5}A^2}{2}$ (4) $\frac{\sqrt{5}A}{2}$

Official Ans. by NTA (4)

Ans. (4)

Sol.

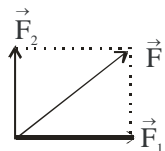

$$\vec{F} = (\vec{F}_1 + \vec{F}_2)$$

$$|\vec{F}| = \sqrt{F_1^2 + F_2^2 + 2F_1F_2 \cos 90^\circ}$$

$$= \sqrt{A^2 + \frac{A^2}{4}} = \frac{A\sqrt{5}}{2}$$

47. The engine of a train moving with speed 10ms^{-1} towards a platform sounds a whistle at frequency 400Hz . The frequency heard by a passenger inside the train is (neglect air speed. Speed of sound in air 330ms^{-1})

- (1) 200Hz (2) 400Hz
 (3) 412Hz (4) 388Hz

Official Ans. by NTA (2)

Ans. (2)

Sol. The relative velocity of a passenger with source of sound (engine) is 0. So there will be no doppler's effect. So frequency heard is 400Hz .

48. An air bubble of volume 1cm^3 rises from the bottom of a lake 40m deep to the surface at a temperature of 12°C . The atmospheric pressure is $1 \times 10^5\text{Pa}$, the density of water is 1000kg/m^3 and $g = 10\text{m/s}^2$. There is no difference of the temperature of water at the depth of 40m and on the surface. The volume of air bubble when it reaches the surface will be

- (1) 5cm^3 (2) 2cm^3
 (3) 4cm^3 (4) 3cm^3

Official Ans. by NTA (1)

Ans. (1)

Sol. $P = P_0 + \rho gh = 10^5\text{Pa} + 10^3 \times 10 \times 40 = 5 \times 10^5\text{Pa}$

At T is constant

$$PV = P_0V_0$$

$$\Rightarrow 5 \times 10^5\text{Pa} \times 1\text{cm}^3 = 10^5\text{Pa} \times V_0 \Rightarrow V_0 = 5\text{cm}^3$$

49. A cylindrical wire of mass $(0.4 \pm 0.01)\text{g}$ has length $(8 \pm 0.04)\text{cm}$ and radius $(6 \pm 0.03)\text{mm}$. The maximum error in its density will be

- (1) 1% (2) 3.5%
 (3) 4% (4) 5%

Official Ans. by NTA (3)

Ans. (3)

Sol. $\rho = \frac{m}{\pi r^2 l} \Rightarrow \left| \frac{d\rho}{\rho} \right|_{\max} = \left| \frac{dm}{m} \right| + 2 \left| \frac{dr}{r} \right| + \left| \frac{dl}{l} \right|$

$$= \frac{0.01}{0.4} + \frac{2(0.03)}{6} + \frac{0.04}{8}$$

$$\Rightarrow \% \text{ error in density} = \left(\frac{d\rho}{\rho} \right) \times 100\%$$

$$= (2.5 + 1 + 0.5)\% = 4\%$$

50. Proton (P) and electron (e) will have same de-Broglie wavelength when the ratio of their momentum is (assume, $m_p = 1849m_e$)

(1) 1 : 43 (2) 43 : 1

(3) 1 : 1849 (4) 1 : 1

Official Ans. by NTA (4)

Ans. (4)

Sol. De Broglie wavelength is $\lambda = \frac{h}{mv}$

$$\lambda_p = \lambda_e \Rightarrow m_p v_p = m_e v_e \Rightarrow p_p = p_e$$

SECTION-B

51. An electric dipole of dipole moment is $6.0 \times 10^{-6} \text{ Cm}$ placed in a uniform electric field of $1.5 \times 10^3 \text{ NC}^{-1}$ in such a way that dipole moment is along electric field. The work done in rotating dipole by 180° in this field will be _____ mJ

Official Ans. by NTA (18)

Ans. (18)

Sol. The work done in rotating the electric dipole = ΔU

$$= U_f - U_i$$

$$= (-pE \cos(180^\circ)) - (-pE \cos(0^\circ))$$

$$= pE + pE = 2pE$$

$$= 2 \times 6 \times 10^{-6} \times 1.5 \times 10^3 = 18 \text{ mJ}$$

52. Two vertical parallel mirrors A and B are separated by 10 cm. A point object O is placed at a distance of 2 cm from mirror A. The distance of the second nearest image behind mirror A from the mirror A is _____ cm

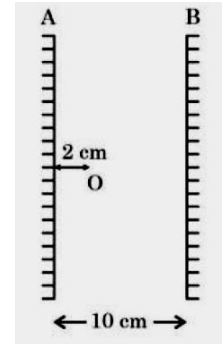

Official Ans. by NTA (18)

Ans. (18)

Sol.

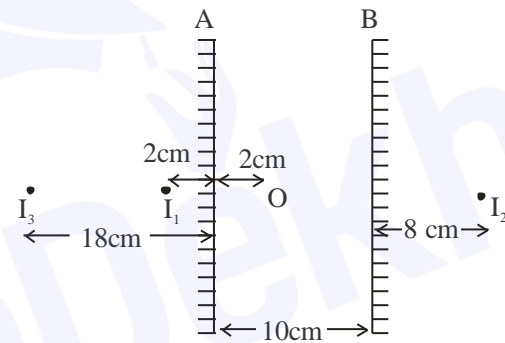

The desired image is 18 cm from A.

53. The momentum of a body is increased by 50%. The percentage increase in the kinetic energy of the body is _____ %

Official Ans. by NTA (125)

Ans. (125)

Sol. Kinetic energy of body = $\frac{p^2}{2m}$

$$\text{Initial kinetic energy} = \frac{p_i^2}{2m}$$

$$\text{Final kinetic energy} = \frac{p_f^2}{2m} = \frac{(1.5 p_i)^2}{2m}$$

$$\frac{\text{Final KE} - \text{Initial KE}}{\text{Initial KE}} = \frac{2.25 p_i^2}{2m} - \frac{p_i^2}{2m}$$

$$\% \text{ increase in KE} = \frac{2.25 \frac{p_i^2}{2m} - \frac{p_i^2}{2m}}{\frac{p_i^2}{2m}} \times 100 = 125\%$$

54. The moment of inertia of semicircular ring about an axis, passing through the center and perpendicular to the plane of ring, is $\frac{1}{x}MR^2$, where R is the radius and M is the mass of semicircular ring. The value of x will be

Official Ans. by NTA (1)

Ans. (1)

- Sol.** The moment of inertia of semicircular ring about axis passing through centre of ring and perpendicular to plane of ring is $= MR^2$
so $x = 1$

55. An organ pipe 40cm long is open at both ends. The speed of sound in air is 360ms^{-1} . The frequency of the second harmonic is ___ Hz.

Official Ans. by NTA (900)

Ans. (900)

Sol.

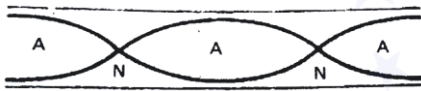

For second harmonic of open organ pipe

$$L = \lambda$$

So frequency of vibration is $f = \frac{V}{\lambda}$

$$f = \frac{V}{\frac{360}{40}} = 900\text{Hz}$$

56. An air bubble of diameter 6 mm rises steadily through a solution of density _____ at the rate of 0.35 cm/s. The co-efficient of viscosity of the solution (neglect density of air) is ___ Pas (given, $g = 10\text{ms}^{-2}$)

Official Ans. by NTA (10)

Ans. (10)

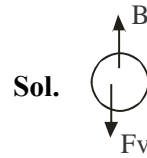

Since the bubble is moving at constant speed the force acting on it is zero.

$$B = F_v$$

$$\frac{4}{3}\pi R^3 \rho g = 6\pi \eta R v$$

$$\eta = \frac{2R^2 \rho g}{9v} = \frac{2 \times (3 \times 10^{-3})^2 \times 1750 \times 10}{9 \times 0.35 \times 10^{-2}} = 10\text{Pas}$$

57. An oscillating LC circuit consists of a 75 mH inductor and a $1.2\mu\text{F}$ capacitor. If the maximum charge to the capacitor is $2.7\mu\text{C}$. The maximum current in the circuit will be ___ mA.

Official Ans. by NTA (9)

Ans. (9)

- Sol.** Maximum energy stored in capacitor is same as maximum energy stored in inductor.

$$\frac{1}{2} Li_{\text{max}}^2 = \frac{1}{2} \frac{Q_{\text{max}}^2}{C}$$

$$i_{\text{max}} = \sqrt{\frac{Q_{\text{max}}^2}{LC}}$$

$$= \frac{2.7 \times 10^{-6}}{\sqrt{75 \times 10^{-3} \times 1.2 \times 10^{-6}}} = 9\text{mA}$$

58. The magnetic intensity at the centre of a long current carrying solenoid is found to be $1.6 \times 10^3 \text{Am}^{-1}$. If the number of turns is 8 per cm, then the current flowing through the solenoid is ___ A.

Official Ans. by NTA (2)

Ans. (2)

Sol. $H = \frac{B}{\mu_0} = \frac{\mu_0 ni}{\mu_0} = ni$

$$i = \frac{H}{n} = \frac{1.6 \times 10^3}{\left(\frac{8}{10^{-2}}\right)} = 2\text{A}$$

59. A current of 2 A flows through a wire of cross-sectional area 25.0 mm^2 . The number of free electrons in a cubic meter are 2.0×10^{28} . The drift velocity of the electrons is $\text{_____} \times 10^{-6} \text{ ms}^{-1}$ (given, charge on electron = $1.6 \times 10^{-19} \text{ C}$)

Official Ans. by NTA (25)

Ans. (25)

Sol. Drift velocity $v_d = \frac{I}{neA}$

$$= \frac{2}{2 \times 10^{28} \times 1.6 \times 10^{-19} \times 25 \times 10^{-6}}$$

$$= 25 \times 10^{-6} \text{ ms}^{-1}$$

60. A nucleus with mass number 242 and binding energy per nucleon as 7.6 MeV breaks into fragment each with mass number 121. If each fragment nucleus has binding energy per nucleon as 8.1 MeV, the total gain in binding energy is _____ MeV

Official Ans. by NTA (121)

Ans. (121)

- Sol.** Initial binding energy = $242 \times 7.6 \text{ MeV}$
Final binding energy

$$= 121 \times 8.1 \text{ MeV} + 121 \times 8.1 \text{ MeV}$$

$$= 242 \times 8.1 \text{ MeV}$$

Total gain in binding energy

$$= 242 (8.1 - 7.6) = 121 \text{ MeV}$$