

FINAL JEE–MAIN EXAMINATION – APRIL, 2023

(Held On Monday 10th April, 2023)

TIME : 3 : 00 PM to 6 : 00 PM

SECTION-A

31. A person travels x distance with velocity v_1 and then x distance with velocity v_2 in the same direction. The average velocity of the person is v , then the relation between v , v_1 and v_2 will be :

(1) $v = v_1 + v_2$

(2) $v = \frac{v_1 + v_2}{2}$

(3) $\frac{2}{v} = \frac{1}{v_1} + \frac{1}{v_2}$

(4) $\frac{1}{v} = \frac{1}{v_1} + \frac{1}{v_2}$

Official Ans. by NTA (3)

Ans. (3)

Sol. Average velocity = $\frac{x+x}{\frac{x}{v_1} + \frac{x}{v_2}} = v$

$$\frac{1}{v_1} + \frac{1}{v_2} = \frac{2}{v}$$

32. The half-life of a radioactive substance is T . The time taken, for disintegrating $\frac{7}{8}$ th part of its original mass will be :

(1) $3T$

(2) $8T$

(3) T

(4) $2T$

Official Ans. by NTA (1)

Ans. (1)

Sol. $t_{1/2} = T$

$$1 \xrightarrow{T} \frac{1}{2} \xrightarrow{T} \frac{1}{4} \xrightarrow{T} \frac{1}{8}$$

$t_{7/8} = 3T$

33. A gas mixture consists of 2 moles of oxygen and 4 moles of neon at temperature T . Neglecting all vibrational modes, the total internal energy of the system will be :

(1) $8 RT$

(2) $16 RT$

(3) $4 RT$

(4) $11 RT$

Official Ans. by NTA (4)

Ans. (4)

Sol. $(C_v)_{\text{mix}} = \frac{n_1 C_{v1} + n_2 C_{v2}}{n_1 + n_2}$

$$(C_v)_{\text{mix}} = \frac{2 \times \frac{5}{2} R + 4 \times \frac{3}{2} R}{2 + 4} = \frac{11R}{6}$$

$$\Delta U = n(C_v)_{\text{mix}} RT = 6 \frac{11R}{6} \times RT = 11R$$

34. In an experiment with Vernier callipers of least count 0.1 mm, when two jaws are joined together the zero of Vernier scale lies right to the zero of the main scale and 6^{th} division of Vernier scale coincides with the main scale division. While measuring the diameter of a spherical bob, the zero of vernier scale lies in between 3.2 cm and 3.3 cm marks, and 4^{th} division of vernier scale coincides with the main scale division. The diameter of bob is measured as :

(1) 3.18 cm

(2) 3.25 cm

(3) 3.26 cm

(4) 3.22 cm

Official Ans. by NTA (1)

Ans. (1)

Sol. $LC = 0.1$ mm

Zero Error = $6 \times LC = 0.6$ mm

Reading = $MSR + VSR \times LC - \text{Zero Error}$

= $[32\text{mm} + (0.1)4\text{mm}] - 0.6\text{mm}$

= 31.8 mm

= 3.18 cm

35. Given below are two statements:

Statement I: For diamagnetic substance $-1 \leq \chi < 0$, where χ is the magnetic susceptibility.

Statement II: Diamagnetic substances when placed in an external magnetic field, tend to move from stronger to weaker part of the field.

In the light of the above statements, choose the correct answer from the options given below.

- (1) Both Statement I and Statement II are false.
- (2) Both Statement I and Statement II are true.
- (3) Statement I is incorrect but Statement II is true.
- (4) Statement I is correct but Statement II is false.

Official Ans. by NTA (2)

Ans. (2)

Sol. Both Statements are correct.

36. The distance between two plates of a capacitor is d and its capacitance is C_1 , when air is the medium between the plates. If a metal sheet of thickness $\frac{2d}{3}$ and of same area as plate is introduced between the plates, the capacitance of the capacitor becomes C_2 . The ratio $\frac{C_2}{C_1}$ is:

- (1) 2 : 1
- (2) 4 : 1
- (3) 3 : 1
- (4) 1 : 1

Official Ans. by NTA (3)

Ans. (3)

Sol. $K_{\text{metal sheet}} = \infty$, $t = \frac{2d}{3}$

$$C_1 = \frac{\epsilon_0 A}{d}$$

$$C_2 = \frac{\epsilon_0 A}{d - t + \frac{t}{\infty}} = \frac{\epsilon_0 A}{d - \frac{2d}{3} + 0} = 3C_1$$

$$\frac{C_2}{C_1} = 3$$

37. Given below are two statements:

Statement I: Rotation of the earth shows effect on the value of acceleration due to gravity (g).

Statement II: The effect of rotation of the earth on the value of 'g' at the equator is minimum and that at the pole is maximum.

In the light of the above statements, choose the correct answer from the options given below.

- (1) Statement I is false but Statement II is true.
- (2) Statement I is true but Statement II are false.
- (3) Both Statement I and Statement II are true.
- (4) Both Statement I and Statement II are false.

Official Ans. by NTA (2)

Ans. (2)

Sol. Statement I is true due to centrifugal force.

Statement II is incorrect,

At pole $g = g_s$ (no effect)

At equator $g = g_s - r\omega^2 \cos^2 \lambda = g_s - r\omega^2$

$\therefore (\cos^2 \lambda_{\text{maximum}} \text{ at } \lambda = 0^\circ \text{ i.e. at equator})$

Effect is maximum at equator.

38. The time period of a satellite, revolving above earth's surface at a height equal to R will be

(Given $g = \pi^2 \text{ m/s}^2$, $R = \text{radius of earth}$)

- (1) $\sqrt{4R}$
- (2) $\sqrt{8R}$
- (3) $\sqrt{32R}$
- (4) $\sqrt{2R}$

Official Ans. by NTA (3)

Ans. (3)

Sol. $\frac{mv^2}{2R} = \frac{GMm}{(2R)^2} \Rightarrow v = \sqrt{\frac{GM}{2R}} = \sqrt{\frac{Rg}{2}}$

$$T = \frac{2\pi(2R)}{v} = \frac{4\pi R \sqrt{2}}{\sqrt{Rg}} = \sqrt{32R}$$

39. Given below are two statements: one is labelled as **Assertion A** and the other is labelled as **Reason R**.
Assertion A: An electric fan continues to rotate for some time after the current is switched off.

Reason R: Fan continues to rotate due to inertia of motion.

In the light of above statements, choose the most appropriate answer from the options given below.

- (1) **A** is correct but **R** is not correct.
- (2) Both **A** and **R** are correct and **R** is the correct explanation of **A**.
- (3) **A** is not correct but **R** is correct.
- (4) Both **A** and **R** are correct but **R** is **NOT** the correct explanation of **A**.

Official Ans. by NTA (2)

Ans. (2)

Sol. Fact

40. The amplitude of magnetic field in an electromagnetic wave propagating along y-axis is 6.0×10^{-7} T. The maximum value of electric field in the electromagnetic wave is:

- (1) $5 \times 10^{14} \text{ Vm}^{-1}$
- (2) 180 Vm^{-1}
- (3) $2 \times 10^{15} \text{ Vm}^{-1}$
- (4) $6.0 \times 10^{-7} \text{ Vm}^{-1}$

Official Ans. by NTA (2)

Ans. (2)

Sol. E

$$E = BC$$

$$= 6 \times 10^{-7} \times 3 \times 10^8$$

$$= 18 \times 10$$

$$E = 180 \text{ Vm}^{-1}$$

41. A gas is compressed adiabatically, which one of the following statement is NOT true.

- (1) There is no heat supplied to the system
- (2) The temperature of the gas increases
- (3) The change in the internal energy is equal to the work done on the gas.
- (4) There is no change in the internal energy

Official Ans. by NTA (4)

Ans. (4)

Sol. (1) $\Delta Q = 0$
 (2) $\Delta Q = \Delta U + \Delta W$
 $\Rightarrow \Delta U = -\Delta W$
 adiabatic compression ($V \downarrow$)
 $\Delta W = -ve \Rightarrow \Delta U = +ve$
 $\Delta U \uparrow \Rightarrow T \uparrow$
 $\Delta U \neq 0$

42. The ratio of intensities at two points P and Q on the screen in a Young's double slit experiment where phase difference between two wave of same amplitude are $\pi/3$ and $\pi/2$, respectively are

- (1) 1 : 3
- (2) 3 : 1
- (3) 3 : 2
- (4) 2 : 3

Official Ans. by NTA (3)

Ans. (3)

Sol. $I_{\text{net}} = I_1 + I_2 + 2\sqrt{I_1 I_2} \cos \phi$

$$= I_0 + I_0 + 2I_0 \cos \frac{\pi}{3}$$

$$= 2I_0 + 2I_0 \times \frac{1}{2} = 3I_0$$

$$I_{\text{net}} = I_0 + I_0 + 2I_0 \cos 90^\circ = 2I_0$$

$$\text{Ratio} = \frac{3}{2}$$

43. The variation of stopping potential (V_0) as a function of the frequency (ν) of the incident light for a metal is shown in figure. The work function of the surface is

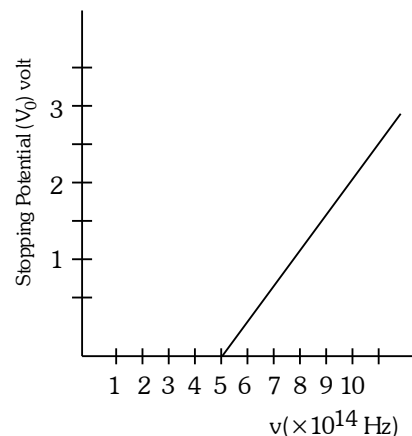

- (1) 18.6 eV
- (2) 2.98 eV
- (3) 2.07 eV
- (4) 1.36 eV

Official Ans. by NTA (3)

Ans. (3)

Sol. $eV_0 = hv - \phi$

$0 = hv - \phi$

$\phi = hv$

$= 6.6 \times 10^{-34} \times 5 \times 10^{14}$

$= 33 \times 10^{-20} \text{ J}$

$\phi = \frac{33 \times 10^{-20}}{1.6 \times 10^{-19}} = 2.07 \text{ eV}$

44. For a periodic motion represented by the equation

$Y = \sin \omega t + \cos \omega t$

The amplitude of the motion is

(1) 0.5 (2) $\sqrt{2}$

(3) 1 (4) 2

Official Ans. by NTA (2)

Ans. (2)

Sol. $y = \sin \omega t + \cos \omega t$

$y = \sin \omega t + \sin (\omega t + \frac{\pi}{2})$

$\Delta\phi = \frac{\pi}{2}$

$A_{\text{net}} = \sqrt{1^2 + 1^2 + 2 \times 1 \times 1 \times \cos(\Delta\phi)}$

$A_{\text{net}} = \sqrt{2}$

45. In a metallic conductor, under the effect of applied electric field, the free electrons of the conductor

- (1) drift from higher potential to lower potential.
- (2) move in the curved paths from lower potential to higher potential
- (3) move with the uniform velocity throughout from lower potential to higher potential
- (4) move in the straight line paths in the same direction

Official Ans. by NTA (2)

Ans. (2)

Sol. Move in curve path

$i = neAV_d$

46. Young's moduli of the material of wires A and B are in the ratio of 1 : 4, while its area of cross sections are in the ratio of 1 : 3. If the same amount of load is applied to both the wires, the amount of elongation produced in the wires A and B will be in the ratio of

[Assume length of wires A and B are same]

- (1) 36 : 1 (2) 12 : 1
- (3) 1 : 36 (4) 1 : 12

Official Ans. by NTA (2)

Ans. (2)

Sol. $\Delta L = \frac{FL}{AY}$

$\frac{\Delta L_A}{\Delta L_B} = \frac{A_B Y_B}{A_A Y_A} = 12$

47. Two projectiles are projected at 30° and 60° with the horizontal with the same speed. The ratio of the maximum height attained by the two projectiles respectively is:

- (1) $2 : \sqrt{3}$ (2) $\sqrt{3} : 1$
- (3) 1 : 3 (4) $1 : \sqrt{3}$

Official Ans. by NTA (3)

Ans. (3)

Sol. $H_{\text{max}} = \frac{u^2 \sin^2 \theta}{2g}$

$\frac{H_1}{H_2} = \frac{\sin^2 \theta_1}{\sin^2 \theta_2} = \frac{1}{3}$

48. A message signal of frequency 3kHz is used to modulate a carrier signal of frequency 1.5 MHz. The bandwidth of the amplitude modulated wave is

- (1) 3 kHz (2) 6 MHz
- (3) 3 MHz (4) 6 kHz

Official Ans. by NTA (4)

Ans. (4)

Sol. Bandwidth = $2f_m$
 $= 2 \times 3 \text{ kHz}$
 $= 6 \text{ kHz}$

49. If each diode has a forward bias resistance of $25\ \Omega$ in the below circuit,

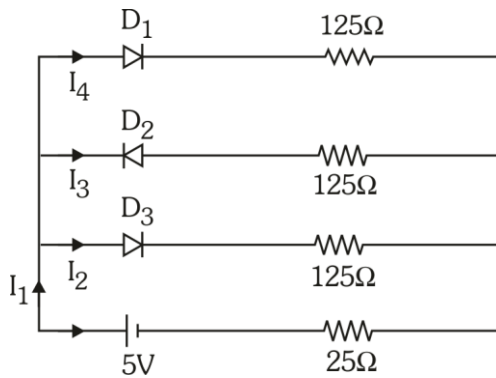

Which of the following options is correct:

- (1) $\frac{I_3}{I_4} = 1$ (2) $\frac{I_2}{I_3} = 1$
 (3) $\frac{I_1}{I_2} = 1$ (4) $\frac{I_1}{I_2} = 2$

Official Ans. by NTA (4)

Ans. (4)

Sol.

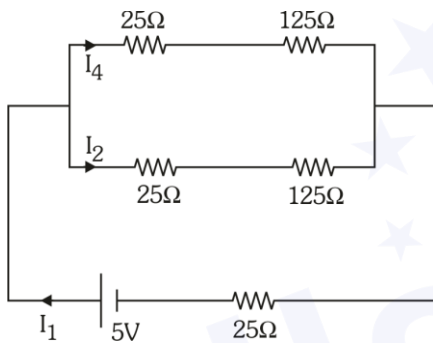

$$R_{eq} = \frac{150 \times 150}{300} + 25 = 100\ \Omega$$

$$I_1 = \frac{5}{10} = 0.05\text{A}$$

$$I_2 = I_4 = \frac{0.05}{2} = 0.025\text{A}$$

$$\frac{I_1}{I_2} = 2$$

50. A bar magnet is released from rest along the axis of a very long vertical copper tube. After some time the magnet will

- (1) Move down with almost constant speed
 (2) Oscillate inside the tube
 (3) Move down with an acceleration greater than g
 (4) Move down with an acceleration equal to g

Official Ans. by NTA (1)

Ans. (1)

Sol. After some time both force becomes equal.

SECTION-B

51. A square loop of side 2.0 cm is placed inside a long solenoid that has 50 turns per centimetre and carries a sinusoidally varying current of amplitude 2.5 A and angular frequency $700\ \text{rad s}^{-1}$. The central axes of the loop and solenoid coincide. The amplitude of the emf induced in the loop is $x \times 10^{-4}\ \text{V}$. The value of x is _____

(Take, $\pi = \frac{22}{7}$)

Official Ans. by NTA (44)

Ans. (44)

Sol.

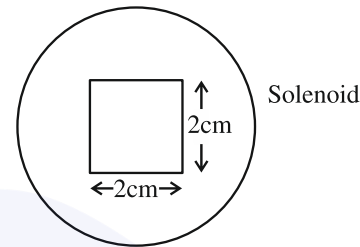

$$B_{\text{due to solenoid}} = \mu_0 n I$$

$$\Phi_{\text{through square}} = \mu_0 n I \times A \quad (A = \text{Area})$$

$$\text{Emf} = \mu_0 n A \times \frac{dI}{dt}$$

$$= \mu_0 n A \times I_0 \omega \cos \omega t$$

$$\text{Emf amplitude} = \mu_0 n A \times I_0 \omega$$

$$= 4\pi \times 10^{-7} \times \frac{50}{10^{-2}} \times 4 \times 10^{-4} \times 2.5 \times 700$$

$$= 44 \times 10^{-4}\ \text{V}$$

52. A rectangular block of mass 5 kg attached to a horizontal spiral spring executes simple harmonic motion of amplitude 1 m and time period 3.14 s. The maximum force exerted by spring on block is _____ N.

Official Ans. by NTA (20)

Ans. (20)

Sol.

$$\therefore T = 3.14 = \pi$$

$$T = \frac{2\pi}{\omega} \Rightarrow \omega = 2$$

$$F_{\text{max}} = m a_{\text{max}}$$

$$= m (A\omega^2)$$

$$= mA (2)^2$$

$$= 5 \times 1 \times 4$$

$$= 20\ \text{N}$$

53. If 917 \AA be the lowest wavelength of Lyman series then the lowest wavelength of Balmer series will be _____ \AA .

Official Ans. by NTA (3668)

Ans. (3668)

Sol. For lowest wavelength of Lyman series

$$\frac{1}{\lambda} = RZ^2 \left[\frac{1}{1^2} - \frac{1}{\infty^2} \right] = RZ^2$$

For lowest wavelength of Balmer series

$$\frac{1}{\lambda'} = RZ^2 \left[\frac{1}{2^2} - \frac{1}{\infty^2} \right] = \frac{RZ^2}{4}$$

$$\lambda' = \frac{4}{RZ^2} = 4 \times 917$$

$$= 3668 \text{ \AA}$$

54. Figure below shows a liquid being pushed out of the tube by a piston having area of cross section 2.0 cm^2 . The area of cross section at the outlet is 10 mm^2 . If the piston is pushed at a speed of 4 cm s^{-1} , the speed of outgoing fluid is _____ cm s^{-1} .

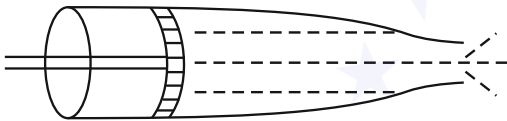

Official Ans. by NTA (80)

Ans. (80)

Sol. By equation of continuity

$$A_1 V_1 = A_2 V_2$$

$$V_2 = \frac{4}{0.2} = 80 \text{ cm/s}$$

55. A straight wire carrying a current of 14 A is bent into a semicircular arc of radius 2.2 cm as shown in the figure. The magnetic field produced by the current at the centre (O) of the arc, is _____ $\times 10^{-4} \text{ T}$

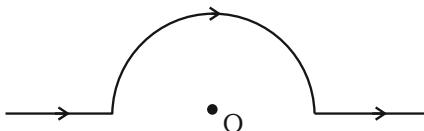

Official Ans. by NTA (2)

Ans. (2)

Sol.
$$B_{\text{at } O} = \frac{\mu_0 I}{4R} = \frac{4\pi \times 10^{-7} \times 14}{4 \times 2.2 \times 10^{-2}}$$

$$= 2 \times 10^{-4} \text{ T}$$

56. A point object, 'O' is placed in front of two thin symmetrical coaxial convex lenses L_1 and L_2 with focal length 24 cm and 9 cm respectively. The distance between two lenses is 10 cm and the object is placed 6 cm away from lens L_1 as shown in the figure. The distance between the object and the image formed by the system of two lenses is _____ cm .

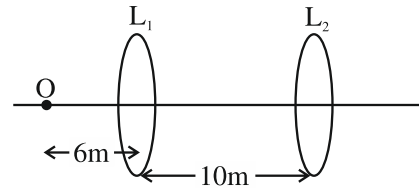

Official Ans. by NTA (34)

Ans. (34)

From Ist lens
$$\frac{1}{v} + \frac{1}{6} = \frac{1}{24}$$

$$\frac{1}{v} = \frac{1}{24} - \frac{1}{6} = -\frac{1}{8}$$

$$v = -8 \text{ cm}$$

From IInd lens
$$\frac{1}{v} + \frac{1}{18} = \frac{1}{9}$$

$$\frac{1}{v} = \frac{1}{18}$$

$$v = 18$$

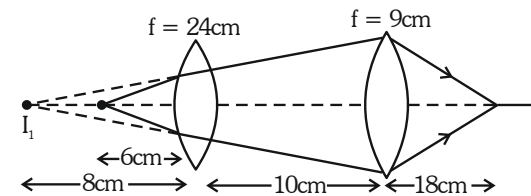

So distance between object and its image
 $= 6 + 10 + 18 = 34 \text{ cm}$

57. A rectangular parallelepiped is measured as $1 \text{ cm} \times 1 \text{ cm} \times 100 \text{ cm}$. If its specific resistance is $3 \times 10^{-7} \Omega \text{ m}$, then the resistance between its two opposite rectangular faces will be _____ $\times 10^{-7} \Omega$.

Official Ans. by NTA (3)

Ans. (3)

Sol.

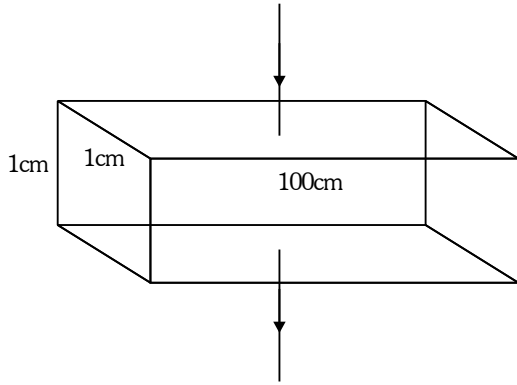

$$R = \rho \frac{\ell}{A} = \frac{3 \times 10^{-7} \times (1 \times 10^{-2})}{100 \times 1 \times 10^{-4}}$$

$$= 3 \times 10^{-7} \Omega$$

58. A force of $-P\hat{k}$ acts on the origin of the coordinate system. The torque about the point $(2, -3)$ is $P(\hat{a}i + \hat{b}j)$, the ratio of $\frac{a}{b}$ is $\frac{x}{2}$. The value of x is

Official Ans. by NTA (3)

Ans. (3)

Sol. $\vec{\tau} = \vec{r} \times \vec{F}$

Where $\vec{r} = -2\hat{i} + 3\hat{j}$

$$\vec{\tau} = (-2\hat{i} + 3\hat{j}) \times (-P\hat{k})$$

$$= P(-2\hat{j} - 3\hat{i}) = P(-3\hat{i} - 2\hat{j})$$

\Rightarrow So $a = -3, b = -2$

$$\frac{a}{b} = \frac{3}{2}$$

59. If the maximum load carried by an elevator is 1400 kg (600 kg – Passenger + 800 kg – elevator), which is moving up with a uniform speed of 3 ms^{-1} and the frictional force acting on it is 2000 N, then the maximum power used by the motor is _____ kW ($g = 10 \text{ m/s}^2$).

Official Ans. by NTA (48)

Ans. (48)

Sol. $P_{\max} = F_{\max} \times v$

$$F_{\max} = 1400 \text{ g} + \text{friction}$$

$$= 14000 + 2000 = 16000$$

$$P_{\max} = 16000 \times 3 = 48000 \text{ W} = 48 \text{ kW}$$

60. An electron revolves around an infinite cylindrical wire having uniform linear charge density $2 \times 10^{-8} \text{ Cm}^{-1}$ in circular path under the influence of attractive electrostatic field as shown in the figure. The velocity of electron with which it is revolving is _____ $\times 10^6 \text{ ms}^{-1}$. Given mass of electron = $9 \times 10^{-31} \text{ kg}$.

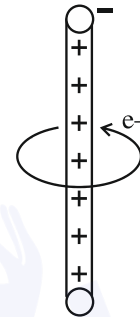

Official Ans. by NTA (8)

Ans. (8)

Sol.

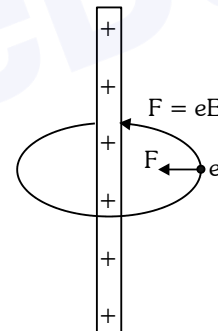

$$eE = \frac{mV^2}{r}$$

$$e \frac{2k\lambda}{r} = \frac{mV^2}{r}$$

$$V = \sqrt{\frac{e \cdot 2k\lambda}{m}}$$

$$= \sqrt{\frac{1.6 \times 10^{-19} \times 2 \times 9 \times 10^9 \times 2 \times 10^{-8}}{9 \times 10^{-31}}}$$

$$= 8 \times 10^6 \text{ m/s}$$