

FINAL JEE–MAIN EXAMINATION – APRIL, 2023

(Held On Monday 10th April, 2023)

TIME : 9 : 00 AM to 12 : 00 NOON

SECTION-A

31. A physical quantity P is given as

$$P = \frac{a^2 b^3}{c \sqrt{d}}$$

The percentage error in the measurement of a, b, c and d are 1%, 2%, 3% and 4% respectively. The percentage error in the measurement of quantity P will be

- (1) 13% (2) 14%
 (3) 12% (4) 16%

Official Ans. by NTA (1)

Ans. (1)

Sol. $\frac{\Delta P}{P} \times 100\% = \left(2 \frac{\Delta a}{a} + 3 \frac{\Delta b}{b} + \frac{\Delta c}{c} + \frac{1}{2} \frac{\Delta d}{d} \right) \times 100\%$

$$= 2(1\%) + 3(2\%) + 3\% + \frac{1}{2} \times 4\% = 13\%$$

32. Assuming the earth to be a sphere of uniform mass density, the weight of a body at a depth $d = \frac{R}{2}$

from the surface of earth, if its weight on the surface of earth is 200 N, will be:

(Given R = Radius of earth)

- (1) 400 N (2) 500 N
 (3) 300 N (4) 100 N

Official Ans. by NTA (4)

Ans. (4)

Sol. $M = \frac{W}{g} = \frac{200}{10} = 20 \text{ kg}$

Acc. due to gravity at a depth $g' = g \left(1 - \frac{d}{R} \right)$

d → depth from surface

$$d = \frac{R}{2}$$

$$g' = g \left(1 - \frac{R/2}{R} \right) = \frac{g}{2} = 5 \text{ m/s}^2$$

weight = m × g

at depth $R/2 = 20 \times 5 = 100 \text{ N}$

33. A zener diode of power rating 1.6 W is to be used as voltage regulator. If the zener diode has a breakdown of 8V and it has to regulate voltage fluctuating between 3V and 10 V. The value of resistance R_s for safe operation of diode will be :

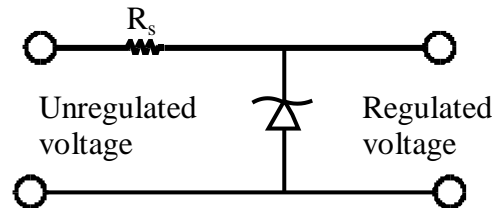

- (1) 13.3Ω (2) 12Ω
 (3) 10Ω (4) 13Ω

Official Ans. by NTA (3)

Ans. (3)

Sol.

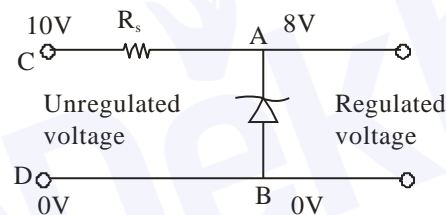

$$V_b = 8 \text{ volt}$$

$$V_A - V_B = 8 \text{ volt}$$

Current through zener diode,

$$i = \frac{P}{V} = \frac{1.6 \text{ W}}{8 \text{ V}} = 0.2 \text{ A}$$

$$V_C - V_A = 10 - 8 \text{ volt}$$

$$\therefore R = \frac{V_C - V_A}{i} = \frac{2 \text{ V}}{0.2 \text{ A}} = 10 \Omega$$

[Note : A zener diode can regulate only if input voltage is \geq zener breakdown voltage the range of input voltage should be 8 to 10 V so that output voltage remains constant = 8 V]

34. The range of the projectile projected at an angle of 15° with horizontal is 50 m. If the projectile is projected with same velocity at an angle of 45° with horizontal, then its range will be :

- (1) 50 m (2) $50\sqrt{2}$ m
 (3) 100 m (4) $100\sqrt{2}$ m

Official Ans. by NTA (3)

Ans. (3)

Sol. $R = \frac{v^2 \sin 2\theta}{g}$

$R \propto \sin(2\theta)$

$\frac{R_1}{R_2} = \frac{\sin(2\theta_1)}{\sin(2\theta_2)} = \frac{\sin(2 \times 15)}{\sin(2 \times 45)} = \frac{\sin 30^\circ}{\sin 90^\circ}$

$\frac{50}{R_2} = \frac{1}{2}$

$R_2 = 100m$

35. A carrier wave of amplitude 15V is modulated by a sinusoidal base band signal of amplitude 3V. The ratio of maximum amplitude to minimum amplitude in an amplitude modulated wave is :

(1) 2 (2) $\frac{3}{2}$

(3) 5 (4) 1

Official Ans. by NTA (2)

Ans. (2)

Sol. Given, $A_c = 15 V$

$A_m = 3V$

Maximum amplitude of modulated wave

$A_{max} = A_c + A_m = 15 + 3 = 18V$

Minimum amplitude of modulated wave

$A_{min} = A_c - A_m = 15 - 3 = 12V$

$\therefore \frac{A_c + A_m}{A_c - A_m} = \frac{18}{12} = \frac{3}{2}$

36. The angular momentum for the electron in Bohr's orbit is L. If the electron is assumed to revolve in second orbit of hydrogen atom, then the change in angular momentum will be :

(1) $\frac{L}{2}$ (2) zero

(3) L (4) 2L

Official Ans. by NTA (3)

Ans. (3)

Sol. $L = mvr$, $r \propto n^2$, $v \propto \frac{1}{n}$

$\therefore L \propto n$

Also, $L = \frac{nh}{2\pi}$, Bohr orbit is, $L_1 = L = \frac{1 \cdot h}{2\pi}$

$L_2 = 2[L] = 2L$

$L_2 = \frac{2h}{2\pi}$

So, change = $L_2 - L_1 = 2L - L = L$

37. A particle of mass m moving with velocity v collides with a stationary particle of mass 2m. After collision, they stick together and continue to move together with velocity

(1) v

(2) $\frac{v}{2}$

(3) $\frac{v}{3}$

(4) $\frac{v}{4}$

Official Ans. by NTA (3)

Ans. (3)

Sol.

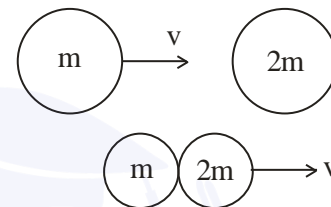

Applying conservation of linear momentum

$\Rightarrow \vec{P}_i = \vec{P}_f$

$mv + 2m \times 0 = (3m)v'$

$\therefore mv = 3mv'$

$v' = \frac{v}{3}$

38. Given below are two statement :

Statement I : If the number of turns in the coil of a moving coil galvanometer is doubled then the current sensitivity becomes double.

Statement II : Increasing current sensitivity of a moving coil galvanometer by only increasing the number of turns in the coil will also increase its voltage sensitivity in the same ratio:

In the light of the above statement, choose the correct answer from the options given below :

(1) Statement I is false but Statement II is true

(2) Both Statement I and Statement II are true

(3) Both Statement I and Statement II are false

(4) Statement I is true but Statement II is false

Official Ans. by NTA (4)

Ans. (4)

Sol. For a moving coil galvanometer

$$BiNA = k\theta$$

$$\theta = \left(\frac{BNA}{k} \right) i ; \text{Current sensitive} = \frac{BNA}{k}$$

So, if N is doubled then current sensitivity is doubled.

Voltage sensitivity

$$B \frac{V}{R} NA = k\theta$$

$$V = \frac{BNA}{Rk} \theta, \text{ as N is doubled R is also doubled.}$$

So, no change in voltage sensitivity.

Hence, option (4) is right.

39. Match List I with List II :

List-I		List II	
(A)	3 Translational degrees of freedom	(I)	Monoatomic gases
(B)	3 Translational, 2 rotational degrees of freedoms	(II)	Polyatomic gases
(C)	3 Translational, 2 rotational and 1 vibrational degrees of freedom	(III)	Rigid diatomic gases
(D)	3 Translational, 3 rotational and more than one vibrational degrees of freedom	(IV)	Nonrigid diatomic gases

Choose the correct answer from the options given below :

- (1) (A) – (IV), (B) – (III), (C) – (II), (D) – (I)
 (2) (A) – (IV), (B) – (II), (C) – (I), (D) – (III)
 (3) (A) – (I), (B) – (III), (C) – (IV), (D) – (II)
 (4) (A) – (I), (B) – (IV), (C) – (III), (D) – (II)

Official Ans. by NTA (3)

Ans. (3)

Sol. Factual

Type of gases	No. of degrees of freedom
Monoatomic gas	3T
Diatomic + rigid	3T + 2R
Diatomic + non-rigid	3T + 2R + 1V
Polyatomic	3T + 3R + More than 1V

T = Translational degree of freedom

R = Rotational degree of freedom

V = Vibrational degree of freedom

40. The equivalent resistance of the circuit shown below between points a and b is :

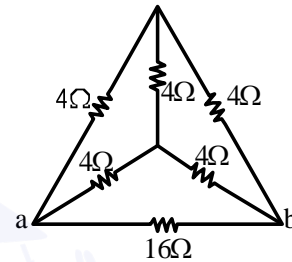

- (1) 24Ω (2) 3.2Ω
 (3) 20Ω (4) 16Ω

Official Ans. by NTA (2)

Ans. (2)

Sol. The circuit can be reduced to

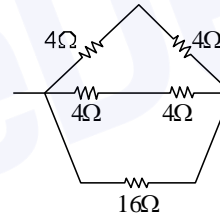

$$\Rightarrow R_{eq} = \frac{16 \times 4}{16 + 4} = \frac{16}{5} \Omega$$

$$= R_{eq} = 3.2 \Omega$$

41. Consider two containers A and B containing monoatomic gases at the same Pressure (P), Volume (V) and Temperature (T). The gas in A is compressed isothermally to $\frac{1}{8}$ of its original volume while the gas B is compressed adiabatically to $\frac{1}{8}$ of its original volume. The ratio of final pressure of gas in B to that of gas in A is :

- (1) 8 (2) $8^{\frac{3}{2}}$
 (3) $\frac{1}{8}$ (4) 4

Official Ans. by NTA (4)

Ans. (4)

Sol. Isothermal process, $T = \text{constant}$

$$PV = nRT = \text{constant}$$

$$P_1V_1 = P_2V_2$$

$$PV = P_A(V/8)$$

$$P_A = 8P$$

Adiabatic process, $PV^\gamma = \text{constant}$

γ for monoatomic gas is $\frac{5}{3}$.

$$P_1V_1^\gamma = P_2V_2^\gamma$$

$$\frac{P_B}{P} = \left(\frac{V_1}{V_2}\right)^\gamma = \left(\frac{V}{V/8}\right)^{\frac{5}{3}}$$

$$P_B = 32P$$

$$\frac{P_B}{P_A} = \frac{32P}{8P} = 4$$

42. Given below are two statements:

Statement I : Maximum power is dissipated in a circuit containing an inductor, a capacitor and a resistor connected in series with an AC source, when resonance occurs

Statement II : Maximum power is dissipated in a circuit containing pure resistor due to zero phase difference between current and voltage.

In the light of the above statements, choose the correct answer from the options given below :

- (1) Statement I is false but Statement II is true
- (2) Statement I is true but Statement II is false
- (3) Both Statement I and Statement II are true
- (4) Both Statement I and Statement II are false

Official Ans. by NTA (3)

Ans. (3)

Sol. Power will be maximum when impedance is minimum

$$Z = [R^2 + (X_L - X_C)^2]^{\frac{1}{2}}$$

At resonance, $X_L = X_C$

$$Z_{\min} = R$$

43. Two satellites of masses m and $3m$ revolve around the earth in circular orbits of radii r & $3r$ respectively. The ratio of orbital speeds of the satellites respectively is :

- (1) 1 : 1
- (2) 3 : 1
- (3) $\sqrt{3}$:1
- (4) 9 : 1

Official Ans. by NTA (3)

Ans. (3)

Sol. $v = \sqrt{\frac{GM}{r}}$

$$v \propto \frac{1}{\sqrt{r}} \Rightarrow \frac{v_1}{v_2} = \sqrt{\frac{r_2}{r_1}} = \sqrt{\frac{3r}{r}}$$

$$= \sqrt{3}:1$$

44. Given below are two statements:

Statement I : Pressure in a reservoir of water is same at all points at the same level of water.

Statement II : The pressure applied to enclosed water is transmitted in all directions equally.

In the light of the above statements, choose the correct answer from the options given below :

- (1) Statement I is false but Statement II is true
- (2) Both Statement I and Statement II are true
- (3) Statement I is true but Statement II is false
- (4) Both Statement I and Statement II are false

Official Ans. by NTA (2)

Ans. (2)

Sol. Pressure in a static liquid will be same at each point on same horizontal level.

$$\therefore P = P_{\text{atm}} + \rho gh$$

As per Pascal law, same pressure applied to enclosed water is transmitted in all directions equally.

45. The equivalent capacitance of the combination shown is

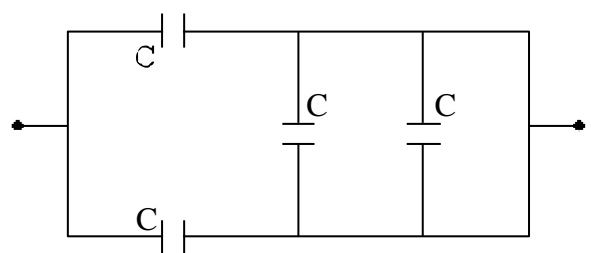

- (1) $\frac{C}{2}$
- (2) $4C$
- (3) $2C$
- (4) $\frac{5}{3}C$

Official Ans. by NTA (3)

Ans. (3)

Sol. The circuit can be reduced to

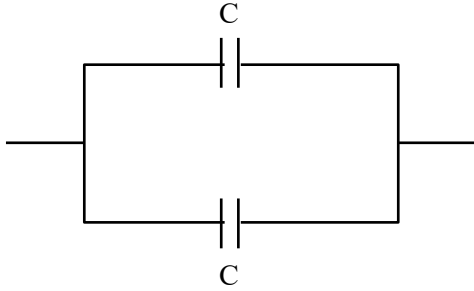

Parallel combination

$$C_{eq} = C + C = 2C$$

46. The energy of an electromagnetic wave contained in a small volume oscillates with

- (1) zero frequency
- (2) half the frequency of the wave
- (3) double the frequency of the wave
- (4) the frequency of the wave

Official Ans. by NTA (3)

Ans. (3)

Sol. $E = E_0 \sin(\omega t - kx)$

$$\text{Energy density} \left(\frac{du}{dv} \right) = \epsilon_0 E_0^2 \sin^2(\omega t - kx)$$

$$\frac{\epsilon_0 E_0^2}{2} [1 - \cos(2\omega t - 2kx)]$$

47. An object is placed at a distance of 12 cm in front of a plane mirror. The virtual and erect image is formed by the mirror. Now the mirror is moved by 4 cm towards the stationary object. The distance by which the position of image would be shifted, will be:

- (1) 4 cm towards mirror
- (2) 8 cm towards mirror
- (3) 8 cm away from mirror
- (4) 2 cm towards mirror

Official Ans. by NTA (2)

Ans. (2)

Sol. Initial

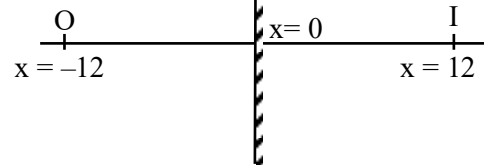

Final

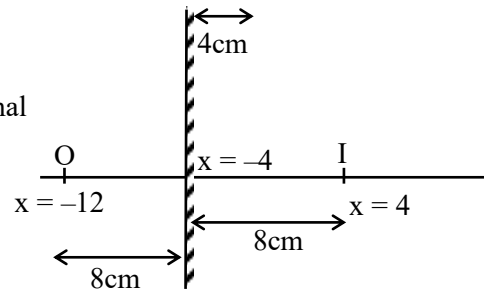

∴ Shifting of image will be 8 cm towards mirror.

48. The de Broglie wavelength of a molecule in a gas at room temperature (300 K) is λ_1 . If the temperature of the gas is increased to 600 K, then the de Broglie wavelength of the same gas molecule becomes

- (1) $\frac{1}{\sqrt{2}}\lambda_1$
- (2) $2\lambda_1$
- (3) $\frac{1}{2}\lambda_1$
- (4) $\sqrt{2}\lambda_1$

Official Ans. by NTA (1)

Ans. (1)

Sol. From K.T.G.

$$v_{RMS} = \sqrt{\frac{3k_B T}{m}}$$

$$v_{RMS} \propto \sqrt{T}$$

$$\text{and } \frac{h}{mv_{RMS}} = \lambda \text{ i.e., } \lambda \propto \frac{1}{\sqrt{T}}$$

$$\frac{\lambda_2}{\lambda_1} = \sqrt{\frac{T_1}{T_2}} = \sqrt{\frac{300}{600}} = \frac{1}{\sqrt{2}}$$

$$\lambda_2 = \frac{\lambda_1}{\sqrt{2}}$$

49. A particle executes S.H.M. of amplitude A along x-axis. At $t = 0$, the position of the particle is $x = \frac{A}{2}$ and it moves along positive x-axis the displacement of particle in time t is $x = A \sin(\omega t + \delta)$, then the value δ will be :

- (1) $\frac{\pi}{6}$ (2) $\frac{\pi}{3}$
 (3) $\frac{\pi}{4}$ (4) $\frac{\pi}{2}$

Official Ans. by NTA (1)

Ans. (1)

Sol. $X = A \sin(\omega t + \delta)$ $V = A \omega \cos(\omega t + \delta)$
 $\frac{A}{2} = A \sin(\omega t + \delta)$ $\therefore V$ is +ve, δ must be
 At $t = 0$ in 1st quadrant or 4th
 $\sin \delta = \frac{1}{2} \Rightarrow \delta = \frac{\pi}{6}, \frac{5\pi}{6}$ quadrant
 \therefore Common solution is $\delta = \frac{\pi}{6}$

50. The position-time graphs for two students A and B returning from the school to their homes are shown in figure :

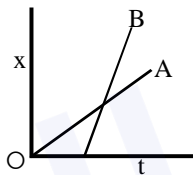

- (A) A lives closer to the school
 (B) B lives closer to the school
 (C) A takes lesser time to reach home
 (D) A travels faster than B
 (E) B travels faster than A

Choose the correct answer from the options given below :

- (1) (A) and (E) only
 (2) (B) and (E) only
 (3) (A), (C) and (E) only
 (4) (A), (C) and (D) only

Official Ans. by NTA (1)

Ans. (1)

Sol. As slope of B > Slope of A
 $\therefore V_B > V_A$
 Also, $t_B < t_A$

SECTION-B

51. Unpolarised light of intensity 32 Wm^{-2} passes through the combination of three polaroids such that the pass axis of the last polaroid is perpendicular to that of the pass axis of first polaroid. If intensity of emerging light is 3 Wm^{-2} , then the angle between pass axis of first two polaroids is _____°.

Official Ans. by NTA (30)

Ans. (30, 60)

Sol. $I_0 = 32 \text{ W / m}^2$

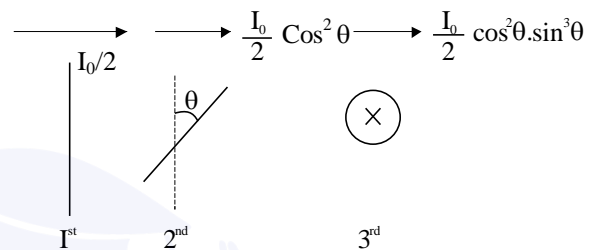

$$I_{\text{net}} = 3 = \frac{32}{2} \cos^2 \theta \cdot \sin^2 \theta$$

$$\frac{3}{4} = 4 \sin^2 \theta \cdot \cos^2 \theta = (\sin 2\theta)^2$$

$$\frac{\sqrt{3}}{2} = \sin(2\theta)$$

Hence, $\theta = 30^\circ$ and 60°

52. A closed circular tube of average radius 15 cm, whose inner walls are rough, is kept in vertical plane. A block of mass 1 kg just fit inside the tube. The speed of block is 22 m/s, when it is introduced at the top of tube. After completing five oscillations, the block stops at the bottom region of tube. The work done by the tube on the block is _____ J. [Given $g = 10 \text{ m/s}^2$]

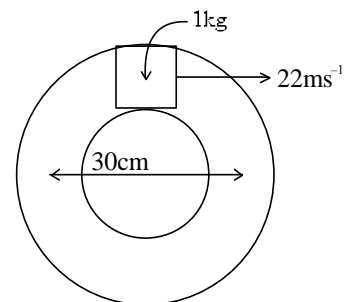

Official Ans. by NTA (+245)

Ans. (-245)

Sol. $r_{avg} = 15 \text{ cm}$

$$w_f + w_g = \Delta KE$$

$$w_f + 10 \times 0.3 = -\frac{1}{2} \times 484$$

$$w_f = -245 \text{ J}$$

53. If the earth suddenly shrinks to $\frac{1}{64}$ th of its original volume with its mass remaining the same, the period of rotation of earth becomes $\frac{24}{x}$ h. The value of x is _____.

Official Ans. by NTA (16)

Ans. (16)

Sol. From conservation of angular momentum

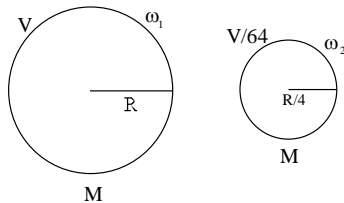

$$\frac{2}{5}MR^2\omega_1 = \frac{2}{5}M\left(\frac{R}{4}\right)^2\omega_2$$

$$\Rightarrow MR^2\omega_1 = \frac{MR^2}{16}\omega_2$$

$$\Rightarrow \frac{\omega_1}{\omega_2} = \frac{1}{16} \Rightarrow \frac{T_2}{T_1} = \frac{1}{16} \Rightarrow \frac{T_1}{T_2} = \frac{16}{1} = \frac{t_1}{x}$$

1 t_2

54. The current required to be passed through a solenoid of 15 cm length and 60 turns in order to demagnetise a bar magnet of magnetic intensity $2.4 \times 10^3 \text{ Am}^{-1}$ is _____ A.

Official Ans. by NTA (6)

Ans. (6)

Sol. $I = H$

Given, $I = 2.4 \times 10^3 \text{ A/m}$

$$2.4 \times 10^3 = H = ni$$

$$n = \frac{N}{\ell}$$

$$2.4 \times 10^3 = \frac{60}{15 \times 10^{-2}} i$$

$$i = \frac{2.4 \times 15 \times 10}{60} = \frac{36}{6} = 6 \text{ A}$$

55. A 1m long metal rod XY completes the circuit as shown in figure. The plane of the circuit is perpendicular to the magnetic field of flux density 0.15 T. If the resistance of the circuit is 5Ω , the force needed to move the rod in direction, as indicated, with a constant speed of 4 m/s will be _____ 10^{-3} N .

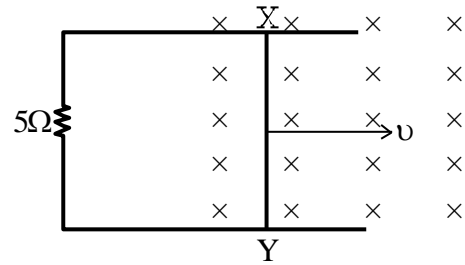

Official Ans. by NTA (18)

Ans. (18)

Sol. $F = i\ell B$

$$= \left(\frac{\varepsilon}{R}\right)\ell B = \left(\frac{vB\ell}{R}\right)\ell B = \frac{vB^2\ell^2}{R} = \frac{4}{5} \times \left(\frac{15}{100}\right)^2 \times 1^2$$

$$= \frac{4}{5} \times \frac{225}{10^4}$$

$$= \frac{180}{10^4} = 0.018 \text{ N}$$

$$= 18 \times 10^{-3} \text{ N}$$

56. A transverse harmonic wave on a string is given by $y(x, t) = 5 \sin(6t + 0.003x)$

where x and y are in cm and t in sec. The wave velocity is _____ ms^{-1} .

Official Ans. by NTA (20)

Ans. (20)

Sol. $y(x, t) = 5 \sin(6t + 0.003x)$

$$k = 0.003 \text{ cm}^{-1}, \quad \omega = 6 \text{ rad/s}, \quad v = \frac{\omega}{k}$$

$$\Rightarrow \frac{6}{0.003 \times 10^2} = 20 \text{ ms}^{-1}$$

57. The decay constant for a radioactive nuclide is $1.5 \times 10^{-5} \text{ s}^{-1}$. Atomic of the substance is 60 g mole⁻¹, ($N_A = 6 \times 10^{23}$). The activity of 1.0 μg of the substance is _____ $\times 10^{10}$ Bq.

Official Ans. by NTA (15)

Ans. (15)

Sol. $\lambda = 1.5 \times 10^{-5} \text{ s}^{-1}$

$$\text{No. of mole} = \frac{1 \times 10^{-6}}{60} = \frac{10^{-7}}{6}$$

No. of atoms = no. of moles $\times N_A$

$$= \frac{10^{-7}}{6} \times 6 \times 10^{23} = 10^{16}$$

$$A = N_0 \lambda e^{-\lambda t}$$

For, $t = 0$, $A = A_0 = N_0 \lambda$

$$= 1.5 \times 10^{-5} \times 10^{16} = 15 \times 10^{10} \text{ Bq.}$$

58. Three concentric spherical metallic shells X, Y and Z of radius a, b and c respectively [$a < b < c$] have surface charge densities $\sigma, -\sigma$ and σ , respectively.

The shells X and Z are at same potential. If the radii of X & Y are 2 cm and 3 cm, respectively.

The radius of shell Z is _____ cm.

Official Ans. by NTA (5)

Ans. (5)

Sol.

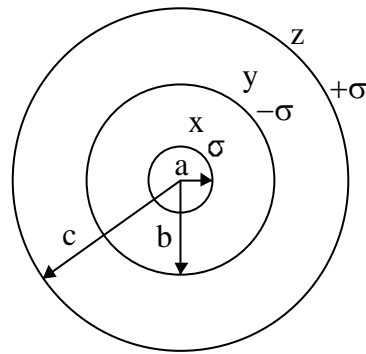

$$q_x = \sigma 4\pi a^2$$

$$q_y = -\sigma 4\pi b^2$$

$$q_z = \sigma 4\pi c^2$$

Potential x = potential z

$$V_x = V_z$$

$$\frac{q_x}{4\pi\epsilon_0 a} + \frac{q_y}{4\pi\epsilon_0 b} + \frac{q_z}{4\pi\epsilon_0 c} = \frac{q_x}{4\pi\epsilon_0 c} + \frac{q_y}{4\pi\epsilon_0 c} + \frac{q_z}{4\pi\epsilon_0 c}$$

$$\frac{\sigma 4\pi a^2}{a} - \frac{\sigma 4\pi b^2}{b} + \frac{\sigma 4\pi c^2}{c} = \frac{4\pi\sigma[a^2 - b^2 + c^2]}{c}$$

$$c(a - b + c) = a^2 - b^2 + c^2$$

$$c(a - b) = a^2 - b^2$$

$$c = a + b$$

$$c = 5 \text{ cm}$$

59. 10 resistors each of resistance 10Ω can be connected in such as to get maximum and minimum equivalent resistance. The ratio of maximum and minimum equivalent resistance will be _____.

Official Ans. by NTA (100)

Ans. (100)

Sol. Maximum resistance occurs

When all the resistors are connected in series combination

$$\therefore R_{\max} = 10 R$$

Here $R = 10 \text{ ohm}$

Minimum resistance occurs

When all the resistance are connected in parallel combination

$$R_{\min} = \frac{R}{10}$$

$$\therefore \frac{R_{\max}}{R_{\min}} = 100$$

60. Two wires each of radius 0.2 cm and negligible mass, one made of steel and other made of brass are loaded as shown in the figure. The elongation of the steel wire is _____ $\times 10^{-6}$ m. [Young's modulus for steel = $2 \times 10^{11} \text{ Nm}^{-2}$ and $g = 10 \text{ ms}^{-2}$]

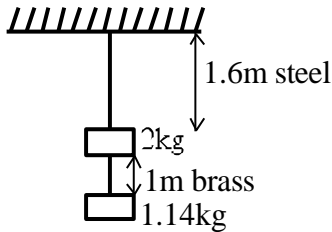

Official Ans. by NTA (20)

Ans. (20)

- Sol. Tension in steel wire $T_2 = 2g + T_1$
 $T_2 = 20 + 11.4$
 $= 31.4 \text{ N}$

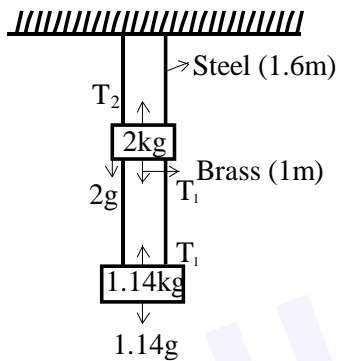

Elongation in steel wire $\Delta L = \frac{T_2 L}{A y}$

$$\Delta L = \frac{31.4 \times 1.6}{\pi (0.2 \times 10^{-2})^2 \times 2 \times 10^{11}}$$

$$\Delta L = \frac{16}{\times 10^{-6} \times 10^{11}}$$

$$= 2 \times 10^{-5} \text{ m}$$

$$= 20 \times 10^{-6} \text{ m}$$