

FINAL JEE–MAIN EXAMINATION – JANUARY, 2023

(Held On Tuesday 24th January, 2023)

TIME : 3 : 00 PM to 6 : 00 PM

SECTION-A

1. The electric potential at the centre of two concentric half rings of radii R_1 and R_2 , having same linear charge density λ is

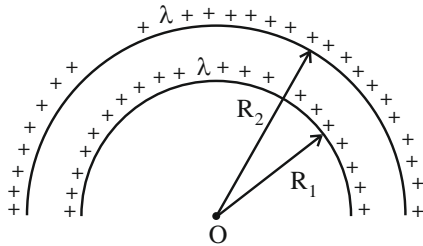

- (1) $\frac{2\lambda}{\epsilon_0}$ (2) $\frac{\lambda}{2\epsilon_0}$
 (3) $\frac{\lambda}{4\epsilon_0}$ (4) $\frac{\lambda}{\epsilon_0}$

Official Ans. by NTA (2)

Ans. (2)

Sol. Potential at centre

$$V = \frac{(\lambda \cdot \pi R_2)}{4\pi\epsilon_0 R_2} + \frac{(\lambda \cdot \pi R_1)}{4\pi\epsilon_0 R_1}$$

$$= \frac{\lambda}{2\epsilon_0}$$

2. Let γ_1 be the ratio of molar specific heat at constant pressure and molar specific heat at constant volume of a monoatomic gas and γ_2 be the similar ratio of diatomic gas. Considering the diatomic gas molecule as a rigid rotator, the ratio, $\frac{\gamma_1}{\gamma_2}$ is

- (1) $\frac{27}{35}$ (2) $\frac{35}{27}$
 (3) $\frac{25}{21}$ (4) $\frac{21}{25}$

Official Ans. by NTA (3)

Ans. (3)

Sol. For monoatomic gas $\gamma_1 = \frac{5}{3}$

For diatomic gas at low temperatures

$$\gamma_2 = \frac{7}{5}$$

$$\therefore \frac{\gamma_1}{\gamma_2} = \frac{\frac{5}{3}}{\frac{7}{5}} = \frac{25}{21}$$

3. An α -particle, a proton and an electron have the same kinetic energy. Which one of the following is correct in case of their De-Broglie wavelength:

- (1) $\lambda_\alpha > \lambda_p > \lambda_e$
 (2) $\lambda_\alpha < \lambda_p < \lambda_e$
 (3) $\lambda_\alpha = \lambda_p = \lambda_e$
 (4) $\lambda_\alpha > \lambda_p < \lambda_e$

Official Ans. by NTA (2)

Ans. (2)

Sol. $\lambda_D = \frac{h}{p} = \frac{h}{\sqrt{2mK}}$

$$\therefore \lambda \propto \frac{1}{\sqrt{m}}$$

$$\therefore m_\alpha > m_p > m_e$$

$$\lambda_e > \lambda_p > \lambda_\alpha$$

4. If the distance of the earth from Sun is 1.5×10^6 km. Then the distance of an imaginary planet from Sun, if its period of revolution is 2.83 years is:

- (1) 6×10^7 km
 (2) 6×10^6 km
 (3) 3×10^6 km
 (4) 3×10^7 km

Official Ans. by NTA (3)

Ans. (3)

Sol. $T^2 \propto R^3 \Rightarrow \left(\frac{T_1}{T_2}\right)^2 = \left(\frac{R_1}{R_2}\right)^3$

$$\Rightarrow \left(\frac{1}{2.83}\right)^2 = \left(\frac{1.5 \times 10^6}{R_2}\right)^3$$

$$\Rightarrow R_2 = \left[(2.83)^2 \times (1.5 \times 10^6)^3\right]^{1/3}$$

$$= 8^{1/3} \times 1.5 \times 10^6 = 3 \times 10^6 \text{ km}$$

5. Match List I with List II

LIST I		LIST II	
A.	AM Broadcast	I.	88-108 MHz
B.	FM Broadcast	II.	540-1600 kHz
C.	Television	III.	3.7-4.2 GHz
D.	Satellite Communication	IV.	54MHz _z - 590MHz

Choose the correct answer from the options given below:

- (1) A-II, B-I, C-IV, D-III
- (2) A-IV, B-III, C-I, D-II
- (3) A-II, B-III, C-I, D-IV
- (4) A-I, B-III, C-II, D-IV

Official Ans. by NTA (1)

Ans. (1)

Sol. AM Broadcast → 540 – 1600 KHz

FM Broadcast → 88 – 108 MHz

Television → 54 – 890 MHz

Satellite communication → 3.7 – 4.2 GHz

∴ A-II, B-I, C-IV, D-III

6. The logic gate equivalent to the given circuit diagram is :

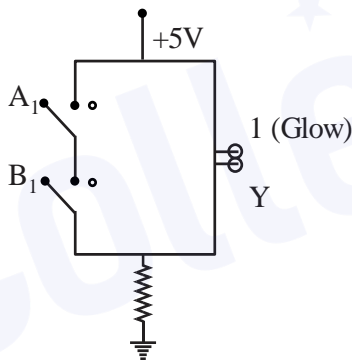

- (1) OR
- (2) NAND
- (3) NOR
- (4) AND

Official Ans. by NTA (2)

Ans. (2)

A ₁	B ₁	Y
0	0	1
0	1	1
1	0	1
1	1	0

Sol.

$$Y = A_1 \odot B_1 \text{ NAND}$$

7. A long solenoid is formed by winding 70 turns cm⁻¹. If 2.0 A current flows, then the magnetic field produced inside the solenoid is _____ (μ₀ = 4π × 10⁻⁷ TmA⁻¹)

- (1) 1232 × 10⁻⁴ T
- (2) 176 × 10⁻⁴ T
- (3) 352 × 10⁻⁴ T
- (4) 88 × 10⁻⁴ T

Official Ans. by NTA (2)

Ans. (2)

Sol. $B = \mu_0 nI$
 $= 4\pi \times 10^{-7} \times 70 \times 10^2 \times 2$
 $= 56\pi \times 10^{-4} \text{ T}$
 $= 176 \times 10^{-4} \text{ T}$

8. Given below are two statements:

Statement I: Acceleration due to earth's gravity decreases as you go 'up' or 'down' from earth's surface.

Statement II: Acceleration due to earth's gravity is same at a height 'h' and depth 'd' from earth's surface, if h = d.

In the light of above statements, choose the **most appropriate** answer form the options given below

- (1) Statement I is incorrect but statement II is correct
- (2) Both Statement I and Statement II are incorrect
- (3) Statement I is correct but statement II is incorrect
- (4) Both Statement I and II are correct

Official Ans. by NTA (3)

Ans. (3)

Sol. $g' = \frac{g}{\left(1 + \frac{h}{R}\right)^2}$

$$g' = g \left\{1 - \frac{d}{R}\right\}$$

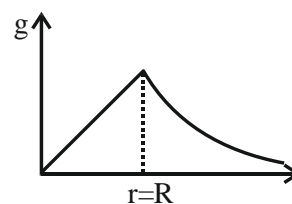

Statement I is correct & Statement II is incorrect

9. A metallic rod of length 'L' is rotated with an angular speed of ' ω ' normal to a uniform magnetic field 'B' about an axis passing through one end of rod as shown in figure. The induced emf will be :

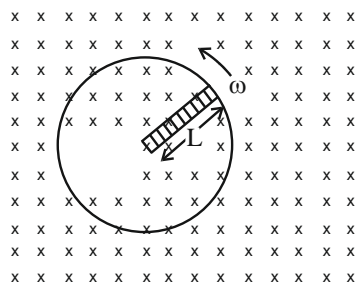

- (1) $\frac{1}{4} B^2 L \omega$
 (2) $\frac{1}{4} B L^2 \omega$
 (3) $\frac{1}{2} B L^2 \omega$
 (4) $\frac{1}{2} B^2 L^2 \omega$

Official Ans. by NTA (3)

Ans. (3)

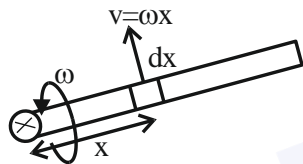

Sol.

$$\int d\varepsilon = \int B(\omega x) dx$$

$$\varepsilon = B\omega \int_0^L x dx = \frac{B\omega L^2}{2}$$

10. When a beam of white light is allowed to pass through convex lens parallel to principal axis, the different colours of light converge at different point on the principle axis after refraction. This is called :

- (1) Scattering
 (2) Chromatic aberration
 (3) Spherical aberration
 (4) Polarisation

Official Ans. by NTA (2)

Ans. (2)

Sol. Based on fact.

11. The frequency (ν) of an oscillating liquid drop may depend upon radius (r) of the drop, density (ρ) of liquid and the surface tension (s) of the liquid as : $\nu = r^a \rho^b s^c$. The values of a, b and c respectively are

- (1) $\left(-\frac{3}{2}, -\frac{1}{2}, \frac{1}{2}\right)$ (2) $\left(\frac{3}{2}, -\frac{1}{2}, \frac{1}{2}\right)$
 (3) $\left(\frac{3}{2}, \frac{1}{2}, -\frac{1}{2}\right)$ (4) $\left(-\frac{3}{2}, \frac{1}{2}, \frac{1}{2}\right)$

Official Ans. by NTA (1)

Ans. (1)

Sol. $[T^{-1}] = [L^1]^a [M^1 L^{-3}]^b \left[\frac{MLT^{-2}}{L}\right]^c$

$$\Rightarrow T^{-1} = M^{b+c} \cdot L^{a-3b} \cdot T^{-2c}$$

$$c = \frac{1}{2}, b = -\frac{1}{2}, a - 3b = 0$$

$$a + \frac{3}{2} = 0 \Rightarrow a = -\frac{3}{2}$$

12. A body of mass 200g is tied to a spring of spring constant 12.5 N/m, while the other end of spring is fixed at point O. If the body moves about O in a circular path on a smooth horizontal surface with constant angular speed 5 rad/s, then the ratio of extension in the spring to its natural length will be :

- (1) 1:2 (2) 1:1
 (3) 2:3 (4) 2:5

Official Ans. by NTA (3)

Ans. (3)

Sol.

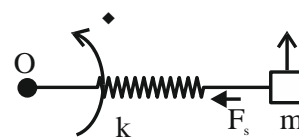

Natural length = L_0

Extension = x

$$kx = m(L_0 + x)\omega^2$$

$$\Rightarrow 12.5x = \frac{1}{5}(L_0 + x)25 \Rightarrow 1.5x = L_0$$

$$\Rightarrow \frac{x}{L_0} = \frac{2}{3}$$

13. A cell of emf 90 V is connected across series combination of two resistors each of 100Ω resistance. A voltmeter of resistance 400Ω is used to measure the potential difference across each resistor. The reading of the voltmeter will be :

- (1) 40 V
- (2) 45 V
- (3) 80 V
- (4) 90 V

Official Ans. by NTA (1)

Ans. (1)

Sol.

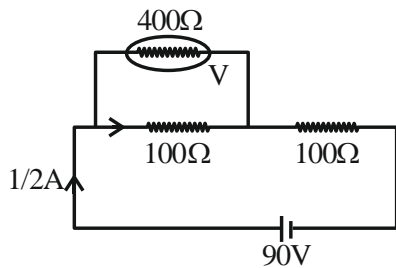

$$R_{eq} = \frac{400 \times 100}{500} + 100$$

$$= 180\Omega$$

$$i = \frac{90}{180} = \frac{1}{2} A$$

$$\text{Reading} = \frac{1}{2} \times \frac{400}{500} \times 100$$

$$= 40 \text{ volt}$$

14. The electric field and magnetic field components of an electromagnetic wave going through vacuum is described by

$$E_x = E_0 \sin(kz - \omega t)$$

$$B_y = B_0 \sin(kz - \omega t)$$

Then the correct relation between E_0 and B_0 is given by

- (1) $kE_0 = \omega B_0$
- (2) $E_0 B_0 = \omega k$
- (3) $\omega E_0 = kB_0$
- (4) $E_0 = kB_0$

Official Ans. by NTA (1)

Ans. (1)

Sol.
$$C = \frac{\omega}{k} = \frac{E_0}{B_0}$$

15. The velocity time graph of a body moving in a straight line is shown in figure.

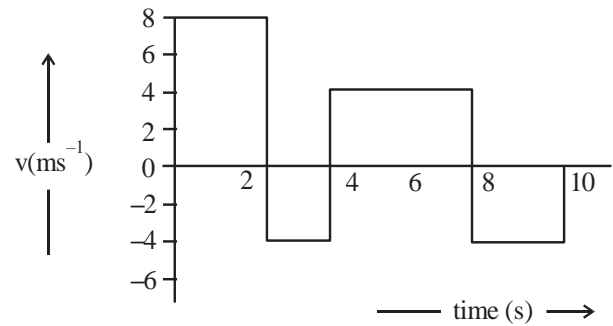

The ratio of displacement to distance travelled by the body in time 0 to 10s is

- (1) 1:1
- (2) 1:4
- (3) 1:2
- (4) 1:3

Official Ans. by NTA (4)

Ans. (4)

Sol. Displacement = $\Sigma \text{area} = 16 - 8 + 16 - 8 = 16 \text{ m}$

$$\text{Distance} = \Sigma |\text{area}| = 48 \text{ m}$$

$$\frac{\text{displacement}}{\text{Distance}} = \frac{1}{3}$$

16. Given below are two statements: one is labelled as **Assertion A** and the other is labelled as **Reason R**
Assertion A: Steel is used in the construction of buildings and bridges.

Reason R: Steel is more elastic and its elastic limit is high.

In the light of above statements, choose the most appropriate answer from the options given below

- (1) Both **A** and **R** are correct but **R** is NOT the correct explanation of **A**
- (2) **A** is not correct but **R** is correct
- (3) Both **A** and **R** are correct and **R** is the correct explanation of **A**
- (4) **A** is correct but **R** is not correct

Official Ans. by NTA (3)

Ans. (3)

Sol. Concept based

17. Given below are two statements: one is labelled as **Assertion A** and the other is labelled as **Reason R**.
Assertion A: A pendulum clock when taken to Mount Everest becomes fast.

Reason R: The value of g (acceleration due to gravity) is less at Mount Everest than its value on the surface of earth.

In the light of the above statements, choose the most appropriate answer from the options given below

- (1) Both **A** and **R** are correct but **R** is **NOT** the correct explanation of **A**
- (2) Both **A** and **R** are correct and **R** is the correct explanation of **A**
- (3) **A** is not correct but **R** is correct
- (4) **A** is correct but **R** is not correct

Official Ans. by NTA (3)

Ans. (3)

Sol. $T \propto \frac{1}{\sqrt{g}}$

18. A photon is emitted in transition from $n = 4$ to $n=1$ level in hydrogen atom. The corresponding wavelength for this transition is

(given, $h = 4 \times 10^{-15}$ eVs) :

- (1) 94.1 nm
- (2) 941 nm
- (3) 97.4 nm
- (4) 99.3 nm

Official Ans. by NTA (1)

Ans. (1)

Sol. $\frac{hc}{\lambda} = \left[1 - \frac{1}{16}\right](13.6 \text{ eV})$

So, $\lambda = 94.1 \text{ nm}$

19. In an Isothermal change, the change in pressure and volume of a gas can be represented for three different temperature; $T_3 > T_2 > T_1$ as :

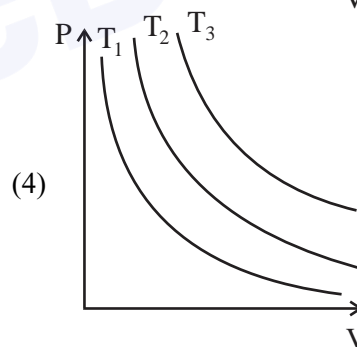
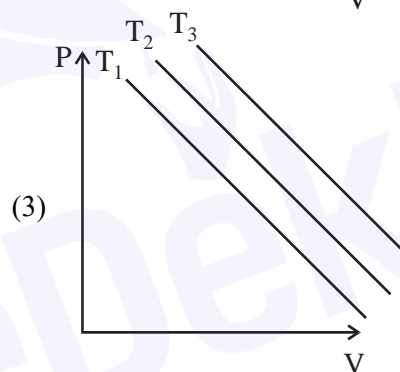
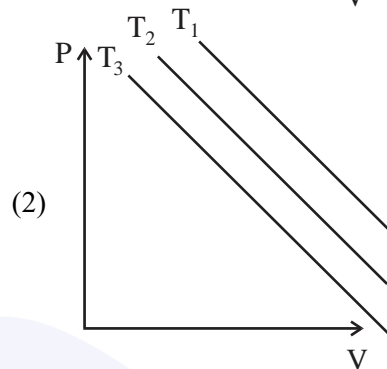
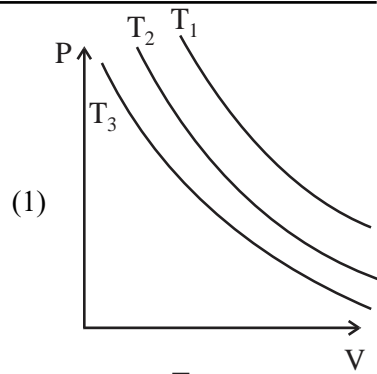

Official Ans. by NTA (4)

Ans. (4)

Sol. For isothermal process P-V graph is rectangular hyperbola

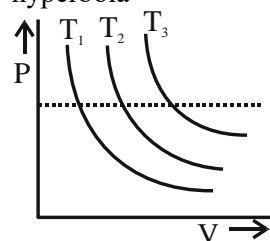

As dotted line is isobaric line which implies $T_3 > T_2 > T_1$ as volume is increasing.

20. If two vectors $\vec{P} = \hat{i} + 2\hat{j} + m\hat{k}$ and $\vec{Q} = 4\hat{i} - 2\hat{j} + m\hat{k}$ are perpendicular to each other.

Then, the value of m will be :

- (1) 1 (2) -1
(3) -3 (4) 2

Official Ans. by NTA (4)

Ans. (4)

Sol. $\vec{P} \cdot \vec{Q} = 0$

$$(\hat{i} + 2m\hat{j} + m\hat{k}) \cdot (4\hat{i} - 2\hat{j} + m\hat{k}) = 0$$

$$\Rightarrow 4 - 4m + m^2 = 0$$

$$\Rightarrow (m - 2)^2 = 0 \Rightarrow m = 2$$

Section-B

21. A uniform solid cylinder with radius R and length L has moment of inertia I_1 , about the axis of cylinder. A concentric solid cylinder of radius $R' = \frac{R}{2}$ and length $L' = \frac{L}{2}$ is caned out of the original cylinder. If I_2 is the moment of inertia of the carved out portion of the cylinder then $\frac{I_1}{I_2} =$ _____

(Both I_1 and I_2 are about the axis of the cylinder)

Official Ans. by NTA (32)

Ans. (32)

Sol.

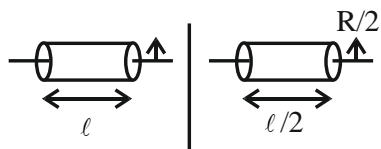

$$I_1 = \frac{m_1 R^2}{2} \quad I_2 = \frac{m_2 (R/2)^2}{2}$$

$$\frac{I_1}{I_2} = \frac{4m_1}{m_2} = \frac{4 \cdot \rho \pi R^2 \ell}{\rho \cdot \frac{\pi R^2}{4} \times \frac{\ell}{2}} \Rightarrow \frac{I_1}{I_2} = 32$$

22. A mass m attached to free end of a spring executes SHM with a period of 1s. If the mass is increased by 3 kg the period of oscillation increases by one second, the value of mass m is _____ kg.

Official Ans. by NTA (1)

Ans. (1)

Sol. $T = 2\pi \sqrt{\frac{m}{k}} = 1$

$$T' = 2\pi \sqrt{\frac{m+3}{k}} = 2$$

$$\frac{T}{T'} = \sqrt{\frac{m}{m+3}} = \frac{1}{2}$$

$$\Rightarrow \frac{m}{m+3} = \frac{1}{4}$$

$$m = 1$$

23. The energy released per fission of nucleus of ^{240}X is 200 MeV. The energy released if all the atoms in 120g of pure ^{240}X undergo fission is _____ $\times 10^{25}$ MeV.

(Given $N_A = 6 \times 10^{23}$)

Official Ans. by NTA (6)

Ans. (6)

Sol. No. of mole = $\frac{120}{240} = \frac{1}{2}$

$$\text{No. of molecules} = \frac{1}{2} \times N_A$$

$$\text{Energy released} = \frac{1}{2} \times 6 \times 10^{23} \times 200$$

$$= 6 \times 10^{25} \text{ MeV}$$

24. A parallel plate capacitor with air between the plate has a capacitance of 15pF. The separation between the plate becomes twice and the space between them is filled with a medium of dielectric constant 3.5. Then the capacitance becomes $\frac{x}{4}$ pF.

The value of x is _____.

Official Ans. by NTA (105)

Ans. (105)

Sol. $C_0 = \frac{\epsilon_0 A}{d} = 15\text{pF}$

$C = \frac{K \epsilon_0 A}{2d} = \frac{3.5}{2} \times 15\text{pF} = \frac{105}{4}\text{pF}$

25. A body of mass 1 kg begins to move under the action of a time dependent force $\vec{F} = (t\hat{i} + 3t^2\hat{j})\text{N}$.

where \hat{i} and \hat{j} are the unit vectors along x and y axis. The power developed by above force, at the time $t = 2\text{s}$. will be _____ W.

Official Ans. by NTA (100)

Ans. (100)

Sol. $\vec{F} = t\hat{i} + 3t^2\hat{j}$

$\frac{m d\vec{v}}{dt} = t\hat{i} + 3t^2\hat{j}$

$m = 1\text{kg}, \int_0^t dv = \int_0^t t dt \hat{i} + \int_0^t 3t^2 dt \hat{j}$

$\vec{v} = \frac{t^2}{2}\hat{i} + t^3\hat{j}$

Power = $\vec{F} \cdot \vec{v} = \frac{t^3}{2} + 3t^5$

At $t = 2$, power = $\frac{8}{2} + 3 \times 32$

= 100

26. If a copper wire is stretched to increase its length by 20%. The percentage increase in resistance of the wire is _____ %.

Official Ans. by NTA (44)

Ans. (44)

Sol. As volume is constant,

So resistance $\propto (\text{length})^2$

\Rightarrow % change in resistance = $20 + 20 + \frac{400}{100} = 44\%$

27. A single turn current loop in the shape of a right angle triangle with sides 5 cm, 12 cm, 13 cm is carrying a current of 2A. The loop is in a uniform magnetic field of magnitude 0.75 T whose direction is parallel to the current in the 13 cm side of the loop. The magnitude of the magnetic force on the 5 cm side will be $\frac{x}{130}$ N. The value of x is _____.

Official Ans. by NTA (9)

Ans. (9)

Sol.

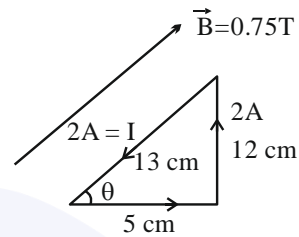

Force on 5 cm side is

$|\vec{F}| = ILB \sin \theta$
 $= (2)(5 \times 10^{-2}) \times \frac{3}{4} \times \frac{12}{13} = \frac{9}{130}\text{N}$

So, $x = 9$

28. Three identical resistors with resistance $R = 12\Omega$ and two identical inductors with self inductance $L = 5\text{mH}$ are connected to an ideal battery with emf of 12 V as shown in figure. The current through the battery long after the switch has been closed will be _____ A.

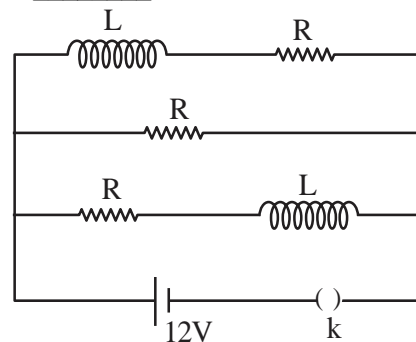

Official Ans. by NTA (3)

Ans. (3)

Sol. After long time an inductor behaves as a resistance-less path.

So current through cell

$I = \frac{12}{R/3} = 3\text{A} \{ \because R = 12\Omega \}$

29. A convex lens of refractive index 1.5 and focal length 18 cm in air is immersed in water. The change in focal length of the lens will be _____ cm.

(Given refractive index of water = $\frac{4}{3}$)

Official Ans. by NTA (54)

Ans. (54)

Sol.

$$\frac{1}{f_{\text{H}_2\text{O}}} = \left(\frac{\mu_g}{\mu_{\text{H}_2\text{O}}} - 1 \right) \left(\frac{2}{R} \right)$$

$$= \frac{1}{8} \left(\frac{2}{R} \right)$$

$$= \frac{1}{(4 f_{\text{air}})}$$

So, $f_{\text{H}_2\text{O}} = 4 f_{\text{air}} = 72 \text{ cm}$

So change in focal length = $72 - 18 = 54 \text{ cm}$

30. A Spherical ball of radius 1mm and density 10.5 g/cc is dropped in glycerine of coefficient of viscosity 9.8 poise and density 1.5 g/cc. Viscous force on the ball when it attains constant velocity is $3696 \times 10^{-x} \text{ N}$. The value of x is

(Given, $g = 9.8 \text{ m/s}^2$ and $\pi = \frac{22}{7}$)

Official Ans. by NTA (7)

Ans. (7)

Sol. When the ball attain terminal velocity

$$F_v = (mg - F_B) \quad (\because a = 0)$$

$$= V\sigma_b g - V\rho_\ell g$$

$$= Vg(\sigma_b - \rho_\ell)$$

$$= \frac{4}{3} \pi (10^{-3})^3 \times 9.8 (10.5 - 1.5) \times 10^3$$

$$= 3696 \times 10^{-7} \text{ N}$$

So, $x = 7$