

FINAL JEE-MAIN EXAMINATION – JANUARY, 2023

(Held On Wednesday 25th January, 2023)

TIME : 9 : 00 AM to 12 : 00 NOON

SECTION-A

1. Electron beam used in an electron microscope, when accelerated by a voltage of 20 kV. has a de-Broglie wavelength of λ_0 . If the voltage is increased to 40 kV. then the de-Broglie wavelength associated with the electron beam would be:

- (1) $3\lambda_0$ (2) $9\lambda_0$
 (3) $\frac{\lambda_0}{2}$ (4) $\frac{\lambda_0}{\sqrt{2}}$

Official Ans. by NTA (4)

Ans. (4)

Sol. When electron is accelerated through potential difference V, then

K.E. = eV

$$\Rightarrow \lambda = \frac{h}{\sqrt{2m(\text{KE})}} = \frac{h}{\sqrt{2meV}}$$

$$\therefore \lambda \propto \frac{1}{\sqrt{V}}$$

$$\therefore \frac{\lambda}{\lambda_0} = \sqrt{\frac{20}{40}}$$

$$\therefore \lambda = \frac{\lambda_0}{\sqrt{2}}$$

2. An object of mass 8 kg is hanging from one end of a uniform rod CD of mass 2 kg and length 1 m pivoted at its end C on a vertical wall as shown in figure. It is supported by a cable AB such that the system is in equilibrium. The tension in the cable is :

(Take $g = 10 \text{ m/s}^2$)

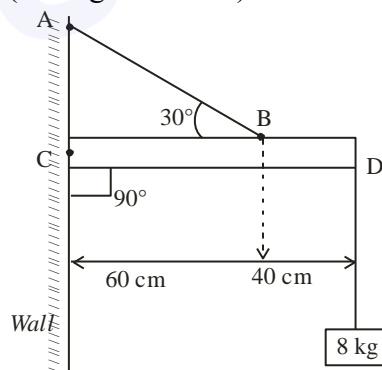

- (1) 240 N (2) 90 N
 (3) 300 N (4) 30 N

Official Ans. by NTA (3)

Ans. (3)

Sol.

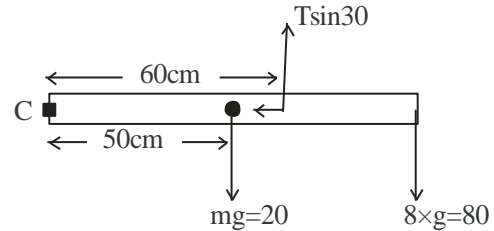

Taking torque about point C

$$\frac{T}{2} \times 60 = 20 \times 50 + 80 \times 100$$

$$\Rightarrow 3T = 100 + 800$$

$$\Rightarrow T = 300 \text{ N}$$

3. A Carnot engine with efficiency 50% takes heat from a source at 600 K. In order to increase the efficiency to 70%, keeping the temperature of sink same, the new temperature of the source will be :

- (1) 360 K (2) 1000 K
 (3) 900 K (4) 300 K

Official Ans. by NTA (2)

Ans. (2)

Sol.

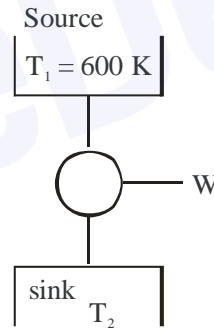

Initially $\eta = \frac{1}{2}$

But $\eta = 1 - \frac{T_2}{T_1}$

$$\therefore \frac{1}{2} = 1 - \frac{T_2}{600}$$

$$\Rightarrow \frac{T_2}{600} = \frac{1}{2} \quad \Rightarrow T_2 = 300 \text{ K}$$

Now efficiency is increased to 70% and $T_2 = 300 \text{ K}$, Let temp of source $T_1 = T$

$$\Rightarrow \frac{7}{10} = 1 - \frac{300}{T}$$

$$\Rightarrow \frac{300}{T} = 1 - \frac{7}{10}$$

$$\Rightarrow \frac{300}{T} = \frac{3}{10} \quad \therefore T = 1000 \text{ K}$$

4. T is the time period of simple pendulum on the earth's surface. Its time period becomes x T when taken to a height R (equal to earth's radius) above the earth's surface. Then, the value of x will be:

- (1) 4 (2) 2
 (3) $\frac{1}{2}$ (4) $\frac{1}{4}$

Official Ans. by NTA (2)

Ans. (2)

Sol. At surface of earth time period

$$T = 2\pi\sqrt{\frac{\ell}{g}}$$

At height h = R

$$= \frac{g}{4}$$

$$\left(1 + \frac{R}{R}\right)$$

$$\therefore xT = 2\pi\sqrt{\frac{\ell}{(g/4)}}$$

$$\Rightarrow xT = 2 \times 2\pi\sqrt{\frac{\ell}{g}}$$

$$\Rightarrow xT = 2T \Rightarrow x = 2$$

5. Assume that the earth is a solid sphere of uniform density and a tunnel is dug along its diameter throughout the earth. It is found that when a particle is released in this tunnel, it executes a simple harmonic motion. The mass of the particle is 100 g. The time period of the motion of the particle will be (approximately) (take $g = 10 \text{ ms}^{-2}$, radius of earth = 6400 km)

- (1) 24 hours
 (2) 1 hour 24 minutes
 (3) 1 hour 40 minutes
 (4) 12 hours

Official Ans. by NTA (2)

Ans. (2)

Sol.

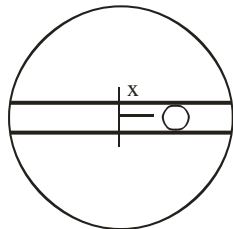

Let at some time particle is at a distance x from centre of Earth, then at that position field

$$E = \frac{GM}{R^3} x$$

\therefore Acceleration of particle

$$\vec{a} = -\frac{GM}{R^3} \vec{x}$$

$$\Rightarrow \omega = \sqrt{\frac{GM}{R^3}} = \sqrt{\frac{g}{R}}$$

$$\text{Now } T = \frac{2\pi}{\omega} = 2\pi\sqrt{\frac{R}{g}}$$

$$\Rightarrow T = 2 \times 3.14 \times \sqrt{\frac{6400 \times 10^3}{10}}$$

$$= 2 \times 3.14 \times 800 \text{ sec} \approx 1 \text{ hour } 24 \text{ minutes}$$

6. A car travels a distance of 'x' with speed V_1 and then same distance 'x' with speed V_2 in the same direction. The average speed of the car is:

- (1) $\frac{v_1 v_2}{2(v_1 + v_2)}$ (2) $\frac{v_1 + v_2}{2}$
 (3) $\frac{2x}{v_1 + v_2}$ (4) $\frac{2v_1 v_2}{v_1 + v_2}$

Official Ans. by NTA (4)

Ans. (4)

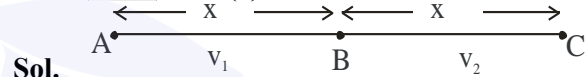

Sol.

$$\text{Average velocity} = \frac{\text{Total displacement}}{\text{Total time}}$$

$$= \frac{x + x}{\frac{x}{v_1} + \frac{x}{v_2}} = \frac{2v_1 v_2}{v_1 + v_2}$$

7. A parallel plate capacitor has plate area 40 cm^2 and plates separation 2 mm. The space between the plates is filled with a dielectric medium of a thickness 1 mm and dielectric constant 5. The capacitance of the system is :

- (1) $24\epsilon_0 F$ (2) $\frac{3}{10}\epsilon_0 F$
 (3) $\frac{10}{3}\epsilon_0 F$ (4) $10\epsilon_0 F$

Official Ans. by NTA (3)

Ans. (3)

Sol.

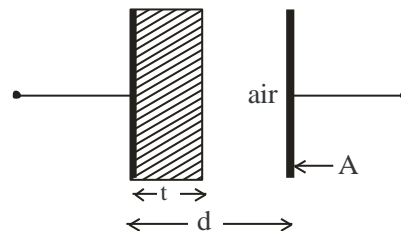

This can be seen as two capacitors in series combination so

$$\frac{1}{C_{\text{eq}}} = \frac{1}{C_1} + \frac{1}{C_2}$$

$$= \frac{1}{\frac{K \epsilon_0 A}{t}} + \frac{1}{\frac{\epsilon_0 A}{d-t}}$$

$$= \frac{t}{K \epsilon_0 A} + \frac{d-t}{\epsilon_0 A}$$

$$= \frac{1 \times 10^{-3}}{5 \epsilon_0 \times 40 \times 10^{-4}} + \frac{1 \times 10^{-3}}{\epsilon_0 40 \times 10^{-4}}$$

$$\frac{1}{C_{eq}} = \frac{1}{20 \epsilon_0} + \frac{1}{4 \epsilon_0}$$

$$C_{eq} = \frac{20 \times 4 \epsilon_0}{24} = \frac{10 \epsilon_0}{3} \text{ F}$$

8. The root mean square velocity of molecules of gas is

- (1) Proportional to square of temperature (T^2).
 (2) Inversely proportional to square root of temperature $\sqrt{\frac{1}{T}}$.

(3) Proportional to square root of temperature \sqrt{T} .

(4) Proportional to temperature (T).

Official Ans. by NTA (3)

Ans. (3)

Sol. The rms speed of a gas molecule is

$$V_{RMS} = \sqrt{\frac{3RT}{M}}$$

$$V_{RMS} \propto \sqrt{T}$$

9. Match List I with List II

| List - I | | List - II | |
|----------|-----------------|-----------|-----------------------------------|
| A | Surface tension | I. | $\text{Kg m}^{-1} \text{ s}^{-1}$ |
| B | Pressure | II. | Kg ms^{-1} |
| C | Viscosity | III. | $\text{Kg m}^{-1} \text{ s}^{-2}$ |
| D | Impulse | IV. | Kg s^{-2} |

Choose the correct answer from the options given below :

- (1) A-IV, B-III, C- II, D- I
 (2) A-IV, B-III, C-I, D-II
 (3) A-III, B-IV, C-I, D-II
 (4) A-II, B-I, C-III, D-IV

Official Ans. by NTA (2)

Ans. (2)

Sol. (A) Surface Tension $= \frac{F}{\ell} = \frac{MLT^{-2}}{L} = ML^{-1} T^{-2}$
 $= \text{Kgs}^{-2} \text{ (IV)}$

(B) Pressure $= \frac{F}{A} = \frac{MLT^{-2}}{L^2}$
 $= \text{kg m}^{-1} \text{ s}^{-2} \text{ (III)}$

(C) Viscosity $= \frac{F}{A \left(\frac{dV}{dz} \right)} = \frac{MLT^{-2}}{L^2 \left(\frac{LT^{-1}}{L} \right)}$
 $L^{-1} T^{-1} = \text{kg m}^{-1} \text{ s}^{-1} \text{ (I)}$

(D) Impulse $= \int F dt = MLT^{-2} \times T$

$$= MLT^{-1} = \text{Kgms}^{-1} \text{ (II)}$$

So A-(IV), B-(III), C-(I), D- (II)

10. In an LC oscillator, if values of inductance and capacitance become twice and eight times, respectively, then the resonant frequency of oscillator becomes x times its initial resonant frequency ω_0 . The value of x is:

- (1) 1/4 (2) 16
 (3) 1/16 (4) 4

Official Ans. by NTA (1)

Ans. (1)

Sol. The resonance frequency of LC oscillations circuit is

$$\omega_0 = \frac{1}{\sqrt{LC}}$$

$$L \rightarrow 2L$$

$$C \rightarrow 8C$$

$$\omega = \frac{1}{\sqrt{2L \times 8C}} = \frac{1}{4\sqrt{LC}}$$

$$\omega = \frac{\omega_0}{4}$$

$$\text{So } x = \frac{1}{4}$$

11. The ratio of the density of oxygen nucleus ($^{16}_8\text{O}$) and helium nucleus (^4_2He) is

- (1) 4:1 (2) 8:1
 (3) 1:1 (4) 2:1

Official Ans. by NTA (3)

Ans. (3)

Sol. Nuclear density is independent of mass number

$$\text{As nuclear density} = \frac{Au}{\frac{4}{3}\pi R^3}$$

$$\text{Also, } R = R_0 A^{\frac{1}{3}}$$

$$\text{And } R^3 = R_0^3 A$$

$$\Rightarrow \text{Nuclear density} = \frac{Au}{\frac{4}{3}\pi R_0^3 A}$$

$$\text{Nuclear density} = \frac{3u}{4\pi R_0^3}$$

\Rightarrow Nuclear density is independent of A

12. A message signal of frequency 5 kHz is used to modulate a carrier signal of frequency 2 MHz. The bandwidth for amplitude modulation is:

- (1) 5 kHz (2) 20 kHz
 (3) 10 kHz (4) 2.5 kHz

Official Ans. by NTA (3)

Ans. (3)

Sol. Given
 Signal frequency $f_m = 5\text{kHz}$
 Carrier wave frequency $f_c = 2\text{MHz}$
 $f_c = 2000\text{KHz}$
 The resultant signal will have band width of frequency given by
 $[(f_c + f_m) - (f_c - f_m)]$
 $\Rightarrow [(2000 + 5) - (2000 - 5)]\text{kHz}$
 $\Rightarrow 10\text{ kHz}$

13. All electromagnetic wave is transporting energy in the negative z direction. At a certain point and certain time the direction of electric field of the wave is along positive y direction. What will be the direction of the magnetic field of the wave at that point and instant?
 (1) Positive direction of x
 (2) Positive direction of z
 (3) Negative direction of x
 (4) Negative direction of y

Official Ans. by NTA (1)

Ans. (1)

Sol. As, poynting vector

$$\vec{S} = \vec{E} \times \vec{H}$$

Given energy transport = negative z direction

Electric field = positive y direction

$$(-\hat{k}) = (+\hat{j}) \times [\hat{i}]$$

Hence according to vector cross product magnetic field should be positive x direction.

14. In Young's double slits experiment, the position of 5th bright fringe from the central maximum is 5 cm. The distance between slits and screen is 1 m and wavelength of used monochromatic light is 600 nm. The separation between the slits is:

- (1) 60 μm (2) 48 μm
 (3) 12 μm (4) 36 μm

Official Ans. by NTA (1)

Ans. (1)

Sol. Given

$$D = 1\text{m}$$

$$\lambda = 600 \times 10^{-9}\text{m}$$

$$n = 5$$

$$\text{As } y_{\text{nth}} = \frac{n\lambda D}{d}$$

$$\Rightarrow \frac{5 \times 600 \times 10^{-9} \times 1}{d} = 5 \times 10^{-2}$$

$$\Rightarrow d = \frac{5 \times 600 \times 10^{-9} \times 1}{5 \times 10^{-2}} = 60 \times 10^{-6}\text{m}$$

$$\Rightarrow d = 60\ \mu\text{m}$$

15. Math List I with List II

| | List – I (Current configuration) | | List – II (Magnetic field at point O) |
|---|-------------------------------------|------|--|
| A | | I. | $B_0 = \frac{\mu_0 I}{4\pi r} [\pi + 2]$ |
| B | | II. | $B_0 = \frac{\mu_0 I}{4 r}$ |
| C | | III. | $B_0 = \frac{\mu_0 I}{2\pi r} [\pi - 1]$ |
| D | | IV. | $B_0 = \frac{\mu_0 I}{4\pi r} [\pi + 1]$ |

Choose the correct answer from the option given below:

- (1) A-III, B-IV, C-I, D-II
 (2) A-I, B-III, C-IV, D-II
 (3) A-III, B-I, C-IV, D-II
 (4) A-II, B-I, C-IV, D-III

Official Ans. by NTA (3)

Ans. (3)

Sol.

(A)

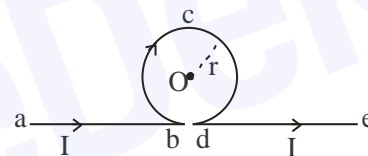

$$B_{ab} = \frac{\mu_0 I}{4\pi r} \text{ (out of the plane)}$$

$$B_{bcd} = \frac{\mu_0 I}{4\pi r} (2\pi) \text{ (in the plane)}$$

$$B_{de} = \frac{\mu_0 I}{4\pi r} \text{ (out of the plane)}$$

Hence magnetic field at O is

$$B_0 = -\frac{\mu_0 I}{4\pi r} + \frac{\mu_0 I}{4\pi r} (2\pi) - \frac{\mu_0 I}{4\pi r}$$

$$B_0 = \frac{\mu_0 I}{2\pi r} (\pi - 1) \dots \dots \dots \text{(III)}$$

(B)

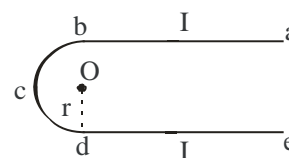

$$B_{ab} = \frac{\mu_0 I}{4\pi r} \text{ (out of the plane)}$$

$$B_{bcd} = \frac{\mu_0 I}{4\pi r} (\pi) \text{ (out of the plane)}$$

$$B_{de} = \frac{\mu_0 I}{4\pi r} \text{ (out of the plane)}$$

Hence magnetic field at O is

$$B_0 = \frac{\mu_0 I}{4\pi r} + \frac{\mu_0 I}{4\pi r}(\pi) + \frac{\mu_0 I}{4\pi r}$$

$$B_0 = \frac{\mu_0 I}{4\pi r}(\pi + 2) \dots \text{(I)}$$

(C)

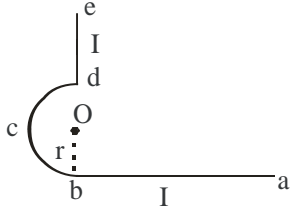

$$B_{ab} = \frac{\mu_0 I}{4\pi r} \text{ (in the plane)}$$

$$B_{bcd} = \frac{\mu_0 I}{4\pi r}(\pi) \text{ (in the plane)}$$

$$B_{de} = 0 \text{ (at the axis)}$$

Hence magnetic field at O is

$$B_0 = \frac{\mu_0 I}{4\pi r}(1 + \pi) \dots \text{(IV)}$$

(D)

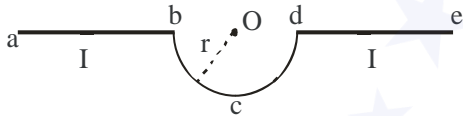

$$B_{ab} = 0 \text{ (at the axis)}$$

$$B_{bcd} = \frac{\mu_0 I}{4\pi r}(\pi) \text{ (out of the plane)}$$

$$B_{de} = 0 \text{ (at the axis)}$$

Hence magnetic field at O is

$$B_0 = \frac{\mu_0 I}{4r} \dots \text{(II)}$$

16. Given below are two statements : one is labeled as Assertion A and the other is labeled as Reason R

Assertion A: Photodiodes are used in forward bias usually for measuring the light intensity.

Reason R: For a p-n junction diode, at applied voltage V the current in the forward bias is more than the current in the reverse bias for $|V_z| > \pm V \geq |V_0|$ where V_0 is the threshold voltage and V_z is the breakdown voltage.

In the light of the above statements, choose the **correct** answer from the options given below

- (1) Both A and R are true and R is correct explanation A
- (2) Both A and R are true but R is NOT the correct explanation A
- (3) A is false but R is true
- (4) A is true but R is false

Official Ans. by NTA (3)

Ans. (3)

Sol. Theory based

Photodiodes are operated in reverse bias condition. For P-N junction current in forward bias (for $V \geq V_0$) is always greater than current in reverse bias (for $V \leq V_z$).

Hence Assertion is false but Reason is true

17. A solenoid of 1200 turns is wound uniformly in a single layer on a glass tube 2 m long and 0.2 m in diameter. The magnetic intensity at the center of the solenoid when a current of 2 A flows through it is:

- (1) $2.4 \times 10^3 \text{ A m}^{-1}$
- (2) $1.2 \times 10^3 \text{ A m}^{-1}$
- (3) 1 A m^{-1}
- (4) $2.4 \times 10^{-3} \text{ A m}^{-1}$

Official Ans. by NTA (2)

Ans. (2)

Sol. Magnetic field at centre inside the solenoid is given by

$$B = \mu_0 nI$$

So magnetic intensity at centre

$$H = \frac{B}{\mu_0} = nI = \left(\frac{1200}{2}\right)(2)$$

$$H = 1.2 \times 10^3 \text{ Am}^{-1}$$

18. A uniform metallic wire carries a current 2 A, when 3.4 V battery is connected across it. The mass of uniform metallic wire is $8.92 \times 10^{-3} \text{ kg}$, density is $8.92 \times 10^3 \text{ kg/m}^3$ and resistivity is $1.7 \times 10^{-8} \Omega\text{-m}$. The length of wire is :

- (1) $l = 6.8 \text{ m}$
- (2) $l = 10 \text{ m}$
- (3) $l = 5 \text{ m}$
- (4) $l = 100 \text{ m}$

Official Ans. by NTA (2)

Ans. (2)

Sol. $I = 2 \text{ A}$

$$\Delta V = 3.4 \text{ V}$$

Using Ohm's Law

$$R = \frac{3.4}{2} = 1.7 \Omega$$

$$1.7 = \frac{\rho L}{A}$$

$$L = \frac{1.7(A)}{\rho}$$

$$M = (\text{density volume})$$

$$\text{Volume} = \frac{8.92 \times 10^{-3}}{8.92 \times 10^3} = 10^{-6}$$

$$L^2 = \frac{1.7}{\rho} (10^{-6}) = \frac{1.7}{1.7} \times 10^2$$

$$L = 10\text{m}$$

19. A bowl filled with very hot soup cools from 98°C to 86°C in 2 minutes when the room temperature is 22°C . How long it will take to cool from 75°C to 69°C ?

- (1) 2 minutes (2) 1.4 minutes
(3) 0.5 minute (4) 1 minute

Official Ans. by NTA (2)

Ans. (2)

Sol. $\frac{\Delta Q}{\Delta t} = -K(T - T_0)$

$$\frac{\Delta Q}{\Delta t} = -K(T_{\text{avg}} - T_0)$$

$$(i) \frac{ms \times 12}{2} = -K \left(\frac{98 + 86}{2} - 22 \right)$$

$$6 = -\frac{K}{ms} \left[\frac{98 + 86}{2} - 22 \right]$$

$$6 = -\frac{K}{ms} [70] \dots\dots\dots(i)$$

$$(ii) \frac{ms \times 6}{\Delta t} = -K \left(\frac{75 + 69}{2} - 22 \right)$$

$$\frac{6}{\Delta t} = -\frac{K}{ms} (50) \dots\dots\dots(ii)$$

$$(ii) \div (i)$$

$$\frac{6}{\Delta t(6)} = \frac{50}{70}$$

$$\Delta t = \frac{7}{5} = 1.4 \text{ min}$$

20. A car is moving with a constant speed of 20 m/s in a circular horizontal track of radius 40 m. A bob is suspended from the roof of the car by a massless string. The angle made by the string with the vertical will be : (Take $g = 10 \text{ m/s}^2$)

- (1) $\frac{\pi}{6}$ (2) $\frac{\pi}{2}$
(3) $\frac{\pi}{4}$ (4) $\frac{\pi}{3}$

Official Ans. by NTA (3)

Ans. (3)

Sol.

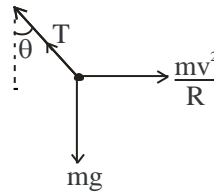

$$T \cos \theta = mg$$

$$T \sin \theta = \frac{mv^2}{R}$$

$$\tan \theta = \frac{v^2}{Rg}$$

$$\tan \theta = \frac{20^2}{40 \times 10}$$

$$\tan \theta = 1$$

$$\Rightarrow \theta = \frac{\pi}{4}$$

SECTION-B

21. A ray of light is incident from air on a glass plate having thickness $\sqrt{3} \text{ cm}$ and refractive index $\sqrt{2}$. The angle of incidence of a ray is equal to the critical angle for glass-air interface. The lateral displacement of the ray when it passes through the plate is $___ \times 10^{-2} \text{ cm}$. (given $\sin 15^\circ = 0.26$)

Official Ans. by NTA (52)

Ans. (52)

Sol.

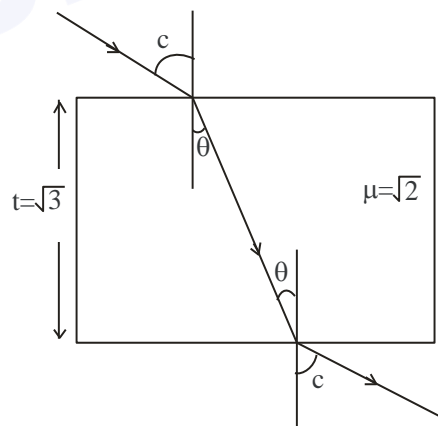

$$\sin c = \frac{1}{\sqrt{2}}$$

$$c = 45^\circ$$

$$\sin c = \mu \sin \theta$$

$$\frac{1}{\sqrt{2}} = \sqrt{2} \sin \theta$$

$$\theta = 30^\circ$$

Lateral displacement:

$$x = t \sin(i - r) \sec r$$

$$x = \sqrt{3} \sin(45^\circ - 30^\circ) \sec 30^\circ$$

$$x = \sqrt{3} (0.26) \left(\frac{2}{\sqrt{3}} \right)$$

$$X = 0.52 \text{ cm}$$

$$x = 52 \times 10^{-2} \text{ cm}$$

22. In the given circuit, the equivalent resistance between the terminal A and B is _____ Ω .

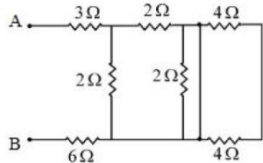

Official Ans. by NTA (10.00)

Ans. (10)

Sol.

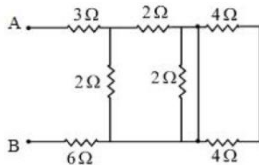

Both 4Ω resistance gets short.

Remove the resistors that have no current.

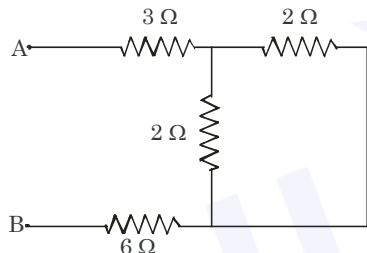

$$R_{eq} = 3 + (2 \parallel 2) + 6$$

$$R_{eq} = 3 + 1 + 6$$

$$R_{eq} = 10 \Omega$$

23. As shown in the figure, in an experiment to determine Young's modulus of a wire, the extension-load curve is plotted. The curve is a straight line passing through the origin and makes an angle of 45° with the load axis. The length of wire is 62.8 cm and its diameter is 4 mm. The Young's modulus is found to be $x \times 10^4 \text{ Nm}^{-2}$.

The value of x is _____.

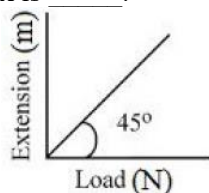

Official Ans. by NTA (5)

Ans. (5)

Sol.

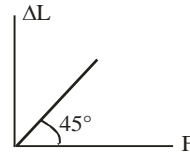

From graph :

$$F = \Delta L$$

$$Y = \frac{FL}{A\Delta L}$$

$$Y = \frac{L}{A}$$

$$Y = \frac{62.8 \times 10^{-2}}{\pi (2 \times 10^{-3})^2}$$

$$Y = 5 \times 10^4 \text{ N/m}^2$$

24. An object of mass 'm' initially at rest on a smooth horizontal plane starts moving under the action of force $F = 2\text{N}$. In the process of its linear motion, the angle θ (as shown in figure) between the direction of force and horizontal varies as $\theta = kx$, where k is a constant and x is the distance covered by the object from its initial position. The expression of kinetic energy of the object will be $E = \frac{n}{k} \sin \theta$. The value of n is _____.

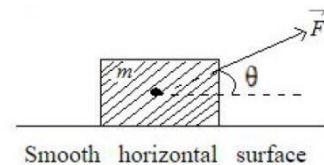

Official Ans. by NTA (2)

Ans. (2)

Sol.

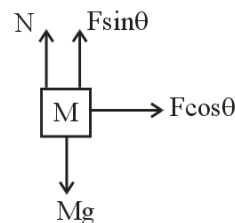

$$F \cos \theta = ma$$

$$2 \cos(kx) = \frac{mvdv}{dx}$$

$$\int_0^v v dv = 2 \int_0^x \cos(kx) dx$$

$$\frac{mv^2}{2} = \frac{2}{k} \sin kx$$

$$\text{K.E.} = \frac{2}{k} \sin \theta$$

$$n = 2$$

25. The wavelength of the radiation emitted is λ_0 when an electron jumps from the second excited state to the first excited state of hydrogen atom. If the electron jumps from the third excited state to the second orbit of the hydrogen atom, the wavelength of the radiation emitted will be $\frac{20}{x} \lambda_0$. The value of x is _____.

Official Ans. by NTA (27)

_____ Ans. (27)

- Sol. _____ n = 4
 _____ n = 3
 _____ n = 2
 _____ n = 1

Second excited state \rightarrow first excited state

$$n = 3 \rightarrow n = 2$$

$$\frac{hc}{\lambda_0} = 13.6 \left(\frac{1}{2^2} - \frac{1}{3^2} \right) \dots\dots(i)$$

Third excited state \rightarrow second orbit

$$n = 4 \rightarrow n = 2$$

$$\frac{hc}{(20\lambda_0/x)} = 13.6 \left(\frac{1}{2^2} - \frac{1}{4^2} \right) \dots\dots(ii)$$

(ii) \div (i)

$$\frac{x}{20} = \frac{\frac{1}{2^2} - \frac{1}{4^2}}{\frac{1}{2^2} - \frac{1}{3^2}}$$

$$x = 27$$

26. I_{CM} is moment of inertia of a circular disc about an axis (CM) passing through its center and perpendicular to the plane of disc. I_{AB} is it's moment of inertia about an axis AB perpendicular to plane and parallel to axis CM at a distance $\frac{2}{3}R$ from center. Where R is the radius of the disc. The ratio of I_{AB} and I_{CM} is x: 9. The value of x is _____.

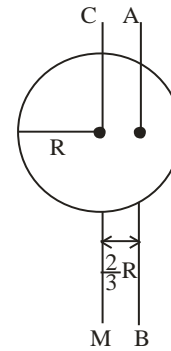

Official Ans. by NTA (17)

_____ Ans. (17)

Sol. $I_{cm} = \frac{mR^2}{2}$

$$I_{AB} = \frac{mR^2}{2} + m \left(\frac{2R}{3} \right)^2 = \frac{17}{18} mR^2$$

$$\frac{I_{AB}}{I_{cm}} = \frac{17}{9} \Rightarrow x = 17$$

27. The distance between two consecutive points with phase difference of 60° in a wave of frequency 500 Hz is 6.0 m. The velocity with which wave is traveling is _____ km/s

Official Ans. by NTA (18)

_____ Ans. (18)

Sol. $\Delta\phi = \frac{2\pi}{\lambda} \Delta x$

$$\frac{\pi}{3} = \frac{2\pi}{\lambda} (6m)$$

$$\Rightarrow \lambda = 36m$$

$$V = f\lambda = (500\text{Hz})(36m)$$

$$= 18000 \text{ m/s} = 18 \text{ km/s}$$

28. A uniform electric field of 10 N/C is created between two parallel charged plates (as shown in figure). An electron enters the field symmetrically between the plates with a kinetic energy 0.5 eV. The length of each plate is 10 cm. The angle (θ) of deviation of the path of electron as it comes out of the field is _____ (in degree).

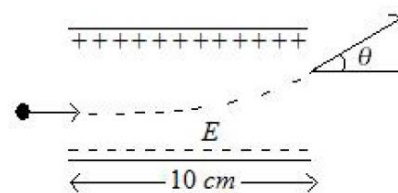

Official Ans. by NTA (45)

Ans. (45)

Sol. $0.5e = \frac{1}{2}mv_x^2 \Rightarrow v_x = \sqrt{\frac{e}{m}}$

Along x $L = v_x t = \sqrt{\frac{e}{m}}t$

Along y $v_y = \frac{eE}{m}t$

dividing $\frac{v_y}{L} = E\sqrt{\frac{e}{m}} = Ev_x$

$\Rightarrow \tan\theta = \frac{v_y}{v_x} = E \times L = 10 \times 0.1 = 1$

$\theta = 45^\circ$

- 29.** An LCR series circuit of capacitance 62.5 nF and resistance of 50 Ω . is connected to an A.C. source of frequency 2.0 kHz. For maximum value of amplitude of current in circuit, the value of inductance is _____ mH.

(take $\pi^2 = 10$)

Official Ans. by NTA (100)

Ans. (100)

Sol. $f = \frac{1}{2\pi\sqrt{LC}}$

$2000\text{Hz} = \frac{1}{2\pi\sqrt{L \times 62.5 \times 10^{-9}}}$

$L = \frac{1}{4\pi^2 \times 2000^2 \times 62.5 \times 10^{-9}} = 0.1\text{H} = 100\text{mH}$

- 30.** If $\vec{P} = 3\hat{i} + \sqrt{3}\hat{j} + 2\hat{k}$ and $\vec{Q} = 4\hat{i} + \sqrt{3}\hat{j} + 2.5\hat{k}$ then, The unit vector in the direction of $\vec{P} \times \vec{Q}$ is

$\frac{1}{x}(\sqrt{3}\hat{i} + \hat{j} - 2\sqrt{3}\hat{k})$. The value of x is

Official Ans. by NTA (4)

Ans. (4)

Sol. $\vec{P} \times \vec{Q} = \begin{vmatrix} \hat{i} & \hat{j} & \hat{k} \\ \sqrt{3} & 2 & 2 \\ \sqrt{3} & 2.5 & 2 \end{vmatrix} = \sqrt{3}\frac{\hat{i}}{2} + \frac{\hat{j}}{2} - \sqrt{3}\hat{k}$

$\Rightarrow \frac{\vec{P} \times \vec{Q}}{|\vec{P} \times \vec{Q}|} = \frac{1}{2}(\sqrt{3}\frac{\hat{i}}{2} + \frac{\hat{j}}{2} - \sqrt{3}\hat{k})$

$= \frac{1}{4}(\sqrt{3}\hat{i} + \hat{j} - 2\sqrt{3}\hat{k}) \quad x = 4$