

FINAL JEE-MAIN EXAMINATION – JUNE, 2022

(Held On Sunday 26th June, 2022)

TIME : 9 : 00 AM to 12 : 00 PM

PHYSICS

TEST PAPER WITH SOLUTION

SECTION-A

1. An expression for a dimensionless quantity P is given by $P = \frac{\alpha}{\beta} \log_e \left(\frac{kt}{\beta x} \right)$; where α and β are constants, x is distance ; k is Boltzmann constant and t is the temperature. Then the dimensions of α will be :

- (A) $[M^0L^{-1}T^0]$ (B) $[ML^0T^{-2}]$
 (C) $[MLT^{-2}]$ (D) $[ML^2T^{-2}]$

Official Ans. by NTA (C)

Ans. (C)

Sol. $P = \frac{\alpha}{\beta} \log_e \left(\frac{kt}{\beta x} \right)$

$$\frac{kt}{\beta x} = 1 \Rightarrow \beta = \frac{kt}{x} = \frac{ML^2T^{-2}}{L}$$

$$\left(\because E = \frac{1}{2} kt \right)$$

As P is dimensionless

$$\Rightarrow [\alpha] = [\beta] = [MLT^{-2}]$$

2. A person is standing in an elevator. In which situation, he experiences weight loss ?

- (A) When the elevator moves upward with constant acceleration
 (B) When the elevator moves downward with constant acceleration
 (C) When the elevator moves upward with uniform velocity
 (D) When the elevator moves downward with uniform velocity

Official Ans. by NTA (B)

Ans. (B)

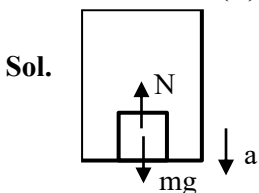

$$mg - N = ma$$

$$\Rightarrow N = m(g - a)$$

\therefore Person experiences weightloss, when

3. An object is thrown vertically upwards. At its maximum height, which of the following quantity becomes zero ?

- (A) Momentum (B) Potential energy
 (C) Acceleration (D) Force

Official Ans. by NTA (A)

Ans. (A)

Sol. At maximum height, $V = 0$

\therefore Momentum of object is zero.

4. A ball is released from rest from point P of a smooth semi-spherical vessel as shown in figure. The ratio of the centripetal force and normal reaction on the ball at point Q is A while angular position of point Q is α with respect to point P. Which of the following graphs represent the correct relation between A and α when ball goes from Q to R ?

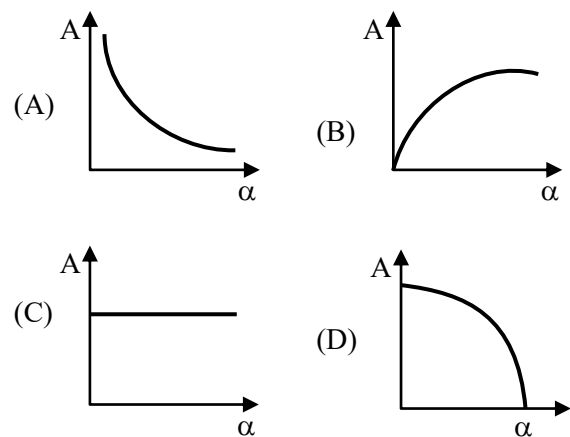
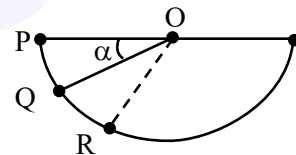

Official Ans. by NTA (C)

Ans. (C)

Sol. $V = \sqrt{2gR \sin \alpha}$

$$N - mg \sin \alpha = \frac{mv^2}{R} = 2mg \sin \alpha$$

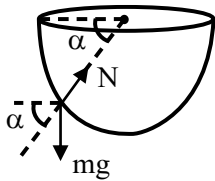

$$\frac{N}{2mg \sin \alpha} = \frac{1}{2} + 1 = \frac{3}{2}$$

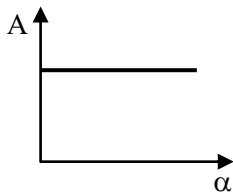

$\Rightarrow A = \text{constant}$

5. A thin circular ring of mass M and radius R is rotating with a constant angular velocity 2 rads^{-1} in a horizontal plane about an axis vertical to its plane and passing through the center of the ring. If two objects each of mass m be attached gently to the opposite ends of a diameter of ring, the ring will then rotate with an angular velocity (in rads^{-1}).

- (A) $\frac{M}{(M+m)}$ (B) $\frac{(M+2m)}{2M}$
 (C) $\frac{2M}{(M+2m)}$ (D) $\frac{2(M+2m)}{M}$

Official Ans. by NTA (C)

Ans. (C)

- Sol. Applying conservation of angular momentum

$$MR^2\omega = (MR^2 + 2mR^2)\omega'$$

$$\omega' = \frac{2M}{M+2m}$$

6. The variation of acceleration due to gravity (g) with distance (r) from the center of the earth is correctly represented by : (Given $R =$ radius of earth)

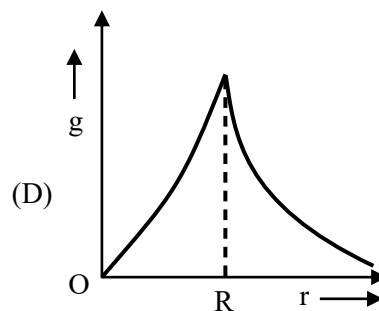
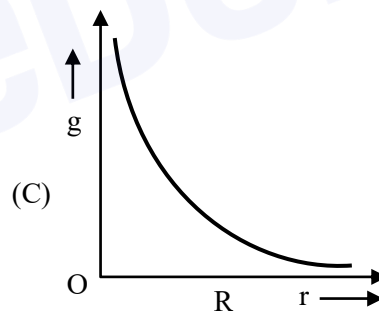
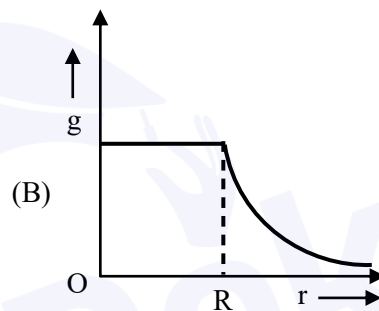
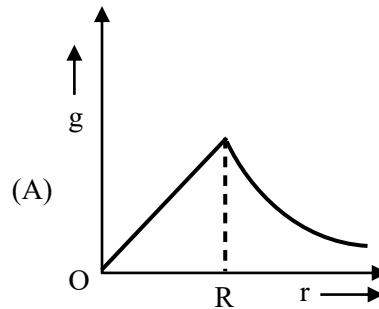

Official Ans. by NTA (A)

Ans. (A)

Sol. $g = \begin{cases} \frac{GMr}{R^3}, r \leq R \\ \frac{GM}{r^2}, r \geq R \end{cases}$

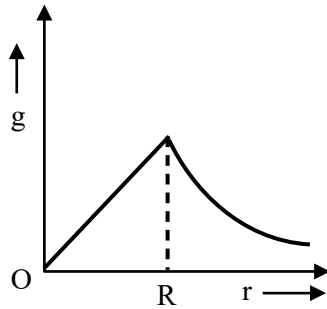

7. The efficiency of a Carnot's engine, working between steam point and ice point, will be :

- (A) 26.81% (B) 37.81%
 (C) 47.81% (D) 57.81%

Official Ans. by NTA (A)

Ans. (A)

Sol. $\eta = \left[1 - \frac{T_L}{T_n} \right] \times 100\%$

$T_L = 0^\circ\text{C} = 273\text{K}, T_n = 373\text{K}$

$\therefore \eta = 26.809\%$

8. Time period of a simple pendulum in a stationary lift is 'T'. If the lift accelerates with $\frac{g}{6}$ vertically

upwards then the time period will be :

(where g = acceleration due to gravity)

- (A) $\sqrt{\frac{6}{5}}T$ (B) $\sqrt{\frac{5}{6}}T$
 (C) $\sqrt{\frac{6}{7}}T$ (D) $\sqrt{\frac{7}{6}}T$

Official Ans. by NTA (C)

Ans. (C)

Sol. $T = 2\pi\sqrt{\frac{\ell}{g_{\text{eff}}}}$

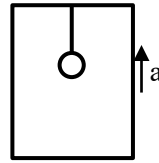

(a) when $a = 0, T = 2\pi\sqrt{\frac{\ell}{g}}$

(b) when $a = \frac{g}{6}, T' = 2\pi\sqrt{\frac{\ell}{g + \frac{g}{6}}}$

$\therefore T' = \sqrt{\frac{6}{7}}T$

9. A thermally insulated vessel contains an ideal gas of molecular mass M and ratio of specific heats 1.4. Vessel is moving with speed v and is suddenly brought to rest. Assuming no heat is lost to the surrounding and vessel temperature of the gas increases by : (R = universal gas constant)

- (A) $\frac{Mv^2}{7R}$
 (B) $\frac{Mv^2}{5R}$
 (C) $2\frac{Mv^2}{7R}$
 (D) $7\frac{Mv^2}{5R}$

Official Ans. by NTA (B)

Ans. (B)

Sol. $\frac{C_p}{C_v} = 1 + \frac{2}{F} = 1.4 \Rightarrow F = 5$

By conservation of energy

$\frac{F}{2} nR\Delta T = \frac{1}{2} [nm] v^2$

$\Delta T = \frac{mv^2}{FR} = \frac{Mv^2}{5R}$

10. Two capacitors having capacitance C_1 and C_2 respectively are connected as shown in figure. Initially, capacitor C_1 is charged to a potential difference V volt by a battery. The battery is then removed and the charged capacitor C_1 is now connected to uncharged capacitor C_2 by closing the switch S . The amount of charge on the capacitor C_2 , after equilibrium is :

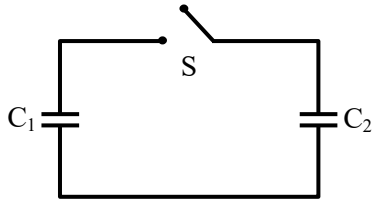

- (A) $\frac{C_1 C_2}{(C_1 + C_2)} V$ (B) $\frac{(C_1 + C_2)}{C_1 C_2} V$
 (C) $(C_1 + C_2)V$ (D) $(C_1 - C_2)V$

Official Ans. by NTA (A)

Ans. (A)

- Sol.** Charge on capacitor C_2

$$= \frac{C_2 \times Q_{\text{total}}}{C_{\text{total}}} = \frac{C_2 [C_1 V]}{C_1 + C_2} = \frac{C_1 C_2 V}{C_1 + C_2}$$

11. **Assertion (A)** : Non-polar materials do not have permanent dipole moment.

Reason (R) : When a non-polar material is placed in an electric field, the centre of the positive charge distribution of its individual atom or molecule coincides with the centre of the negative charge distribution.

In the light of above statements, choose the most appropriate answer from the options given below.

- (A) Both (A) and (R) are correct and (R) is the correct explanation of (A).
 (B) Both (A) and (R) are correct and (R) is not the correct explanation of (A).
 (C) (A) is correct but (R) is not correct.
 (D) (A) is not correct but (R) is correct.

Official Ans. by NTA (C)

- Sol. S1** : In nonpolar molecules, centre of +ve charge coincides with centre of -ve charge, hence net dipole moment is zero.

S2 : When non polar material is placed in external field, centre of charges does not coincide, hence give non zero moment in field

12. The magnetic flux through a coil perpendicular to its plane is varying according to the relation $\phi = (5t^3 + 4t + 2t - 5)$ Weber. If the resistance of the coil is 5 ohm, then the induced current through the coil at $t = 2$ sec will be:

- (A) 15.6 A (B) 16.6 A
 (C) 17.6 A (D) 18.6 A

Official Ans. by NTA (A)

Ans. (A)

- Sol.** $\phi = 5t^3 + 4t^2 + 2t - 5$

$$|e| = \frac{d\phi}{dt} = 15t^2 + 8t + 2$$

$$\text{At } t = 2, |e| = 15 \times 2^2 + 8 \times 2 + 2$$

$$\Rightarrow e = 78V \Rightarrow I = \frac{e}{R} = \frac{78}{5} = 15.60$$

13. An aluminium wire is stretched to make its length, 04% larger. Then percentage change in resistance is:

- (A) 0.4 % (B) 0.2 %
 (C) 0.8 % (D) 0.6 %

Official Ans. by NTA (C)

Ans. (C)

- Sol.** $R = \frac{\rho \ell}{A}$

$$\frac{\Delta R}{R} = \frac{\Delta \ell}{\ell} - \frac{\Delta A}{A}$$

$$\ell A = k$$

$$\frac{\Delta \ell}{\ell} + \frac{\Delta A}{A} = 0$$

$$\frac{\Delta R}{R} = \frac{2\Delta \ell}{\ell}$$

$$\frac{\Delta R}{R} = 2 \times 0.4 = 0.8$$

14. A proton and an alpha particle of the same enter in a uniform magnetic field which is acting perpendicular to their direction of motion. The ratio of the circular paths described by the alpha particle and proton is:

- (A) 1 : 4 (B) 4 : 1
(C) 2 : 1 (D) 1 : 2

Official Ans. by NTA (C)

Ans. (C)

Sol. $\frac{R_\alpha}{R_p} = \frac{M_\alpha}{M_p} \times \frac{q_p}{q_\alpha}$

$$\frac{R_\alpha}{R_p} = \frac{4}{1} \times \frac{1}{2} = 2$$

15. If electric field intensity of a uniform plane electromagnetic wave is given as

$$E = -301.6 \sin(kz - \omega t) \hat{a}_x + 452.4 \sin(kz - \omega t) \hat{a}_y \frac{V}{m}$$

Then, magnetic intensity H of this wave in Am^{-1} will be:

[Given: Speed of light in vacuum $c = 3 \times 10^8 \text{ ms}^{-1}$, permeability of vacuum $\mu_0 = 4\pi \times 10^{-7} \text{ NA}^{-2}$]

- (A) $+0.8 \sin(kz - \omega t) \hat{a}_y + 0.8 \sin(kz - \omega t) \hat{a}_x$
(B) $+1.0 \times 10^{-6} \sin(kz - \omega t) \hat{a}_y + 1.5 \times 10^{-6} \sin(kz - \omega t) \hat{a}_x$
(C) $-0.8 \sin(kz - \omega t) \hat{a}_y - 1.2 \sin(kz - \omega t) \hat{a}_x$
(D) $-1.0 \times 10^{-6} \sin(kz - \omega t) \hat{a}_y - 1.5 \times 10^{-6} \sin(kz - \omega t) \hat{a}_x$

Official Ans. by NTA (C)

Ans. (C)

Sol. $\vec{E} = 301.6 \sin(kz - \omega t) (-\hat{a}_x) + 452.4 \sin(kz - \omega t) \hat{a}_y$
 $\vec{B} = \frac{301.6}{c} \sin(kz - \omega t) (-\hat{a}_y)$

$$+ \frac{452.4}{c} \sin(kz - \omega t) (-\hat{a}_x)$$

$$\vec{H} = \frac{\vec{B}}{\mu_0} = \frac{301.6}{\mu_0 c} \sin(kz - \omega t) (-\hat{a}_y)$$

$$+ \frac{452.4}{\mu_0 c} \sin(kz - \omega t) (-\hat{a}_x)$$

$$\vec{H} = -0.8 \sin(kz - \omega t) \hat{a}_y - 1.2 \sin(kz - \omega t) \hat{a}_x$$

For direction

$\vec{E} \times \vec{B}$ is direction of \vec{C}

For first part $\hat{E} = -\hat{i}, \hat{B} = ?$

$$\hat{E} \times \hat{B} = \hat{k} \Rightarrow \hat{B} = -\hat{j}$$

Similarly for second

$$\hat{E} = \hat{j}, \hat{B} = ?$$

$$\hat{E} \times \hat{B} = \hat{k} \Rightarrow \hat{B} = -\hat{i}$$

16. In free space, an electromagnetic wave of 3 GHz of 3 GHz frequency strikes over the edge of an object of size $\frac{\lambda}{100}$, where λ is the wavelength of the wave in free space. The phenomenon, which happens there will be:

- (A) Reflection (B) Refraction
(C) Diffraction (D) Scattering

Official Ans. by NTA (D)

Ans. (D)

Sol. $\frac{a}{\lambda} = \frac{1}{100}$

For reflection size of obstacle must be much larger than wavelength, for diffraction size should be order of wavelength.

Since the object is of size $\frac{\lambda}{100}$, much smaller than

17. An electron with speed v and a photon with speed c have the same de-Broglie wavelength. If the kinetic energy and momentum of electron are E_e and p_e and that of photon are E_{ph} and p_{ph} respectively. Which of the following is correct?

- (A) $\frac{E_e}{E_{ph}} = \frac{2c}{v}$ (B) $\frac{E_e}{E_{ph}} = \frac{v}{2c}$
 (C) $\frac{p_e}{p_{ph}} = \frac{2c}{v}$ (D) $\frac{p_e}{p_{ph}} = \frac{v}{2c}$

Official Ans. by NTA (B)

Ans. (B)

Sol. $\lambda_e = \lambda_{\text{photon}}$

$$\frac{h}{mv} = \frac{h}{P_{\text{photon}}} \Rightarrow P_{\text{photon}} = mv$$

$$\frac{E_e}{E_{ph}} = \frac{\frac{1}{2}mv^2}{\frac{hc}{\lambda}} = \frac{1}{2} \frac{mv}{P_{ph}} \times v = \frac{v}{2c}$$

18. How many alpha and beta particles are emitted when Uranium ${}_{92}\text{U}^{238}$ decays to lead ${}_{82}\text{Pb}^{206}$?

- (A) 3 alpha particles and 5 beta particles
 (B) 6 alpha particles and 4 beta particles
 (C) 4 alpha particles and 5 beta particles
 (D) 8 alpha particles and 6 beta particles

Official Ans. by NTA (D)

Ans. (D)

Sol. ${}_{92}^{238}\text{U} \rightarrow [8]_2^4\text{He} + [6]_{-1}^0\text{e} + {}_{82}^{206}\text{Pb}$

8 α particles and 6 β particles are emitted.

19. The I-V characteristics of a p-n junction diode in forward bias is shown in the figure. The ratio of dynamic resistance, corresponding to forward bias voltages of 2V and 4V respectively, is :

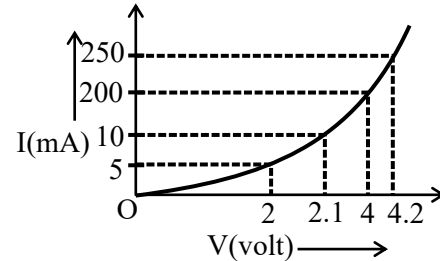

- (A) 1 : 2 (B) 5 : 1
 (C) 1 : 40 (D) 20 : 1

Official Ans. by NTA (B)

Ans. (B)

Sol. $R = \frac{\Delta V}{\Delta i}$

$$\frac{R_1}{R_2} = \frac{\Delta V_1}{\Delta V_2} \frac{\Delta i_2}{\Delta i_1} = \frac{0.1}{0.2} \times \frac{50}{5} = 5$$

20. Choose the correct statement for amplitude modulation:

- (A) Amplitude of modulating is varied in accordance with the information signal.
 (B) Amplitude of modulated is varied in accordance with the information signal.
 (C) Amplitude of carrier signal is varied in accordance with the information signal.
 (D) Amplitude of modulated is varied in accordance with the modulating signal.

Official Ans. by NTA (C)

Ans. (C)

Sol. In amplitude modulation the amplitude of high frequency carrier wave is varied in accordance with message signal

SECTION-B

1. A fighter jet is flying horizontally at a certain altitude with a speed of 200 ms^{-1} . When it passes directly overhead an anti-aircraft gun, bullet is fired from the gun, at an angle θ with the horizontal, to hit the jet. If the bullet speed is 400 m/s , the value of θ will be $^\circ$.

Official Ans. by NTA (60)

Ans. (60)

- Sol. Both should have same horizontal component of velocity

$$200 = 400 \cos \theta$$

$$\theta = 60^\circ$$

2. A ball of mass 0.5 kg is dropped from the height of 10 m . The height, at which the magnitude of velocity becomes equal to the magnitude of acceleration due to gravity, is m . (Use $g = 10 \text{ m/s}^2$).

Official Ans. by NTA (5)

Ans. (5)

- Sol. $v^2 = u^2 + 2as$

$$100 = 0 + 2(10)s$$

$$S = 5 \text{ m}$$

$$\text{Height from ground} = 10 - 5 = 5 \text{ m}$$

3. The elastic behaviour of material for linear stress and linear strain, is shown in the figure. The energy density for a linear strain of 5×10^{-4} is kJ/m^3 . Assume that material is elastic upto the linear strain of 5×10^{-4} .

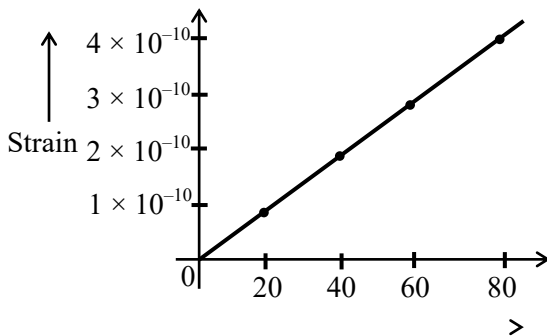

Official Ans. by NTA (25)

Sol. $y = \frac{\text{stress}}{\text{strain}} = 2.0 \times 10^{10}$

$$\text{Energy density} = \frac{1}{2} \text{stress} \times \text{strain}$$

$$= \frac{1}{2} (\text{strain})^2 y = \frac{1}{2} (5 \times 10^{-4})^2 \times 20 \times 10^{10}$$

$$= 25 \times 10^2 \times 10 = 25 \frac{\text{kJ}}{\text{m}^3}$$

Ans. 25

4. The elongation of a wire on the surface of the earth is 10^{-4} m . The same wire of same dimensions is elongated by $6 \times 10^{-5} \text{ m}$ on another planet. The acceleration due to gravity on the planet will be ms^{-2} . (Take acceleration due to gravity on the surface of earth = 10 m/s^2)

Official Ans. by NTA (6)

Ans. (6)

- Sol. $\Delta l \propto g$

$$\frac{\Delta l_{\text{earth}}}{\Delta l_{\text{planet}}} = \frac{g_{\text{earth}}}{g_{\text{planet}}} = \frac{10^{-4}}{6 \times 10^{-5}}$$

$$g_{\text{planet}} = 6 \text{ m/s}^2$$

Ans. 6.00

5. A 10Ω , 20 mH coil carrying constant current is connected to a battery of 20 V through a switch is opened current becomes zero in $100\mu\text{s}$. The average emf induced in the coil is V .

Official Ans. by NTA (400)

Ans. (400)

Sol. $\langle \epsilon \rangle = \frac{\int \epsilon dt}{\int dt} = \frac{\int (L di / dt) dt}{\int dt} = \frac{L \int di}{\int dt}$

$$\langle \epsilon \rangle = \frac{L \Delta i}{\Delta t}$$

$$i_0 = \frac{V}{R} = \frac{20}{10} = 2 \text{ A}, \text{ if } i = 0 \text{ A}$$

$$T = 100 \mu\text{s}, L = 20 \text{ mH}$$

$$\langle \epsilon \rangle = \frac{20 \times 10^{-3} \times (2 - 0)}{100 \times 10^{-6}}$$

$$= \frac{2 \times 10^3}{5}$$

$$\langle \epsilon \rangle = 400 \text{ V}$$

6. A light ray is incident, at an incident angle θ_1 , on the system of two plane mirrors M_1 and M_2 having an inclination angle 75° between them (as shown in figure). After reflecting from mirror M_1 it gets reflected back by the mirror M_2 with an angle of reflection 30° . The total deviation of the ray will be degree.

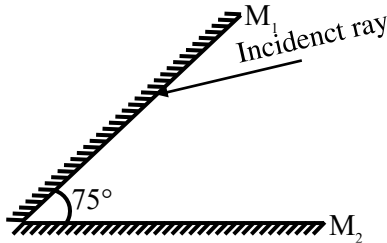

Official Ans. by NTA (210)

Ans. (210)

Sol. $\delta_{\text{total}} = 360^\circ - 2\theta$

$= 360^\circ - 2 \times 75^\circ$

$\delta_{\text{total}} = 210^\circ$

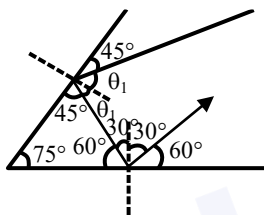

$\theta_1 = 45^\circ$

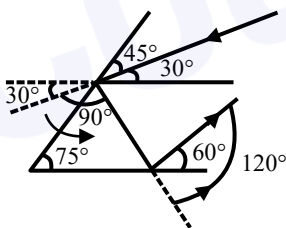

$\delta = 120^\circ + 90^\circ = 210^\circ$

7. In a vernier callipers, each cm on the main scale is divided into 20 equal parts. If tenth vernier scale division coincides with ninth main scale division. Then the value of vernier constant will be $\times 10^{-2}$ mm.

Official Ans. by NTA (5)

Sol. $20 \text{ MSD} = 1 \text{ cm}$

$1 \text{ MSD} = \frac{1}{20} \text{ cm}$

$10 \text{ VSD} = 9 \text{ MSD}$

$1 \text{ VSD} = \frac{9}{10} \text{ MSD}$

$= \frac{9}{10} \times \frac{1}{20} \text{ cm}$

$1 \text{ VSD} = \frac{9}{200} \text{ cm}$

$VC = 1 \text{ MSD} - 1 \text{ VSD}$

$= \frac{1}{20} \text{ cm} - \frac{9}{200} \text{ cm}$

$= \frac{1}{200} \times 10 \text{ mm}$

$VC = 5 \times 10^{-2} \text{ mm}$

Ans. 5

8. As per the given circuit, the value of current through the battery will be A.

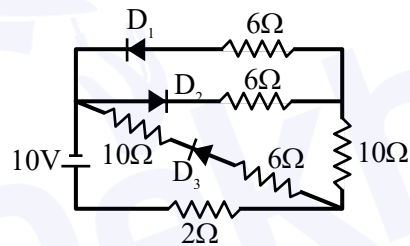

Official Ans. by NTA (1)

Ans. (1)

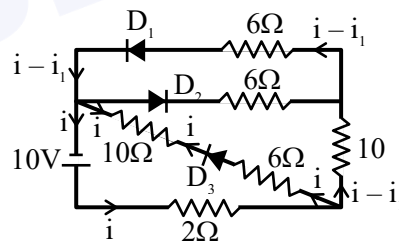

Sol.

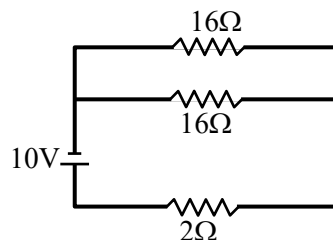

$V = IR_{\text{net}}$

$10 = I \times 10$

$I = 1 \text{ A}$

Ans. 1

9. A 110 V , 50 Hz, AC source is connected in the circuit (as shown in figure). The current through the resistance 55Ω , at resonance in the circuit, will be A.

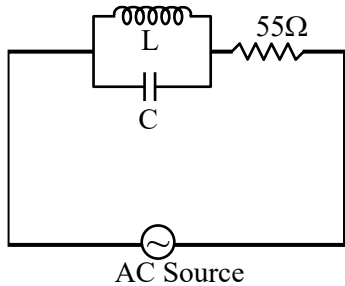

Official Ans. by NTA (0)

Ans. (0)

Sol. At resonance $I_L = I_C$

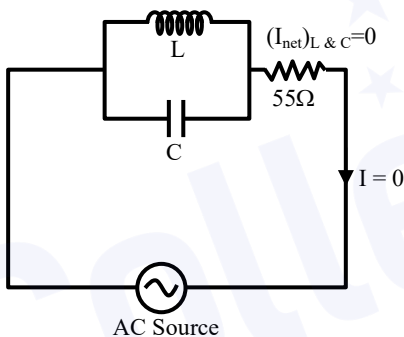

Alternatively,

$$\frac{1}{Z} = \sqrt{\left(\frac{1}{X_L} - \frac{1}{X_C}\right)^2}$$

At resonance, $X_L = X_C$ & $Z \rightarrow \infty$

$\therefore Z_{\text{total circuit}} \rightarrow \infty$ i.e, $I = 0$

Ans. 0

10. An ideal fluid of density 800 kgm^{-3} , flows smoothly through a bent pipe (as shown in figure) that tapers in cross-sectional area from a to $\frac{a}{2}$. The pressure difference between the wide and narrow sections of pipe is 4100 Pa . At wider section, the velocity of fluid is $\frac{\sqrt{x}}{6} \text{ ms}^{-1}$ for $x = \dots\dots\dots$
(Given $g = 10 \text{ m}^{-2}$)

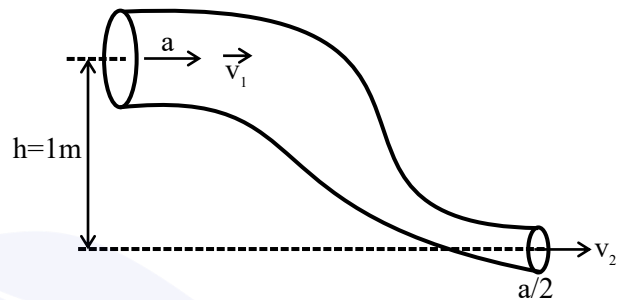

Official Ans. by NTA (363)

Ans. (363)

Sol. From continuity equation

$$av_1 = \frac{a}{2}v_2$$

$$v_2 = 2v_1$$

From Bernoulli's theorem,

$$P_1 + \rho gh_1 + \frac{1}{2}\rho v_1^2 = P_2 + \rho gh_2 + \frac{1}{2}\rho v_2^2$$

$$P_1 - P_2 = \rho \left[\left(\frac{v_2^2 - v_1^2}{2} \right) + g(h_2 - h_1) \right]$$

$$4100 = 800 \left[\left(\frac{4v_1^2 - v_1^2}{2} \right) + 10 \times (0 - 1) \right]$$

$$\frac{41}{8} + 10 = \frac{3v_1^2}{2}$$

$$\frac{121}{8} \times \frac{2}{3} = v_1^2$$

$$v_1 = \sqrt{\frac{121}{4 \times 3} \times \frac{3}{3}}$$

$$v_1 = \frac{\sqrt{363}}{6} \text{ m/s}$$