

FINAL JEE-MAIN EXAMINATION – JANUARY, 2023

(Held On Monday 30th January, 2023)

TIME : 9 : 00 AM to 12 : 00 NOON

SECTION-A

61. Let $A = \begin{pmatrix} m & n \\ p & q \end{pmatrix}$, $d = |A| \neq 0$ $|A - d(\text{Adj}A)| = 0$

. Then

(1) $(1+d)^2 = (m+q)^2$

(2) $1+d^2 = (m+q)^2$

(3) $(1+d)^2 = m^2 + q^2$

(4) $1+d^2 = m^2 + q^2$

Official Ans. by NTA (1)

Ans. (1)

Sol. $A = \begin{bmatrix} m & n \\ p & q \end{bmatrix}$, $|A - d(\text{adj}A)| = 0$

$$\Rightarrow \begin{vmatrix} m - dq & n - dp \\ p - dq & q - dp \end{vmatrix} = 0$$

$$= \begin{vmatrix} m - qd & n(1+d) \\ p(1+d) & q - md \end{vmatrix} = 0$$

$$\Rightarrow (m - qd)(q - md) - np(1+d)^2 = 0$$

$$\Rightarrow mq - m^2d - q^2d + mqd^2 - np(1+d)^2 = 0$$

$$\Rightarrow (mq - np) + d^2(mq - np) - d(m^2 + q^2 + 2np) = 0$$

$$\Rightarrow d + d^3 - d((m+q)^2 - 2d) = 0$$

$$\Rightarrow 1 + d^2 = (m+q)^2 - 2d$$

$$\Rightarrow (1+d)^2 = (m+q)^2$$

∴ Option (1) is correct.

62. The line l_1 passes through the point $(2,6,2)$ and is perpendicular to the plane $2x + y - 2z = 10$. Then the shortest distance between the line l_1 and the

line $\frac{x+1}{2} = \frac{y+4}{-3} = \frac{z}{2}$ is :

(1) 7 (2) $\frac{19}{3}$

(3) $\frac{19}{3}$ (4) 9

Official Ans. by NTA (4)

Ans. (4)

Sol. Line l , is given by

$$L_1: \frac{x-2}{2} = \frac{y-6}{1} = \frac{z-2}{-2}$$

Given,

$$L_2: \frac{x+1}{2} = \frac{y+4}{-3} = \frac{z}{2}$$

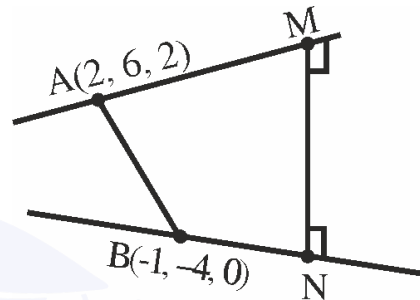

$$\text{Shortest distance} = \left| \frac{\overline{AB} \cdot \overline{MN}}{|\overline{MN}|} \right|$$

$$\overline{AB} = 3\hat{i} + 10\hat{j} + 2\hat{k}$$

$$\overline{MN} = \begin{vmatrix} \hat{i} & \hat{j} & \hat{k} \\ 2 & 1 & -2 \\ 2 & -3 & 2 \end{vmatrix} = -4\hat{i} - 8\hat{j} - 8\hat{k}$$

$$MN = \sqrt{16 + 64 + 64} = 12$$

$$\therefore \text{Shortest distance} = \left| \frac{-12 - 80 - 16}{12} \right| = 9$$

∴ Option (4) is correct.

63. If an unbiased die, marked with $-2, -1, 0, 1, 2, 3$ on its faces, is through five times, then the probability that the product of the outcomes is positive, is :

(1) $\frac{881}{2592}$

(2) $\frac{521}{2592}$

(3) $\frac{440}{2592}$

(4) $\frac{27}{288}$

Official Ans. by NTA (2)

Ans. (2)

Sol. Either all outcomes are positive or any two are negative.

$$\text{Now, } p = P(\text{positive}) = \frac{3}{6} = \frac{1}{2}$$

$$q = p(\text{negative}) = \frac{2}{6} = \frac{1}{3}$$

Required probability

$$\begin{aligned} &= {}^5C_5 \left(\frac{1}{2}\right)^5 + {}^5C_2 \left(\frac{1}{3}\right)^2 \left(\frac{1}{2}\right)^3 + {}^5C_4 \left(\frac{1}{3}\right)^4 \left(\frac{1}{2}\right)^1 \\ &= \frac{521}{2592} \end{aligned}$$

\therefore Option (2) is correct.

64. Let the system of linear equations

$$x + y + kz = 2$$

$$2x + 3y - z = 1$$

$$3x + 4y + 2z = k$$

have infinitely many solutions. Then the system

$$(k+1)x + (2k-1)y = 7$$

$$(2k+1)x + (k+5)y = 10 \text{ has :}$$

- (1) infinitely many solutions
- (2) unique solution satisfying $x - y = 1$
- (3) no solution
- (4) unique solution satisfying $x + y = 1$

Official Ans. by NTA (4)

Ans. (4)

Sol.
$$\begin{vmatrix} 1 & 1 & k \\ 2 & 3 & -1 \\ & & 2 \end{vmatrix} = 0$$

$$\Rightarrow 1(10) - 1(7) + k(-1) - 0$$

$$\Rightarrow k = 3$$

For $k = 3$, 2nd system is

$$4x + 5y = 7 \quad \dots(1)$$

and $7x + 8y = 10 \quad \dots(2)$

Clearly, they have a unique solution

$$(2) - (1) \Rightarrow 3x + 3y = 3$$

$$\Rightarrow x + y = 1$$

65. If $\tan 15^\circ + \frac{1}{\tan 75^\circ} + \frac{1}{\tan 105^\circ} + \tan 195^\circ = 2a$,

then the value of $\left(a + \frac{1}{a}\right)$ is :

(1) 4 (2) $4 - 2\sqrt{3}$

(3) 2 (4) $5 - \frac{3}{2}\sqrt{3}$

Official Ans. by NTA (1)

Ans. (1)

Sol. Option (1)

$$\tan 15^\circ = 2 - \sqrt{3}$$

$$\frac{1}{\tan 75^\circ} = \cot 75^\circ = 2 - \sqrt{3}$$

$$\frac{1}{\tan 105^\circ} = \cot(105^\circ) = -\cot 75^\circ = \sqrt{3} - 2$$

$$\tan 195^\circ = \tan 15^\circ = 2 - \sqrt{3}$$

$$\therefore 2(2 - \sqrt{3}) = 2a \Rightarrow a = 2 - \sqrt{3}$$

$$\Rightarrow a + \frac{1}{a} = 4$$

66. Suppose $f : \mathbb{R} \rightarrow (0, \infty)$ be a differentiable function such that $5f(x+y) = f(x) \cdot f(y), \forall x, y \in \mathbb{R}$. If

f is equal to :

- (1) 6875 (2) 6575
- (3) 6825 (4) 6528

Official Ans. by NTA (3)

Ans. (3)

Sol. Option (3)

$$5f(x+y) = f(x) \cdot f(y)$$

$$5f(0) = f(0)^2 \Rightarrow f(0) = 5$$

$$5f(x+1) = f(x) \cdot f(1)$$

$$\Rightarrow \frac{f(x+1)}{f(x)} = \frac{f(1)}{5}$$

$$\Rightarrow \frac{f(1)}{f(0)} \cdot \frac{f(2)}{f(1)} \cdot \frac{f(3)}{f(2)} = \left(\frac{f(1)}{5}\right)^3$$

$$\Rightarrow \frac{320}{5} = \frac{(f(1))^3}{5^3} \Rightarrow f(1) = 20$$

$$\therefore 5f(x+1) = 20 \cdot f(x) \Rightarrow f(x+1) = 4f(x)$$

$$\sum_{n=0}^5 f(n) = 5 + 5 \cdot 4 + 5 \cdot 4^2 + 5 \cdot 4^3 + 5 \cdot 4^4 + 5 \cdot 4^5$$

$$= \frac{5[4^6 - 1]}{3} = 6825$$

67. If $a_n = \frac{-2}{4n^2 - 16n + 15}$, then $a_1 + a_2 + \dots + a_{25}$ is equal to :

- (1) $\frac{51}{144}$ (2) $\frac{49}{138}$
 (3) $\frac{50}{141}$ (4) $\frac{52}{147}$

Official Ans. by NTA (3)

Ans. (3)

Sol. Option (3)

If $a_n = \frac{-2}{4n^2 - 16n + 15}$ then $a_1 + a_2 + \dots + a_{25}$

$$\begin{aligned} \Rightarrow \sum_{n=1}^{25} a_n &= \sum_{n=1}^{25} \frac{-2}{4n^2 - 16n + 15} \\ &= \sum_{n=1}^{25} \frac{-2}{4n^2 - 6n - 10n + 15} \\ &= \sum_{n=1}^{25} \frac{-2}{2n(2n-3) - 5(2n-3)} \\ &= \sum_{n=1}^{25} \frac{-2}{(2n-3)(2n-5)} \\ &= \sum_{n=1}^{25} \frac{1}{2n-3} - \frac{1}{2n-5} \\ &= \frac{1}{47} - \frac{1}{(-3)} \\ &= \frac{50}{141} \end{aligned}$$

68. If the coefficient of x^{15} in the expansion of

$$\left(ax^3 + \frac{1}{bx^{\frac{1}{3}}} \right)^{15}$$

is equal to the coefficient of x^{-15} in

the expansion of $\left(ax^{\frac{1}{3}} - \frac{1}{bx^3} \right)^{15}$, where a and b

are positive real numbers, then for each such ordered pair (a, b) :

- (1) $a = b$ (2) $ab = 1$
 (3) $a = 3b$ (4) $ab = 3$

Official Ans. by NTA (2)

Ans. (2)

Sol. Option (2)

Coefficient Of x^{15} in $\left(ax^3 + \frac{1}{bx^{1/3}} \right)^{15}$

$$T_{r+1} = {}^{15}C_r (ax^3)^{15-r} \left(\frac{1}{bx^{1/3}} \right)^r$$

$$45 - 3r - \frac{r}{3} = 15$$

$$30 = \frac{10r}{3}$$

$$r = 9$$

$$\text{Coefficient of } x^{15} = {}^{15}C_9 a^6 b^{-9}$$

Coefficient of x^{-15} in $\left(ax^{1/3} - \frac{1}{bx^3} \right)^{15}$

$$T_{r+1} = {}^{15}C_r (ax^{1/3})^{15-r} \left(-\frac{1}{bx^3} \right)^r$$

$$5 - \frac{r}{3} - 3r = -15$$

$$\frac{10r}{3} = 20$$

$$r = 6$$

$$\text{Coefficient} = {}^{15}C_6 a^9 \times b^{-6}$$

$$\Rightarrow \frac{a^9}{b^6} = \frac{a^6}{b^9}$$

$$\Rightarrow a^3 b^3 = 1 \Rightarrow ab = 1$$

69. If $\vec{a}, \vec{b}, \vec{c}$ are three non-zero vectors and \hat{n} is a unit

vector perpendicular to \vec{c} such that

$$\vec{a} = \alpha \vec{b} - \hat{n}, (\alpha \neq 0) \quad \text{and} \quad \vec{b} \cdot \vec{c} = 12, \quad \text{then}$$

$|\vec{c} \times (\vec{a} \times \vec{b})|$ is equal to :

- (1) 15
 (2) 9
 (3) 12
 (4) 6

Official Ans. by NTA (3)

Ans. (3)

Sol. $\hat{n} \perp \vec{c} \quad \vec{a} = \alpha \vec{b} - \vec{n}$

$$\vec{b} \cdot \vec{c} = 12$$

$$\vec{a} \cdot \vec{c} = \alpha(\vec{b} \cdot \vec{c}) - \vec{n} \cdot \vec{c}$$

$$\vec{a} \cdot \vec{c} = \alpha(\vec{b} \cdot \vec{c})$$

$$|\vec{c} \times (\vec{a} \times \vec{b})| = |(\vec{c} \cdot \vec{b})\vec{a} - (\vec{c} \cdot \vec{a})\vec{b}|$$

$$= |(\vec{c} \cdot \vec{b})\vec{a} - \alpha(\vec{b} \cdot \vec{c})\vec{b}|$$

$$= |(\vec{c} \cdot \vec{b})| |\vec{a} - \alpha \vec{b}|$$

$$= 12 \times (|\vec{n}|)$$

$$= 12 \times 1$$

$$= 12$$

70. The number of points on the curve $y = 54x^5 - 135x^4 - 70x^3 + 180x^2 + 210x$ at which the normal lines are parallel to $x + 90y + 2 = 0$ is :

(1) 2 (2) 3

(3) 4 (4) 0

Official Ans. by NTA (3)

□ Ans. (3)

Sol. Normal of line is parallel to line $x + 90y + 2 = 0$

$$m_N = -\frac{1}{90}$$

$$-\left(\frac{dx}{dy}\right)_{(x_1, y_1)} = -\frac{1}{90} \Rightarrow \left(\frac{dy}{dx}\right)_{(x_1, y_1)} = 90$$

Now,

$$\frac{dy}{dx} = 270x^4 - 540x^3 - 210x^2 + 360x + 210 = 90$$

$$\Rightarrow x = 1, 2, \frac{-2}{3}, \frac{-1}{3}$$

(4) normals

71. Let $y = x + 2, 4y = 3x + 6$ and $3y = 4x + 1$ be three tangent lines to the circle $(x - h)^2 + (y - k)^2 = r^2$. Then $h + k$ is equal to :

(1) 5

(2) $5(1 + \sqrt{2})$

(3) 6

(4) $5\sqrt{2}$

Official Ans. by NTA (1)

Ans. (1)

Sol. $L_1 : y = x + 2, L_2 : 4y = 3x + 6, L_3 : 3y = 4x + 1$
Bisector of lines L_2 & L_3

$$\frac{4x - 3y + 1}{5} = \pm \left(\frac{3x - 4y + 6}{5} \right)$$

(+) $4x - 3y + 1 = 3x - 4y + 6$
 $x + y = 5$

Centre lies on Bisector of $4x - 3y + 1 = 0$ &

(0) $3x - 4y + 6 = 0$

$$\Rightarrow h + k = 5$$

72. Let the solution curve $y = y(x)$ of the differential

equation
$$\frac{dy}{dx} - \frac{3x^5 \tan^{-1}(x^3)}{(1+x^6)^{\frac{3}{2}}} y = 2x$$

$\exp \frac{x^3 - \tan^{-1} x^3}{\sqrt{(1+x)^6}}$ pass through the origin. Then

$y(1)$ is equal to :

(1) $\exp\left(\frac{4-\pi}{4\sqrt{2}}\right)$ (2) $\exp\left(\frac{\pi-4}{4\sqrt{2}}\right)$

(3) $\exp\left(\frac{1-\pi}{4\sqrt{2}}\right)$ (4) $\exp\left(\frac{4+\pi}{4\sqrt{2}}\right)$

Official Ans. by NTA (1)

□ Ans. (1)

Sol.
$$\frac{dy}{dx} + \left(\frac{-3x^5 \tan^{-1} x^3}{(1+x^6)^{3/2}} \right) y = 2e^{\left(\frac{x - \tan x}{\sqrt{1+x^6}} \right)}$$

$$\text{I.F.} = e^{\int \frac{-3x^5 \tan^{-1} x^3}{(1+x^6)^{3/2}} dx}$$

$$\sqrt{\quad}$$

Solution of differential equation

$$y \cdot e^{\frac{\tan^{-1} x^3 - x^3}{\sqrt{1+x^6}}} = \int 2x e^{\left(\frac{x^3 - \tan^{-1} x^3}{\sqrt{1+x^6}} \right)} \cdot e^{\left(\frac{\tan^{-1}(x^3) - x^3}{\sqrt{1+x^6}} \right)} dx$$

$$y \cdot e^{\frac{\tan^{-1} x^3 - x^3}{\sqrt{1+x^6}}} = x^2 + c$$

Also it passes through origin

$$c = 0$$

$$y(1) \cdot e^{\frac{\tan^{-1}(1)-1}{\sqrt{2}}} = 1$$

$$y(1) \cdot e^{\frac{\frac{\pi}{4}-1}{\sqrt{2}}} = 1$$

$$y(1) \cdot e^{\frac{\pi-4}{4\sqrt{2}}} = 1$$

$$y(1) = \frac{1}{e^{\frac{\pi-4}{4\sqrt{2}}}} = e^{\frac{4-\pi}{4\sqrt{2}}}$$

73. Let a unit vector OP make angle α, β, γ with the positive directions of the co-ordinate axes OX, OY, OZ respectively, where $\beta \in \left(0, \frac{\pi}{2}\right)$ OP is perpendicular to the plane through points (1, 2, 3), (2, 3, 4) and (1, 5, 7), then which one of the following is true ?

- (1) $\alpha \in \left(\frac{\pi}{2}, \pi\right)$ and $\gamma \in \left(\frac{\pi}{2}, \pi\right)$
 (2) $\alpha \in \left(0, \frac{\pi}{2}\right)$ and $\gamma \in \left(0, \frac{\pi}{2}\right)$
 (3) $\alpha \in \left(\frac{\pi}{2}, \pi\right)$ and $\gamma \in \left(0, \frac{\pi}{2}\right)$
 (4) $\alpha \in \left(0, \frac{\pi}{2}\right)$ and $\gamma \in \left(\frac{\pi}{2}, \pi\right)$

Official Ans. by NTA (1)

Ans. (1)

Sol. Equation of plane :-

$$\begin{vmatrix} x-1 & y-2 & z-3 \\ 1 & 1 & 1 \\ 0 & 3 & 4 \end{vmatrix} = 0$$

$$\Rightarrow [x-1] - 4[y-2] + 3[z-3] = 0$$

$$\Rightarrow x - 4y + 3z = 2$$

D.R's of normal of plane $\langle 1, -4, 3 \rangle$

$$\text{D.C's of } \left\langle \pm \frac{1}{\sqrt{26}}, \mp \frac{4}{\sqrt{26}}, \pm \frac{3}{\sqrt{26}} \right\rangle$$

$$\cos \beta = \frac{4}{\sqrt{26}}$$

$$\cos \alpha = \frac{-1}{\sqrt{26}} \quad \frac{\pi}{2} < \alpha < \pi$$

$$\cos \gamma = \frac{-3}{\sqrt{26}} \quad \frac{\pi}{2} < \gamma < \pi$$

Ans. : (1)

74. If $[t]$ denotes the greatest integer $\leq t$, then the value

$$\text{of } \frac{3(e-1)^2}{e} \int_1^2 x^2 e^{[x]+[x^3]} dx \text{ is :}$$

- (1) $e^9 - e$ (2) $e^8 - e$
 (3) $e^7 - 1$ (4) $e^8 - 1$

Official Ans. by NTA (2)

Ans. (2)

Sol. $\int_1^2 x^2 e^{[x^3]+1} dx$

$$x^3 = t$$

$$3x^2 dx = dt$$

$$= \frac{e}{3} \int_1^8 e^{[t]} dt$$

$$= \frac{e}{3} \left\{ \int_1^2 e dt + \int_2^3 e^2 dt + \dots + \int_7^8 e^7 dt \right\}$$

$$= \frac{e}{3} (e + e^2 + \dots + e^7)$$

$$= \frac{e^2}{3} (1 + e + \dots + e^6) = \frac{e^2}{3} \frac{(e^7 - 1)}{(e - 1)}$$

$$\frac{3(e-1)}{e} \int_1^2 x^2 \times e^{[x]+[x^3]} dx = \frac{3}{e} (e-1) \times \frac{e^2}{3} \frac{(e^7 - 1)}{(e - 1)}$$

$$= e(e^7 - 1)$$

$$= e^8 - e$$

Ans. : (2)

75. If P(h,k) be point on the parabola $x = 4y^2$, which is nearest to the point Q(0,33), then the distance of P from the directrix of the parabola $y^2 = 4(x + y)$ is equal to :

- (1) 2 (2) 4
 (3) 8 (4) 6

Official Ans. by NTA (4)

Ans. (4)

Sol. Equation of normal

$$y = -tx + 2at + at^3$$

$$y = -tx + \frac{2}{16}t + \frac{1}{16}t^3$$

It passes through (0, 33)

$$33 = \frac{t}{8} + \frac{t^3}{16}$$

$$t^3 + 2t - 528 = 0$$

$$(t - 8)(t^2 + 8t + 66) = 0$$

$$t = 8$$

$$P(at^2, 2at) = \left(\frac{1}{16} \times 64, 2 \times \frac{1}{16} \times 8 \right) = (4, 1)$$

Parabola :

$$y^2 = 4(x + y)$$

$$\Rightarrow y^2 - 4y = 4x$$

$$\Rightarrow (y - 2)^2 = 4(x + 1)$$

Equation of directrix :-

$$x + 1 = -1$$

$$x = -2$$

Distance of point = 6

Ans. : (4)

76. A straight line cuts off the intercepts $OA = a$ and $OB = b$ on the positive directions of x -axis and y -axis respectively. If the perpendicular from origin O to this line makes an angle of $\frac{\pi}{6}$ with positive direction of y -axis and the area of ΔOAB is $\frac{98}{3}\sqrt{3}$, then $a^2 - b^2$ is equal to:

- (1) $\frac{392}{3}$ (2) 196
 (3) $\frac{196}{3}$ (4) 98

Official Ans. by NTA (1)

Ans. (1)

Sol.

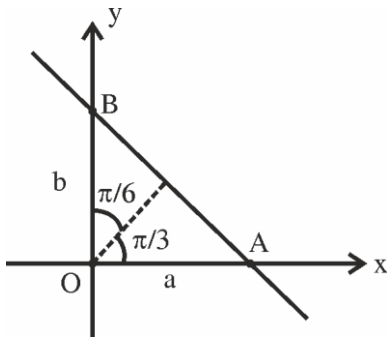

Equation of straight line : $\frac{x}{a} + \frac{y}{b} = 1$

Or $x \cos \frac{\pi}{3} + y \sin \frac{\pi}{3} = p$

$\frac{x}{2} + \frac{\sqrt{y}}{2} = p$

$\frac{x}{3p} + \frac{y}{2p} = 1$

Comparing both : $a = 2p, b = \frac{2p}{\sqrt{3}}$

Now area of $\Delta OAB = \frac{1}{2} \cdot ab = \frac{98}{3} \cdot \sqrt{3}$

$\frac{1}{2} \cdot 2p \cdot \frac{2p}{\sqrt{3}} = \frac{98}{3} \cdot \sqrt{3}$

$p^2 = 49$

$a^2 - b^2 = 4p^2 - \frac{4p^2}{3} = \frac{2}{3} 4p^2$

$= \frac{8}{3} \cdot 49 = \frac{392}{3}$

77. The coefficient of x^{301} in $(1+x)^{500} + x(1+x)^{499} + x^2(1+x)^{498} + \dots + x^{500}$ is:

- (1) ${}^{501}C_{302}$ (2) ${}^{500}C_{301}$
 (3) ${}^{500}C_{300}$ (4) ${}^{501}C_{200}$

Official Ans. by NTA (4)

Ans. (4)

Sol. $(1+x)^{500} + x(1+x)^{499} + x^2(1+x)^{498} + \dots + x^{500}$

$= (1+x)^{500} \cdot \left\{ \frac{1 - \left(\frac{x}{1+x}\right)^{501}}{1 - \frac{x}{1+x}} \right\}$

$= (1+x)^{500} \frac{\left((1+x)^{501} - x^{501}\right)}{1+x}$

$= (1+x)^{501} - x^{501}$

Coefficient of x^{301} in $(1+x)^{501} - x^{501}$ is given by

${}^{501}C_{301} = {}^{501}C_{200}$

78. Among the statements:

- (S1) $((p \vee q) \Rightarrow r) \Leftrightarrow (p \Rightarrow r)$
 (S2) $((p \vee q) \Rightarrow r) \Leftrightarrow ((p \Rightarrow r) \vee (q \Rightarrow r))$

- (1) Only (S1) is a tautology
 (2) Neither (S1) nor (S2) is a tautology
 (3) Only (S2) is a tautology
 (4) Both (S1) and (S2) are tautologies

Official Ans. by NTA (2)

Ans. (2)

Sol. $S_1 \equiv ((p \vee q) \Rightarrow r) \Leftrightarrow (p \Rightarrow r)$

p	q	r	$p \vee q$	$(p \vee q) \Rightarrow r$	$p \Rightarrow r$	$((p \vee q) \Rightarrow r) \Leftrightarrow (p \Rightarrow r)$
T	T	T	T	T	T	T
T	T	F	T	F	F	T
T	F	T	T	T	T	T
F	T	T	T	T	T	T
T	F	F	T	F	F	T
F	T	F	T	F	T	T
F	F	F	T	T	T	T
F	F	F	F	T	T	T

$$S_2 \equiv (p \vee q) \Rightarrow r \Leftrightarrow ((p \Rightarrow r) \vee (q \Rightarrow r))$$

P	q	r	$(p \vee q) \Rightarrow r$	$p \Rightarrow r$	$q \Rightarrow r$	$(p \Rightarrow r) \vee (q \Rightarrow r)$	S2
T	T	T	T	T	T	T	T
T	T	F	F	F	F	T	T
T	F	T	T	T	T	T	T
F	T	T	T	T	T	T	T
T	F	F	F	T	T	T	F
F	T	F	F	F	F	T	F
F	F	T	T	T	T	T	T
F	F	F	T	T	T	T	T

S2 \rightarrow not a tautology

79. The minimum number of elements that must be added to the relation $R = \{(a,b), (b,c)\}$ on the set $\{a,b,c\}$ so that it becomes symmetric and transitive is:

- (1) 4 (2) 7
(3) 5 (4) 3

Official Ans. by NTA (2)

Ans. (2)

Sol. For Symmetric $(a,b), (b,c) \in R$

$$\Rightarrow (b,a), (c,b) \in R$$

For Transitive $(a,b), (b,c) \in R$

$$\Rightarrow (a,c) \in R$$

Now

1. Symmetric

$$\therefore (a,c) \in R \Rightarrow (c,a) \in R$$

2. Transitive

$$\therefore (a,b), (b,a) \in R$$

$$\Rightarrow (a,a) \in R \text{ \& } (b,c), (c,b) \in R$$

$$\Rightarrow (b,b) \text{ \& } (c,c) \in R$$

\therefore Elements to be added

$$\left\{ \begin{array}{l} (b,a), (c,b), (a,c), (c,a) \\ (a,a), (b,b), (c,c) \end{array} \right\}$$

Number of elements to be added = 7

80. If the solution of the equation $\log_{\cos x} \cot x + 4 \log_{\sin x} \tan x = 1, x \in \left(0, \frac{\pi}{2}\right)$, is

$$\sin^{-1} \left(\frac{\alpha + \sqrt{\beta}}{2} \right), \text{ where } \alpha, \beta \text{ are integers, then}$$

$\alpha + \beta$ is equal to:

- (1) 3
(2) 5
(3) 6
(4) 4

Official Ans. by NTA (4)

Ans. (4)

Sol.

$$\log_{\cos x} \cot x + 4 \log_{\sin x} \tan x = 1$$

$$\Rightarrow \frac{\ln \cos x - \ln \sin x}{\ln \cos x} + 4 \frac{\ln \sin x - \ln \cos x}{\ln \sin x} = 1$$

$$\Rightarrow (\ln \sin x)^2 - 4(\ln \sin x)(\ln \cos x) + 4(\ln \cos x)^2 = 1$$

$$\Rightarrow \ln \sin x = 2 \ln \cos x$$

$$\Rightarrow \sin^2 x + \sin x - 1 = 0 \Rightarrow \sin x = \frac{-1 + \sqrt{5}}{2}$$

$$\therefore \alpha + \beta = 4$$

Correct option (4)

SECTION-B

81. Let $S = \{1, 2, 3, 4, 5, 6\}$. Then the number of one-one functions $f: S \rightarrow P(S)$, where $P(S)$ denote the power set of S , such that $f(n) \subset f(m)$ where $n < m$ is _____.

Official Ans. by NTA (3240)

Ans. (3240)

Sol. Let $S = \{1, 2, 3, 4, 5, 6\}$, then the number of one-one functions, $f: S \rightarrow P(S)$, where $P(S)$ denotes the power set of S , such that $f(n) \subset f(m)$ where $n < m$ is

$$n(S) = 6$$

$$P(S) = \left\{ \begin{array}{l} \phi, \{1\}, \dots, \{6\}, \{1, 2\}, \dots, \\ \{5, 6\}, \dots, \{1, 2, 3, 4, 5, 6\} \end{array} \right\}$$

- 64 elements

case – 1

$f(6) = S$ i.e. 1 option,

$f(5) =$ any 5 element subset A of S i.e. 6 options,

$f(4) =$ any 4 element subset B of A i.e. 5 options,

$f(3) =$ any 3 element subset C of B i.e. 4 options,

$f(2) =$ any 2 element subset D of C i.e. 3 options,

$f(1) =$ any 1 element subset E of D or empty subset i.e. 3 options,

Total functions = 1080

Case – 2

$f(6) =$ any 5 element subset A of S i.e. 6 options,

$f(5) =$ any 4 element subset B of A i.e. 5 options,

$f(4) =$ any 3 element subset C of B i.e. 4 options,

$f(3) =$ any 2 element subset D of C i.e. 3 options,

$f(2) =$ any 1 element subset E of D i.e. 2 options,

$f(1) =$ empty subset i.e. 1 option

Total functions = 720

Case – 3

$f(6) = S$

$f(5) =$ any 4 element subset A of S i.e. 15 options,

$f(4) =$ any 3 element subset B of A i.e. 4 options,

$f(3) =$ any 2 element subset C of B i.e. 3 options,

$f(2) =$ any 1 element subset D of C i.e. 2 options,

$f(1) =$ empty subset i.e. 1 option

Total functions = 360

Case – 4

$f(6) = S$

$f(5) =$ any 5 element subset A of S i.e. 6 options,

$f(4) =$ any 3 element subset B of A i.e. 10 options,

$f(3) =$ any 2 element subset C of B i.e. 3 options,

$f(2) =$ any 1 element subset D of C i.e. 2 options,

$f(1) =$ empty subset i.e. 1 option

Total functions = 360

Case – 5

$f(6) = S$

$f(5) =$ any 5 element subset A of S i.e. 6 options,

$f(4) =$ any 4 element subset B of A i.e. 5 options,

$f(3) =$ any 2 element subset C of B i.e. 6 options,

$f(2) =$ any 1 element subset D of C i.e. 2 options,

$f(1) =$ empty subset i.e. 1 option

Total functions = 360

Case – 6

$f(6) = S$

$f(5) =$ any 5 element subset A of S i.e. 6 options,

$f(4) =$ any 4 element subset B of A i.e. 5 options,

$f(3) =$ any 3 element subset C of B i.e. 4 options,

$f(2) =$ any 1 element subset D of C i.e. 3 options,

$f(1) =$ empty subset i.e. 1 option

Total functions = 360

\therefore Number of such functions = 3240

82. Let α be the area of the larger region bounded by the curve $y^2 = 8x$ and the lines $y = x$ and $x = 2$, which lies in the first quadrant. Then the value of 3α is equal to _____.

Official Ans. by NTA (22)

Ans. (22)

Sol.

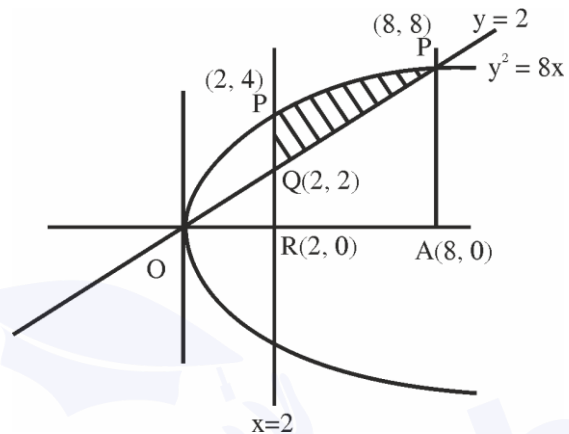

$$y = x$$

$$\& y^2 = 8x$$

Solving it

$$x^2 = 8x$$

$$\therefore x = 0, 8$$

$$\therefore y = 0, 8$$

$x = 2$ will intersect occur at

$$y^2 = 16 \Rightarrow y = \pm 4$$

\therefore Area of shaded

$$= \int_2^8 (\sqrt{8x} - x) dx = \int_2^8 (2\sqrt{2}\sqrt{x} - x) dx$$

$$= \left[2\sqrt{2} \cdot \frac{x^{3/2}}{3/2} - \frac{x^2}{2} \right]_2^8$$

$$= \left(\frac{4\sqrt{2}}{3} \cdot 2^{9/2} - 32 \right) - \left(\frac{4\sqrt{2}}{3} \cdot 2^{9/2} - 2 \right)$$

$$= \frac{128}{3} - 32 - \frac{16}{3} + 2 = \frac{112 - 90}{3} = \frac{22}{3} = A$$

$$\therefore 3A = 22$$

83. If $\lambda_1 < \lambda_2$ are two values of λ such that the angle between the planes $P_1 : \vec{r} \cdot (3\hat{i} - 5\hat{j} + \hat{k}) = 7$ and $P_2 : \vec{r} \cdot (\lambda\hat{i} + \hat{j} - 3\hat{k}) = 9$ is $\sin^{-1}\left(\frac{2\sqrt{6}}{5}\right)$, then the square of the length of perpendicular from the point $(38\lambda_1, 10\lambda_2, 2)$ to the plane P_1 is _____.

Official Ans. by NTA (315)

Ans. (315)

Sol. $P_1 : \vec{r} \cdot (3\hat{i} - 5\hat{j} + \hat{k}) = 7$

$P_2 : \vec{r} \cdot (\lambda\hat{i} + \hat{j} - 3\hat{k}) = 9$

$\theta = \sin^{-1}\left(\frac{2\sqrt{6}}{5}\right)$

$\Rightarrow \sin \theta = \frac{2\sqrt{6}}{5}$

$\therefore \cos \theta = \frac{1}{5}$

$\cos \theta = \frac{\vec{r}_1 \cdot \vec{r}_2}{|\vec{r}_1| |\vec{r}_2|}$

$= \frac{(3 \quad \text{K})(\lambda\hat{i} + \hat{j} - 3\hat{k})}{\sqrt{35} \cdot \sqrt{\lambda^2 + 10}}$

$\frac{1}{5} = \left| \frac{3\lambda - 8}{\sqrt{35} \cdot \sqrt{\lambda^2 + 10}} \right|$

Square $\Rightarrow \frac{1}{25} = \frac{9\lambda^2 + 64 - 48\lambda}{35(\lambda^2 + 10)}$

$\Rightarrow 19\lambda^2 - 120\lambda + 125 = 0$

$\Rightarrow 19\lambda^2 - 95\lambda - 25\lambda + 125 = 0$

$\Rightarrow x = 5, \frac{25}{19}$

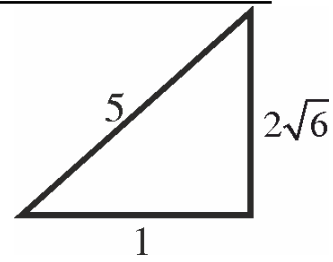

Perpendicular distance of point

$(38\lambda_1, 10\lambda_2, 2) \equiv (50, 50, 2)$ from plane P_1

$= \frac{|3 \times 50 - 5 \times 50 + 2 - 7|}{\sqrt{35}} = \frac{105}{\sqrt{35}}$

Square $= \frac{105 \times 105}{35} = 315$

84. Let $z = 1 + i$ and $z_1 = \frac{1 + i\bar{z}}{\bar{z}(1-z) + \frac{1}{z}}$. Then $\frac{12}{\pi}$

$\arg(z_1)$ is equal to _____.

Official Ans. by NTA (9)

Ans. (9)

Sol. $z = 1 + i$

$z_1 = \frac{1 + i\bar{z}}{\bar{z}(1-z) + \frac{1}{z}}$

$z_1 = \frac{1 + i(1-i)}{(1-i)(1-1-i) + \frac{1}{1+i}}$

$= \frac{1 + i - i^2}{(1-i)(-i) + \frac{1-i}{2}}$

$= \frac{2 + i}{-3i - 1} = \frac{4 + 2i}{-3i - 1}$

$= \frac{-(4 + 2i)(3i - 1)}{(3i)^2 - (1)^2}$

$\text{Arg}(z_1) = \frac{3\pi}{4}$

$\therefore \frac{12}{\pi} \arg(z_1) = \frac{12}{\pi} \times \frac{3\pi}{4} = 9$

85. $\lim_{x \rightarrow 0} \frac{48}{x^4} \int_0^x \frac{t^3}{t^6 + 1} dt$ is equal to _____.

Official Ans. by NTA (12)

Ans. (12)

Sol. $48 \lim_{x \rightarrow 0} \frac{\int_0^x \frac{t^3}{t^6 + 1} dt}{x^4} \left(\frac{0}{0} \right)$

Applying L' Hospital's Rule

$$48 \lim_{x \rightarrow 0} \frac{x^3}{x^6 + 1} \times \frac{1}{4x^3}$$

$$= 12$$

86. The mean and variance of 7 observations are 8 and 16 respectively. If one observation 14 is omitted and a and b are respectively mean and variance of remaining 6 observation, then $a + 3b - 5$ is equal to _____.

Official Ans. by NTA (37)

Ans. (37)

Sol. $\frac{x_1 + x_2 + \dots + x_7}{7} = 8$

$$\frac{x_1 + x_2 + x_3 + \dots + x_6 + 14}{7} = 8$$

$$\Rightarrow x_1 + x_2 + \dots + x_6 = 42$$

$$\therefore \frac{x_1 + x_2 + \dots + x_6}{6} = \frac{42}{6} = 7 = a$$

$$\frac{\sum x_i^2}{7} - 8^2 = 16$$

$$\sum x_i^2 = 560$$

$$\Rightarrow x_1^2 + x_2^2 + \dots + x_6^2 = 364$$

$$b = \frac{x_1^2 + x_2^2 + \dots + x_6^2}{6} - 7^2$$

$$= \frac{364}{6} - 49$$

$$b = \frac{70}{6}$$

$$a + 3b - 5 = 7 + 3 \times \frac{70}{6} - 5$$

$$= 37$$

87. If the equation of the plane passing through the point (1,1,2) and perpendicular to the line $x - 3y + 2z - 1 = 0$ $4x - y + z$ is $Ax + By + Cz = 1$, then $140(C - B + A)$ is equal to _____.

Official Ans. by NTA (15)

Ans. (15)

Sol. $x - 3y + 2z - 1 = 0$

$$4x - y + z = 0$$

$$\vec{n}_1 \times \vec{n}_2 = \begin{vmatrix} \hat{i} & \hat{j} & \hat{k} \\ 1 & -3 & 2 \\ 4 & - & \end{vmatrix}$$

$$= -\hat{i} + 7\hat{j} + 11\hat{k}$$

Dir's of normal to the plane is -1, 7, 11

Equation of plane :

$$-1(x - 1) + 7(y - 1) + 11(z - 2) = 0$$

$$-x + 7y + 11z = 28$$

$$-1 \quad 7y \quad 11z$$

$$Ax + By + Cz = 1$$

$$140(C - B + A) = 140 \left(\frac{11}{28} - \frac{7}{28} - \frac{1}{28} \right)$$

$$= 140 \times \frac{3}{28} = 15$$

88. Let $\sum_{n=0}^{\infty} \frac{n^3 ((2n)!) + (2n-1)(n!)}{(n!)((2n)!)}$ = $ae + \frac{b}{e} + c$,

where $a, b, c \in \mathbb{Z}$ and $e = \sum_{n=0}^{\infty} \frac{1}{n!}$ Then $a^2 - b + c$ is

equal to _____.

Official Ans. by NTA (26)

Ans. (26)

Sol.
$$\sum_{n=0}^{\infty} \frac{n^3((2n)!)+(2n-1)(n!)}{(n!)((2n)!)}$$

$$= \sum_{n=0}^{\infty} \frac{1}{(n-3)!} + \sum_{n=0}^{\infty} \frac{3}{(n-2)!}$$

$$+ \sum_{n=0}^{\infty} \frac{1}{(n-1)!} + \sum_{n=0}^{\infty} \frac{1}{(2n-1)!} - \sum_{n=0}^{\infty} \frac{1}{(2n)!}$$

$$= e + 3e + e + \frac{1}{2} \left(e - \frac{1}{e} \right) - \frac{1}{2} \left(e + \frac{1}{e} \right)$$

$$= 5e - \frac{1}{e}$$

$\therefore a^2 - b + c = 26$

89. Number of 4-digit numbers (the repetition of digits is allowed) which are made using the digits 1, 2, 3 and 5, and are divisible by 15, is equal to _____

Official Ans. by NTA (21)

Ans. (21)

Sol. For number to be divisible by 15, last digit should be 5 and sum of digits must be divisible by 3.

Possible combinations are

1	2	1	5
---	---	---	---

Numbers = 3

2	2	3	5
---	---	---	---

Numbers = 3

3	3	1	5
---	---	---	---

Numbers = 3

1	1	5	5
---	---	---	---

Numbers = 3

2	3	5	5
---	---	---	---

Numbers = 6

3	5	5	5
---	---	---	---

Numbers = 3

Total Numbers = 21

90. Let $f^1(x) = \frac{3x+2}{2x+3}, x \in \mathbb{R} - \left\{ \frac{-3}{2} \right\}$

For $n \geq 2$, define $f^n(x) = f^1 \circ f^{n-1}(x)$.

If $f^5(x) = \frac{ax+b}{bx+a}, \gcd(a,b)=1$, then $a+b$ is equal

to _____.

Official Ans. by NTA (3125)

Ans. (3125)

Sol. $f^1(x) = \frac{3x+2}{2x+3}$

$$\Rightarrow f^2(x) = \frac{13x+12}{12x+13}$$

$$\Rightarrow f^3(x) = \frac{63x+62}{62x+63}$$

$$\therefore f^5(x) = \frac{1563x+1562}{1562x+1563}$$

$a+b = 3125$