

**FINAL JEE-MAIN EXAMINATION – JANUARY, 2023**

**(Held On Monday 30<sup>th</sup> January, 2023)**

**TIME : 9 : 00 AM to 12 : 00 NOON**

**SECTION-A**

1. The charge flowing in a conductor changes with time as  $Q(t) = \alpha t - \beta t^2 + \gamma t^3$ . Where  $\alpha, \beta$  and  $\gamma$  are constants. Minimum value of current is :

- (1)  $\alpha - \frac{3\beta^2}{\gamma}$                       (2)  $\alpha - \frac{\gamma^2}{3\beta}$   
 (3)  $\beta - \frac{\alpha^2}{3\gamma}$                       (4)  $\alpha - \frac{\beta^2}{3\gamma}$

**Official Ans. by NTA (4)**

**Ans. (4)**

**Sol.**  $Q = (\alpha t - \beta t^2 + \gamma t^3)$   
 $i = \frac{dQ}{dt} = (\alpha - 2\beta t + 3\gamma t^2)$   
 $\frac{di}{dt} = (3\gamma t - 2\beta) = 0$   
 $\Rightarrow t = \frac{\beta}{3\gamma}$

$i = (\alpha - 2\beta t + 3\gamma t^2) = \left( \alpha - \frac{\beta^2}{3\gamma} \right)$

2. The pressure (P) and temperature (T) relationship of an ideal gas obeys the equation  $PT^2 = \text{constant}$ . The volume expansion coefficient of the gas will be:

- (1)  $3T^2$                               (2)  $\frac{3}{T^2}$   
 (3)  $\frac{3}{T^3}$                               (4)  $\frac{3}{T}$

**Official Ans. by NTA (4)**

**Ans. (4)**

**Sol.**  $PT^2 = \text{constant}$ , Using  $PV = nRT$

$P = \frac{nRT}{V}$

$PT^2 = \frac{nRT}{V} \times T^2 = \text{constant}$

$\Rightarrow T^3 = KV$

So,  $\frac{d}{dT}(KV) = 3T^2$

$\Rightarrow \frac{KdV}{dT} = 3T^2$

$\Rightarrow dV = \frac{3T^2}{K} dT$

$dV = V \gamma dT$

$\Rightarrow \gamma V = \frac{3T^2}{K} \Rightarrow \gamma = \frac{3T^2}{KV} = \frac{3T^2}{T^3} = \frac{3}{T}$

3. A person has been using spectacles of power-1.0 diopter for distant vision and a separate reading glass of power 2.0 diopters. What is the least distance of distinct vision for this person:

- (1) 10 cm                              (2) 40 cm  
 (3) 30 cm                              (4) 50 cm

**Official Ans. by NTA (4)**

**Ans. (4)**

**Sol.**  $\frac{1}{v} - \frac{1}{u} = \frac{1}{f}$ ,

$P = 2D = 2m^{-1}$

$\Rightarrow \frac{1}{f} = \frac{2}{100} \text{ cm}^{-1}$

$\frac{1}{V} - \left( -\frac{1}{25} \right) = \frac{2}{100}$

$\Rightarrow \frac{1}{V} = \frac{1}{50} - \frac{1}{25}$

$\Rightarrow V = -50 \text{ cm}$

4. As per the given figure, a small ball P slides down the quadrant of a circle and hits the other ball Q of equal mass which is initially at rest. Neglecting the effect of friction and assume the collision to be elastic, the velocity of ball Q after collision will be : ( $g = 10 \text{ m/s}^2$ )

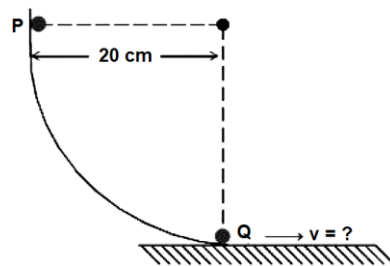

- (1) 0                                      (2) 0.25 m/s  
 (3) 2 m/s                              (4) 4 m/s

**Official Ans. by NTA (3)**

**Ans. (3)**

**Sol.** The velocities will be interchanged after collision.

Speed of P just before collision =  $\sqrt{2gh}$

=  $\sqrt{2 \times 10 \times 0.2} = 2 \text{ m/s}$

5. Choose the correct relationship between Poisson ratio ( $\sigma$ ), bulk modulus ( $K$ ) and modulus of rigidity ( $\eta$ ) of a given solid object:

(1)  $\sigma = \frac{3K - 2\eta}{6K + 2\eta}$       (2)  $\sigma = \frac{6K + 2\eta}{3K - 2\eta}$   
 (3)  $\sigma = \frac{3K + 2\eta}{6K + 2\eta}$       (4)  $\sigma = \frac{6K - 2\eta}{3K - 2\eta}$

Official Ans. by NTA (1)

Ans. (1)

Sol.  $Y = 3\eta(1 + \sigma)$

$Y = 3K(1 - \sigma)$

$\Rightarrow 2\eta(1 + \sigma) = 3K(1 - 2\sigma)$

$\Rightarrow \sigma = \left( \frac{3K - 2\eta}{6K + 2\eta} \right)$

6. The magnetic moments associated with two closely wound circular coils A and B of radius  $r_A = 10$  cm and  $r_B = 20$  cm respectively are equal if: (Where  $N_A, I_A$  and  $N_B, I_B$  are number of turn and current of A and B respectively)

(1)  $2N_A I_A = N_B I_B$       (2)  $N_A = 2N_B$   
 (3)  $N_A I_A = 4N_B I_B$       (4)  $4N_A I_A = N_B I_B$

Official Ans. by NTA (3)

Ans. (3)

Sol.  $M = NIA$

$M_A = M_B$

$\therefore N_A I_A A_A = N_B I_B A_B$

$\therefore N_A I_A \pi(0.1)^2 = N_B I_B \pi(0.2)^2$

$\therefore N_A I_A = 4N_B I_B$

7. A small object at rest, absorbs a light pulse of power 20 mW and duration 300 ns. Assuming speed of light as  $3 \times 10^8$  m/s. the momentum of the object becomes equal to :

(1)  $0.5 \times 10^{-17}$  kg m/s      (2)  $2 \times 10^{-17}$  kg m/s  
 (3)  $3 \times 10^{-17}$  kg m/s      (4)  $1 \times 10^{-17}$  kg m/s

Official Ans. by NTA (2)

Ans. (2)

Sol. Momentum =  $\frac{\text{Energy}}{C}$

=  $\frac{\text{Power} \times \text{time}}{C}$

=  $\frac{(20 \text{ w})(300 \times 10^{-9} \text{ s})}{3 \times 10^8 \text{ m/s}}$

=  $2 \times 10^{-17}$  kg-m/s

8. Speed of an electron in Bohr's 7<sup>th</sup> orbit for Hydrogen atom is  $3.6 \times 10^6$  m/s. The corresponding speed of the electron in 3<sup>rd</sup> orbit, in m/s is :

(1)  $(1.8 \times 10^6)$       (2)  $(7.5 \times 10^6)$   
 (3)  $(3.6 \times 10^6)$       (4)  $(8.4 \times 10^6)$

Official Ans. by NTA (4)

Ans. (4)

Sol.  $V_n \propto \frac{Z}{n}$

$Z = 1, \therefore V_n \propto \frac{1}{n}$

$\therefore \frac{V_3}{V_7} = \frac{7}{3}$

$\therefore V_3 = \frac{7}{3} V_7$

=  $\frac{7}{3} \times 3.6 \times 10^6 \text{ m/s}$

=  $8.4 \times 10^6 \text{ m/s}$

9. A massless square loop, of wire of resistance  $10 \Omega$ , supporting a mass of 1 g, hangs vertically with one of its sides in a uniform magnetic field of  $10^3$  G, directed outwards in the shaded region. A dc voltage  $V$  is applied to the loop. For what value of  $V$ , the magnetic force will exactly balance the weight of the supporting mass of 1g?

(If sides of the loop = 10 cm,  $g = 10 \text{ ms}^{-2}$ )

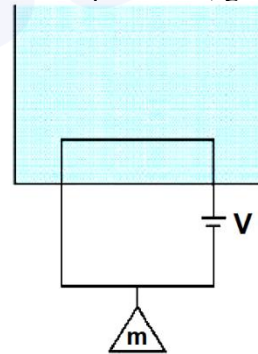

(1)  $\frac{1}{10}$  V      (2) 100 V  
 (3) 1 V      (4) 10 V

Official Ans. by NTA (4)

Ans. (4)

Sol.  $F_m = mg$

$\therefore ILB = mg$

$\therefore \left( \frac{V}{R} \right) LB = mg$

$\therefore V = \frac{mgR}{LB}$

=  $\frac{(1 \times 10^{-3} \text{ kg})(10 \text{ m/s}^2)(10 \Omega)}{(0.1 \text{ m})(10^3 \times 10^{-4} \text{ T})} = 10 \text{ V}$

10. Two isolated metallic solid spheres of radii  $R$  and  $2R$  are charged such that both have same charge density  $\sigma$ . The spheres are then connected by a thin conducting wire. If the new charge density of the bigger sphere is  $\sigma'$ . The ratio  $\frac{\sigma'}{\sigma}$  is :

- (1)  $\frac{9}{4}$  (2)  $\frac{4}{3}$   
 (3)  $\frac{5}{3}$  (4)  $\frac{5}{6}$

Official Ans. by NTA (4)

Ans. (4)

Sol.

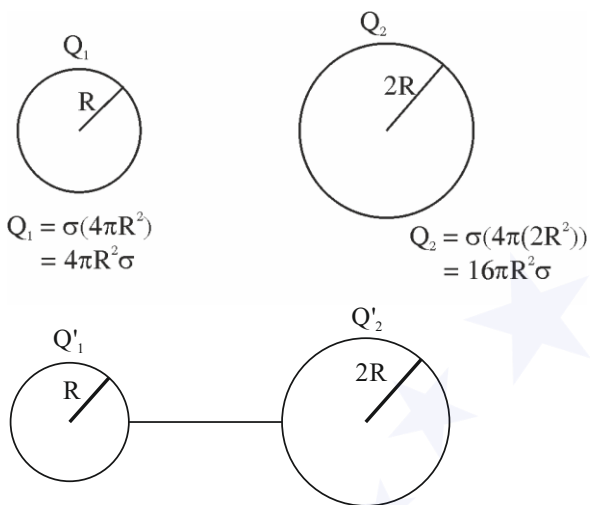

$$\frac{Q_1'}{4\pi\epsilon_0 R} = \frac{Q_2'}{4\pi\epsilon_0(2R)}$$

$$\therefore Q_2' = 2Q_1'$$

$$Q_1' + Q_2' = Q_1 + Q_2$$

$$\therefore \frac{Q_2'}{2} + Q_2' = 20\pi R^2\sigma$$

$$\frac{3}{2}Q_2' = 20\pi R^2\sigma$$

$$\therefore \frac{Q_2'}{4\pi(2R)^2} = \frac{2}{3} \cdot \frac{20\pi R^2\sigma}{16\pi R^2}$$

$$\therefore \frac{\sigma'}{\sigma} = \frac{5}{6}$$

11. Heat is given to an ideal gas in an isothermal process.

- A. Internal energy of the gas will decrease.  
 B. Internal energy of the gas will increase.  
 C. Internal energy of the gas will not change.  
 D. The gas will do positive work.  
 E. The gas will do negative work.

Choose the **correct** answer from the options given below :

- (1) A and E only (2) B and D only  
 (3) C and E only (4) C and D only

Official Ans. by NTA (4)

Ans. (4)

Sol.  $dQ = dU + dW \Rightarrow dU = nC_v dT$

$dU = 0$  (for isothermal)

$\therefore U = \text{constant}$

Also  $dQ > 0$  (supplied)

Hence  $dW > 0$

12. Electric field in a certain region is given by

$\vec{E} = \left( \frac{A}{x^2} \hat{i} + \frac{B}{y^3} \hat{j} \right)$ . The SI unit of A and B are :

- (1)  $\text{Nm}^3\text{C}^{-1}; \text{Nm}^2\text{C}^{-1}$  (2)  $\text{Nm}^2\text{C}^{-1}; \text{Nm}^3\text{C}^{-1}$   
 (3)  $\text{Nm}^3\text{C}; \text{Nm}^2\text{C}$  (4)  $\text{Nm}^2\text{C}; \text{Nm}^3\text{C}$

Official Ans. by NTA (2)

Ans. (2)

Sol.  $\vec{E} = \frac{A}{x^2} \hat{i} + \frac{B}{y^3} \hat{j}$

$\left[ \frac{A}{x^2} \right] = \text{NC}^{-1} \Rightarrow [A] = \text{Nm}^2\text{C}^{-1}$

$\left[ \frac{B}{y^3} \right] = \text{NC}^{-1} \Rightarrow [B] = \text{Nm}^3\text{C}^{-1}$

13. The output waveform of the given logical circuit for the following inputs A and B as shown below, is :

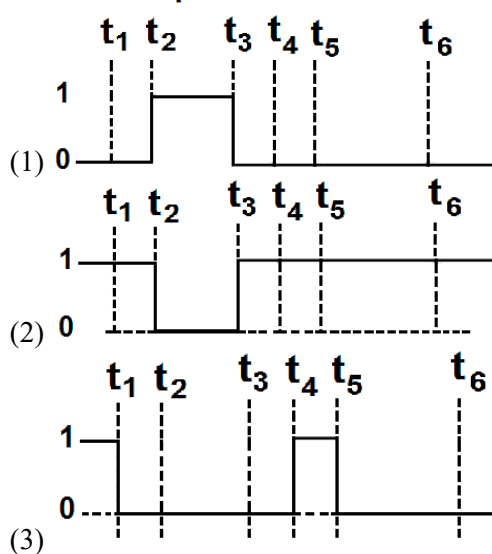
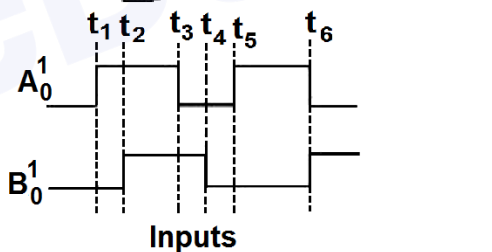
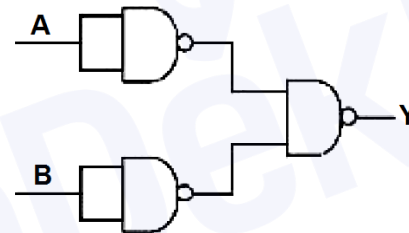

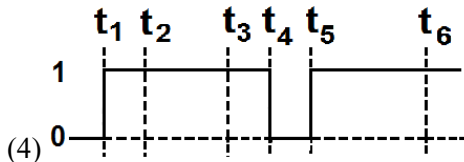

Official Ans. by NTA (4)

Ans. (4)

Sol.  $\overline{(\overline{A \cdot A})} = \overline{A}$   
 $\overline{(\overline{B \cdot B})} = \overline{B}$   
 $\overline{(\overline{A \cdot B})} = \overline{A + B}$

OR Gate

14. The height of liquid column raised in a capillary tube of certain radius when dipped in liquid A vertically is, 5 cm. If the tube is dipped in a similar manner in another liquid B of surface tension and density double the values of liquid A, the height of liquid column raised in liquid B would be \_\_\_\_\_ m.

- (1) 0.20 (2) 0.5  
 (3) 0.05 (4) 0.10

Official Ans. by NTA (3)

Ans. (3)

Sol.  $h = \frac{2S \cos \theta}{r \rho g}$

$\therefore \frac{h_1}{h_2} = \frac{S_1 \rho_2}{S_2 \rho_1}$

$\frac{h_1}{h_2} = \frac{1}{2} \implies h_2 = 5 \text{ cm} = 0.05 \text{ m}$

{Info about angle of contact not there so most appropriate is 3}

15. A sinusoidal carrier voltage is amplitude modulated. The resultant amplitude modulated wave has maximum and minimum amplitude of 120 V and 80 V respectively. The amplitude of each sideband is :

- (1) 15 V (2) 10 V  
 (3) 20 V (4) 5V

Official Ans. by NTA (2)

Ans. (2)

Sol.  $A_c + A_m = 120$

$A_c - A_m = 80$

$\therefore \frac{A_c}{A_m} = 100$

$A_m = 20$

Modulation index  $= \frac{20}{100} = \frac{1}{5}$

Amplitude of each sideband  
 $= A_c \frac{\text{ulation index}}{2}$

$= 100 \times \frac{1}{10} = 10 \text{ volt}$

16. In a series LR circuit with  $X_L = R$ . power factor is  $P_1$ . If a capacitor of capacitance  $C$  with  $X_C = X_L$  is added to the circuit the power factor becomes  $P_2$ . The ratio of  $P_1$  to  $P_2$  will be :

- (1) 1:3 (2)  $1:\sqrt{2}$   
 (3) 1:1 (4) 1:2

Official Ans. by NTA (2)

Ans. (2)

Sol.  $P = \frac{R}{Z} \implies P_1 = \frac{R}{\sqrt{R^2 + X_L^2}} = \frac{R}{R\sqrt{2}}$  (as  $X_L = R$ )

$P_1 = \frac{1}{\sqrt{2}}$

$P_2 = \frac{R}{\sqrt{R^2 + (X_L - X_C)^2}} = P_2 = 1$

$\frac{P_1}{P_2} = \frac{1}{\sqrt{2}}$

17. If the gravitational field in the space is given as

$\left(-\frac{K}{r^2}\right)$ . Taking the reference point to be at

$r = 2 \text{ cm}$  with gravitational potential  $V = 10 \text{ J/kg}$ . Find the gravitational potential at  $r = 3 \text{ cm}$  in SI unit (Given, that  $K = 6 \text{ J cm/kg}$ )

- (1) 9 (2) 11  
 (3) 12 (4) 10

Official Ans. by NTA (2)

Ans. (2)

Sol.  $-\frac{dV}{dr} = -\frac{k}{r^2} \implies \int_{10}^V dV = \int_2^3 \frac{k}{r^2} dr$

$V - 10 = k \left[ \frac{1}{2} - \frac{1}{3} \right]$

$V - 10 = \frac{k}{6} \implies V = 11 \text{ volts}$

18. A ball of mass 200 g rests on a vertical post of height 20 m. A bullet of mass 10 g, travelling in horizontal direction, hits the centre of the ball. After collision both travels independently. The ball hits the ground at a distance 30 m and the bullet at a distance of 120 m from the foot of the post. The value of initial velocity of the bullet will be (if  $g = 10 \text{ m/s}^2$ ) :

- (1) 120 m/s (2) 60 m/s  
 (3) 400 m/s (4) 360 m/s

Official Ans. by NTA (4)

Ans. (4)

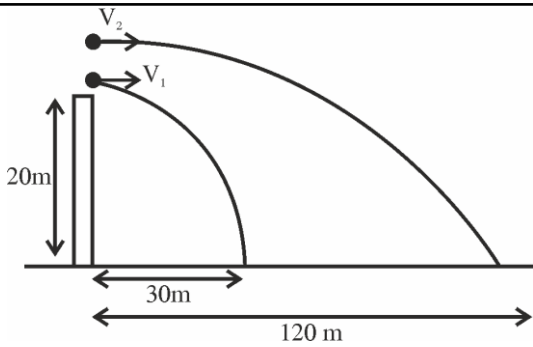

Sol.

$$v_1 = \frac{30}{\sqrt{\frac{2h}{g}}}, \quad v_2 = \frac{120}{\sqrt{\frac{2h}{g}}}$$

$$(0.01) u = (0.2) \frac{30\sqrt{g}}{\sqrt{2h}} + (0.01) \frac{120\sqrt{g}}{\sqrt{2h}}$$

$$u = 300 + 60 = 360 \text{ ms}^{-1}$$

19. Match Column-I with Column-II :

Column-I (x-t graphs)		Column-II (v-t graphs)	
A.		I.	
B.		II.	
C.		III.	
D.		IV.	

Choose the correct answer from the options given below:

- (1) A- II B-IV, C-III, D-I
- (2) A- I. B-II, C-III, D-IV
- (3) A- II B-III, C-IV, D-I
- (4) A- I, B-III. C-IV, D-II

Official Ans. by NTA (1)

Ans. (1)

Sol.  $\frac{dx}{dt} = \text{slope} \geq 0$  always increasing

(A - II)

$\frac{dx}{dt} < 0$ ; and at  $t \rightarrow \infty \frac{dx}{dt} \rightarrow 0$

(B - IV)

$\frac{dx}{dt} > 0$  for first half  $\frac{dx}{dt} < 0$  for second half.

(C - III)

$\frac{dx}{dt} = \text{constant}$

(D - I)

20. The figure represents the momentum time (p-t) curve for a particle moving along an axis under the influence of the force. Identify the regions on the graph where the magnitude of the force is maximum and minimum respectively ?

If  $(t_3 - t_2) < t_1$ .

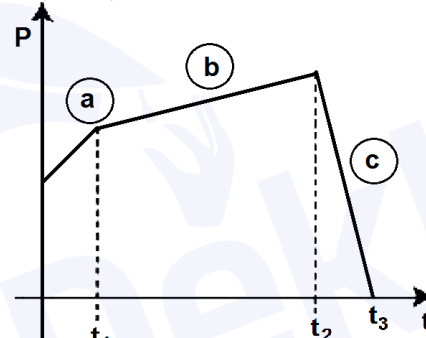

(1) c and a

(2) b and c

(3) c and b

(4) a and b

Official Ans. by NTA (3)

Ans. (3)

Sol.  $\left| \frac{d\vec{p}}{dt} \right| = |\vec{F}| \Rightarrow \frac{d\vec{p}}{dt} = \text{Slope of curve}$

max slope (c), min slope (b)

### SECTION-B

21. The general displacement of a simple harmonic oscillator is  $x = A \sin \omega t$ . Let T be its time period. The slope of its potential energy (U) - time (t) curve

will be maximum when  $t = \frac{T}{\beta}$ . The value of  $\beta$  is \_.

Official Ans. by NTA (8)

Ans. (8)

Sol.  $x = A \sin(\omega t)$

$$U_{(x)} = \frac{1}{2} kx^2,$$

$$\frac{dU}{dt} = \frac{1}{2} k 2x \frac{dx}{dt}$$

$$= kA^2 \omega \sin \omega t \cos \omega t \times \frac{2}{2}$$

$$\left( \frac{dU}{dt} \right)_{\max} = \frac{kA^2 \omega}{2} (\sin 2\omega t)_{\max}$$

$$2\omega t = \frac{\pi}{2} \Rightarrow t = \frac{\pi}{4\omega} = \frac{T}{8} \Rightarrow \beta = 8$$

22. A capacitor of capacitance  $900 \mu\text{F}$  is charged by a  $100 \text{ V}$  battery. The capacitor is disconnected from the battery and connected to another uncharged identical capacitor such that one plate of uncharged capacitor connected to positive plate and another plate of uncharged capacitor connected to negative plate of the charged capacitor. The loss of energy in this process is measured as  $x \times 10^{-2} \text{ J}$ . The value of  $x$  is \_\_\_\_\_.

Official Ans. by NTA (225)

\_\_\_\_\_ Ans. (225)

Sol.

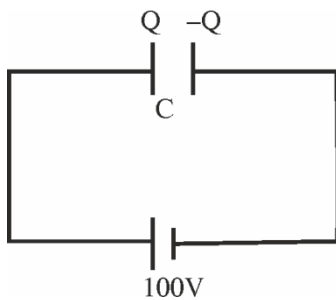

$$C = 900 \mu\text{F}$$

$$Q = CV = 900 \times 10^{-6} \times 100 = 9 \times 10^{-2} = 90 \text{ MC}$$

Now

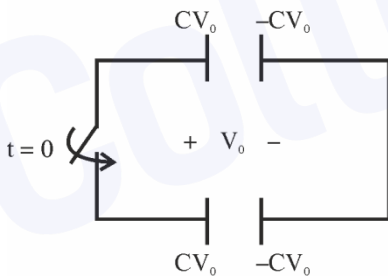
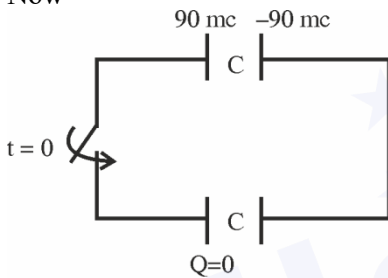

Common potential will be developed across both capacitors by kVL

Total charge on left plates of capacitors should be conserved.

$$\therefore 90 \text{ mc} + 0 = 2cv_0$$

$$cv_0 = 45 \text{ mc}$$

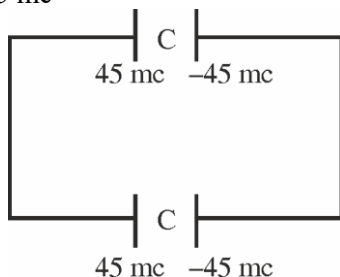

Heat dissipated =  $U_i - U_f$  [Change in energy stored in the capacitors]

$$= \frac{1}{2} \frac{(90 \text{ mc})^2}{900 \mu\text{F}} - 2 \times \frac{1}{2} \frac{(45 \text{ mc})^2}{900 \mu\text{F}} \left[ U = \frac{Q^2}{2c} \right]$$

$$= \frac{1}{2 \times 900 \times 10^{-6}} (8100 - 4050) \times 10^{-6}$$

$$= 2.25 \text{ Joule}$$

OR

$$\text{Heat} = \frac{1}{2} \frac{C_1 C_2}{C_1 + C_2} (V_1 - V_2)^2$$

$$= \frac{1}{2} \frac{C^2}{2C} (100 - 0)^2$$

$$= \frac{1}{2} \frac{900 \times 10^{-6}}{2} \times 10^4 = \frac{9}{4} \text{ Joule} = 2.25 \text{ Joule}$$

23. In Young's double slit experiment, two slits  $S_1$  and  $S_2$  are 'd' distance apart and the separation from slits to screen is D (as shown in figure). Now if two transparent slabs of equal thickness  $0.1 \text{ mm}$  but refractive index  $1.51$  and  $1.55$  are introduced in the path of beam ( $\lambda = 4000 \text{ \AA}$ ) from  $S_1$  and  $S_2$  respectively. The central bright fringe spot will shift by \_\_\_\_\_ number of fringes.

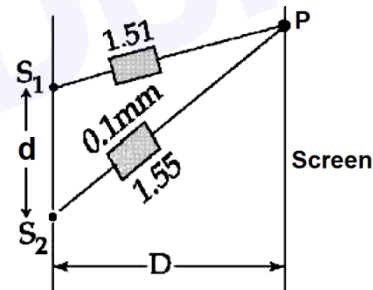

Official Ans. by NTA (10)

\_\_\_\_\_ Ans. (10)

Sol.

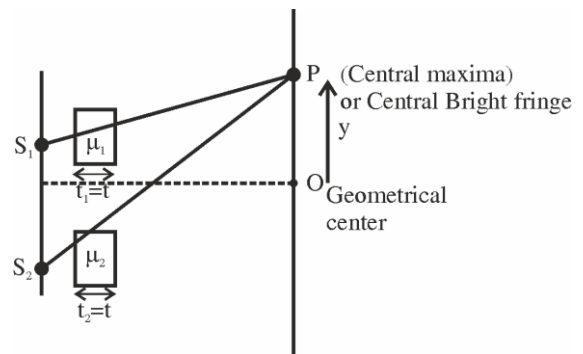

Path difference at P be  $\Delta x$

$$\Delta x = (\mu_2 - \mu_1)t$$

$$= (1.55 - 1.51) \cdot 0.1 \text{ mm}$$

$$= 0.04 \times 10^{-4}$$

$$\Delta x = 4 \times 10^{-6} = 4 \mu\text{m}$$

$$y = \frac{\Delta x D}{d} = 4 \times 10^{-6} \frac{D}{d}$$

{y is the distance of central maxima from geometric center}

$$\text{fringe width } (\beta) = \frac{\lambda D}{d} = 4 \times 10^{-6} \text{ m} \frac{D}{d} = 4 \mu\text{m} \frac{D}{d}$$

∴ Central bright fringe spot will shift by 'x'

$$\text{Number of shift} = \frac{y}{\beta}$$

$$= \frac{4 \times 10^{-6} D / d}{4 \times 10^{-7} D / d} = 10 \text{ Ans}$$

24. In the following circuit, the magnitude of current  $I_1$ , is \_\_\_\_\_ A.

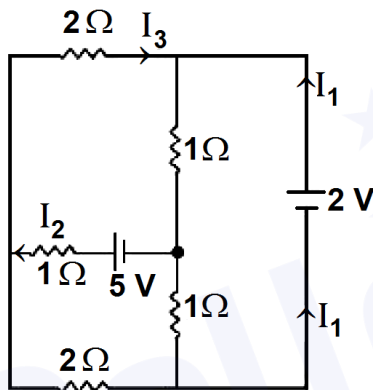

Official Ans. by NTA (1)

□ Ans. (1.5)

Sol.

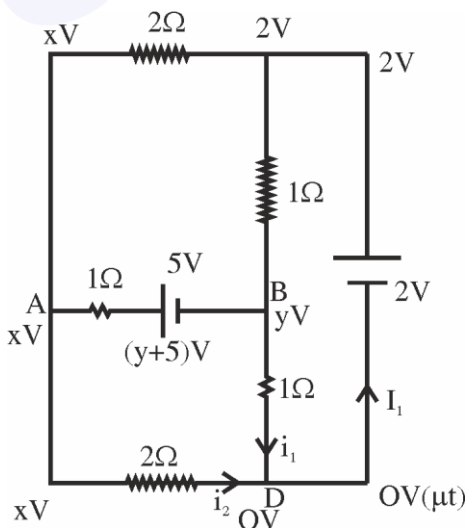

Junction law at A,

$$\frac{x - (y + 5)}{1} + \frac{x - 2}{2} + \frac{x - 0}{2} = 0 \quad \dots(1)$$

Junction law at B,

$$\frac{y + 5 - x}{1} + \frac{y - 0}{1} + \frac{y - 2}{1} = 0 \quad \dots(2)$$

On solving equation (1) and Equation (2)

$$x = 3$$

$$\& y = 0$$

At D junction

$$I_1 = i_1 + i_2$$

$$I_1 = \frac{y - 0}{1} + \frac{x - 0}{2}$$

$$= \frac{0 - 0}{1} + \frac{3 - 0}{2}$$

$$I_1 = 1.5 \text{ A}$$

25. A horse rider covers half the distance with 5 m/s speed. The remaining part of the distance was travelled with speed 10 m/s for half the time and with speed 15 m/s for other half of the time. The mean speed of the rider averaged over the whole time of motion is  $x/7$  m/s. The value of x is

Official Ans. by NTA (50)

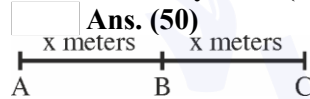

Sol.

$$t_{AB} = \frac{x}{5 \text{ m/s}}$$

In motion BC

$$x = d_1 + d_2$$

where  $d_1$  &  $d_2$  we the distance travelled with 10 m/s and 15 m/s respectively in equal time intervals

$$\frac{t}{2} \text{ each}$$

$$d_1 = \frac{10t}{2}, d_2 = \frac{15t}{2}$$

$$d_1 + d_2 = x = \frac{t}{2}(10 + 15) = \frac{25t}{2}$$

$$\langle v \rangle = \frac{2x}{\frac{x}{5} + \frac{2x}{25}} = \frac{2 \times 25}{5 + 2} = \frac{50}{7} \text{ m/s}$$

Ans. : 50

26. A point source of light is placed at the centre of curvature of a hemispherical surface. The source emits a power of 24 W The radius of curvature of hemisphere is 10 cm and the inner surface is completely reflecting. The force on the hemisphere due to the light falling on it is \_\_\_\_\_  $\times 10^{-8}$  N.

Official Ans. by NTA (4)

Ans. (4)

Sol.

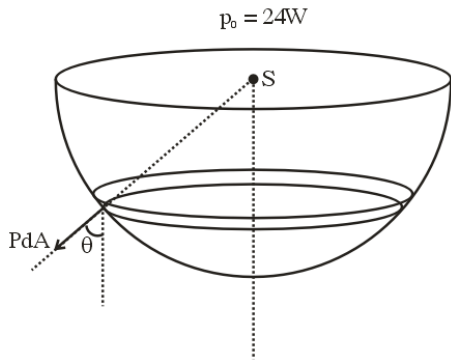

$$\begin{aligned} \text{Force} &= \int PdA \cos \theta \\ &= \frac{2I}{C} \int dA \cos \theta = \frac{2I}{C} \pi R^2 = 2 \frac{p_0}{4\pi R^2} \cdot \frac{\pi R^2}{C} \\ &= \frac{p_0}{2C} = \frac{24}{2 \times 3 \times 10^8} = 4 \times 10^{-8} \text{ N (Ans)} \end{aligned}$$

27. As per the given figure, if  $\frac{dI}{dt} = -1 \text{ A/s}$  then the value of  $V_{AB}$  at this instant will be \_\_\_\_\_ V.

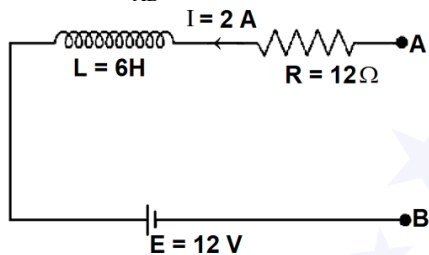

Official Ans. by NTA (30)  
 Ans. (30)

Sol.

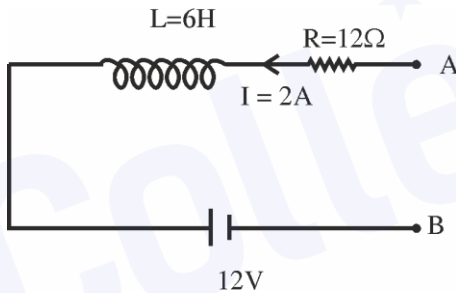

$$\frac{dI}{dt} = -1 \frac{\text{A}}{\text{sec}}$$

$$V_A - IR - L \frac{dI}{dt} - 12 = V_B$$

$$V_A - 2 \times 12 - 6(-1) - 12 = V_B$$

$$V_A - V_B = 36 - 6 = 30 \text{ volt}$$

28. In a screw gauge, there are 100 divisions on the circular scale and the main scale moves by 0.5 mm on a complete rotation of the circular scale. The zero of circular scale lies 6 divisions below the line of graduation when two studs are brought in contact with each other. When a wire is placed between the studs, 4 linear scale divisions are clearly visible while 46<sup>th</sup> division the circular scale coincide with the reference line. The diameter of the wire is \_\_\_\_\_  $\times 10^{-2}$  mm.

Official Ans. by NTA (22)  
 Ans. (220)

Sol. Least count =  $\frac{\text{Pitch}}{\text{No. of circular divisions}}$

$$= \frac{0.5 \text{ mm}}{100}$$

$$\text{Least count} = 5 \times 10^{-3} \text{ mm}$$

$$\text{Positive Error} = \text{MSR} + \text{CSR (LC)}$$

$$= 0 \text{ mm} + 6(5 \times 10^{-3} \text{ mm})$$

$$\text{Reading of Diameter} = \text{MSR} + \text{CSR (LC)} - \text{Positive zero error}$$

$$= 4 \times 0.5 \text{ mm} + (46(5 \times 10^{-3})) - 6(5 \times 10^{-3}) \text{ mm}$$

$$= 2 \text{ mm} + 40 \times 5 \times 10^{-3} \text{ mm} = 2.2 \text{ mm (Ans.)}$$

29. In an experiment for estimating the value of focal length of converging mirror, image of an object placed at 40 cm from the pole of the mirror is formed at distance 120 cm from the pole of the mirror. These distances are measured with a modified scale in which there are 20 small divisions in 1 cm. The value of error in measurement of focal length of the mirror is 1/K cm. The value of K is \_\_\_\_\_.

Official Ans. by NTA (32)

Ans. (32)

Sol.  $\frac{1}{v} + \frac{1}{u} = \frac{1}{f}$

$$\frac{-1}{120} - \frac{1}{40} = \frac{1}{f}, \quad f = -30 \text{ cm}$$

Now,

$$\frac{-1}{v^2} dv - \frac{1}{u^2} du = -\frac{1}{f^2} df$$

$$\text{Also } dv = du = \frac{1}{20} \text{ cm}$$

$$\therefore \frac{1}{(120)^2} + \frac{1}{(40)^2} = \frac{df}{(30)^2}$$

On solving

$$df = \frac{1}{32} \text{ cm}$$

$$\therefore k = 32$$

30. A thin uniform rod of length 2m. cross sectional area 'A' and density 'd' is rotated about an axis passing through the centre and perpendicular to its length with angular velocity  $\omega$ . If value of  $\omega$  in

terms of its rotational kinetic energy E is  $\sqrt{\frac{\alpha E}{Ad}}$

then the value of  $\alpha$  is \_\_\_\_\_.

Official Ans. by NTA (3)

Ans. (3)



**Sol.**  $(KE)_{\text{Rotational}} = \frac{1}{2} I \omega^2 = E$

$$E = \frac{1}{2} \frac{m \ell^2}{12} \omega^2$$

$$E = \frac{1}{2} \frac{dA \ell^3}{12} \omega^2$$

$$E = \frac{dA (2)^3}{24} \omega^2$$

$$\sqrt{\frac{3E}{dA}} = \omega$$

$$\alpha = 3 \text{ Ans.}$$