

# FINAL JEE–MAIN EXAMINATION – JANUARY, 2023

(Held On Tuesday 31<sup>st</sup> January, 2023)

TIME : 9 : 00 AM to 12 : 00 NOON

## SECTION-A

1. A bar magnet with a magnetic moment  $5.0 \text{ Am}^2$  is placed in parallel position relative to a magnetic field of  $0.4 \text{ T}$ . The amount of required work done in turning the magnet from parallel to antiparallel position relative to the field direction is \_\_\_\_\_.

- (1) 4 J                                      (2) 1 J  
(3) 2 J                                      (4) Zero

**Official Ans. by NTA (1)**

**Ans. (1)**

**Sol.**  $u = -MB \cos\theta$

$$W = \Delta u$$

$$W = -MB \cos 180^\circ - (-mB \cos 0^\circ)$$

$$W = 2MB = 2 \times 5 \times 0.4 = 4\text{J}$$

Option 1

2. If a source of electromagnetic radiation having power  $15 \text{ kW}$  produces  $10^{16}$  photons per second, the radiation belongs to a part of spectrum is.

(Take Planck constant  $h = 6 \times 10^{-34} \text{ Js}$ )

- (1) Micro waves  
(2) Ultraviolet rays  
(3) Gamma rays  
(4) Radio waves

**Official Ans. by NTA (3)**

**Ans. (3)**

**Sol.** Energy of one photon =  $\frac{\text{Power}}{\text{Photon frequency}}$

$$E = hv = \frac{15 \times 10^3}{10^{16}}$$

$$v = \frac{15 \times 10^{-13}}{6 \times 10^{-34}} = 2.5 \times 10^{21}$$

So gamma Rays. Option 3

3. The amplitude of  $15\sin(1000\pi t)$  is modulated by  $10\sin(4\pi t)$  signal. The amplitude modulated signal contains frequency(ies) of

- (A) 500 Hz  
(B) 2 Hz  
(C) 250 Hz  
(D) 498 Hz  
(E) 502 Hz

Choose the correct answer from the options given below:

- (1) A only  
(2) A, D and E only  
(3) B only  
(4) A and B only

**Official Ans. by NTA (2)**

**Ans. (2)**

**Sol.** Carrier wave frequency

$$V_c = \frac{100\pi}{2\pi} = 500 \text{ Hz}$$

Modulating wave frequency

$$V_m = \frac{4\pi}{2\pi} = 2 \text{ Hz}$$

$$\therefore V_c - V_m, V_c, V_c + V_m \\ = 498 \text{ Hz}, 500 \text{ Hz}, 502 \text{ Hz.}$$

4. As shown in figure, a  $70 \text{ kg}$  garden roller is pushed with a force of  $\vec{F} = 200 \text{ N}$  at an angle of  $30^\circ$  with horizontal. The normal reaction on the roller is (Given  $g = 10 \text{ m s}^{-2}$ )

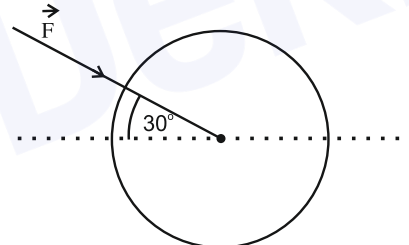

(1)  $800\sqrt{2} \text{ N}$

(2)  $600 \text{ N}$

(3)  $800 \text{ N}$

(4)  $200\sqrt{3} \text{ N}$

**Official Ans. by NTA (3)**

**Ans. (3)**

**Sol.**

$$N = mg + F \sin 30^\circ \\ = 700 + 200 \times \frac{1}{2} = 800 \text{ newton.}$$

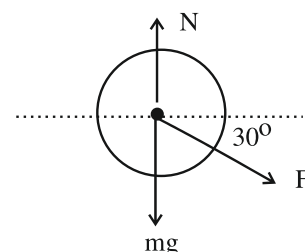

5. The initial speed of a projectile fired from ground is  $u$ . At the highest point during its motion, the speed of projectile is  $\frac{\sqrt{3}}{2}u$ . The time of flight of the projectile is:

- (1)  $\frac{u}{2g}$                       (2)  $\frac{u}{g}$   
 (3)  $\frac{2u}{g}$                       (4)  $\frac{\sqrt{3}u}{g}$

**Official Ans. by NTA (2)**

**Ans. (2)**

**Sol.**  $u \cos \theta = \frac{\sqrt{3}u}{2} \Rightarrow \cos \theta = \frac{\sqrt{3}}{2}$

$\Rightarrow \theta = 30^\circ$

$T = \frac{2u \sin 30^\circ}{g} = \frac{u}{g}$

Option 2.

6. Spherical insulating ball and a spherical metallic ball of same size and mass are dropped from the same height. Choose the correct statement out of the following {Assume negligible air friction}

- (1) Time taken by them to reach the earth's surface will be independent of the properties of their materials  
 (2) Insulating ball will reach the earth's surface earlier than the metal ball  
 (3) Both will reach the earth's surface simultaneously  
 (4) Metal ball will reach the earth's surface earlier than the insulating ball.

**Official Ans. by NTA (2)**

**Ans. (2)**

**Sol.** When metal is passing through magnetic field, eddy current will produce and it will oppose the motion, so it will take more time.

7. A free neutron decays into a proton but a free proton does not decay into neutron. This is because  
 (1) neutron is an uncharged particle  
 (2) proton is a charged particle  
 (3) neutron is a composite particle made of a proton and an electron  
 (4) neutron has larger rest mass than proton

**Official Ans. by NTA (4)**

**Ans. (4)**

**Sol.** As neutron has more rest mass than proton it will require energy to decay proton into neutron.

Option 4.

8. The effect of increase in temperature on the number of electrons in conduction band ( $n_c$ ) and resistance of a semiconductor will be as:

- (1) Both  $n_c$  and resistance decrease  
 (2) Both  $n_c$  and resistance increase  
 (3)  $n_c$  increases, resistance decreases  
 (4)  $n_c$  decreases, resistance increases

**Official Ans. by NTA (3)**

**Ans. (3)**

**Sol.** As temperature increases, more electron excite to conduction band and hence conductivity increases, therefore resistance decreases.

9. The maximum potential energy of a block executing simple harmonic motion is 25 J. A is amplitude of oscillation. At  $\frac{A}{2}$ , the kinetic energy of the block is

- (1) 37.5 J                      (2) 9.75 J  
 (3) 18.75 J                      (4) 12.5 J

**Official Ans. by NTA (3)**

**Ans. (3)**

**Sol.**  $u_{\max} = \frac{1}{2} m \omega^2 A^2 = 25 \text{ J}$

KE at  $\frac{A}{2} = \frac{1}{2} m v_1^2 = \frac{1}{2} m \omega^2 \left( A^2 - \frac{A^2}{4} \right)$

KE =  $\frac{1}{2} m \omega^2 \frac{3A^2}{4} = \frac{3}{4} \left( \frac{1}{2} m \omega^2 A^2 \right)$

KE =  $\frac{3}{4} \times 25 = 18.75 \text{ J}$

10. The pressure of a gas changes linearly with volume from A to B as shown in figure. If no heat is supplied to or extracted from the gas then change in the internal energy of the gas will be

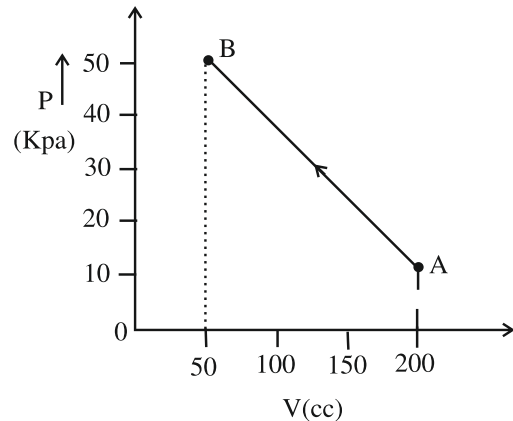

- (1) 6 J                              (2) Zero  
 (3) -4.5 J                              (4) 4.5 J

**Official Ans. by NTA (4)**

**Ans. (4)**

Sol. As  $\Delta q = 0$

$$\Delta u = -W$$

$$W = \int PdV$$

$$\Delta u = -W = 30 \times 10^3 \times 150 \times 10^{-6}$$

$$= 4500 \times 10^{-3}$$

$$= 4.5 \text{ J}$$

11. Which of the following correctly represents the variation of electric potential (V) of a charged spherical conductor of radius (R) with radial distance (r) from the centre?

(1)

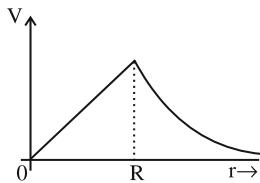

(2)

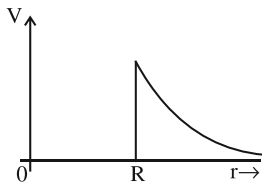

(3)

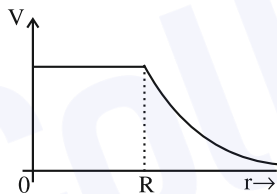

(4)

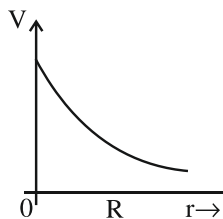

Official Ans. by NTA (3)

Ans. (3)

Sol. Conceptual

12. Given below are two statements: One is labelled as **Assertion A** and the other is labelled as **Reason R**  
**Assertion A:** The beam of electrons shows wave nature and exhibit interference and diffraction.  
**Reason R :** Davisson Germer Experimentally verified the wave nature of electrons.

In the light of the above statements. Choose the **most appropriate** answer from the options given below :

- (1) A is correct but R is not correct
- (2) A is not correct but R is correct
- (3) Both A and R are correct but R is Not the correct explanation of A
- (4) Both A and R are correct and R is the correct explanation of A

Official Ans. by NTA (4)

Ans. (4)

Sol. Conceptual

13. The drift velocity of electrons for a conductor connected in an electrical circuit is  $V_d$ . The conductor is now replaced by another conductor with same material and same length but double the area of cross section. The applied voltage remains same. The new drift velocity of electrons will be

- (1)  $V_d$
- (2)  $\frac{V_d}{2}$
- (3)  $\frac{V_d}{4}$
- (4)  $2V_d$

Official Ans. by NTA (1)

Ans. (1)

Sol.  $V_d = \frac{eE}{m} \tau$  that is independent of area

14. At a certain depth "d" below surface of earth. value of acceleration due to gravity becomes four times that of its value at a height 3R above earth surface. Where R is Radius of earth (Take  $R = 6400 \text{ km}$ ). The depth d is equal to

- (1) 5260 km
- (2) 640 km
- (3) 2560 km
- (4) 4800 km

Official Ans. by NTA (4)

Ans. (4)

Sol.  $\frac{GM}{R^2} \left[ 1 - \frac{d}{R} \right] = \frac{4 \times GM}{(4R)^2}$

$$1 - \frac{d}{R} = \frac{1}{4} \Rightarrow \frac{d}{R} = \frac{3}{4} \Rightarrow d = \frac{3}{4}R$$

$$d = 4800 \text{ km}$$

15. If 1000 droplets of water of surface tension 0.07 N/m. having same radius 1 mm each, combine to form a single drop. In the process the released surface energy is-

(Take  $\pi = \frac{22}{7}$ )

- (1)  $7.92 \times 10^{-6} \text{ J}$
- (2)  $7.92 \times 10^{-4} \text{ J}$
- (3)  $9.68 \times 10^{-4} \text{ J}$
- (4)  $8.8 \times 10^{-5} \text{ J}$

Official Ans. by NTA (2)

Ans. (2)

Sol.  $1000 \times \frac{4\pi}{3} (1)^3 = \frac{4\pi}{3} R^3$

$$R = 10 \text{ mm}$$

$$T \times 1000 \times 4\pi (10^{-3})^2 - T \times 4\pi (10 \times 10^{-3})^2 = \Delta E$$

$$\Delta E = 4 \times \pi \times 7 \times 10^{-2} [1000 - 100] \times 10^{-6}$$

$$\Delta E = 7.92 \times 10^{-4} \text{ J}$$

Option 2.

16. A rod with circular cross-section area  $2 \text{ cm}^2$  and length  $40 \text{ cm}$  is wound uniformly with 400 turns of an insulated wire. If a current of  $0.4 \text{ A}$  flows in the wire windings, the total magnetic flux produced inside windings is  $4\pi \times 10^{-6} \text{ Wb}$ . The relative permeability of the rod is

(Given : Permeability of vacuum

$$\mu_0 = 4\pi \times 10^{-7} \text{ NA}^{-2})$$

- (1) 12.5
- (2)  $\frac{32}{5}$
- (3) 125
- (4)  $\frac{1}{16}$

Official Ans. by NTA (3)

Ans. (3)

Sol.  $\phi = \mu_r \mu_0 \frac{N}{\ell} I \times A$

$$\mu_r = 125$$

Option 3.

17. The correct relation between  $\gamma = \frac{C_p}{C_v}$  and temperature T is :

- (1)  $\gamma \propto \frac{1}{\sqrt{T}}$
- (2)  $\gamma \propto T^\circ$
- (3)  $\gamma \propto \frac{1}{T}$
- (4)  $\gamma \propto T$

Official Ans. by NTA (2)

Ans. (2)

- Sol.  $\gamma$  is independent of temperature

Option 2

18. Two polaroids A and B are placed in such a way that the pass-axis of polaroids are perpendicular to each other. Now, another polaroid C is placed between A and B bisecting angle between them. If intensity of unpolarised light is  $I_0$  then intensity of transmitted light after passing through polaroid B will be :

- (1)  $\frac{I_0}{4}$
- (2)  $\frac{I_0}{2}$
- (3)  $\frac{I_0}{8}$
- (4) Zero

Official Ans. by NTA (3)

Ans. (3)

Sol.  $I_A = \frac{I_0}{2}$

$$I_C = \frac{I_0}{2} \cos^2 45 = \frac{I_0}{4}$$

$$I_B = I_C \cos^2 45 = \frac{I_0}{8}$$

Option 3.

19. If R,  $X_L$  and  $X_C$  represent resistance, inductive reactance and capacitive reactance. Then which of the following is dimensionless:

- (1)  $R X_L X_C$
- (2)  $\frac{R}{\sqrt{X_L X_C}}$
- (3)  $\frac{R}{X_L X_C}$
- (4)  $R \frac{X_L}{X_C}$

Official Ans. by NTA (2)

Ans. (2)

Sol. All three have same dimension therefore  $\frac{R}{\sqrt{X_L X_C}}$

is dimensionless.

Option 2

20. 100 balls each of mass  $m$  moving with speed  $v$  simultaneously strike a wall normally and reflected back with same speed, in time  $t$  s. The total force exerted by the balls on the wall is

- (1)  $\frac{100mv}{t}$  (2)  $\frac{200mv}{t}$   
 (3)  $200 mvt$  (4)  $\frac{mv}{100t}$

Official Ans. by NTA (2)

Ans. (2)

Sol.  $P_i = Nmv \hat{i}$   $\vec{P}_f = -Nmv \hat{i}$

$N$  is Number of balls strikes with wall

$N = 100$

$$\Delta \vec{P} = \vec{P}_f - \vec{P}_i = -2Nmv \hat{i}$$

$$= -200 Nmv \hat{i}$$

$$\vec{F}_{\text{Total}} = \frac{\Delta \vec{P}}{\Delta t} = -\frac{200mvt}{t}$$

$$|\vec{F}| = \frac{200mv}{t}$$

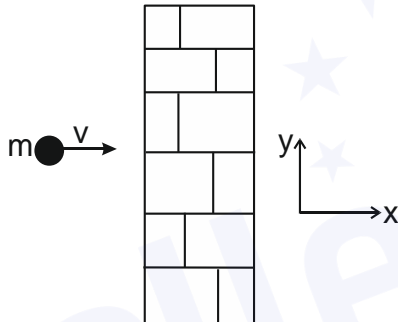

SECTION-B

21. A thin rod having a length of 1 m and area of cross-section  $3 \times 10^{-6} \text{ m}^2$  is suspended vertically from one end. The rod is cooled from  $210^\circ\text{C}$  to  $160^\circ\text{C}$ . After cooling, a mass  $M$  is attached at the lower end of the rod such that the length of rod again becomes 1 m. Young's modulus and coefficient of linear expansion of the rod are  $2 \times 10^{11} \text{ Nm}^{-2}$  and  $2 \times 10^{-5} \text{ K}^{-1}$ , respectively. The value of  $M$  is \_\_\_\_\_ kg. (Take  $g = 10 \text{ m s}^{-2}$ )

Official Ans. by NTA (60)

Ans. (60)

Sol. If  $\Delta \ell$  is decrease in length of rod due to decrease in temperature

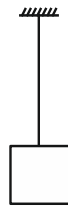

$$\Delta \ell = \ell \alpha \Delta T$$

$$\alpha = 2 \times 10^{-5} \text{ K}^{-1}, \Delta T = (210 - 160)$$

$$= 50 \text{ K}$$

$$\Delta \ell = 1 \times 2 \times 10^{-5} \times 50 = 10^{-3} \text{ m}$$

$$\text{Young Modulus} = Y = \frac{F/A}{\Delta \ell / \ell} \quad A = 3 \times 10^{-6} \text{ m}^2$$

$$2 \times 10^{11} = \frac{Mg / 3 \times 10^{-6}}{10^{-3} / 1}$$

$$Mg = 2 \times 10^{11} \times 3 \times 10^{-9} = 6 \times 10^2$$

$$M = 60 \text{ kg}$$

Ans is 60.

22. The speed of a swimmer is  $4 \text{ km h}^{-1}$  in still water. If the swimmer makes his strokes normal to the flow of river of width 1 km, he reaches a point 750 m down the stream on the opposite bank.

The speed of the river water is \_\_\_\_\_  $\text{km h}^{-1}$ .

Official Ans. by NTA (3)

Ans. (3)

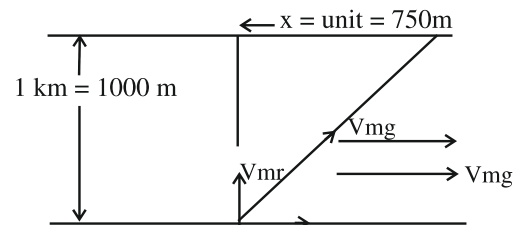

Sol.

time to cross the River width  $\omega = 1000 \text{ m}$

$$\text{is} = \frac{1 \text{ km}}{4 \text{ km / h}}$$

$$\text{Drift } x = Vm/g \times t$$

Where  $Vm/g$  is velocity of River w.r. to ground.

$$x = Vm / g \times \frac{1}{4} = 750m = \frac{3}{4} \text{ km}$$

$$Vm / g = 3 \text{ km / hr}$$

Ans is 3 km/hr.

23. In the figure given below. a block of mass  $M = 490 \text{ g}$  placed on a frictionless table is connected with two springs having same spring constant ( $K = 2 \text{ N m}^{-1}$ ). If the block is horizontally displaced through 'X'm then the number of complete oscillations it will make in  $14\pi$  seconds will be \_\_\_\_\_

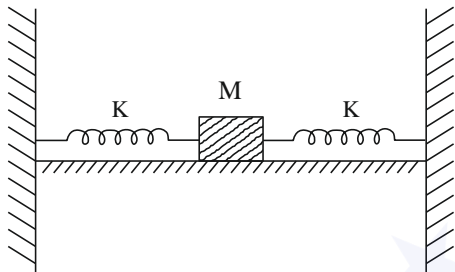

Official Ans. by NTA (20)

Ans. (20)

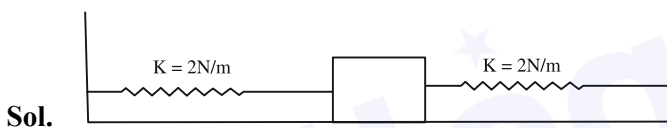

Sol.

$K_{\text{eff}} = K + K$  as both springs are in use in parallel

$$= 2k$$

$$= 2 \times 2 = 4 \text{ N/m}$$

$$m = 490 \text{ gm}$$

$$= 0.49 \text{ kg}$$

$$T = 2\pi \sqrt{\frac{m}{K_{\text{eff}}}} = 2\pi \sqrt{\frac{0.49 \text{ kg}}{4}}$$

$$= \sqrt{\frac{49}{0}} = 2\pi \frac{7}{20} = \frac{7\pi}{10}$$

No. of oscillation in the  $14\pi$  is

$$N = \frac{\text{time}}{T} = \frac{14\pi}{7\pi/10} = 20$$

Ans in 20.

24. In a medium the speed of light wave decreases to 0.2 times to its speed in free space The ratio of relative permittivity to the refractive index of the medium is  $x : 1$ . The value of  $x$  is \_\_\_\_\_.

(Given speed of light in free space  $= 3 \times 10^8 \text{ m s}^{-1}$  and for the given medium  $\mu_r = 1$ )

Official Ans. by NTA (5)

Ans. (5)

$$\text{Sol. } V = \frac{C}{\mu} \Rightarrow \mu = \frac{C}{V} = \frac{C}{0.2C}$$

$$\mu = 5$$

$$\mu = \sqrt{\epsilon_r \mu_r}$$

$$\Rightarrow \epsilon_r = \frac{\mu^2}{\mu_r}$$

$$\therefore \frac{\epsilon_r}{\mu} = \frac{\mu}{\mu_r} = 5$$

25. A solid sphere of mass 1 kg rolls without slipping on a plane surface. Its kinetic energy is  $7 \times 10^{-3} \text{ J}$ . The speed of the centre of mass of the sphere is \_\_\_\_\_  $\text{cm s}^{-1}$ .

Official Ans. by NTA (10)

Ans. (10)

$$\text{Sol. } \frac{1}{2}mv^2 + \frac{1}{2}I\omega^2 = 7 \times 10^{-3}$$

$$\frac{1}{2}mv^2 + \frac{1}{2} \left( \frac{2}{5}MR^2 \right) \left( \frac{V}{R} \right)^2 = 7 \times 10^{-3}$$

$$\frac{1}{2}MV^2 \left[ 1 + \frac{2}{5} \right] = 7 \times 10^{-3}$$

$$\frac{1}{2}(1)(V^2) \left( \frac{7}{5} \right) = 7 \times 10^{-3}$$

$$V^2 = 10^{-2}$$

$$V = 10^{-1} = 0.1 \text{ m / s} = 10 \text{ cm/s}$$

Ans : 10

26. An inductor of 0.5 mH, a capacitor of 20  $\mu\text{F}$  and resistance of 20  $\Omega$  are connected in series with a 220 V ac source. If the current is in phase with the emf, the amplitude of current of the circuit is  $\sqrt{x}$  A. The value of x is -

Official Ans. by NTA (242)

Ans. (242)

Sol.  $X_L = X_C$

So,  $Z = R = 20 \Omega$

$$i_{\text{rms}} = \frac{220}{20} = 11$$

$$i_{\text{max}} = 11\sqrt{2} = \sqrt{242}$$

Ans : 242

27. Expression for an electric field is given by

$\vec{E} = 4000x^2\hat{i} \frac{\text{V}}{\text{m}}$ . The electric flux through the

cube of side 20 cm when placed in electric field (as shown in the figure) is \_\_\_\_\_ V cm.

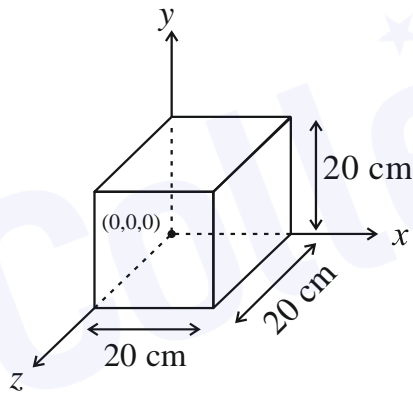

Official Ans. by NTA (640)

Ans. (640)

Sol. Flux =  $\vec{E} \cdot \vec{A}$

$$= 4000 (0.2)^2 \frac{\text{V}}{\text{m}} \cdot (0.2)^2 \text{m}^2$$

$$= 4000 \times 16 \times 10^{-4} \text{Vm}$$

$$= 640 \text{Vcm}$$

Ans. 640

28. A lift of mass  $M = 500 \text{ kg}$  is descending with speed of  $2 \text{ ms}^{-1}$ . Its supporting cable begins to slip thus allowing it to fall with a constant acceleration of  $2 \text{ ms}^{-2}$ . The kinetic energy of the lift at the end of fall through to a distance of 6 m will be \_\_\_\_\_ kJ.

Official Ans. by NTA (7)

Ans. (7)

Sol.  $v^2 = u^2 + 2as$

$$= 2^2 + 2(2)(6)$$

$$= 4 + 24 = 28$$

$$\text{KE} = \frac{1}{2}mv^2$$

$$= \frac{1}{2}(500)28$$

$$= 7000 \text{ J}$$

$$= 7 \text{ kJ}$$

Ans. 7

29. For hydrogen atom,  $\lambda_1$  and  $\lambda_2$  are the wavelengths corresponding to the transitions 1 and 2 respectively as shown in figure. The ratio of  $\lambda_1$  and

$\lambda_2$  is  $\frac{x}{32}$ . The value of x is \_\_\_\_\_.

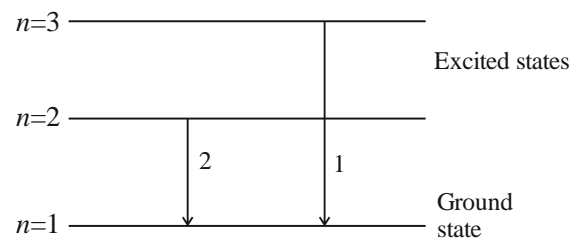

Official Ans. by NTA (27)

Ans. (27)

Sol.  $\frac{1}{\lambda} = Rz^2 \left[ \frac{1}{n_1^2} - \frac{1}{n_2^2} \right]$

$$\frac{1}{\lambda_1} = Rz^2 \left[ \frac{1}{1^2} - \frac{1}{3^2} \right] = \frac{8}{9}Rz^2 \quad \dots\dots\dots (1)$$

$$\frac{1}{\lambda_2} = Rz^2 \left[ \frac{1}{1^2} - \frac{1}{2^2} \right] = \frac{3}{4}Rz^2 \quad \dots\dots\dots (2)$$

$$\frac{1}{2} \Rightarrow \frac{\lambda_2}{\lambda_1} = \frac{8}{9} \times \frac{4}{3} = \frac{32}{27}$$

$$\frac{\lambda_1}{\lambda_2} = \frac{27}{32}$$

Ans. 27

30. Two identical cells, when connected either in parallel or in series gives same current in an external resistance  $5\Omega$ . The internal resistance of each cell will be \_\_\_\_\_  $\Omega$ .

Official Ans. by NTA (5)

Ans. (5)

Sol. Parallel

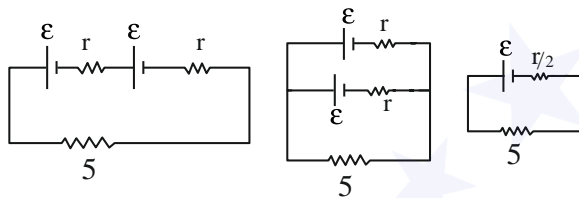

$$i = \frac{2\varepsilon}{5 + 2r} \dots (1)$$

$$i = \frac{\varepsilon}{\frac{r}{2} + 5} \dots (2)$$

Equating (1) and (2)

$$\frac{2\varepsilon}{5 + 2r} = \frac{\varepsilon}{5} \Rightarrow r + 10 = 5 + 2r$$

r = 5 Ans. 5