

PHYSICS

SECTION-A

1. A cube is placed inside an electric field, $\vec{E} = 150y^2\hat{j}$. The side of the cube is 0.5 m and is placed in the field as shown in the given figure. The charge inside the cube is :

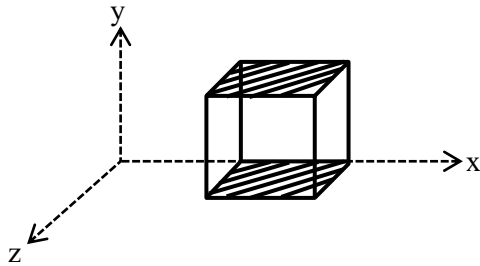

- (1) $3.8 \times 10^{-11} \text{ C}$ (2) $8.3 \times 10^{-11} \text{ C}$
 (3) $3.8 \times 10^{-12} \text{ C}$ (4) $8.3 \times 10^{-12} \text{ C}$

Official Ans. by NTA (2)

Sol. As electric field is in y-direction so electric flux is only due to top and bottom surface

Bottom surface $y = 0$

$\Rightarrow E = 0 \Rightarrow \phi = 0$

Top surface $y = 0.5 \text{ m}$

$\Rightarrow E = 150 (.5)^2 = \frac{150}{4}$

Now flux $\phi = EA = \frac{150}{4} (.5)^2 = \frac{150}{16}$

By Gauss's law $\phi = \frac{Q_{in}}{\epsilon_0}$

$\frac{150}{16} = \frac{Q_{in}}{\epsilon_0}$

$Q_{in} = \frac{150}{16} \times 8.85 \times 10^{-12} = 8.3 \times 10^{-11} \text{ C}$

Option (2)

2. A square loop of side 20 cm and resistance 1Ω is moved towards right with a constant speed v_0 . The right arm of the loop is in a uniform magnetic field of 5T. The field is perpendicular to the plane of the loop and is going into it. The loop is connected to a network of resistors each of value 4Ω . What should be the value of v_0 so that a steady current of 2 mA flows in the loop ?

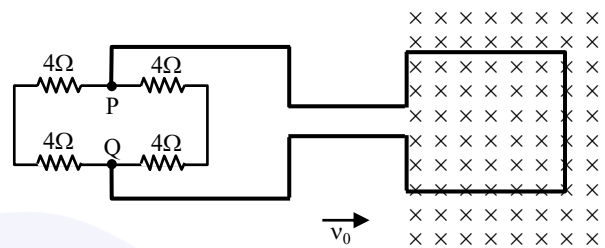

- (1) 1 m/s (2) 1 cm/s
 (3) 10^2 m/s (4) 10^{-2} cm/s

Official Ans. by NTA (2)

Sol. Equivalent circuit

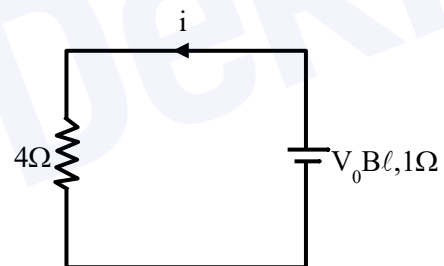

$i = \frac{V_0 B l}{4 + 1} \Rightarrow V_0 = \frac{5(2\text{mA})}{5 \times 2} = 10^{-2} \text{ m/s} = 1 \text{ cm/s}$

Option (2)

3. The temperature of an ideal gas in 3-dimensions is 300 K. The corresponding de-Broglie wavelength of the electron approximately at 300 K, is :

$[m_e = \text{mass of electron} = 9 \times 10^{-31} \text{ kg}]$

$h = \text{Planck constant} = 6.6 \times 10^{-34} \text{ Js}$

$k_B = \text{Boltzmann constant} = 1.38 \times 10^{-23} \text{ JK}^{-1}]$

- (1) 6.26 nm (2) 8.46 nm
 (3) 2.26 nm (4) 3.25 nm

Official Ans. by NTA (1)

Sol. De-Broglie wavelength

$$\lambda = \frac{h}{mv} = \frac{h}{\sqrt{2mE}}$$

Where E is kinetic energy

$$E = \frac{3kT}{2} \text{ for gas}$$

$$\lambda = \frac{h}{\sqrt{3mkT}} = \frac{6.6 \times 10^{-34}}{\sqrt{3 \times 9 \times 10^{-31} \times 1.38 \times 10^{-23} \times 300}}$$

$$\lambda = 6.26 \times 10^{-9} \text{ m} = 6.26 \text{ nm}$$

Option (1)

4. A body of mass 'm' dropped from a height 'h' reaches the ground with a speed of $0.8\sqrt{gh}$. The value of workdone by the air-friction is :

- (1) $-0.68 mgh$ (2) mgh
 (3) $1.64 mgh$ (4) $0.64 mgh$

Official Ans. by NTA (1)

Sol. Work done = Change in kinetic energy

$$W_{mg} + W_{\text{air-friction}} = \frac{1}{2}m(.8\sqrt{gh})^2 - \frac{1}{2}m(0)^2$$

$$W_{\text{air-friction}} = \frac{.64}{2}mgh - mgh = -0.68mgh$$

Option (1)

5. The ranges and heights for two projectiles projected with the same initial velocity at angles 42° and 48° with the horizontal are R_1, R_2 and H_1, H_2 respectively. Choose the correct option :

- (1) $R_1 > R_2$ and $H_1 = H_2$ (2) $R_1 = R_2$ and $H_1 < H_2$
 (3) $R_1 < R_2$ and $H_1 < H_2$ (4) $R_1 = R_2$ and $H_1 = H_2$

Official Ans. by NTA (2)

Sol. Range $R = \frac{u^2 \sin 2\theta}{g}$ and same for θ and $90 - \theta$

So same for 42° and 48°

$$\text{Maximum height } H = \frac{u^2 \sin^2 \theta}{2g}$$

H is high for higher θ

So H for 48° is higher than H for 42°

Option (2)

6. A block of mass m slides on the wooden wedge, which in turn slides backward on the horizontal surface. The acceleration of the block with respect to the wedge is : Given $m = 8 \text{ kg}, M = 16 \text{ kg}$ Assume all the surfaces shown in the figure to be frictionless.

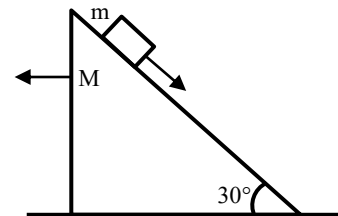

- (1) $\frac{4}{3}g$ (2) $\frac{6}{5}g$ (3) $\frac{3}{5}g$ (4) $\frac{2}{3}g$

Official Ans. by NTA (4)

Sol. Let acceleration of wedge is a_1 and acceleration of block w.r.t. wedge is a_2

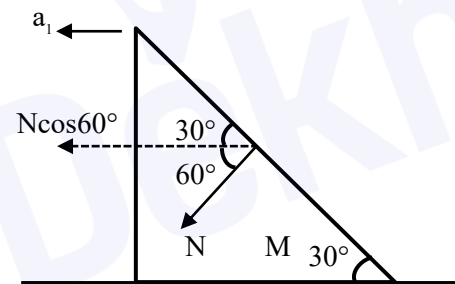

$$N \cos 60^\circ = M a_1 = 16 a_1$$

$$\Rightarrow N = 32 a_1$$

F.B.D. of block w.r.t wedge

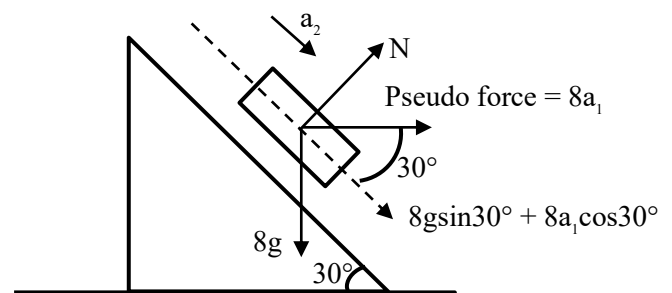

\perp to incline

$$N = 8g \cos 30^\circ - 8a_1 \sin 30^\circ \Rightarrow 32a_1 =$$

$$4\sqrt{3}g - 4a_1$$

$$\Rightarrow a_1 = \frac{\sqrt{3}}{9} g$$

Along incline

$$8g\sin 30^\circ + 8a_1\cos 30^\circ = ma_2 = 8a_2$$

$$a_2 = g \times \frac{1}{2} + \frac{\sqrt{3}}{9} g \cdot \frac{\sqrt{3}}{2} = \frac{2g}{3}$$

Option (4)

7. Due to cold weather a 1 m water pipe of cross-sectional area 1 cm² is filled with ice at -10°C. Resistive heating is used to melt the ice. Current of 0.5 A is passed through 4 kΩ resistance. Assuming that all the heat produced is used for melting, what is the minimum time required ?

(Given latent heat of fusion for water/ice = 3.33 × 10⁵ J kg⁻¹, specific heat of ice = 2 × 10³ J kg⁻¹ and density of ice = 10³ kg / m³)

- (1) 0.353 s (2) 35.3 s
(3) 3.53 s (4) 70.6 s

Official Ans. by NTA (2)

Sol. mass of ice $m = \rho A l = 10^3 \times 10^{-4} \times 1 = 10^{-1}$ kg

Energy required to melt the ice

$$Q = ms\Delta T + mL$$

$$= 10^{-1} (2 \times 10^3 \times 10 + 3.33 \times 10^5) = 3.53 \times 10^4 \text{ J}$$

$$Q = i^2 RT \Rightarrow 3.53 \times 10^4 = \left(\frac{1}{2}\right)^2 (4 \times 10^3) (t)$$

$$\text{Time} = 35.3 \text{ sec}$$

Option (2)

8. A student determined Young's Modulus of elasticity using the formula $Y = \frac{MgL^3}{4bd^3\delta}$. The value of g is taken to be 9.8 m/s², without any significant error, his observation are as following.

Physical Quantity	Least count of the Equipment used for measurement	Observed value
Mass (M)	1 g	2 kg
Length of bar (L)	1 mm	1 m
Breadth of bar (b)	0.1 mm	4 cm
Thickness of bar (d)	0.01 mm	0.4 cm
Depression (δ)	0.01 mm	5 mm

Then the fractional error in the measurement of Y is :

- (1) 0.0083 (2) 0.0155
(3) 0.155 (4) 0.083

Official Ans. by NTA (2)

Sol. $y = \frac{MgL^3}{4bd^3\delta}$

$$\frac{\Delta y}{y} = \frac{\Delta M}{M} + \frac{3\Delta L}{L} + \frac{\Delta b}{b} + \frac{3\Delta d}{d} + \frac{\Delta \delta}{\delta}$$

$$\frac{\Delta y}{y} = \frac{10^{-3}}{2} + \frac{3 \times 10^{-3}}{1} + \frac{10^{-2}}{4} + \frac{3 \times 10^{-2}}{4} + \frac{10^{-2}}{5}$$

$$= 10^{-3} [0.5 + 3 + 2.5 + 7.5 + 2] = 0.0155$$

Option (2)

9. Two resistors $R_1 = (4 \pm 0.8) \Omega$ and $R_2 = (4 \pm 0.4) \Omega$ are connected in parallel. The equivalent resistance of their parallel combination will be :

- (1) $(4 \pm 0.4) \Omega$
(2) $(2 \pm 0.4) \Omega$
(3) $(2 \pm 0.3) \Omega$
(4) $(4 \pm 0.3) \Omega$

Official Ans. by NTA (3)

Sol. $\frac{1}{R_{eq}} = \frac{1}{R_1} + \frac{1}{R_2}$

$$\frac{1}{R_{eq}} = \frac{1}{4} + \frac{1}{4} \Rightarrow R_{eq} = 2\Omega$$

$$\text{Also } \frac{\Delta R_{eq}}{R_{eq}^2} = \frac{\Delta R_1}{R_1^2} + \frac{\Delta R_2}{R_2^2}$$

$$\frac{\Delta R_{eq}}{4} = \frac{.8}{16} + \frac{.4}{16} = \frac{1.2}{16}$$

$$\underline{\Delta R_{eq}} = 0.3\Omega$$

$$R_{eq} = (2 \pm 0.3)\Omega$$

Option (3)

10. The half life period of radioactive element x is same as the mean life time of another radioactive element y . Initially they have the same number of atoms.

Then :

- (1) x-will decay faster than y.
- (2) y- will decay faster than x.
- (3) x and y have same decay rate initially and later on different decay rate.
- (4) x and y decay at the same rate always.

Official Ans. by NTA (2)

Sol. $(t_{1/2})_x = (\tau)_y$

$$\Rightarrow \frac{\ln 2}{\lambda_x} = \frac{1}{\lambda_y} \Rightarrow \lambda_x = 0.693 \lambda_y$$

Also initially $N_x = N_y = N_0$

Activity $A = \lambda N$

As $\lambda_x < \lambda_y \Rightarrow A_x < A_y$

\Rightarrow y will decay faster than x

Option (2)

11. Following plots show Magnetization (M) vs Magnetising field (H) and Magnetic susceptibility (χ) vs temperature (T) graph :

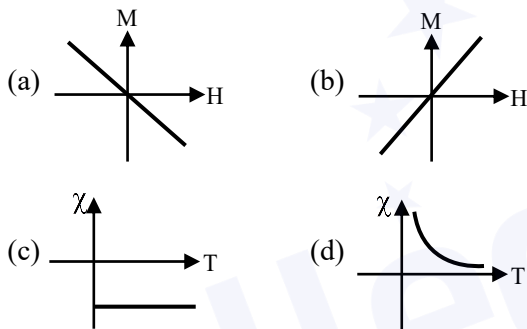

Which of the following combination will be represented by a diamagnetic material?

- (1) (a), (c)
- (2) (a), (d)
- (3) (b), (d)
- (4) (b), (c)

Official Ans. by NTA (1)

Sol. Conceptual question

Option (1)

12. A glass tumbler having inner depth of 17.5 cm is kept on a table. A student starts pouring water ($\mu = 4/3$) into it while looking at the surface of water from the above. When he feels that the tumbler is half filled, he stops pouring water. Up to what height, the tumbler is actually filled ?

- (1) 11.7 cm
- (2) 10 cm
- (3) 7.5 cm
- (4) 8.75 cm

Official Ans. by NTA (2)

Sol.

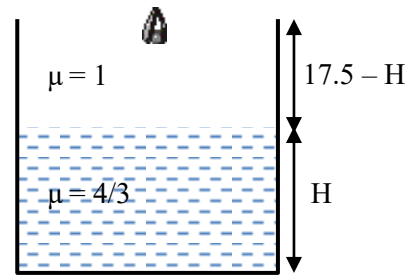

Height of water observed by observer

$$= \frac{H}{\mu_w} = \frac{H}{(4/3)} = \frac{3H}{4}$$

Height of air observed by observer = $17.5 - H$

According to question, both height observed by observer is same.

$$\frac{3H}{4} = 17.5 - H$$

$$\Rightarrow H = 10 \text{ cm}$$

Option (2)

13. In the given figure, each diode has a forward bias resistance of 30Ω and infinite resistance in reverse bias. The current I_1 will be :

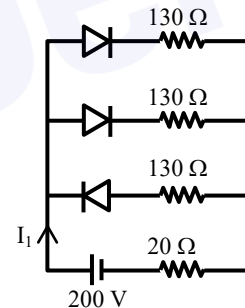

- (1) 3.75 A
- (2) 2.35 A
- (3) 2 A
- (4) 2.73 A

Official Ans. by NTA (3)

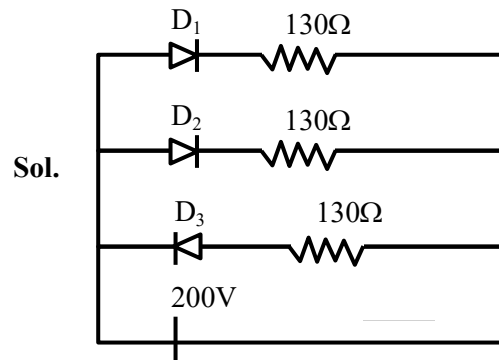

As per diagram,

Diode D_1 & D_2 are in forward bias i.e. $R = 30\Omega$ whereas diode D_3 is in reverse bias i.e. $R = \infty$

\Rightarrow Equivalent circuit will be

Applying KVL starting from point A

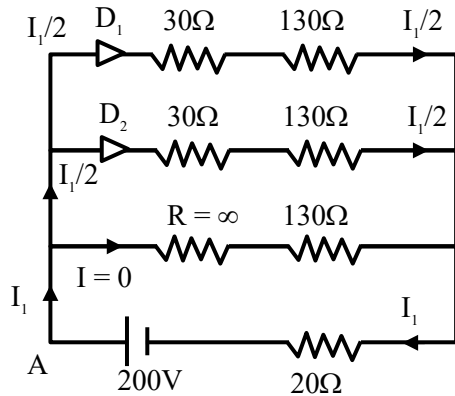

$$-\left(\frac{I_1}{2}\right) \times 30 - \left(\frac{I_1}{2}\right) \times 130 - I_1 \times 20 + 200 = 0$$

$$\Rightarrow -100 I_1 + 200 = 0$$

$$I_1 = 2$$

Option (3)

14. For the given circuit the current i through the battery when the key in closed and the steady state has been reached is _____.

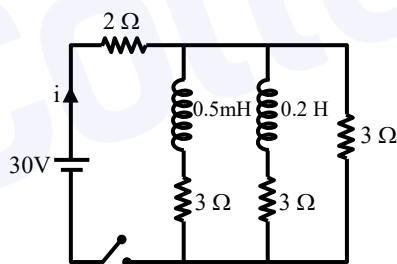

- (1) 6 A (2) 25 A
(3) 10 A (4) 0 A

Official Ans. by NTA (3)

Sol. In steady state, inductor behaves as a conducting wire.

So, equivalent circuit becomes

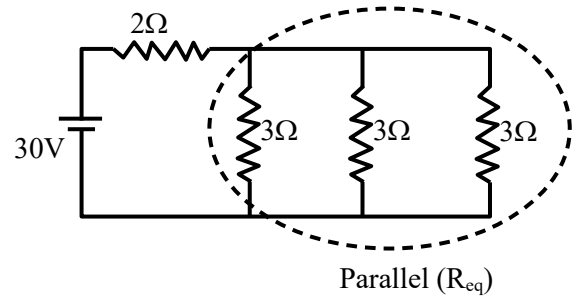

$$\frac{1}{R_{eq}} = \frac{1}{3} + \frac{1}{3} + \frac{1}{3} = 1$$

$$\Rightarrow R_{eq} = 1\Omega$$

\Rightarrow Circuit becomes

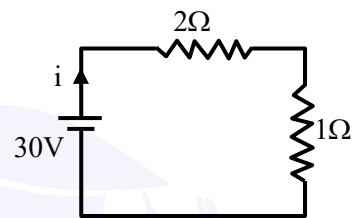

$$\Rightarrow i = \frac{30}{3} = 10A$$

15. An object of mass 'm' is being moved with a constant velocity under the action of an applied force of 2N along a frictionless surface with following surface profile.

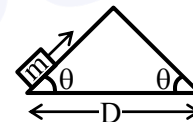

The correct applied force vs distance graph will be:

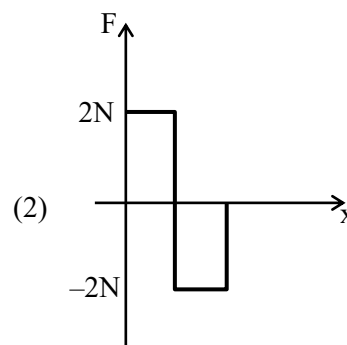
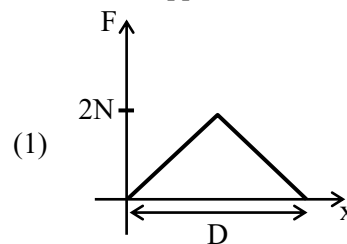

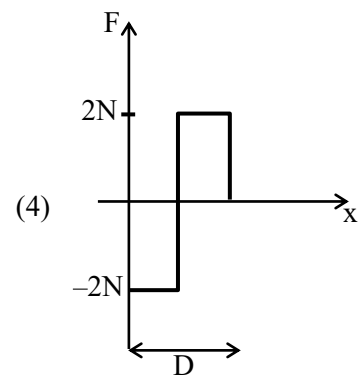
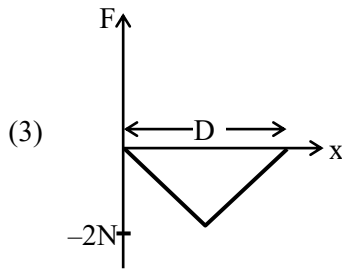

Official Ans. by NTA (2)

Sol. During upward motion

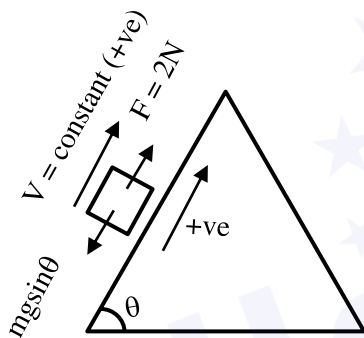

$F = 2N = (+ve)$ constant
During downward motion

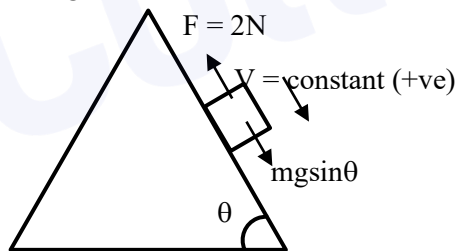

$\Rightarrow F = 2N = (-ve)$ constant
 \Rightarrow Best possible answer is option (2)

16. A mass of 5 kg is connected to a spring. The potential energy curve of the simple harmonic motion executed by the system is shown in the figure. A simple pendulum of length 4 m has the same period of oscillation as the spring system. What is the value of acceleration due to gravity on the planet where these experiments are performed?

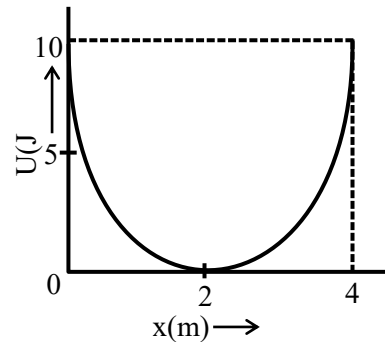

- (1) 10 m/s^2 (2) 5 m/s^2
(3) 4 m/s^2 (4) 9.8 m/s^2

Official Ans. by NTA (3)

Sol. From potential energy curve

$$U_{\max} = \frac{1}{2} kA^2 \Rightarrow 10 = \frac{1}{2} k(2)^2$$

$$\Rightarrow k = 5$$

$$\text{Now } T_{\text{spring}} = T_{\text{pendulum}}$$

$$2\pi\sqrt{\frac{5}{5}} = 2\pi\sqrt{\frac{4}{g}}$$

$$\Rightarrow 1 = \sqrt{\frac{4}{g}} \Rightarrow g = 4 \text{ on planet}$$

Option (3)

17. A capacitor is connected to a 20 V battery through a resistance of 10Ω . It is found that the potential difference across the capacitor rises to 2 V in $1 \mu\text{s}$. The capacitance of the capacitor is μF .

$$\text{Given : } \ln\left(\frac{10}{9}\right) = 0.105$$

- (1) 9.52 (2) 0.95
(3) 0.105 (4) 1.85

Official Ans. by NTA (2)

Sol. $V = V_0(1 - e^{-t/RC})$

$$2 = 20(1 - e^{-t/RC})$$

$$\frac{1}{10} = 1 - e^{-t/RC}$$

$$e^{-t/RC} = \frac{9}{10}$$

$$e^{t/RC} = \frac{10}{9}$$

$$\frac{t}{RC} = \ln\left(\frac{10}{9}\right) \Rightarrow C = \frac{t}{R \ln\left(\frac{10}{9}\right)}$$

$$C = \frac{10^{-6}}{10 \times 10^5} = .95 \mu\text{F}$$

Option (2)

18. Four particles each of mass M , move along a circle of radius R under the action of their mutual gravitational attraction as shown in figure. The speed of each particle is :

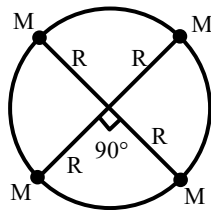

(1) $\frac{1}{2} \sqrt{\frac{GM}{R(2\sqrt{2}+1)}}$ (2) $\frac{1}{2} \sqrt{\frac{GM}{R}(2\sqrt{2}+1)}$

(3) $\frac{1}{2} \sqrt{\frac{GM}{R}(2\sqrt{2}-1)}$ (4) $\sqrt{\frac{GM}{R}}$

Official Ans. by NTA (2)

Sol.

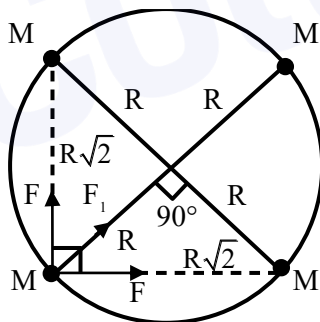

$$F_{\text{net}} = \frac{MV^2}{R}$$

$$\sqrt{2}F + F_1 = \frac{MV^2}{R}$$

$$\sqrt{2} \frac{GMM}{(\sqrt{2}R)^2} + \frac{GMM}{(2R)^2} = \frac{MV^2}{R}$$

$$\frac{GM}{R} \left(\frac{1}{\sqrt{2}} + \frac{1}{4} \right) = V^2$$

$$\frac{GM}{R} \left(\frac{4+\sqrt{2}}{4\sqrt{2}} \right) = V^2$$

$$V = \sqrt{\frac{GM(4+\sqrt{2})}{R4\sqrt{2}}}$$

$$V = \frac{1}{2} \sqrt{\frac{GM(2\sqrt{2}+1)}{R}}$$

Option (2)

19. Electric field of plane electromagnetic wave propagating through a non-magnetic medium is given by $E = 20\cos(2 \times 10^{10} t - 200x)$ V/m. The dielectric constant of the medium is equal to :

(Take $\mu_r = 1$)

(1) 9 (2) 2

(3) $\frac{1}{3}$ (4) 3

Official Ans. by NTA (1)

Sol. Speed of wave = $\frac{2 \times 10^{10}}{200} = 10^8 \text{ m/s}$

Refractive index = $\frac{3 \times 10^8}{10^8} = 3$

Now refractive index = $\sqrt{\epsilon_r \mu_r}$

$3 = \sqrt{\epsilon_r (1)}$

$\Rightarrow \epsilon_r = 9$

Option (1)

20. There are two infinitely long straight current carrying conductors and they are held at right angles to each other so that their common ends meet at the origin as shown in the figure given below. The ratio of current in both conductor is 1 : 1. The magnetic field at point P is ____.

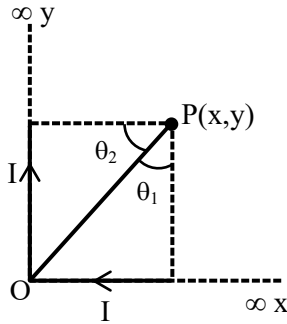

$$(1) \frac{\mu_0 I}{4\pi xy} \left[\sqrt{x^2 + y^2} + (x + y) \right]$$

$$(2) \frac{\mu_0 I}{4\pi xy} \left[\sqrt{x^2 + y^2} - (x + y) \right]$$

$$(3) \frac{\mu_0 Ixy}{4\pi} \left[\sqrt{x^2 + y^2} - (x + y) \right]$$

$$(4) \frac{\mu_0 Ixy}{4\pi} \left[\sqrt{x^2 + y^2} + (x + y) \right]$$

Official Ans. by NTA (1)

Sol.

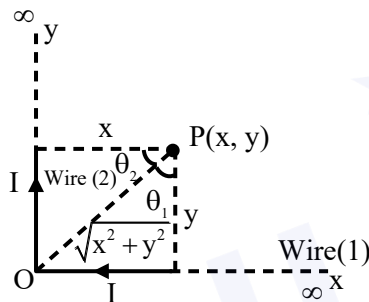

$$B_{\text{due to wire (1)}} = \frac{\mu_0 I}{4\pi y} \left[\sin 90^\circ + \sin \theta_1 \right]$$

$$= \frac{\mu_0 I}{4\pi y} \left(1 + \frac{x}{\sqrt{x^2 + y^2}} \right) \dots\dots(1)$$

$$B_{\text{due to wire (2)}} = \frac{\mu_0 I}{4\pi x} (\sin 90^\circ + \sin \theta_2)$$

$$= \frac{\mu_0 I}{4\pi x} \left(1 + \frac{y}{\sqrt{x^2 + y^2}} \right) \dots\dots(2)$$

Total magnetic field

$$B = B_1 + B_2$$

$$B = \frac{\mu_0 I}{4\pi} \left[\frac{1}{y} + \frac{x}{y\sqrt{x^2 + y^2}} + \frac{1}{x} + \frac{y}{x\sqrt{x^2 + y^2}} \right]$$

$$B = \frac{\mu_0 I}{4\pi} \left[\frac{x+y}{xy} + \frac{x^2+y^2}{xy\sqrt{x^2+y^2}} \right]$$

$$B = \frac{\mu_0 I}{4\pi} \left[\frac{x+y}{xy} + \frac{\sqrt{x^2+y^2}}{xy} \right]$$

$$B = \frac{\mu_0 I}{4\pi xy} \left[\sqrt{x^2+y^2} + (x+y) \right]$$

Option (1)

SECTION-B

- The temperature of 3.00 mol of an ideal diatomic gas is increased by 40.0 °C without changing the pressure of the gas. The molecules in the gas rotate but do not oscillate. If the ratio of change in internal energy of the gas to the amount of workdone by the gas is $\frac{x}{10}$. Then the value of x

(round off to the nearest integer) is _____.

(Given R = 8.31 J mol⁻¹ K⁻¹)

Official Ans. by NTA (25)

- Sol. Pressure is not changing ⇒ isobaric process

$$\Rightarrow \Delta U = nC_v \Delta T = \frac{5nR\Delta T}{2}$$

$$\text{and } W = nR\Delta T$$

$$\frac{\Delta U}{W} = \frac{5}{2} = \frac{x}{10} \Rightarrow x = 25.00$$

- The width of one of the two slits in a Young's double slit experiment is three times the other slit. If the amplitude of the light coming from a slit is proportional to the slit-width, the ratio of minimum to maximum intensity in the interference pattern is x : 4 where x is _____.

Official Ans. by NTA (1)

- Sol. Given amplitude ∝ slit width

Also intensity ∝ (Amplitude)² ∝ (Slit width)²

$$\frac{I_1}{I_2} = \left(\frac{3}{1} \right)^2 = 9 \Rightarrow I_1 = 9I_2$$

$$\frac{I_{\min}}{I_{\max}} = \left(\frac{\sqrt{I_1} - \sqrt{I_2}}{\sqrt{I_1} + \sqrt{I_2}} \right)^2 = \left(\frac{3-1}{3+1} \right)^2 = \frac{1}{4} = \frac{x}{4}$$

$$\Rightarrow x = 1.00$$

3. Two satellites revolve around a planet in coplanar circular orbits in anticlockwise direction. Their period of revolutions are 1 hour and 8 hours respectively. The radius of the orbit of nearer satellite is 2×10^3 km. The angular speed of the farther satellite as observed from the nearer satellite at the instant when both the satellites are closest is $\frac{\pi}{x}$ rad h^{-1} where x is

Official Ans. by NTA (3)

Sol.

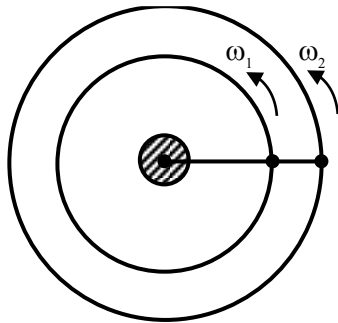

$$T_1 = 1 \text{ hour}$$

$$\Rightarrow \omega_1 = 2\pi \text{ rad/hour}$$

$$T_2 = 8 \text{ hours}$$

$$\Rightarrow \omega_2 = \frac{\pi}{4} \text{ rad / hour}$$

$$R_1 = 2 \times 10^3 \text{ km}$$

$$\text{As } T^2 \propto R^3$$

$$\Rightarrow \left(\frac{R_2}{R_1}\right)^3 = \left(\frac{T_2}{T_1}\right)^2$$

$$\Rightarrow \frac{R_2}{R_1} = \left(\frac{8}{1}\right)^{2/3} = 4 \Rightarrow R_2 = 8 \times 10^3 \text{ km}$$

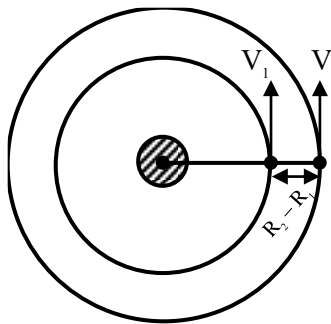

$$V_1 = \omega_1 R_1 = 4\pi \times 10^3 \text{ km / h}$$

$$V_2 = \omega_2 R_2 = 2\pi \times 10^3 \text{ km / h}$$

$$\text{Relative } \omega = \frac{V_1 - V_2}{R_2 - R_1} = \frac{2\pi \times 10^3}{6 \times 10^3}$$

$$= \frac{\pi}{3} \text{ rad / hour}$$

$$x = 3$$

4. When a body slides down from rest along a smooth inclined plane making an angle of 30° with the horizontal, it takes time T. When the same body slides down from the rest along a rough inclined plane making the same angle and through the same distance, it takes time αT , where α is a constant greater than 1. The co-efficient of friction between the body and the rough plane is $\frac{1}{\sqrt{x}}$

$$\left(\frac{\alpha^2 - 1}{\alpha^2}\right) \text{ where } x = \dots\dots\dots$$

Official Ans. by NTA (3)

Sol.

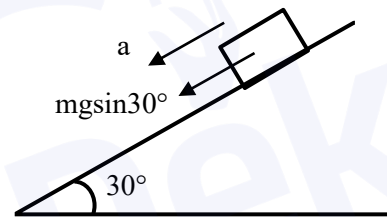

On smooth incline

$$a = g \sin 30^\circ$$

$$\text{by } S = ut + \frac{1}{2}at^2$$

$$S = \frac{1}{2} \frac{g}{2} T^2 = \frac{g}{4} T^2 \dots\dots\dots(i)$$

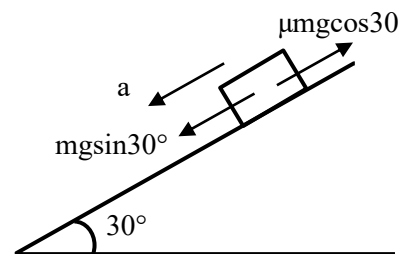

On rough incline

$$a = g \sin 30^\circ - \mu g \cos 30^\circ$$

$$\text{by } S = ut + \frac{1}{2}at^2$$

$$S = \frac{1}{4}g(1 - \sqrt{3}\mu)(\alpha T)^2 \dots(ii)$$

By (i) and (ii)

$$\frac{1}{4}gT^2 = \frac{1}{4}g(1 - \sqrt{3}\mu)\alpha^2 T^2$$

$$\Rightarrow 1 - \sqrt{3}\mu = \frac{1}{\alpha^2} \Rightarrow g = \left(\frac{\alpha^2 - 1}{\alpha^2}\right) \cdot \frac{1}{\sqrt{3}}$$

$$\Rightarrow x = 3.00$$

5. The average translational kinetic energy of N_2 gas molecules at $^{\circ}C$ becomes equal to the K.E. of an electron accelerated from rest through a potential difference of 0.1 volt.

(Given $k_B = 1.38 \times 10^{-23}$ J/K)

(Fill the nearest integer).

Official Ans. by NTA (500)

Sol. Given

Translation K.E. of $N_2 =$ K.E. of electron

$$\frac{3}{2}kT = eV$$

$$\frac{3}{2} \times 1.38 \times 10^{-23} T = 1.6 \times 10^{-19} \times 0.1$$

$$\Rightarrow T = 773k$$

$$T = 773 - 273 = 500^{\circ}C$$

6. A uniform heating wire of resistance 36Ω is connected across a potential difference of 240 V. The wire is then cut into half and potential difference of 240 V is applied across each half separately. The ratio of power dissipation in first case to the total power dissipation in the second case would be $1 : x$, where x is.....

Official Ans. by NTA (4)

Sol. First case $P_1 = \frac{V^2}{R} = \frac{(240)^2}{36}$

Second case Resistance of each half = 18Ω

$$P_2 = \frac{(240)^2}{18} + \frac{(240)^2}{18} = \frac{(240)^2}{9}$$

$$\frac{P_1}{P_2} = \frac{1}{4}$$

$$x = 4.00$$

7. A steel rod with $y = 2.0 \times 10^{11}$ Nm^{-2} and $\alpha = 10^{-5}$ $^{\circ}C^{-1}$ of length 4 m and area of cross-section 10 cm^2 is heated from $0^{\circ}C$ to $400^{\circ}C$ without being allowed to extend. The tension produced in the rod is $x \times 10^5$ N where the value of x is

Official Ans. by NTA (8)

Sol. Thermal force $F = Ay\alpha\Delta T$

$$F = (10 \times 10^{-4}) (2 \times 10^{11}) (10^{-5})(400)$$

$$F = 8 \times 10^5 \text{ N}$$

$$\Rightarrow x = 8$$

8. A 2 kg steel rod of length 0.6 m is clamped on a table vertically at its lower end and is free to rotate in vertical plane. The upper end is pushed so that the rod falls under gravity, Ignoring the friction due to clamping at its lower end, the speed of the free end of rod when it passes through its lowest position is ms^{-1} . (Take $g = 10 \text{ ms}^{-2}$)

Official Ans. by NTA (6)

Sol.

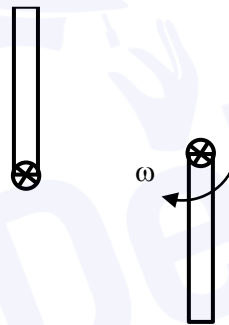

by energy conservation $mg\ell = \frac{1}{2}I\omega^2 = \frac{1}{2} \frac{m\ell^2\omega^2}{3}$

$$\Rightarrow \omega = \sqrt{\frac{6g}{\ell}}$$

Speed $v = \omega r = \omega \ell = \sqrt{6g\ell}$

$$v = \sqrt{6 \times 10 \times 0.6} = 6 \text{ m/s}$$

9. A carrier wave with amplitude of 250 V is amplitude modulated by a sinusoidal base band signal of amplitude 150 V. The ratio of minimum amplitude to maximum amplitude for the amplitude modulated wave is $50 : x$, then value of x is

Official Ans. by NTA (200)

Sol. $A_{\max} = A_c + A_m = 250 + 150 = 400$

$$A_{\min} = A_c - A_m = 250 - 150 = 100$$

$$\frac{A_{\min}}{A_{\max}} = \frac{100}{400} = \frac{1}{4} = \frac{50}{200}$$

$$x = 200$$

10. An engine is attached to a wagon through a shock absorber of length 1.5 m. The system with a total mass of 40,000 kg is moving with a speed of 72 kmh^{-1} when the brakes are applied to bring it to rest. In the process of the system being brought to rest, the spring of the shock absorber gets compressed by 1.0 m. If 90% of energy of the wagon is lost due to friction, the spring constant is $\times 10^5 \text{ N/m}$.

Official Ans. by NTA (16)

Sol. Work = $\Delta \text{K.E.}$

$$W_{\text{friction}} + W_{\text{spring}} = 0 - \frac{1}{2}mv^2$$

$$-\frac{90}{100} \left(\frac{1}{2}mv^2 \right) + W_{\text{Spring}} = -\frac{1}{2}mv^2$$

$$W_{\text{spring}} = -\frac{10}{100} \times \frac{1}{2}mv^2$$

$$-\frac{1}{2}kx^2 = -\frac{1}{20}mv^2$$

$$\Rightarrow k = \frac{40000 \times (20)^2}{10 \times (1)^2} = 16 \times 10^5$$