

FINAL JEE-MAIN EXAMINATION – SEPTEMBER, 2020

(Held On Thursday 03rd SEPTEMBER, 2020) TIME : 9 AM to 12 PM

PHYSICS

TEST PAPER WITH ANSWER & SOLUTION

1. Using screw gauge of pitch 0.1 cm and 50 divisions on its circular scale, the thickness of an object is measured. It should correctly be recorded as :

- (1) 2.123 cm (2) 2.125 cm
 (3) 2.121 cm (4) 2.124 cm

Official Ans. by NTA (4)

Sol. $LC = \frac{\text{pitch}}{\text{CSD}} = \frac{0.1 \text{ cm}}{50} = 0.002 \text{ cm}$

So any measurement will be integral Multiple of LC.

So ans. will be 2.124 cm

2. Model a torch battery of length l to be made up of a thin cylindrical bar of radius 'a' and a concentric thin cylindrical shell of radius 'b' filled in between with an electrolyte of resistivity ρ (see figure). If the battery is connected to a resistance of value R, the maximum Joule heating in R will take place for:-

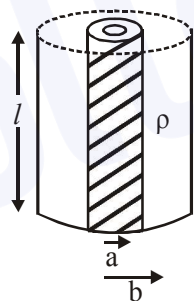

(1) $R = \frac{2\rho}{\pi l} \ln\left(\frac{b}{a}\right)$ (2) $R = \frac{\rho}{\pi l} \ln\left(\frac{b}{a}\right)$

(3) $R = \frac{\rho}{2\pi l} \ln\left(\frac{b}{a}\right)$ (4) $R = \frac{\rho}{2\pi l} \ln\left(\frac{b}{a}\right)$

Sol. Maximum power in external resistance is generated when it is equal to internal resistance of battery.

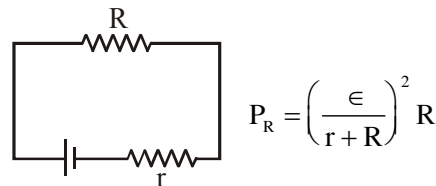

P_R is max. when $r = R$

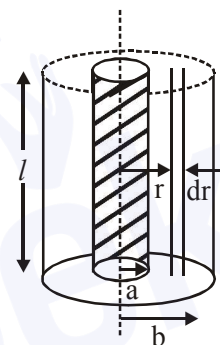

$$\int dr = \int_a^b \frac{\rho dr}{2\pi r l} \Rightarrow r = \frac{\rho}{2\pi l} \ln \frac{b}{a}$$

3. When the wavelength of radiation falling on a metal is changed from 500 nm to 200 nm, the maximum kinetic energy of the photoelectrons becomes three times larger. The work function of the metal is close to :

- (1) 0.61 eV (2) 0.52 eV
 (3) 0.81 eV (4) 1.02 eV

Official Ans. by NTA (1)

Sol. $\frac{3}{1} = \frac{\frac{hc}{200 \text{ nm}} - \phi}{\frac{hc}{500 \text{ nm}} - \phi}$, $hc = 1240 \text{ eV-nm}$

4. Moment of inertia of a cylinder of mass M , length L and radius R about an axis passing through its centre and perpendicular to the axis

of the cylinder is $I = M \left(\frac{R^2}{4} + \frac{L^2}{12} \right)$. If such a

cylinder is to be made for a given mass of material, the ratio L/R for it to have minimum possible I is :-

- (1) $\sqrt{\frac{2}{3}}$ (2) $\frac{3}{2}$ (3) $\sqrt{\frac{3}{2}}$ (4) $\frac{2}{3}$

Official Ans. by NTA (3)

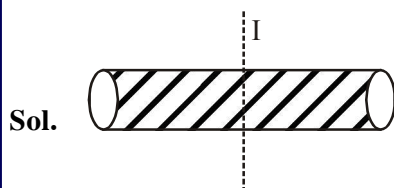

$$I = M \left(\frac{R^2}{4} + \frac{L^2}{12} \right) \quad \dots(1)$$

as mass is constant $\Rightarrow m = \rho V = \text{constant}$

$V = \text{constant}$

$\pi R^2 L = \text{constant} \Rightarrow R^2 L = \text{constant}$

$$2RL + R^2 \frac{dL}{dR} = 0 \quad \dots(2)$$

From equation (1)

$$\frac{dI}{dR} = M \left(\frac{2R}{4} + \frac{2L}{12} \times \frac{dL}{dR} \right) = 0$$

$$\frac{R}{2} + \frac{L}{6} \frac{dL}{dR} = 0$$

Substituting value of $\frac{dL}{dR}$ from equation (2)

$$\frac{R}{2} + \frac{L}{6} \left(\frac{-2L}{R} \right) = 0$$

$$\frac{R}{2} = \frac{L^2}{3} \Rightarrow \frac{L}{R} = \sqrt{\frac{3}{2}}$$

5. The magnetic field of a plane electromagnetic wave is

$$\vec{B} = 3 \times 10^{-8} \sin[200\pi(y + ct)] \hat{i} \text{ T}$$

Where $c = 3 \times 10^8 \text{ ms}^{-1}$ is the speed of light.

The corresponding electric field is :

(1) $\vec{E} = -10^{-6} \sin[200\pi(y + ct)] \hat{k} \text{ V/m}$

(2) $\vec{E} = -9 \sin[200\pi(y + ct)] \hat{k} \text{ V/m}$

(3) $\vec{E} = 9 \sin[200\pi(y + ct)] \hat{k} \text{ V/m}$

(4) $\vec{E} = 3 \times 10^{-8} \sin[200\pi(y + ct)] \hat{k} \text{ V/m}$

Official Ans. by NTA (2)

Sol. $\vec{B} = 3 \times 10^{-8} \sin[200\pi(y + ct)] \hat{i} \text{ T}$

$$E_0 = cB_0 \Rightarrow E_0 = 3 \times 10^8 \times 3 \times 10^{-8}$$

$$= 9 \text{ V/m}$$

and direction of wave propagation is given as

$$(\vec{E} \times \vec{B}) \parallel \vec{C}$$

$$\hat{B} = \hat{i} \quad \& \quad \hat{C} = -\hat{j}$$

$$\text{so } \hat{E} = -\hat{k}$$

$$\therefore \vec{E} = E_0 \sin[200\pi(y + ct)](-\hat{k}) \text{ V/m}$$

6. A charged particle carrying charge $1 \mu\text{C}$ is

moving with velocity $(2\hat{i} + 3\hat{j} + 4\hat{k}) \text{ ms}^{-1}$. If an

external magnetic field of $(5\hat{i} + 3\hat{j} - 6\hat{k}) \times 10^{-3} \text{ T}$

exists in the region where the particle is moving

then the force on the particle is $\vec{F} \times 10^{-9} \text{ N}$. The

vector \vec{F} is :

(1) $-0.30\hat{i} + 0.32\hat{j} - 0.09\hat{k}$

(2) $-300\hat{i} + 320\hat{j} - 90\hat{k}$

(3) $-30\hat{i} + 32\hat{j} - 9\hat{k}$

(4) $-3.0\hat{i} + 3.2\hat{j} - 0.9\hat{k}$

Official Ans. by NTA (3)

Sol. $\vec{F} = q(\vec{v} \times \vec{B})$ (Force on charge particle moving

in magnetic field)

$$= \begin{pmatrix} \hat{i} & \hat{j} & \hat{k} \\ 2 & 3 & 4 \\ 5 & 3 & -6 \end{pmatrix} \times 10^{-3}$$

$$= [\hat{i}[-18-12] - \hat{j}[-12-20] + \hat{k}[6-15]] \times 10^{-3}$$

$$= [\hat{i}[-30] + \hat{j}[32] + \hat{k}[-9]] \times 10^{-3}$$

$$\text{Force} = 10^{-6}[-30\hat{i} + 32\hat{j} - 9\hat{k}] \times 10^{-3}$$

$$= 10^{-9}[-30\hat{i} + 32\hat{j} - 9\hat{k}]$$

7. A 750 Hz, 20 V (rms) source is connected to a resistance of 100Ω , an inductance of 0.1803 H and a capacitance of $10 \mu\text{F}$ all in series. The time in which the resistance (heat capacity $2\text{J}/^\circ\text{C}$) will get heated by 10°C . (assume no loss of heat to the surroundings) is close to :

- (1) 418 s (2) 245 s (3) 348 s (4) 365 s

Official Ans. by NTA (3)

Sol. $f = 750 \text{ Hz}, \quad V_{\text{rms}} = 20\text{V},$
 $R = 100 \Omega, \quad L = 0.1803 \text{ H},$
 $C = 10 \mu\text{F}, S = 2 \text{ J}/^\circ\text{C}$

$$Z = \sqrt{R^2 + (X_L - X_C)^2} = \sqrt{R^2 + (\omega L - 1/\omega C)^2}$$

$$= \sqrt{R^2 + \left(2\pi fL - \frac{1}{2\pi fC}\right)^2}$$

Putting values

$$|Z| = 834 \Omega$$

$$\text{In AC power } P = V_{\text{rms}} i_{\text{rms}} \cos\phi$$

$$\cos\phi = \frac{R}{|Z|} \quad i_{\text{rms}} = \frac{V_{\text{rms}}}{|Z|}$$

$$= \frac{V_{\text{rms}}^2 R}{(|Z|)^2}$$

$$= \left(\frac{20}{834}\right)^2 \times 100 = 0.0575 \text{ J/s}$$

$$H = Pt = S\Delta\theta$$

$$2(10)$$

8. In a radioactive material, fraction of active material remaining after time t is $9/16$. The fraction that was remaining after $t/2$ is :

- (1) $\frac{3}{4}$ (2) $\frac{7}{8}$ (3) $\frac{4}{5}$ (4) $\frac{3}{5}$

Official Ans. by NTA (1)

Sol. First order decay

$$N(t) = N_0 e^{-\lambda t}$$

$$\text{Given } N(t) / N_0 = 9/16 = e^{-\lambda t}$$

$$\text{Now, } N(t/2) = N_0 e^{-\lambda t/2}$$

$$\frac{N(t/2)}{N_0} = \sqrt{e^{-\lambda t}} = \sqrt{9/16}$$

$$N(t/2) = 3/4 N_0$$

9. A balloon filled with helium (32°C and 1.7 atm.) bursts. Immediately afterwards the expansion of helium can be considered as :

- (1) Irreversible isothermal
 (2) Irreversible adiabatic
 (3) Reversible adiabatic
 (4) Reversible isothermal

Official Ans. by NTA (2)

Sol. Bursting of helium balloon is irreversible & adiabatic.

10. Pressure inside two soap bubbles are 1.01 and 1.02 atmosphere, respectively. The ratio of their volumes is :

- (1) $8 : 1$ (2) $0.8 : 1$
 (3) $2 : 1$ (4) $4 : 1$

Official Ans. by NTA (1)

$$\text{Sol. } \Delta P_1 = 0.01 = 4T/R_1 \quad \dots(1)$$

$$\Delta P_2 = 0.02 = 4T/R_2 \quad \dots(2)$$

$$\text{Equation (1)} \div (2)$$

$$\frac{1}{2} = \frac{R_2}{R_1}$$

$$R_1 = 2R_2$$

$$\underline{V_1} \quad \underline{R_1^3} \quad \underline{8R_2^3}$$

11. A satellite is moving in a low nearly circular orbit around the earth. Its radius is roughly equal to that of the earth's radius R_e . By firing rockets attached to it, its speed is instantaneously increased in the direction of its motion so that it becomes $\sqrt{\frac{3}{2}}$ times larger. Due to this the farthest distance from the centre of the earth that the satellite reaches is R , value of R is :

- (1) $4R_e$ (2) $3R_e$ (3) $2R_e$ (4) $2.5R_e$

Official Ans. by NTA (2)

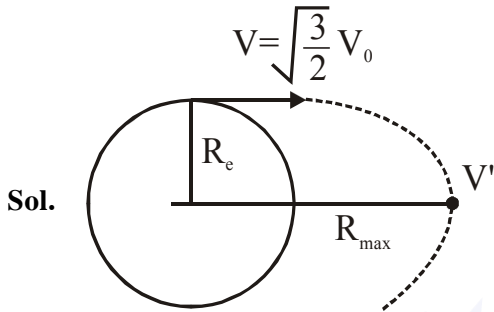

$$V_0 = \sqrt{\frac{GM}{R_e}}$$

$$\frac{-GMm}{R_e} + \frac{1}{2}mv^2 = \frac{-GMm}{R_{\max}} + \frac{1}{2}mv'^2 \quad \dots(i)$$

$$VR_e = V'R_{\max} \quad \dots(ii)$$

Solving (i) & (ii)

$$\boxed{R_{\max} = 3R_e}$$

12. In the circuit shown in the figure, the total charge is $750 \mu\text{C}$ and the voltage across capacitor C_2 is 20 V . Then the charge on capacitor C_2 is :

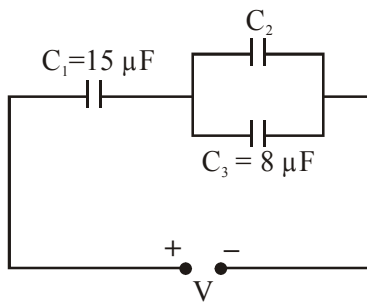

- (1) $590 \mu\text{C}$ (2) $450 \mu\text{C}$
 (3) $650 \mu\text{C}$ (4) $160 \mu\text{C}$

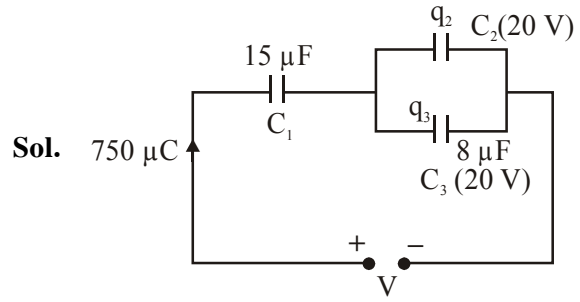

$$q_3 = 20 \times 8 = 160 \mu\text{C}$$

$$\therefore q_2 = 750 - 160 = 590 \mu\text{C}$$

13. An elliptical loop having resistance R , of semi major axis a , and semi minor axis b is placed in a magnetic field as shown in the figure. If the loop is rotated about the x -axis with angular frequency ω , the average power loss in the loop due to Joule heating is :

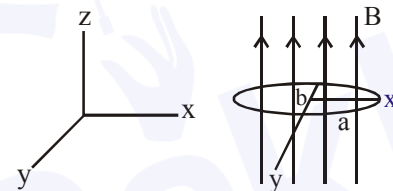

(1) $\frac{\pi^2 a^2 b^2 B^2 \omega^2}{2R}$ (2) Zero

(3) $\frac{\pi^2 a^2 b^2 B^2 \omega^2}{R}$ (4) $\frac{\pi ab B \omega}{R}$

Official Ans. by NTA (1)

Sol. $\epsilon = NAB\omega \cos \omega t$ $N = 1$

$$P_{\text{avg}} = \left\langle \frac{\epsilon^2}{R} \right\rangle = \left\langle \frac{(AB\omega \cos \omega t)^2}{R} \right\rangle$$

$$= \frac{A^2 B^2 \omega^2}{R} \frac{1}{2} = \frac{\pi^2 a^2 b^2 B^2 \omega^2}{2R}$$

14. When a diode is forward biased, it has a voltage drop of 0.5 V . The safe limit of current through the diode is 10 mA . If a battery of emf 1.5 V is used in the circuit, the value of minimum resistance to be connected in series with the diode so that the current does not exceed the safe limit is :

- (1) 100Ω (2) 50Ω
 (3) 300Ω (4) 200Ω

Sol.

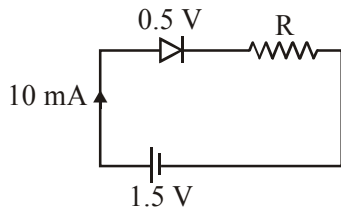

$$1.5 - 0.5 - R \times 10 \times 10^{-3} = 0$$

$$\therefore R = 100 \Omega$$

15. A uniform thin rope of length 12 m and mass 6 kg hangs vertically from a rigid support and a block of mass 2 kg is attached to its free end. A transverse short wavetrain of wavelength 6 cm is produced at the lower end of the rope. What is the wavelength of the wavetrain (in cm) when it reaches the top of the rope ?

- (1) 9 (2) 12 (3) 6 (4) 3

Official Ans. by NTA (2)

Sol.

$$V \propto \lambda \quad T_2 = 8g$$

$$T_1 = 2g$$

$$\frac{V_1}{V_2} = \frac{\lambda_1}{\lambda_2}$$

$$\lambda_2 = \frac{V_2}{V_1} \lambda_1 = \sqrt{\frac{T_2}{T_1}} \times \lambda_1$$

$$= \sqrt{\frac{8g}{2g}} \lambda_1 = 2 \times 6 = 12 \text{ cm}$$

16. A block of mass $m = 1 \text{ kg}$ slides with velocity $v = 6 \text{ m/s}$ on a frictionless horizontal surface and collides with a uniform vertical rod and sticks to it as shown. The rod is pivoted about O and swings as a result of the collision making angle θ before momentarily coming to rest. If the rod has mass $M = 2 \text{ kg}$, and length $l = 1 \text{ m}$, the value of θ is approximately :
(Take $g = 10 \text{ m/s}^2$)

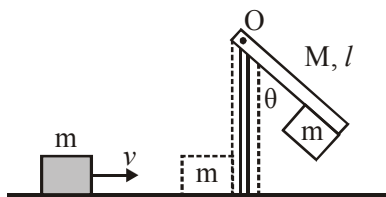

- (1) 69° (2) 63° (3) 55° (4) 49°

Sol. Angular momentum conservation

$$mv l = \frac{Ml^2}{3} \omega + ml^2 \omega$$

$$\Rightarrow \omega = \frac{1 \times 6 \times 1}{\frac{2}{3} + 1} = \frac{18}{5}$$

Now using energy conservation

$$\frac{1}{2} \left(M \frac{l^2}{3} \right) \omega^2 + \frac{1}{2} (ml^2) \omega^2$$

$$= (m + M) r_{cm} (1 - \cos \theta)$$

$$= (m + M) \left(\frac{ml + \frac{Ml}{2}}{m + M} \right) g (1 - \cos \theta)$$

$$\frac{5}{6} \times \left(\frac{18}{5} \right)^2 = 20 (1 - \cos \theta)$$

$$\Rightarrow 1 - \cos \theta = \frac{18}{5} \times \frac{3}{20}$$

$$\cos \theta = 1 - \frac{27}{50}$$

$$\cos \theta = \frac{23}{50} \Rightarrow \theta \approx 63^\circ$$

17. In a Young's double slit experiment, light of 500 nm is used to produce an interference pattern. When the distance between the slits is 0.05 mm, the angular width (in degree) of the fringes formed on the distance screen is close to :
(1) 0.07° (2) 0.17° (3) 1.7° (4) 0.57°

Official Ans. by NTA (4)

$$\text{Sol. } \Delta \theta_0 = \left(\frac{\lambda}{d} \times \frac{180}{\pi} \right)^\circ$$

18. Magnitude of magnetic field (in SI units) at the centre of a hexagonal shape coil of side 10 cm, 50 turns and carrying current I (Ampere) in units of $\frac{\mu_0 I}{\pi}$ is :

- (1) $250\sqrt{3}$ (2) $5\sqrt{3}$
 (3) $500\sqrt{3}$ (4) $50\sqrt{3}$

Official Ans. by NTA (3)

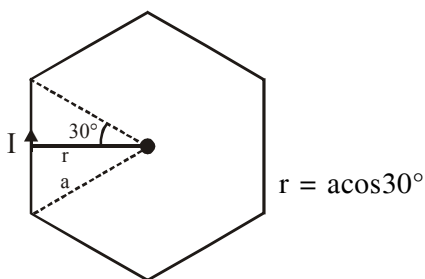

Sol.

$$B = \frac{6\mu_0 I}{4\pi a \cos 30^\circ} \times 2 \sin 30^\circ \times 50$$

$$= \frac{\mu_0 I}{\pi} \frac{150}{\sqrt{3}a} = \frac{50\sqrt{3}}{0.1} \frac{\mu_0 I}{\pi}$$

$$= 500\sqrt{3} \frac{\mu_0 I}{\pi}$$

19.

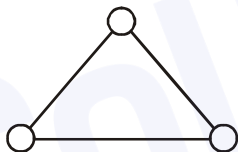

Consider a gas of triatomic molecules. The molecules are assumed to be triangular and made of massless rigid rods whose vertices are occupied by atoms. The internal energy of a mole of the gas at temperature T is :

- (1) $\frac{9}{2}RT$ (2) $\frac{3}{2}RT$
 (3) $\frac{5}{2}RT$ (4) $3RT$

Sol. $DOF = 3 + 3 = 6$

$$U = \frac{f}{2} nRT = 3RT$$

20. Two isolated conducting spheres S_1 and S_2 of radius $\frac{2}{3}R$ and $\frac{1}{3}R$ have $12 \mu C$ and $-3 \mu C$ charges, respectively, and are at a large distance from each other. They are now connected by a conducting wire. A long time after this is done the charges on S_1 and S_2 are respectively :

- (1) $6 \mu C$ and $3 \mu C$
 (2) $+4.5 \mu C$ and $-4.5 \mu C$
 (3) $3 \mu C$ and $6 \mu C$
 (4) $4.5 \mu C$ on both

Official Ans. by NTA (1)

Sol. Now

$$Q_1 + Q_2 = Q'_1 + Q'_2 = 12 \mu C - 3 \mu C = 9 \mu C$$

$$\& V_1 = V_2 \Rightarrow \frac{KQ'_1}{\frac{2R}{3}} = \frac{KQ'_2}{\frac{R}{3}}$$

$$Q'_1 = 2Q'_2 \Rightarrow 2Q'_2 + Q'_2 = 9 \mu C$$

$$\Rightarrow Q'_2 = 3 \mu C$$

$$\& Q'_1 = 6 \mu C$$

21. A bakelite beaker has volume capacity of 500 cc at $30^\circ C$. When it is partially filled with V_m volume (at 30°) of mercury, it is found that the unfilled volume of the beaker remains constant as temperature is varied. If $\gamma_{(beaker)} = 6 \times 10^{-6} \text{ } ^\circ C^{-1}$ and $\gamma_{(mercury)} = 1.5 \times 10^{-4} \text{ } ^\circ C^{-1}$, where γ is the coefficient of volume expansion, then V_m (in cc) is close to _____.

Official Ans. by NTA (20)

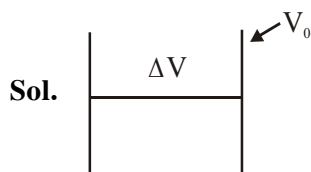

Sol.

$$\Delta V = (V_0 - V_m)$$

After increasing temperature

$$\Delta V' = (V'_0 - V'_m)$$

$$\Delta V' = \Delta V$$

$$V_0 - V_m = V_0(1 + \gamma_b \Delta T) - V_m (1 + \gamma_M \Delta T)$$

$$V_0 \gamma_b = V_m \gamma_m$$

$$V_m = \frac{V_0 \gamma_b}{\gamma_m} = \frac{(500)(6 \times 10^{-6})}{(1.5 \times 10^{-4})}$$

$$= 20 \text{ CC}$$

22. A cricket ball of mass 0.15 kg is thrown vertically up by a bowling machine so that it rises to a maximum height of 20 m after leaving the machine. If the part pushing the ball applies a constant force F on the ball and moves horizontally a distance of 0.2 m while launching the ball, the value of F (in N) is ($g = 10 \text{ ms}^{-2}$)_____.

Official Ans. by NTA (150)

Sol. $W_F = \frac{1}{2}mv^2 = mgh$

$$F(S) = mgh$$

$$F(0.2) = (0.15) (10) (20)$$

$$\boxed{F = 150\text{N}}$$

23. When a long glass capillary tube of radius 0.015 cm is dipped in a liquid, the liquid rises to a height of 15 cm within it. If the contact angle between the liquid and glass is close to 0° , the surface tension of the liquid, in milliNewton m^{-1} , is [$\rho_{\text{liquid}} = 900 \text{ kgm}^{-3}$, $g = 10 \text{ ms}^{-2}$] (Give answer in closest integer)_____.

Official Ans. by NTA (101)

Sol. Capillary rise

$$h = \frac{2S \cos \theta}{\rho g r}$$

$$S = \frac{\rho g r h}{2 \cos \theta}$$

$$S = 1012.5 \times 10^{-4}$$

$$S = 101.25 \times 10^{-3} = 101.25 \text{ mN/m}$$

In question closest integer is asked

so closest integer = 101.00 Ans.

24. A person of 80 kg mass is standing on the rim of a circular platform of mass 200 kg rotating about its axis as 5 revolutions per minute (rpm). The person now starts moving towards the centre of the platform. What will be the rotational speed (in rpm) of the platform when the person reaches its centre_____.

Official Ans. by NTA (9)

Sol. $L_i = L_f$

$$\left(80R^2 + \frac{200R^2}{2}\right)\omega = \left(0 + \frac{200R^2}{2}\right)\omega_1$$

$$180\omega_0 = 100\omega_1$$

$$\omega_1 = 1.8\omega_0 = 1.8 \times 5$$

$$= 9 \text{ rpm}$$

25. An observer can see through a small hole on the side of a jar (radius 15 cm) at a point at height of 15 cm from the bottom (see figure). The hole is at a height of 45 cm. When the jar is filled with a liquid up to a height of 30 cm the same observer can see the edge at the bottom of the jar. If the refractive index of the liquid is $N/100$, where N is an integer, the value of N is_____.

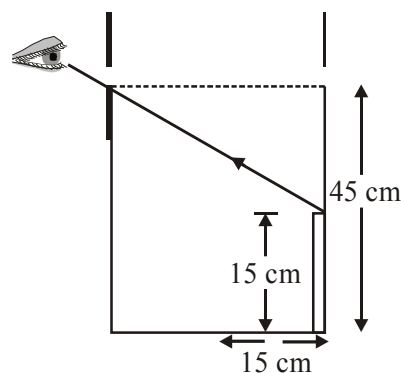

Sol. $\tan r = \frac{15}{30} = \frac{1}{2}$

$$\sin r = \frac{1}{\sqrt{5}}$$

$$1 \sin 45^\circ = \mu \sin r$$

$$\frac{1}{\sqrt{2}} = \mu \left(\frac{1}{\sqrt{5}} \right)$$

$$\mu = \frac{\sqrt{5}}{2} = 1.581$$

$$\frac{N}{100} = \mu$$

$$N = 100 \mu$$

$$N = 158.11$$

So integer value of N = 15800

