

PHYSICS

SECTION-A

1.

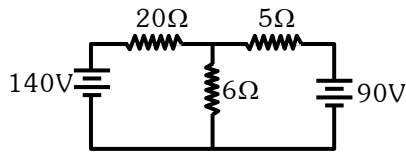

The value of current in the  $6\Omega$  resistance is :  
 (1) 4A (2) 8A (3) 10A (4) 6A

Official Ans. by NTA (3)

Sol.

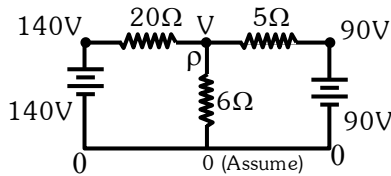

Applying KCL at point P,  
 $\frac{V-0}{6} + \frac{V-90}{5} + \frac{V-140}{20} = 0$   
 $\Rightarrow 10V + 12V - 1080 + 3V - 420 = 0$   
 $\Rightarrow V = 60$

$\therefore$  current in  $6\Omega = \frac{V-0}{6} = 10A$

Hence option 3.

2. The normal reaction 'N' for a vehicle of 800 kg mass, negotiating a turn on a  $30^\circ$  banked road at maximum possible speed without skidding is \_\_\_\_\_  $\times 10^3$  kg m/s<sup>2</sup>.

(1) 10.2 (2) 7.2 (3) 12.4 (4) 6.96

Official Ans. by NTA (1)

Sol.

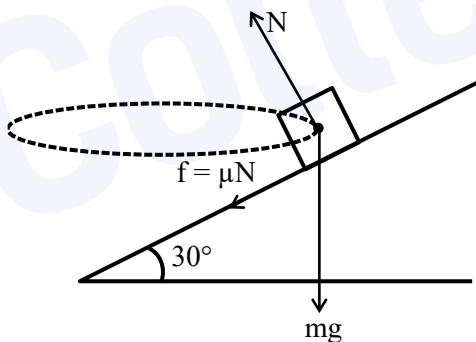

At  $v_{max}$ ,  $f$  will be limiting in nature.  
 $\therefore$  Balancing force in vertical direction,  
 $N \cos 30^\circ - mg - \mu N \cos 60^\circ = 0$   
 $\Rightarrow N [\cos 30^\circ - \mu \cos 60^\circ] = mg$   
 $\therefore N = \frac{800 \times 10}{(0.87 - 0.1)} \approx 10.2 \times 10^3 \text{ kg m/s}^2$

Hence option 1.

3.

A radioactive material decays by simultaneous emissions of two particles with half lives of 1400 years and 700 years respectively. What will be the time after the which one third of the material remains ? (Take  $\ln 3 = 1.1$ )

(1) 1110 years (2) 700 years  
 (3) 340 years (4) 740 years

Official Ans. by NTA (4)

Sol.

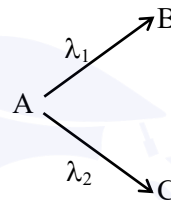

Given  $\lambda_1 = \frac{\ln 2}{700} / \text{year}$ ,  $\lambda_2 = \frac{\ln 2}{1400} / \text{year}$

$$\therefore \lambda_{net} = \lambda_1 + \lambda_2 = \ln 2 \left[ \frac{1}{700} + \frac{1}{1400} \right]$$

$$= \frac{3 \ln 2}{1400} / \text{year}$$

Now, Let initial no. of radioactive nuclei be

No.

$$\therefore \frac{N_0}{3} = N_0 e^{-\lambda_{net} t}$$

$$\Rightarrow \ln \frac{1}{3} = -\lambda_{net} t$$

$$\Rightarrow 1.1 = \frac{3 \times 0.693}{1400} t \Rightarrow t \approx 740 \text{ years}$$

Hence option 4

4. A steel block of 10 kg rests on a horizontal floor as shown. When three iron cylinders are placed on it as shown, the block and cylinders go down with an acceleration  $0.2 \text{ m/s}^2$ . The normal reaction  $R'$  by the floor if mass of the iron cylinders are equal and of 20 kg each, is \_\_\_\_\_ N. [Take  $g = 10 \text{ m/s}^2$  and  $\mu_s = 0.2$ ]

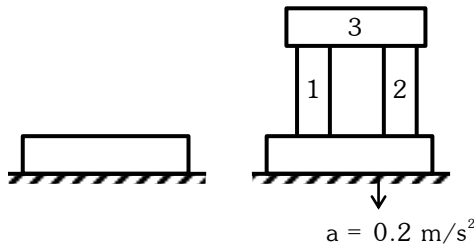

- (1) 716      (2) 686      (3) 714      (4) 684

Official Ans. by NTA (2)

Sol.

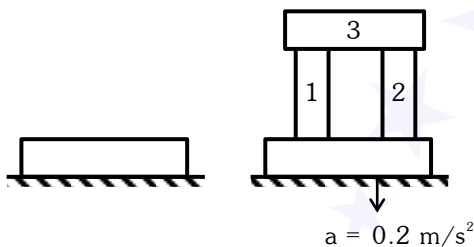

Writing force equation in vertical direction

$$Mg - N = Ma$$

$$\Rightarrow 70g - N = 70 \times 0.2$$

$$\Rightarrow N = 70 [g - 0.2] = 70 \times 9.8$$

$$\therefore N = 686 \text{ Newton}$$

Note : Since there is no compressive normal from the sides, hence friction will not act.

Hence option 2.

5. AC voltage  $V(t) = 20 \sin \omega t$  of frequency 50 Hz is applied to a parallel plate capacitor. The separation between the plates is 2 mm and the area is  $1 \text{ m}^2$ . The amplitude of the oscillating displacement current for the applied AC voltage is \_\_\_\_\_. [Take  $\epsilon_0 = 8.85 \times 10^{-12} \text{ F/m}$ ]

- (1) 21.14  $\mu\text{A}$                       (2) 83.37  $\mu\text{A}$   
 (3) 27.79  $\mu\text{A}$                       (4) 55.58  $\mu\text{A}$

Official Ans. by NTA (3)

Sol.

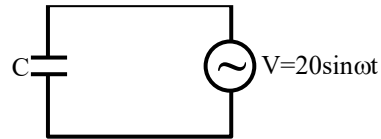

From the given information,

$$C = \frac{\epsilon_0 A}{d} = \frac{\epsilon_0 \times 1}{2 \times 10^{-3}} \text{ F}$$

$$\therefore X_C = \frac{1}{\omega C} = \frac{2 \times 10^{-3}}{2 \times 50\pi \times \epsilon_0} = \frac{2 \times 10^{-3}}{25 \times 4\pi \epsilon_0} \Omega$$

$$\therefore X_C = \frac{2 \times 10^{-3}}{25} \times 9 \times 10^9 = \frac{18}{25} \times 10^6 \Omega$$

$$\therefore i_0 = \frac{V_0}{X_C} = \frac{20 \times 25}{18} \times 10^{-6} \text{ A} = 27.47 \mu\text{A}.$$

The value of amplitude of displacement current will be same as value of amplitude of conventional current.

Hence option 3.

6. Region I and II are separated by a spherical surface of radius 25 cm. An object is kept in region I at a distance of 40 cm from the surface. The distance of the image from the surface is :

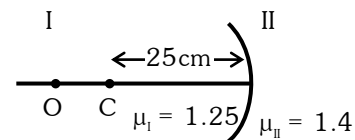

- (1) 55.44 cm                      (2) 9.52 cm  
 (3) 18.23 cm                      (4) 37.58 cm

Official Ans. by NTA (4)

Sol. 
$$\frac{\mu_2}{v} - \frac{\mu_1}{u} = \frac{\mu_2 - \mu_1}{R}$$

$$\frac{1.4}{v} - \frac{1.25}{-40} = \frac{1.4 - 1.25}{-25}$$

$$\frac{1.4}{v} = -\frac{0.15}{25} - \frac{1.25}{40}$$

$$v = -37.58 \text{ cm}$$

Hence option (4)

7. A person whose mass is 100 kg travels from Earth to Mars in a spaceship. Neglect all other objects in sky and take acceleration due to gravity on the surface of the Earth and Mars as  $10 \text{ m/s}^2$  and  $4 \text{ m/s}^2$  respectively. Identify from the below figures, the curve that fits best for the weight of the passenger as a function of time.

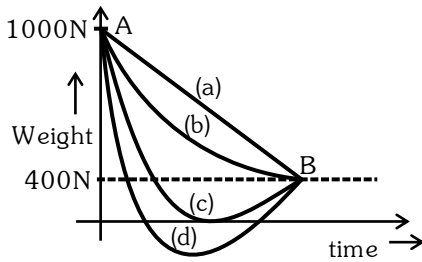

- (1) (c)      (2) (a)      (3) (d)      (4) (b)

**Official Ans. by NTA (1)**

**Sol.** At neutral point  $g = 0$  so graph (C) is correct  
Hence option (1).

8. The amount of heat needed to raise the temperature of 4 moles of a rigid diatomic gas from  $0^\circ\text{C}$  to  $50^\circ\text{C}$  when no work is done is \_\_\_\_\_. (R is the universal gas constant)

- (1) 250 R    (2) 750 R    (3) 175 R    (4) 500 R

**Official Ans. by NTA (4)**

**Sol.**  $\Delta Q = \Delta U + \Delta W$

Here  $\Delta W = 0$

$\Delta Q = \Delta U = nC_V\Delta T$

$$\Delta Q = 4 \times \frac{5R}{2} (50) = 500R$$

Hence option (4).

9. If  $\vec{A}$  and  $\vec{B}$  are two vectors satisfying the relation  $\vec{A} \cdot \vec{B} = |\vec{A} \times \vec{B}|$ . Then the value of  $|\vec{A} - \vec{B}|$  will be :

- (1)  $\sqrt{A^2 + B^2}$                       (2)  $\sqrt{A^2 + B^2 + \sqrt{2}AB}$   
(3)  $\sqrt{A^2 + B^2 + 2AB}$                 (4)  $\sqrt{A^2 + B^2 - \sqrt{2}AB}$

**Sol.**  $\vec{A} \cdot \vec{B} = |\vec{A} \times \vec{B}|$

$$AB\cos\theta = AB\sin\theta \Rightarrow \theta = 45^\circ$$

$$|\vec{A} - \vec{B}| = \sqrt{A^2 + B^2 - 2AB\cos 45^\circ}$$

$$= \sqrt{A^2 + B^2 - \sqrt{2}AB}$$

Hence option (4).

10. A deuteron and an alpha particle having equal kinetic energy enter perpendicular into a magnetic field. Let  $r_d$  and  $r_\alpha$  be their respective radii of circular path. The value of  $\frac{r_d}{r_\alpha}$  is equal to :

- (1)  $\frac{1}{\sqrt{2}}$                                       (2)  $\sqrt{2}$   
(3) 1    (4) 2

**Official Ans. by NTA (2)**

**Sol.**  $r = \frac{mv}{qB} = \frac{\sqrt{2mk}}{qB}$

$$\frac{r_d}{r_\alpha} = \sqrt{\frac{m_d}{m_\alpha} \frac{q_\alpha}{q_d}} = \sqrt{\frac{2}{4} \left(\frac{2}{1}\right)} = \sqrt{2}$$

Hence option (2).

11. A nucleus of mass M emits  $\gamma$ -ray photon of frequency ' $\nu$ '. The loss of internal energy by the nucleus is :

[Take 'c' as the speed of electromagnetic wave]

- (1)  $h\nu$                                         (2) 0  
(3)  $h\nu \left[1 - \frac{h\nu}{2Mc^2}\right]$                 (4)  $h\nu \left[1 + \frac{h\nu}{2Mc^2}\right]$

**Official Ans. by NTA (4)**

**Sol.** Energy of  $\gamma$  ray  $[E_\gamma] = h\nu$

$$\text{Momentum of } \gamma \text{ ray } [P_\gamma] = \frac{h}{\lambda} = \frac{h\nu}{c}$$

Total momentum is conserved.

$$\vec{P}_\gamma + \vec{P}_{\text{Nu}} = 0$$

Where  $\vec{P}_{\text{Nu}}$  = Momentum of decayed nuclei

$$\Rightarrow P_\gamma = P_{\text{Nu}}$$

$$\Rightarrow \frac{h\nu}{c} = P_{\text{Nu}}$$

$\Rightarrow$  K.E. of nuclei

$$= \frac{1}{2} Mv^2 = \frac{(P_{\text{Nu}})^2}{2M} = \frac{1}{2M} \left[ \frac{h\nu}{c} \right]^2$$

Loss in internal energy =  $E_\gamma + \text{K.E.}_{\text{Nu}}$

$$= h\nu + \frac{1}{2M} \left[ \frac{h\nu}{c} \right]^2$$

$$= h\nu \left[ 1 + \frac{h\nu}{2Mc^2} \right]$$

12. A certain charge  $Q$  is divided into two parts  $q$  and  $(Q-q)$ . How should the charges  $Q$  and  $q$  be divided so that  $q$  and  $(Q-q)$  placed at a certain distance apart experience maximum electrostatic repulsion ?

- (1)  $Q = \frac{q}{2}$                       (2)  $Q = 2q$   
 (3)  $Q = 4q$                       (4)  $Q = 3q$

Official Ans. by NTA (2)

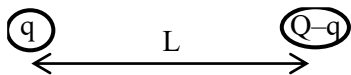

Sol.

$$F_q = \frac{kq(Q-q)}{L^2} = \frac{k}{L^2}(qQ - q^2)$$

$$\frac{dF}{dq} = 0 \text{ when force is maximum}$$

$$\frac{dF}{dq} = \frac{k}{L^2}[Q - 2q] = 0$$

$$\Rightarrow Q - 2q = 0 \Rightarrow Q = 2q$$

13. A current of 5 A is passing through a non-linear magnesium wire of cross-section  $0.04 \text{ m}^2$ . At every point the direction of current density is at an angle of  $60^\circ$  with the unit vector of area of cross-section. The magnitude of electric field at every point of the conductor is :

(Resistivity of magnesium  $\rho = 44 \times 10^{-8} \Omega\text{m}$ )

- (1)  $11 \times 10^{-2} \text{ V/m}$                       (2)  $11 \times 10^{-7} \text{ V/m}$   
 (3)  $11 \times 10^{-5} \text{ V/m}$                       (4)  $11 \times 10^{-3} \text{ V/m}$

Official Ans. by NTA (3)

Sol.  $I = \vec{J} \cdot \vec{A} = JA \cos(\theta)$

$$5 = J \left( \frac{4}{100} \right) \times \cos(60)$$

$$J = 5 \times 50 = 250 \text{ A/m}^2$$

$$\text{Now, } \vec{E} = \rho \cdot \vec{J}$$

$$= 44 \times 10^{-8} \times 250 = 11 \times 10^{-5} \text{ V/m}$$

14. Consider a mixture of gas molecule of types A, B and C having masses  $m_A < m_B < m_C$ . The ratio of their root mean square speeds at normal temperature and pressure is :

- (1)  $v_A = v_B = v_C = 0$                       (2)  $\frac{1}{v_A} > \frac{1}{v_B} > \frac{1}{v_C}$   
 (3)  $v_A = v_B \neq v_C$                       (4)  $\frac{1}{v_A} < \frac{1}{v_B} < \frac{1}{v_C}$

Official Ans. by NTA (4)

Sol.  $V_{\text{RMS}} = \sqrt{\frac{3RT}{M}}$

$$m_A < m_B < m_C$$

$$\Rightarrow v_A > v_B > v_C$$

$$\Rightarrow \frac{1}{v_A} < \frac{1}{v_B} < \frac{1}{v_C}$$

15. A butterfly is flying with a velocity  $4\sqrt{2} \text{ m/s}$  in North-East direction. Wind is slowly blowing at  $1 \text{ m/s}$  from North to South. The resultant displacement of the butterfly in 3 seconds is :

- (1) 3 m                      (2) 20 m  
 (3)  $12\sqrt{2} \text{ m}$                       (4) 15 m

Official Ans. by NTA (4)

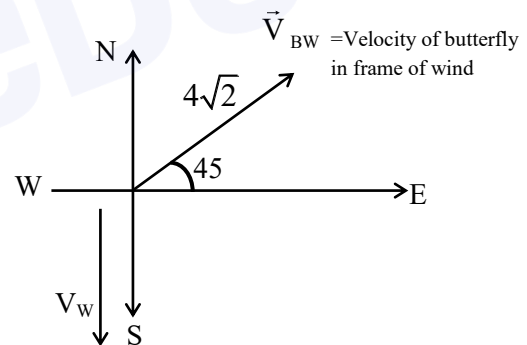

Sol.

$$\vec{V}_{\text{BW}} = 4\sqrt{2} \cos 45^\circ \hat{i} + 4\sqrt{2} \sin 45^\circ \hat{j}$$

$$= 4\hat{i} + 4\hat{j}$$

$$\vec{V}_w = -\hat{j}$$

$$\vec{V}_B = \vec{V}_{\text{BW}} + \vec{V}_w = 4\hat{i} + 3\hat{j}$$

$$\vec{S}_B = \vec{V}_B \times t = (4\hat{i} + 3\hat{j}) \times 3 = 12\hat{i} + 9\hat{j}$$

$$|\vec{S}_B| = \sqrt{(12)^2 + (9)^2} = 15 \text{ m}$$

16. The value of tension in a long thin metal wire has been changed from  $T_1$  to  $T_2$ . The lengths of the metal wire at two different values of tension  $T_1$  and  $T_2$  are  $l_1$  and  $l_2$  respectively. The actual length of the metal wire is :

- (1)  $\frac{T_1 l_2 - T_2 l_1}{T_1 - T_2}$       (2)  $\frac{T_1 l_1 - T_2 l_2}{T_1 - T_2}$   
 (3)  $\frac{l_1 + l_2}{2}$       (4)  $\sqrt{T_1 T_2 l_1 l_2}$

**Official Ans. by NTA (1)**

**Sol.**  $Y = \frac{FL}{A\Delta L}$   
 $\Rightarrow Y = \frac{T_1 l_0}{A(l_1 - l_0)} = \frac{T_2 l_0}{A(l_2 - l_0)}$

$l = \frac{T_1(l_2 - l_0)}{T_2(l_1 - l_0)}$

$T_2 l_1 - T_2 l_0 = T_1 l_2 - T_1 l_0$

$(T_1 - T_2)l_0 = T_1 l_2 - T_2 l_1$

$l_0 = \left( \frac{T_1 l_2 - T_2 l_1}{T_1 - T_2} \right)$

17. For the circuit shown below, calculate the value of  $I_Z$  :

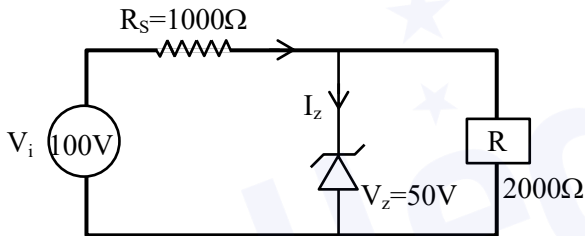

- (1) 25 mA      (2) 0.15 A  
 (3) 0.1 A      (4) 0.05 A

**Official Ans. by NTA (1)**

**Sol.**  $I = \frac{50}{1000} = 50\text{mA}$

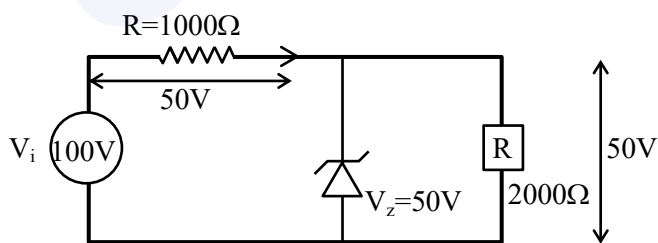

$I = \frac{50}{2000} = 25\text{mA}$

$I_Z = I_{1000} - I_{2000}$   
 $= 50 - 25 = 25\text{ mA}$

18. The arm PQ of a rectangular conductor is moving from  $x = 0$  to  $x = 2b$  outwards and then inwards from  $x = 2b$  to  $x = 0$  as shown in the figure. A uniform magnetic field perpendicular to the plane is acting from  $x = 0$  to  $x = b$ . Identify the graph showing the variation of different quantities with distance :

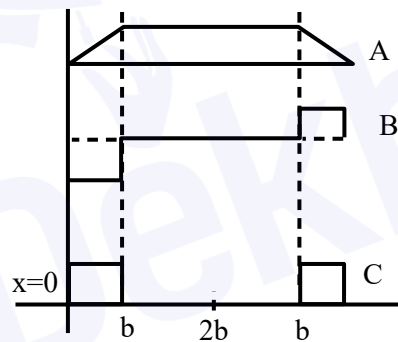
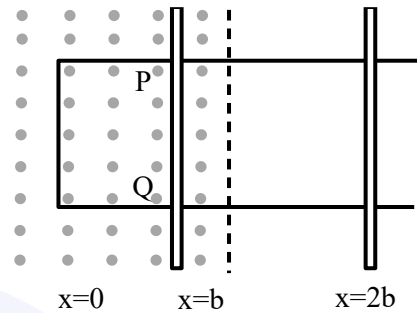

- (1) A-Flux, B-Power dissipated, C-EMF  
 (2) A-Power dissipated, B-Flux, C-EMF  
 (3) A-Flux, B-EMF, C-Power dissipated  
 (4) A-EMF, B-Power dissipated, C-Flux

**Official Ans. by NTA (3)**

**Sol.** As rod moves in field area increases upto  $x = b$  then field is absent and again flux is generated on return journey from  $x = b$  to  $x = 0$ . Thus plot A for flux.

$\Rightarrow e = -\frac{d\phi}{dt} \Rightarrow$  curve B for emf

$\Rightarrow$  Power dissipated =  $vi \Rightarrow$  curve C for power dissipated

19. The entropy of any system is given by

$$S = \alpha^2 \beta \ln \left[ \frac{\mu k R}{J \beta^2} + 3 \right]$$

where  $\alpha$  and  $\beta$  are the constants.  $\mu$ ,  $J$ ,  $k$  and  $R$  are no. of moles, mechanical equivalent of heat, Boltzmann constant and gas constant respectively.

$$\left[ \text{Take } S = \frac{dQ}{T} \right]$$

Choose the incorrect option from the following :

- (1)  $\alpha$  and  $J$  have the same dimensions.
- (2)  $S$ ,  $\beta$ ,  $k$  and  $\mu R$  have the same dimensions.
- (3)  $S$  and  $\alpha$  have different dimensions.
- (4)  $\alpha$  and  $k$  have the same dimensions.

**Official Ans. by NTA (4)**

**Sol.** 
$$S = \alpha^2 \beta \ln \left( \frac{\mu k R}{J \beta^2} + 3 \right)$$

$$S = \frac{Q}{T} = \text{joule} / \text{K}$$

$$[\alpha^2 \beta] = \text{Joule} / \text{K}$$

$$PV = nRT \quad \left[ \frac{\mu k R}{J \beta^2} \right] = 1$$

$$R = \frac{\text{Joule}}{\text{K}}$$

$$\Rightarrow R = \frac{\text{Joule}}{\text{K}}, K = \frac{\text{Joule}}{R}$$

$$\Rightarrow \beta = \left( \frac{\text{Joule}}{\text{K}} \right)$$

$$\alpha^2 \beta = \left( \frac{\text{Joule}}{\text{K}} \right)$$

$$\Rightarrow \alpha = \text{dimensionless}$$

20. The radiation corresponding to  $3 \rightarrow 2$  transition of a hydrogen atom falls on a gold surface to generate photoelectrons. These electrons are passed through a magnetic field of  $5 \times 10^{-4}$  T. Assume that the radius of the largest circular path followed by these electrons is 7 mm, the work function of the metal is :

(Mass of electron =  $9.1 \times 10^{-31}$  kg)

- (1) 1.36 eV
- (2) 1.88 eV
- (3) 0.16 eV
- (4) 0.82 eV

**Official Ans. by NTA (4)**

**Sol.**  $1.51 \text{ --- } n = 3$   
 $3.4 \text{ --- } n =$   
 $13.6 \text{ --- } n = 1$

$$3 \rightarrow 2 \Rightarrow 1.89 \text{ eV}$$

$$5 \times 10^{-4} \text{ T} \quad r = 7 \text{ mm}$$

$$r = \frac{mv}{qB} \Rightarrow mv = qrB$$

$$\Rightarrow E = \frac{p^2}{2m} = \frac{(qRB)^2}{2m}$$

$$= \frac{(1.6 \times 10^{-19} \times 7 \times 10^{-3} \times 5 \times 10^{-4})^2}{2 \times 9.1 \times 10^{-31} \text{ Joule}}$$

$$= \frac{3136 \times 10^{-52}}{18.2 \times 10^{-31} \times 1.6 \times 10^{-19}} \text{ eV}$$

$$= 1.077 \text{ eV}$$

We know work function = energy incident -  $(KE)_{\text{electron}}$

$$\phi = 1.89 - 1.077 = 0.813 \text{ eV}$$

**SECTION-B**

1. In a spring gun having spring constant 100 N/m a small ball 'B' of mass 100 g is put in its barrel (as shown in figure) by compressing the spring through 0.05 m. There should be a box placed at a distance 'd' on the ground so that the ball falls in it. If the ball leaves the gun horizontally at a height of 2 m above the ground. The value of d is \_\_\_\_ m. ( $g = 10 \text{ m/s}^2$ )

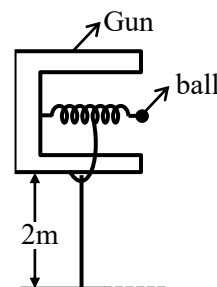

**Official Ans. by NTA (1)**

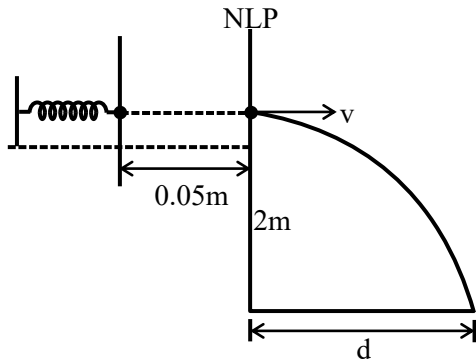

Sol.

$$\frac{1}{2}kx^2 = \frac{1}{2}mv^2$$

$$Kx^2 = mv^2$$

$$v = x\sqrt{\frac{k}{m}} = 0.05\sqrt{\frac{100}{0.1}} = 0.05 \times 10\sqrt{10}$$

$$v = 0.5\sqrt{10}$$

$$\text{From } h = \frac{1}{2}gt^2$$

$$t = \sqrt{\frac{2h}{g}} = \sqrt{\frac{2 \times 2}{10}} = \frac{2}{\sqrt{10}}$$

$$\therefore d = vt = 0.5\sqrt{10} \times \frac{2}{\sqrt{10}} = 1\text{m}$$

2. In an LCR series circuit, an inductor 30 mH and a resistor 1  $\Omega$  are connected to an AC source of angular frequency 300 rad/s. The value of capacitance for which, the current leads the voltage by  $45^\circ$  is  $\frac{1}{x} \times 10^{-3}$  F. Then the value of x is \_\_\_\_.

**Official Ans. by NTA (3)**

$$\text{Sol. } \tan \phi = \frac{X_C - X_L}{R}$$

$$\tan 45 = \frac{X_C - X_L}{R}$$

$$X_C - X_L = R$$

$$\frac{1}{\omega C} - \omega L = R$$

$$\frac{1}{\omega C} - 300 \times 0.03 = 1$$

$$\frac{1}{\omega C} = 10$$

$$C = \frac{1}{10\omega} = \frac{1}{10 \times 300}$$

$$C = \frac{1}{3} \times 10^{-3}$$

$$X = 3$$

3. The amplitude of wave disturbance propagating in the positive x-direction is given by  $y = \frac{1}{(1+x)^2}$  at time  $t = 0$  and  $y = \frac{1}{1+(x-2)^2}$  at  $t = 1$ s, where x and y are in metres. The shape of wave does not change during the propagation. The velocity of the wave will be \_\_\_\_ m/s.

**Official Ans. by NTA (2)**

$$\text{Sol. At } t = 0, y = \frac{1}{1+x^2}$$

$$\text{At time } t = t, y = \frac{1}{1+(x-vt)^2}$$

$$\text{At } t = 1, y = \frac{1}{1+(x-v)^2} \dots (i)$$

$$\text{At } t = 1, y = \frac{1}{1+(x-2)^2} \dots (ii)$$

Comparing (i) & (ii)

$$v = 2\text{m/s}$$

4. A body having specific charge  $8 \mu\text{C/g}$  is resting on a frictionless plane at a distance 10 cm from the wall (as shown in the figure). It starts moving towards the wall when a uniform electric field of 100 V/m is applied horizontally towards the wall. If the collision of the body with the wall is perfectly elastic, then the time period of the motion will be \_\_\_\_ s.

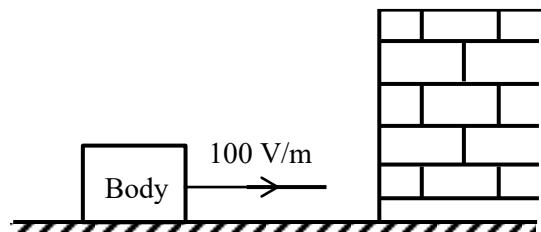

**Official Ans. by NTA (1)**

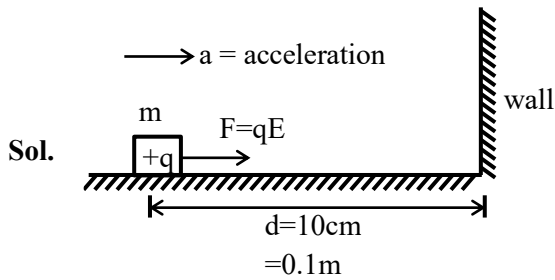

$$F = ma$$

$$qE = ma$$

$$a = \frac{qE}{m}$$

$$\text{Now } d = \frac{1}{2} at^2$$

$$t = \sqrt{\frac{2d}{a}}$$

$$t = \sqrt{\frac{2d}{\left(\frac{qE}{m}\right)}}$$

$$t = \sqrt{\frac{2 \times 0.1}{\left(\frac{8 \times 10^{-6}}{10^{-3}}\right) \times 100}} = \frac{1}{2}$$

$$\therefore \text{Time period} = 2t = 1 \text{ sec}$$

$$\text{Ans.} = 1.00$$

5. In the reported figure, heat energy absorbed by a system in going through a cyclic process is \_\_\_\_\_  $\pi \text{ J}$ .

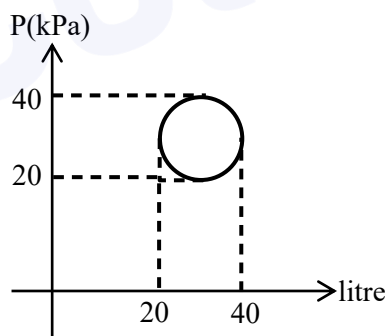

Official Ans. by NTA (100)

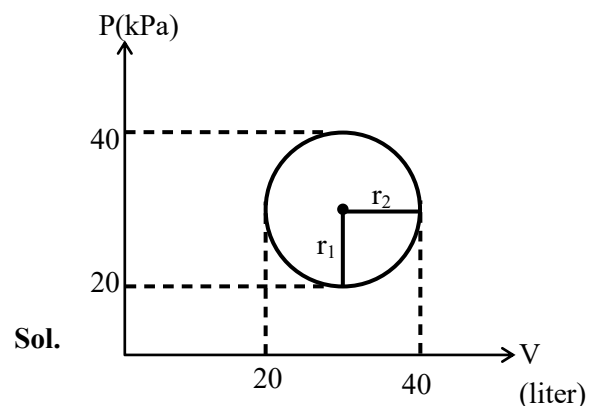

For complete cyclic process

$$\Delta U = 0$$

$$\therefore \text{from } \Delta Q = \Delta U + W$$

$$= 0 + W$$

$$\Delta Q = W$$

$$= \text{Area}$$

$$= \pi r_1 \cdot r_2$$

$$= \pi \times (10 \times 10^3) \times (10 \times 10^3)$$

$$\Delta Q = 100 \pi$$

$$\therefore \text{Ans.} = 100$$

6. A circular disc reaches from top to bottom of an inclined plane of length 'L'. When it slips down the plane, it takes time ' $t_1$ '. When it rolls down the plane, it takes time  $t_2$ . The value of  $\frac{t_2}{t_1}$  is  $\sqrt{\frac{3}{x}}$ . The value of x will be \_\_\_\_\_.

Official Ans. by NTA (2)



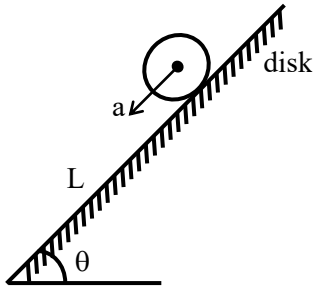

Sol.

If disk slips on inclined plane, then its acceleration

$$a_1 = g \sin \theta$$

$$L = \frac{1}{2} a_1 t_1^2$$

$$\Rightarrow t_1 = \sqrt{\frac{2L}{a_1}} \quad \dots (i)$$

If disk rolls on inclined plane, its acceleration,

$$a_2 = \frac{g \sin \theta}{1 + \frac{I}{mR^2}}$$

$$a_2 = \frac{g \sin \theta}{1 + \frac{mR^2}{2mR^2}}$$

$$a_2 = \frac{2}{3} g \sin \theta$$

$$\text{Now } L = \frac{1}{2} a_2 \cdot t_2^2$$

$$\Rightarrow t_2 = \sqrt{\frac{2L}{a_2}} \quad \dots (ii)$$

$$\text{Now } \frac{t_2}{t_1} = \sqrt{\frac{a_1}{a_2}} = \sqrt{\frac{3}{2}}$$

$$\Rightarrow x = 2$$

7. A rod of mass  $M$  and length  $L$  is lying on a horizontal frictionless surface. A particle of mass ' $m$ ' travelling along the surface hits at one end of the rod with a velocity ' $u$ ' in a direction perpendicular to the rod. The collision is completely elastic. After collision, particle comes to rest. The ratio of masses  $\left(\frac{m}{M}\right)$  is  $\frac{1}{x}$ . The value of ' $x$ ' will be \_\_\_\_\_.

**Official Ans. by NTA (4)**

Sol.

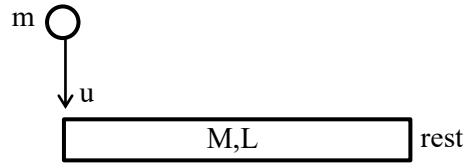

Just before collision

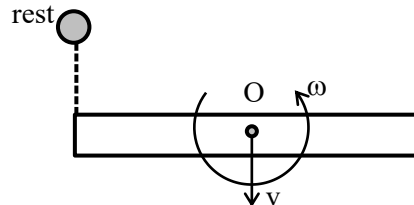

Just after collision

From momentum conservation,  $P_i^0 = P_f$

$$mu = Mv \quad \dots (i)$$

From angular momentum conservation about O,

$$mu \cdot \frac{L}{2} = \frac{ML^2}{12} \omega$$

$$\Rightarrow \omega = \frac{6mu}{ML} \quad \dots (ii)$$

From  $e = \frac{R.V.S}{L.V.S}$

$$1 = \frac{v + \frac{\omega L}{2}}{u}$$

$$v + \frac{\omega L}{2} = u$$

$$v + \frac{3mu}{M} = u$$

$$\frac{mu}{M} + \frac{3mu}{M} = u$$

$$\frac{4mu}{M} = u$$

$$\frac{m}{M} = \frac{1}{4}$$

$$X = 4$$

8. An object viewed from a near point distance of 25 cm, using a microscopic lens with magnification '6', gives an unresolved image. A resolved image is observed at infinite distance with a total magnification double the earlier using an eyepiece along with the given lens and a tube of length 0.6 m, if the focal length of the eyepiece is equal to \_\_\_\_\_ cm.

**Official Ans. by NTA (25)**

**Sol.** For simple microscope,

$$m = 1 + \frac{D}{f_0}$$

$$6 = 1 + \frac{D}{f_0}$$

$$5 = \frac{25}{f_0}$$

$$f_0 = 5 \text{ cm}$$

For compound microscope,

$$m = \frac{\ell \cdot D}{f_0 \cdot f_c}$$

$$12 = \frac{60 \times 25}{5 \cdot f_c}$$

$$f_c = 25 \text{ cm}$$

9. The frequency of a car horn encountered a change from 400 Hz to 500 Hz. When the car approaches a vertical wall. If the speed of sound is 330 m/s. Then the speed of car is \_\_\_\_\_ km/h.

**Official Ans. by NTA (132)**

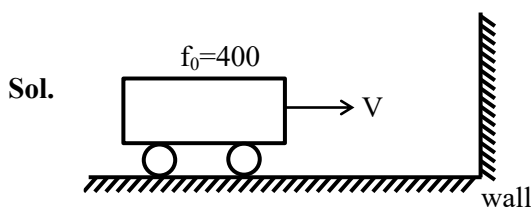

Wall as an observer

Frequency received by wall

$$f_1 = f_0 \left( \frac{C}{C - V} \right)$$

Again wall as a source

Frequency received by observer on car

$$f_2 = f_1 \left( \frac{C + V}{C} \right)$$

$$f_2 = f_0 \left( \frac{C + V}{C - V} \right)$$

$$500 = 400 \left( \frac{C + V}{C - V} \right)$$

$$\frac{5}{4} = \frac{C + V}{C - V}$$

$$C = 9V$$

$$V = \frac{C}{9} = \frac{330}{9} \text{ m/s}$$

$$V = \frac{330}{9} \times \frac{18}{5} = 132 \text{ km/hr}$$

10. A carrier wave  $V_C(t) = 160 \sin(2\pi \times 10^6 t)$  volts is made to vary between  $V_{\max} = 200 \text{ V}$  and  $V_{\min} = 120 \text{ V}$  by a message signal  $V_m(t) = A_m \sin(2\pi \times 10^3 t)$  volts. The peak voltage  $A_m$  of the modulating signal is \_\_\_\_\_.

**Official Ans. by NTA (40)**

**Sol.** Maximum amplitude

$$A_{\max} = A_m + A_C$$

$$\Rightarrow V_{\max} = V_m + V_C$$

$$200 = V_m + 160$$

$$V_m = 40$$

$$\therefore \text{Peak voltage } A_m = 40$$

Ans. 40s