

PHYSICS

SECTION-A

1. In a circuit consisting of a capacitance and a generator with alternating emf $E_g = E_{g_0} \sin \omega t$, V_c and I_c are the voltage and current. Correct phasor diagram for such circuit is :

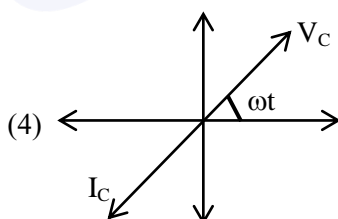
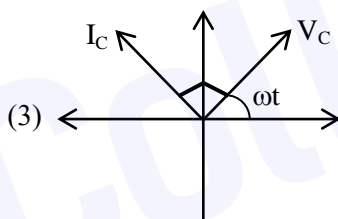
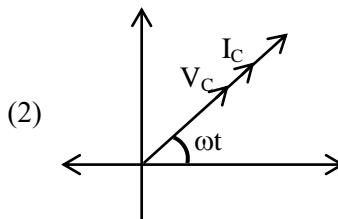
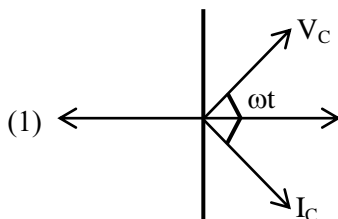
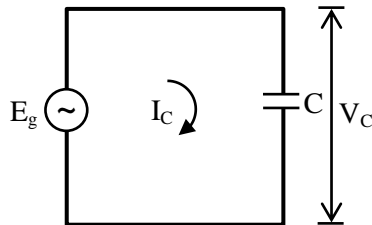

Official Ans. by NTA (3)

Sol. In capacitor, current lead voltage by $\frac{\pi}{2}$

2. A Copper (Cu) rod of length 25 cm and cross-sectional area 3 mm^2 is joined with a similar Aluminium (Al) rod as shown in figure. Find the resistance of the combination between the ends A and B.

(Take Resistivity of Copper = $1.7 \times 10^{-8} \Omega \text{m}$
Resistivity of Aluminium = $2.6 \times 10^{-8} \Omega \text{m}$)

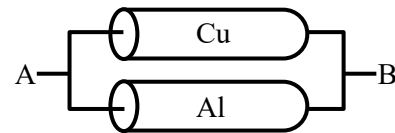

- (1) 2.170 mΩ (2) 1.420 mΩ
(3) 0.0858 mΩ (4) 0.858 mΩ

Official Ans. by NTA (4)

Sol. $R = \frac{R_1 R_2}{R_1 + R_2} = \frac{\ell}{A} \cdot \frac{\rho_1 \rho_2}{\rho_1 + \rho_2}$
 $R = \frac{25 \times 10^{-2}}{3 \times 10^{-6}} \times \frac{1.7 \times 2.6 \times 10^{-16}}{4.3 \times 10^{-8}}$
 $R = 0.858 \text{ m}\Omega$

3. What will be the projection of vector $\vec{A} = \hat{i} + \hat{j} + \hat{k}$ on vector $\vec{B} = \hat{i} + \hat{j}$?

- (1) $\sqrt{2}(\hat{i} + \hat{j} + \hat{k})$ (2) $2(\hat{i} + \hat{j} + \hat{k})$
(3) $\sqrt{2}(\hat{i} + \hat{j})$ (4) $(\hat{i} + \hat{j})$

Official Ans. by NTA (4)

Sol. $(A \cos \theta) \vec{B} = A \left(\frac{\vec{A} \cdot \vec{B}}{AB} \right) \vec{B} = \frac{\vec{A} \cdot \vec{B}}{B} \vec{B}$
 $= \frac{2}{\sqrt{2}} \left(\frac{\vec{i} + \vec{j}}{\sqrt{2}} \right) = \vec{i} + \vec{j}$

4. A porter lifts a heavy suitcase of mass 80 kg and at the destination lowers it down by a distance of 80 cm with a constant velocity. Calculate the workdone by the porter in lowering the suitcase.

(take $g = 9.8 \text{ ms}^{-2}$)

- (1) -62720.0 J (2) -627.2 J
(3) +627.2 J (4) 784.0 J

Official Ans. by NTA (2)

Sol. $W_{\text{Porter}} + W_{\text{mg}} = \Delta K.E. = 0$
 $W_{\text{Porter}} = -W_{\text{mg}} = -mgh$
 $= -80 \times 9.8 \times .8 = -627.2 \text{ J}$

5. T_0 is the time period of a simple pendulum at a place. If the length of the pendulum is reduced to $\frac{1}{16}$ times of its initial value, the modified time period is :

- (1) T_0 (2) $8\pi T_0$
 (3) $4T_0$ (4) $\frac{1}{4}T_0$

Official Ans. by NTA (4)

Sol. $T_0 = 2\pi\sqrt{\frac{\ell}{g}}$

New time period $T = 2\pi\sqrt{\frac{\ell/16}{g}} = \frac{2\pi}{4}\sqrt{\frac{\ell}{g}}$

$T = \frac{T_0}{4}$

6. A ray of light passes from a denser medium to a rarer medium at an angle of incidence i . The reflected and refracted rays make an angle of 90° with each other. The angle of reflection and refraction are respectively r and r' . The critical angle is given by :

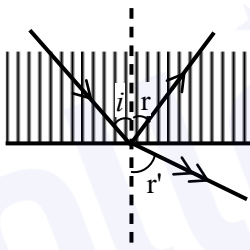

- (1) $\sin^{-1}(\cot r)$ (2) $\tan^{-1}(\sin i)$
 (3) $\sin^{-1}(\tan r')$ (4) $\sin^{-1}(\tan r)$

Official Ans. by NTA (4)

Sol. $r + r' + 90^\circ = 180^\circ \Rightarrow r' = 90 - r = 90 - i$

$n_1 \sin i = n_2 \sin r' = n_2 \sin (90 - i)$

$n_1 \sin i = n_2 \cos i \Rightarrow \tan i = \frac{n_2}{n_1}$

Now $\sin C = \frac{n_2}{n_1} = \tan i$

$\Rightarrow C = \sin^{-1}(\tan i) = \sin^{-1}(\tan r)$

7. **Statement I :** The ferromagnetic property depends on temperature. At high temperature, ferromagnet becomes paramagnet.

Statement II : At high temperature, the domain wall area of a ferromagnetic substance increases.

In the light of the above statements, choose the **most appropriate** answer from the options given below :

- (1) **Statement I** is true but **Statement II** is false
 (2) Both **Statement I** and **Statement II** are true
 (3) Both **Statement I** and **Statement II** are false
 (4) **Statement I** is false but **Statement II** is true

Official Ans. by NTA (1)

Sol. As temperature increases, domains disintegrate so ferromagnetism decreases and above curie temperature it become paramagnet.

8. A bullet of '4g' mass is fired from a gun of mass 4 kg. If the bullet moves with the muzzle speed of 50 ms^{-1} , the impulse imparted to the gun and velocity of recoil of gun are :

- (1) 0.4 kg ms^{-1} , 0.1 ms^{-1}
 (2) 0.2 kg ms^{-1} , 0.05 ms^{-1}
 (3) 0.2 kg ms^{-1} , 0.1 ms^{-1}
 (4) 0.4 kg ms^{-1} , 0.05 ms^{-1}

Official Ans. by NTA (2)

Sol.

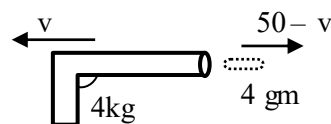

By momentum conservation

$4 \times 10^{-3} (50 - v) - 4v = 0$

$v = \frac{4 \times 10^{-3} \times 50}{4 + 4 \times 10^{-3}} \approx 0.05 \text{ ms}^{-1}$

Impulse $J = mv = 4 \times .05 = 0.2 \text{ kgms}^{-1}$

9. Choose the correct option :
- (1) True dip is not mathematically related to apparent dip.
 - (2) True dip is less than apparent dip.
 - (3) True dip is always greater than the apparent dip.
 - (4) True dip is always equal to apparent dip.

Official Ans. by NTA (2)

- Sol. If apparent dip circle is at an angle α with true dip circle then

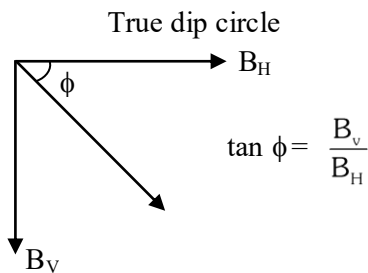

Apparent dip circle

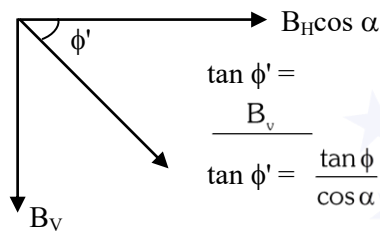

As $\cos \alpha < 1$

Hence true dip (ϕ) is less than apparent dip (ϕ')

10. Consider a situation in which a ring, a solid cylinder and a solid sphere roll down on the same inclined plane without slipping. Assume that they start rolling from rest and having identical diameter.

The **correct** statement for this situation is:-

- (1) The sphere has the greatest and the ring has the least velocity of the centre of mass at the bottom of the inclined plane.
- (2) The ring has the greatest and the cylinder has the least velocity of the centre of mass at the bottom of the inclined plane.
- (3) All of them will have same velocity.
- (4) The cylinder has the greatest and the sphere has the least velocity of the centre of mass at the bottom of the inclined plane.

Official Ans. by NTA (1)

Sol. $a = \frac{g \sin \theta}{1 + \frac{I}{mR^2}}$

$I_{\text{ring}} > I_{\text{solid cylinder}} > I_{\text{solid sphere}}$

$\Rightarrow a_{\text{ring}} < a_{\text{solid cylinder}} < a_{\text{solid sphere}}$

$\Rightarrow v_{\text{ring}} < v_{\text{solid cylinder}} < v_{\text{solid sphere}}$

11. Consider a situation in which reverse biased current of a particular P-N junction increases when it is exposed to a light of wavelength $\leq 621 \text{ nm}$. During this process, enhancement in carrier concentration takes place due to generation of hole-electron pairs. The value of band gap is nearly.

- (1) 2 eV
- (2) 4 eV
- (3) 1 eV
- (4) 0.5 eV

Official Ans. by NTA (1)

Sol. Band gap = $\frac{hc}{\lambda_0}$

λ_0 ; threshold wavelength

Band gap = $\frac{1242 \text{ eV} \cdot \text{nm}}{621 \text{ nm}} = 2 \text{ eV}$

12. A nucleus with mass number 184 initially at rest emits an α -particle. If the Q value of the reaction is 5.5 MeV, calculate the kinetic energy of the α -particle.

- (1) 5.0 MeV
- (2) 5.5 MeV
- (3) 0.12 MeV
- (4) 5.38 MeV

Official Ans. by NTA (4)

Sol.

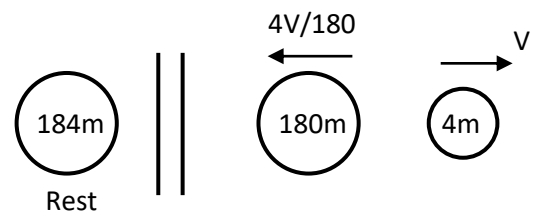

$\frac{1}{2}(4m)v^2 + \frac{1}{2}(180m)\left(\frac{4v}{180}\right)^2 = 5.5 \text{ MeV}$

$\Rightarrow \frac{1}{2}4mv^2 \left[1 + 45 \left(\frac{4}{180} \right)^2 \right] = 5.5 \text{ MeV}$

$\Rightarrow K.E._\alpha = \frac{5.5}{1 + 45 \cdot \left(\frac{4}{180} \right)^2} \text{ MeV}$

$K.E._\alpha = 5.38 \text{ MeV}$

13. An electron of mass m_e and a proton of mass m_p are accelerated through the same potential

difference. The ratio of the de-Broglie wavelength associated with the electron to that with the proton is :-

- (1) $\frac{m_p}{m_e}$ (2) 1 (3) $\sqrt{\frac{m_p}{m_e}}$ (4) $\frac{m_e}{m_p}$

Official Ans. by NTA (3)

Sol. $KE = e\Delta V$

$$\lambda_e = \frac{h}{\sqrt{2m_e(e\Delta V)}}$$

$$\lambda_p = \frac{h}{\sqrt{2m_p(e\Delta V)}} \Rightarrow \frac{\lambda_e}{\lambda_p} = \sqrt{\frac{m_p}{m_e}}$$

14. Match List-I with List-II :

| | List-I | | List-II |
|-----|---------------------------------|-------|-------------------------------------|
| (a) | $\omega L > \frac{1}{\omega C}$ | (i) | Current is in phase with emf |
| (b) | $\omega L = \frac{1}{\omega C}$ | (ii) | Current lags behind the applied emf |
| (c) | $\omega L < \frac{1}{\omega C}$ | (iii) | Maximum current occurs |
| (d) | Resonant frequency | (iv) | Current leads the emf |

Choose the **correct** answer from the options given below :

- (1) (a) – (ii) ; (b) – (i) ; (c) – (iv) ; (d) – (iii)
 (2) (a) – (ii) ; (b) – (i) ; (c) – (iii) ; (d) – (iv)
 (3) (a) – (iii) ; (b) – (i) ; (c) – (iv) ; (d) – (ii)
 (4) (a) – (iv) ; (b) – (iii) ; (c) – (ii) ; (d) – (i)

Official Ans. by NTA (1)

Sol. (a) For $x_L > x_C$, voltage leads the current

(ii)

(b) For $x_L = x_C$, voltage & current are in same phase

(i)

(c) For $x_L < x_C$, current leads the voltage

(iv)

(d) For resonant frequency $x_L = x_C$, current is maximum

(iii)

15. What should be the height of transmitting antenna and the population covered if the television

telecast is to cover a radius of 150 km ? The average population density around the tower is 2000/km² and the value of $R_e = 6.5 \times 10^6$ m.

(1) Height = 1731 m

Population Covered = 1413×10^5

(2) Height = 1241 m

Population Covered = 7×10^5

(3) Height = 1600 m

Population Covered = 2×10^5

(4) Height = 1800 m

Population Covered = 1413×10^8

Official Ans. by NTA (1)

Sol. Radius covered $r = \sqrt{2RH_T}$

$$150 \text{ km} = \sqrt{2 \times (6.5 \times 10^6 \text{ m}) H_T}$$

$$(150 \text{ km} \times 10^3)^2 = 2 \times 6.5 \times 10^6 H_T$$

$$H_T = 1731 \text{ m}$$

$$\text{Population covered} = (\pi r^2)(2000/\text{km}^2)$$

$$= 3.14 \times (150)^2 \times 2000 = 1413 \times 10^5$$

16. What will be the average value of energy for a monoatomic gas in thermal equilibrium at temperature T ?

- (1) $\frac{2}{3}k_B T$ (2) $k_B T$ (3) $\frac{3}{2}k_B T$ (4) $\frac{1}{2}k_B T$

Official Ans. by NTA (3)

Sol. As per Equi-partition law :

Each degree of freedom contributes

$$\frac{1}{2}k_B T \text{ Average Energy}$$

In monoatomic gas D.O.F. = 3

$$\Rightarrow \text{Average energy} = 3 \times \frac{1}{2}k_B T = \frac{3}{2}k_B T$$

17. Intensity of sunlight is observed as 0.092 Wm⁻² at a point in free space. What will be the peak value of magnetic field at that point ?

$$(\epsilon_0 = 8.85 \times 10^{-12} \text{C}^2\text{N}^{-1}\text{m}^{-2})$$

(1) 2.77×10^{-8} T

(2) 1.96×10^{-8} T

(3) 8.31 T

(4) 5.88 T

Official Ans. by NTA (1)

Sol. $I_{avg} = \frac{B_0^2 C}{2\mu_0}$ & $\frac{1}{\mu_0} = \epsilon_0 C^2$

$$I = \frac{B_0^2}{2} \epsilon_0 C^3$$

$$B_0 = \sqrt{\frac{2I}{\epsilon_0 C^3}}$$

$$B_0 = 2.77 \times 10^{-8} \text{ T}$$

18. The motion of a mass on a spring, with spring constant K is as shown in figure.

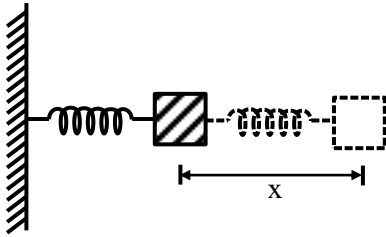

The equation of motion is given by $x(t) = A \sin \omega t +$

$$B \cos \omega t \text{ with } \omega = \sqrt{\frac{K}{m}}$$

Suppose that at time $t = 0$, the position of mass is $x(0)$ and velocity $v(0)$, then its displacement can also be represented as $x(t) = C \cos(\omega t - \phi)$, where C and ϕ are :

$$(1) C = \sqrt{\frac{2v(0)^2}{\omega^2} + x(0)^2}, \phi = \tan^{-1} \left(\frac{v(0)}{x(0)\omega} \right)$$

$$(2) C = \sqrt{\frac{2v(0)^2}{\omega^2} + x(0)^2}, \phi = \tan^{-1} \left(\frac{x(0)\omega}{2v(0)} \right)$$

$$(3) C = \sqrt{\frac{v(0)^2}{\omega^2} + x(0)^2}, \phi = \tan^{-1} \left(\frac{x(0)\omega}{v(0)} \right)$$

$$(4) C = \sqrt{\frac{v(0)^2}{\omega^2} + x(0)^2}, \phi = \tan^{-1} \left(\frac{v(0)}{x(0)\omega} \right)$$

Official Ans. by NTA (4)

Sol. $x = A \sin \omega t + B \cos \omega t$

$$v = \frac{dx}{dt} = A\omega \cos \omega t - B\omega \sin \omega t$$

At $t = 0$, $x(0) = B$

$$v(0) = A\omega$$

$$x = A \sin \omega t + B \sin(\omega t + 90^\circ)$$

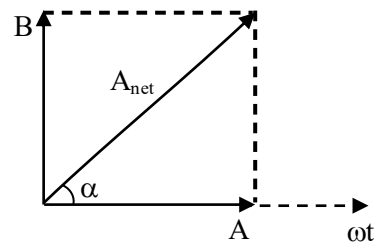

$$A_{net} = \sqrt{A^2 + B^2}$$

$$\tan \alpha = \frac{B}{A} \Rightarrow \cot \alpha = \frac{A}{B}$$

$$\Rightarrow x = \sqrt{A^2 + B^2} \sin(\omega t + \alpha)$$

$$\Rightarrow x = \sqrt{A^2 + B^2} \cos(\omega t - (90 - \alpha))$$

$$x = C \cos(\omega t - \phi)$$

$$\Rightarrow C = \sqrt{A^2 + B^2}$$

$$C = \sqrt{\frac{[v(0)]^2}{\omega^2} + [x(0)]^2}$$

$$\phi = 90 - \alpha$$

$$\tan \alpha = \cot \alpha = \frac{A}{B}$$

$$\Rightarrow \tan \phi = \frac{v(0)}{x(0)\omega}$$

$$\phi = \tan^{-1} \left(\frac{v(0)}{x(0)\omega} \right)$$

19. An electric dipole is placed on x-axis in proximity to a line charge of linear charge density $3.0 \times 10^{-6} \text{ C/m}$. Line charge is placed on z-axis and positive and negative charge of dipole is at a distance of 10 mm and 12 mm from the origin respectively. If total force of 4 N is exerted on the dipole, find out the amount of positive or negative charge of the dipole.

(1) 815.1 nC

(2) 8.8 μC

(3) 0.485 mC

(4) 4.44 μC

Official Ans. by NTA (4)

Sol.

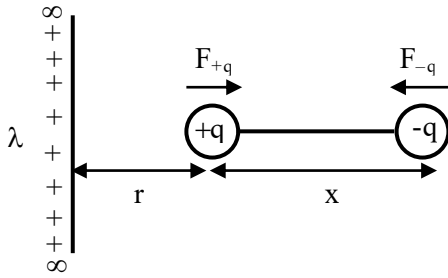

$$r = 10 \text{ mm}, x = 2 \text{ mm}$$

$$|\vec{F}_q| = \frac{2k\lambda}{r} \cdot q$$

$$|\vec{F}_{-q}| = \frac{2k\lambda}{r+x} \cdot q$$

$$\Rightarrow |\vec{F}_{\text{net}}| = \frac{2k\lambda q}{r} - \frac{2k\lambda q}{r+x}$$

$$|\vec{F}_{\text{net}}| = \frac{2k\lambda q \cdot x}{r(r+x)}$$

$$4 = \frac{2 \times 9 \times 10^9 \times 3 \times 10^{-6} \times q \times 2 \text{ mm}}{10 \text{ mm} \cdot 12 \text{ mm}}$$

$$\Rightarrow q = 4.44 \text{ } \mu\text{C}$$

20. A body is projected vertically upwards from the surface of earth with a velocity sufficient enough to carry it to infinity. The time taken by it to reach height h is _____ S.

$$(1) \sqrt{\frac{R_e}{2g}} \left[\left(1 + \frac{h}{R_e} \right)^{3/2} - 1 \right]$$

$$(2) \sqrt{\frac{2R_e}{g}} \left[\left(1 + \frac{h}{R_e} \right)^{3/2} - 1 \right]$$

$$(3) \frac{1}{3} \sqrt{\frac{R_e}{2g}} \left[\left(1 + \frac{h}{R_e} \right)^{3/2} - 1 \right]$$

$$(4) \frac{1}{3} \sqrt{\frac{2R_e}{g}} \left[\left(1 + \frac{h}{R_e} \right)^{3/2} - 1 \right]$$

Official Ans. by NTA (4)

Sol.

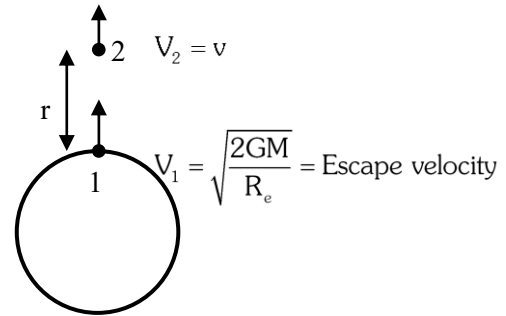

Applying energy conservation from (1) to (2)

$$\frac{1}{2} m \left(\frac{2GM}{R_e} \right) - \frac{GMm}{R_e} = \frac{1}{2} m v^2 - \frac{GMm}{R+r}$$

$$\Rightarrow \frac{1}{2} m v^2 = \frac{GMm}{R+r}$$

$$\Rightarrow v = \sqrt{\frac{2GM}{R+r}} = \frac{dr}{dt}$$

$$\Rightarrow \sqrt{2GM} \int_0^t dt = \int_{R_e}^{R_e+h} (\sqrt{R+r}) dr$$

$$\sqrt{2GM} \cdot t = \frac{2}{3} \left[(R+r)^{3/2} \right]_{R_e}^{R_e+h}$$

$$t = \frac{2}{3} \sqrt{\frac{R_e^3}{2GM}} \left[\left(1 + \frac{h}{R_e} \right)^{3/2} - 1 \right]$$

$$\frac{GM}{R_e^2} = g$$

$$t = \frac{1}{3} \sqrt{\frac{2R_e}{g}} \left[\left(1 + \frac{h}{R_e} \right)^{3/2} - 1 \right]$$

SECTION-B

1. In a given circuit diagram, a 5 V zener diode along with a series resistance is connected across a 50 V power supply. The minimum value of the resistance required, if the maximum zener current is 90 mA will be _____ Ω .

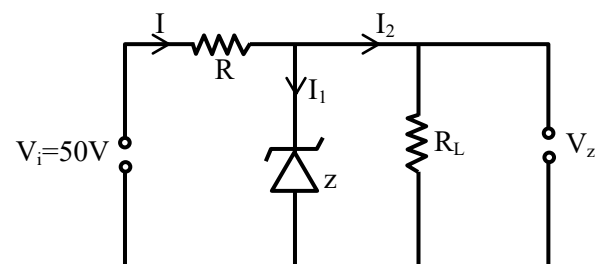

Official Ans. by NTA (500)

Sol.

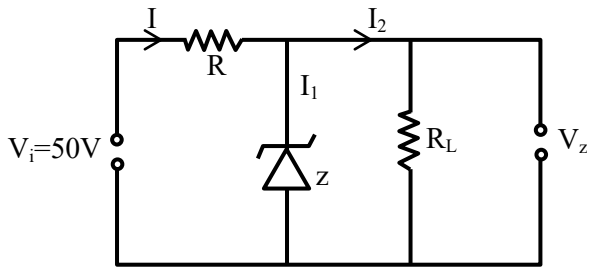

Voltage across $R_L = 5V$

$$\Rightarrow i_2 = \frac{5}{R_L}$$

Also voltage across $R = 50 - 5 = 45$ volt

$$\text{By } v = iR \Rightarrow R = \frac{v}{i} = \frac{45}{i_1 + i_2}$$

$$R = \frac{45}{90\text{mA} + \frac{5}{R_L}}$$

Current in zener diode is maximum when $R_L \rightarrow \infty$
($i_2 \rightarrow 0$ and $i_1 = i$)

$$\text{So } R = \frac{45}{90\text{mA}} = 500\Omega$$

2. The position of the centre of mass of a uniform semi-circular wire of radius 'R' placed in x-y plane with its centre at the origin and the line joining its ends as x-axis is given by $\left(0, \frac{xR}{\pi}\right)$.

Then, the value of |x| is _____.

Official Ans. by NTA (2)

- Sol. COM of semi-circular ring is at $\frac{2R}{\pi}$

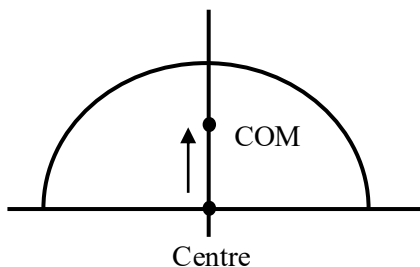

Distance from centre $\Rightarrow x = \frac{2R}{\pi}$

3. In an electric circuit, a cell of certain emf provides a potential difference of 1.25 V across a load resistance of 5Ω . However, it provides a potential difference of 1 V across a load resistance of 2Ω .

The emf of the cell is given by $\frac{x}{10}$ V. Then the value of x is _____.

Official Ans. by NTA (15)

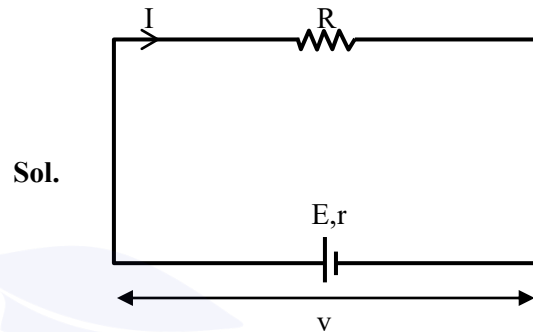

Sol.

$$\text{Terminal voltage } v = iR = \frac{ER}{R+r}$$

$$1^{\text{st}} \rightarrow 1.25 = \frac{E(5)}{5+r} \dots(i)$$

$$2^{\text{nd}} \rightarrow 1 = \frac{E(2)}{2+r} \dots(ii)$$

By (i) and (ii)

$$r = 1\Omega, E = \frac{3}{2}V = \frac{15}{10}\text{ volt}$$

$$\Rightarrow x = 15$$

4. The total charge enclosed in an incremental volume of $2 \times 10^{-9} \text{ m}^3$ located at the origin is _____ nC, if electric flux density of its field is found as $D = e^{-x} \sin y \hat{i} - e^{-x} \cos y \hat{j} + 2z \hat{k} \text{ C/m}^2$.

Official Ans. by NTA (4)

Sol. Electric flux density

$$(\vec{D}) = \frac{\text{charge}}{\text{Area}} \times \vec{r} = \frac{Q}{4\pi r^2} \vec{r} = \epsilon_0 \left(\frac{Q}{4\pi \epsilon_0 r^2} \vec{r} \right)$$

$$\Rightarrow \vec{E} = \frac{\vec{D}}{\epsilon_0} = \frac{e^{-x} \sin y \hat{i} - e^{-x} \cos y \hat{j} + 2z \hat{k}}{\epsilon_0}$$

Also by Gauss's law

$$\frac{\rho}{\epsilon_0} = \left(\frac{\partial}{\partial x} \tilde{i} + \frac{\partial}{\partial y} \tilde{j} + \frac{\partial}{\partial z} \tilde{k} \right) \cdot \vec{E} = \left(\frac{\partial}{\partial x} \tilde{i} + \frac{\partial}{\partial y} \tilde{j} + \frac{\partial}{\partial z} \tilde{k} \right) \cdot \frac{\vec{D}}{\epsilon_0}$$

$$\Rightarrow \rho = \frac{\partial}{\partial x} (e^{-x} \sin y) + \frac{\partial}{\partial y} (-e^{-x} \cos y) + \frac{\partial}{\partial z} (2z)$$

$$\rho = -e^{-x} \sin y + e^{-x} \sin y + 2$$

At origin $\rho = -e^{-0} \sin 0 + e^{-0} \sin 0 + 2$

$$\rho = 2C / m^3$$

Charge = $\rho \times \text{volume} = 2 \times 2 \times 10^{-9} = 4 \times 10^{-9} = 4nC$

5. Three particles P, Q and R are moving along the vectors $\vec{A} = \hat{i} + \hat{j}$, $\vec{B} = \hat{j} + \hat{k}$ and $\vec{C} = -\hat{i} + \hat{j}$ respectively. They strike on a point and start to move in different directions. Now particle P is moving normal to the plane which contains vector \vec{A} and \vec{B} . Similarly particle Q is moving normal to the plane which contains vector \vec{A} and \vec{C} . The angle between the direction of motion of P and Q is $\cos^{-1} \left(\frac{1}{\sqrt{x}} \right)$. Then the value of x is _____.

Official Ans. by NTA (3)

Sol. Direction of P $\vec{v}_1 = \pm \frac{\vec{A} \times \vec{B}}{|\vec{A} \times \vec{B}|} = \pm \frac{\tilde{i} - \tilde{j} + \tilde{k}}{\sqrt{3}}$

Direction of Q $\vec{v}_2 = \pm \frac{\vec{A} \times \vec{C}}{|\vec{A} \times \vec{C}|} = \pm \frac{2\tilde{k}}{2} = \pm \tilde{k}$

Angle between \vec{v}_1 and \vec{v}_2

$$\frac{\vec{v}_1 \cdot \vec{v}_2}{|\vec{v}_1| |\vec{v}_2|} = \frac{\pm 1 / \sqrt{3}}{(1)(1)} = \pm \frac{1}{\sqrt{3}}$$

$$\Rightarrow x = 3$$

6. The centre of a wheel rolling on a plane surface moves with a speed v_0 . A particle on the rim of the wheel at the same level as the centre will be moving at a speed $\sqrt{x} v_0$. Then the value of x is _____.

Official Ans. by NTA (2)

Sol.

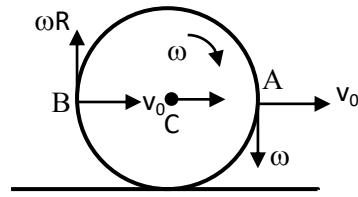

For no slipping $v_0 = \omega R$

Now $v_A = v_B = \sqrt{v_0^2 + (\omega R)^2}$

$$= \sqrt{2} v_0$$

$$\Rightarrow x = 2$$

7. A ray of light passing through a prism ($\mu = \sqrt{3}$) suffers minimum deviation. It is found that the angle of incidence is double the angle of refraction within the prism. Then, the angle of prism is _____ (in degrees)

Official Ans. by NTA (60)

Sol. At minimum deviation $r_1 = r_2 = \frac{A}{2}$

Also given $i = 2r_1 = A$

Now $1 \cdot \sin i = \sqrt{3} \sin r_1$

$$1 \sin A = \sqrt{3} \sin \frac{A}{2}$$

$$\Rightarrow 2 \sin \frac{A}{2} \cos \frac{A}{2} = \sqrt{3} \sin \frac{A}{2}$$

$$\Rightarrow \cos \frac{A}{2} = \frac{\sqrt{3}}{2} \Rightarrow \frac{A}{2} = 30^\circ$$

$$\Rightarrow A = 60^\circ$$

8. The area of cross-section of a railway track is 0.01 m^2 . The temperature variation is 10°C . Coefficient of linear expansion of material of track is $10^{-5}/^\circ\text{C}$. The energy stored per meter in the track is _____ J/m. (Young's modulus of material of track is 10^{11} Nm^{-2})

Official Ans. by NTA (5)

Sol. Elastic energy = $\frac{Y}{2}(\text{strain})^2 \times \text{Area} \times \text{length}$

\Rightarrow Elastic energy per unit length = $\frac{Y}{2}(\text{strain})^2 \times \text{Area}$

$$\left(\text{strain} = \frac{\Delta \ell}{\ell} = \alpha \Delta T = 10^{-5} \times 10 = 10^{-4} \right)$$

$$= \frac{10^{11}}{2} \times (10^{-4})^2 \times 10^{-2} = 5 \text{ J/m}$$

9. Three students S_1 , S_2 and S_3 perform an experiment for determining the acceleration due to gravity (g) using a simple pendulum. They use different lengths of pendulum and record time for different number of oscillations. The observations are as shown in the table.

| Student No. | Length of pendulum (cm) | No. of oscillations (n) | Total time for n oscillations | Time period (s) |
|-------------|-------------------------|-------------------------|-------------------------------|-----------------|
| 1. | 64.0 | 8 | 128.0 | 16.0 |
| 2. | 64.0 | 4 | 64.0 | 16.0 |
| 3. | 20.0 | 4 | 36.0 | 9.0 |

(Least count of length = 0.1 m

least count for time = 0.1 s)

If E_1 , E_2 and E_3 are the percentage errors in ' g ' for students 1, 2 and 3 respectively, then the minimum percentage error is obtained by student no. _____.

Official Ans. by NTA (1)

Sol. $T = 2\pi \sqrt{\frac{\ell}{g}} \Rightarrow g = \frac{4\pi^2 \ell}{T^2}$

$$\frac{\Delta g}{g} = \frac{\Delta \ell}{\ell} + \frac{2\Delta T}{T}$$

$$\Delta T = \frac{\text{least count of time } (\Delta T_0)}{\text{number of oscillations}(n)}$$

$$\frac{\Delta g}{g} = \frac{\Delta \ell}{\ell} + \frac{2\Delta T_0}{nT}$$

As $\Delta \ell$ and ΔT_0 are same for all observations so

$\frac{\Delta g}{g}$ is minimum for highest value of ℓ , n and T

\Rightarrow Minimum percentage error in g is for student number-1

10. In 5 minutes, a body cools from 75°C to 65°C at room temperature of 25°C . The temperature of body at the end of next 5 minutes is _____ $^\circ\text{C}$.

Official Ans. by NTA (57)

Sol. By newton's law of cooling (with approximation)

$$\frac{\Delta T}{\Delta t} = -C(T_{\text{avg}} - T_s)$$

$$1^{\text{st}} \frac{-10^\circ\text{C}}{5 \text{ min}} = -C(70^\circ\text{C} - 25^\circ\text{C})$$

$$\Rightarrow C = \frac{2}{45} \text{ min}^{-1}$$

$$2^{\text{nd}} \frac{T - 65}{5 \text{ min}} = -C\left(\frac{T + 65}{2} - 25\right) = -\left(\frac{2}{45}\right)\left(\frac{T + 15}{2}\right)$$

$$\Rightarrow 9(T - 65) = -(T + 15)$$

$$\Rightarrow 10T = 570$$

$$\Rightarrow T = 57^\circ\text{C}$$

Alternate Solution :

Newton's law of cooling (without approximation)

$$T_p - T_s = (T_i - T_s)e^{-Ct}$$

$$1^{\text{st}} \quad 65 - 25 = (75 - 25)e^{-5C} \Rightarrow e^{-5C} = \frac{4}{5}$$

$$2^{\text{nd}} \quad T - 25 = (65 - 25)e^{-5C} = 40 \times \frac{4}{5} = 32$$

$$T = 57^\circ\text{C}$$