

FINAL JEE–MAIN EXAMINATION – JULY, 2022

(Held On Wednesday 27th July, 2022)

TIME : 3 : 00 PM to 6 : 00 PM

SECTION-A

1. An expression of energy density is given by

$$u = \frac{\alpha}{\beta} \sin\left(\frac{\alpha x}{kt}\right), \text{ where } \alpha, \beta \text{ are constants, } x \text{ is}$$

displacement, k is Boltzmann constant and t is the temperature. The dimensions of β will be :

(A) $[ML^2T^{-2}\theta^{-1}]$ (B) $[M^0L^2T^{-2}]$

(C) $[M^0L^0T^0]$ (D) $[M^0L^2T^0]$

Official Ans. by NTA (D)

Ans. (D)

Sol. $\frac{\alpha[L]}{[ML^2T^{-2}]} = [M^0L^0T^0]$

$$\alpha = [ML^1T^{-2}]$$

$$\frac{\alpha}{\beta} = \frac{[ML^2T^{-2}]}{[L^3]} \Rightarrow \beta = \frac{[ML^1T^{-2}][L^3]}{ML^2T^{-2}}$$

2. A body of mass 10 kg is projected at an angle of 45° with the horizontal. The trajectory of the body is observed to pass through a point (20, 10). If T is the time of flight, then its momentum vector, at time $t = \frac{T}{\sqrt{2}}$, is _____

[Take $g = 10 \text{ m/s}^2$]

(A) $100\hat{i} + (100\sqrt{2} - 200)\hat{j}$

(B) $100\sqrt{2}\hat{i} + (100 - 200\sqrt{2})\hat{j}$

(C) $100\hat{i} + (100 - 200\sqrt{2})\hat{j}$

(D) $100\sqrt{2}\hat{i} + (100\sqrt{2} - 200)\hat{j}$

Official Ans. by NTA (D)

Ans. (D)

Sol. $y = x - \frac{10x^2}{2u^2\left(\frac{1}{2}\right)} \Rightarrow 10 = 20 - \frac{(10)(100)}{u^2}$

$$u = 20$$

$$T = \frac{(2)(20)}{\sqrt{2}(10)} = 2\sqrt{2}$$

$$\vec{v} = 10\sqrt{2}\hat{i} + (10\sqrt{2} - 10(2))\hat{j}$$

$$\text{Momentum } \vec{p} = M\vec{v} = 100\sqrt{2}\hat{i} + (100\sqrt{2} - 200)\hat{j}$$

3. A block of mass M slides down on a rough inclined plane with constant velocity. The angle made by the incline plane with horizontal is θ . The magnitude of the contact force will be :

(A) Mg

(B) $Mg \cos \theta$

(C) $\sqrt{Mg \sin \theta + Mg \cos \theta}$

(D) $Mg \sin \theta \sqrt{1 + \mu}$

Official Ans. by NTA (A)

Ans. (A)

Sol.

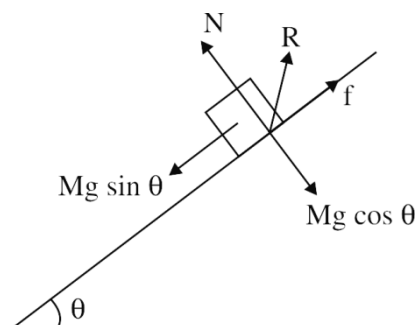

$$N = Mg \cos \theta$$

$$f = Mg \sin \theta$$

$$R = \sqrt{N^2 + f^2}$$

$$R = Mg$$

4. A block 'A' takes 2 s to slide down a frictionless incline of 30° and length ' l ', kept inside a lift going up with uniform velocity ' v '. If the incline is changed to 45° , the time taken by the block, to slide down the incline, will be approximately:
 (A) 2.66 s (B) 0.83 s
 (C) 1.68 s (D) 0.70 s

Official Ans. by NTA (C)

_____ Ans. (C)

Sol.

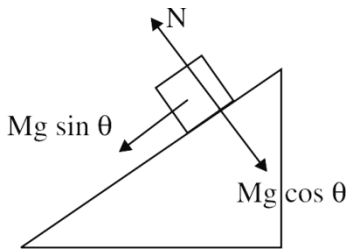

$$a = g \sin \theta$$

$$l = \frac{1}{2} g \sin 30^\circ (2)^2 \quad \dots(1)$$

$$l = \frac{1}{2} g \sin 45^\circ t^2 \quad \dots(2)$$

$$\left(\frac{1}{2}\right)(4) = \frac{1}{\sqrt{2}} t^2 \Rightarrow t = \sqrt{2\sqrt{2}} \approx 1.68$$

5. The velocity of the bullet becomes one third after it penetrates 4 cm in a wooden block. Assuming that bullet is facing a constant resistance during its motion in the block. The bullet stops completely after travelling at $(4 + x)$ cm inside the block. The value of x is:
 (A) 2.0 (B) 1.0
 (C) 0.5 (D) 1.5

Official Ans. by NTA (C)

_____ Ans. (C)

Sol.

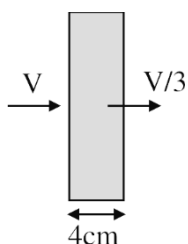

$$\left(\frac{V}{3}\right)^2 = V^2 - 2a(4) \Rightarrow a = \frac{8V^2}{9(8)} = \frac{V^2}{9}$$

$$0 = V^2 - 2a(4 + x)$$

$$\Rightarrow V^2 = 2\left(\frac{V^2}{9}\right)(4 + x)$$

$$4.5 = 4 + x$$

$$x = 0.5$$

6. A body of mass m is projected with velocity λv_e in vertically upward direction from the surface of the earth into space. It is given that v_e is escape velocity and $\lambda < 1$. If air resistance is considered to be negligible, then the maximum height from the centre of earth, to which the body can go, will be (R : radius of earth)
 (A) $\frac{R}{1 + \lambda^2}$ (B) $\frac{R}{1 - \lambda^2}$
 (C) $\frac{R}{1 - \lambda}$ (D) $\frac{\lambda^2 R}{1 - \lambda^2}$

Official Ans. by NTA (B)

_____ Ans. (B)

Sol.

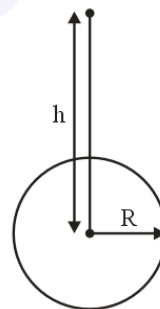

$$-\frac{GMm}{R} + \frac{1}{2} m \lambda^2 v_e^2 = -\frac{GMm}{h}$$

$$-\frac{GMm}{R} + \frac{1}{2} \lambda^2 \frac{2GMm}{R} = -\frac{GMm}{h}$$

$$\frac{\lambda^2}{R} - \frac{1}{R} = \frac{-1}{h}$$

$$\frac{1}{h} = \frac{1 - \lambda^2}{R}$$

$$h = \frac{R}{1 - \lambda^2}$$

7. A steel wire of length 3.2 m ($Y_s = 2.0 \times 10^{11} \text{ Nm}^{-2}$) and a copper wire of length 4.4 m ($Y_c = 1.1 \times 10^{11} \text{ Nm}^{-2}$), both of radius 1.4 mm are connected end to end. When stretched by a load, the net elongation is found to be 1.4 mm. The load applied, in Newton, will be: (Given $\pi = \frac{22}{7}$)
 (A) 360 (B) 180 (C) 1080 (D) 154

Official Ans. by NTA (D)

Ans. (D)

Sol.

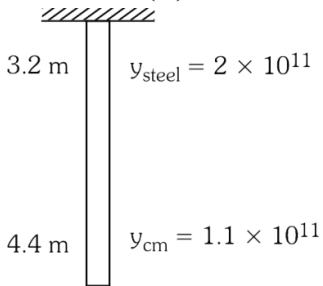

$$\Delta l_1 + \Delta l_2 = \Delta l$$

$$\frac{F l_1}{A_1 Y_1} + \frac{F l_2}{A_2 Y_2} = \Delta l$$

$$F = \frac{\Delta l}{\frac{l_1}{A_1 Y_1} + \frac{l_2}{A_2 Y_2}} = 1.54 \times 10^2 = 154$$

8. In 1st case, Carnot engine operates between temperatures 300 K and 100 K. In 2nd case, as shown in the figure, a combination of two engines is used. The efficiency of this combination (in 2nd case) will be :

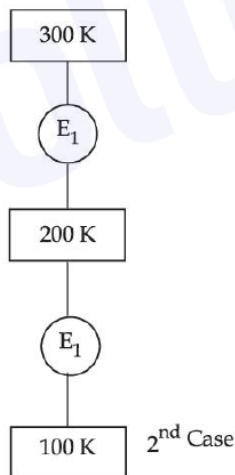

- (A) same as the 1st case
 (B) always greater than the 1st case
 (C) always less than the 1st case
 (D) may increase or decrease with respect to the 1st case

Official Ans. by NTA (A)

Ans. (A)

Sol. First case : $\eta = 1 - \frac{100}{300} = \frac{2}{3}$

Second case : $\eta_{\text{net}} = \eta_1 + \eta_2 - \eta_1 \eta_2$

$$\eta_1 = 1 - \frac{200}{300} = \frac{1}{3}$$

$$\eta_2 = 1 - \frac{100}{200} = \frac{1}{2}$$

$$\eta_{\text{net}} = \frac{1}{3} + \frac{1}{2} - \frac{1}{6} = \frac{2}{3}$$

η (first case) = η (second case)

9. Which statements are correct about degrees of freedom?
 A. A molecule with n degrees of freedom has n² different ways of storing energy.
 B. Each degree of freedom is associated with $\frac{1}{2}RT$ average energy per mole.
 C. A monoatomic gas molecule has 1 rotational degree of freedom where as diatomic molecule has 2 rotational degrees of freedom
 D. CH₄ has a total to 6 degrees of freedom
 Choose the correct answer from the option given below:
 (A) B and C only (B) B and D only
 (C) A and B only (D) C and D only

Official Ans. by NTA (B)

Ans. (B)

Sol. Methane molecule is tetrahedron
 Degree of freedom due to rotation = 3
 Degree of freedom due to translation = 3

10. A charge of 4 μC is to be divided into two. The distance between the two divided charges is constant. The magnitude of the divided charges so that the force between them is maximum, will be:
 (A) 1 μC and 3 μC (B) 2 μC and 2 μC
 (C) 0 and 4 μC (D) 1.5 μC and 2.5 μC

Official Ans. by NTA (B)

Ans. (B)

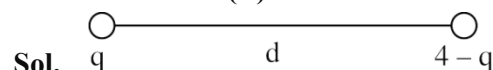

Sol.

$$F = \frac{Kq(4-q)}{d^2}$$

$$\frac{dF}{dq} = \frac{K}{d^2} [4 - 2q] = 0$$

$$q = 2$$

11. A. The drift velocity of electrons decreases with the increase in the temperature of conductor.
 B. The drift velocity is inversely proportional to the area of cross-section of given conductor.
 C. The drift velocity does not depend on the applied potential difference to the conductor.
 D. The drift velocity of electron is inversely proportional to the length of the conductor.
 E. The drift velocity increases with the increase in the temperature of conductor.

Choose the correct answer from the options given below:

- (A) A and B only (B) A and D only
 (C) B and E only (D) B and C only

Official Ans. by NTA (B)

Ans. (B)

Sol. Drift velocity = $\left(\frac{e\tau}{m}\right)E$

$$v_d = \left(\frac{e\tau}{m}\right)\left(\frac{\Delta V}{\ell}\right)$$

ΔV = Potential difference applied across the wire

As temperature increases, relaxation time decreases, hence V_d decreases.

As per formula, $V_d \propto \frac{1}{\ell}$

$v_d = \frac{I}{neA}$, as it is not mentioned that current is at steady state neither it is mentioned that n is constant for given conductor. So it can't be said that v_d is inversely proportional to A .

$$I = neAv_d = \frac{V}{R} = \frac{V}{\rho\ell}A$$

$$v_d = \frac{V}{\rho\ell ne} \quad \left(E = \frac{V}{\ell}\right)$$

$$v_d = \frac{eE\tau}{m}$$

τ decrease with temperature increase.

First and fourth statements are correct.

12. A compass needle of oscillation magnetometer oscillates 20 times per minute at a place P of dip 30° . The number of oscillations per minute become 10 at another place Q of 60° dip. The ratio of the total magnetic field at the two places ($B_Q : B_P$) is:

- (A) $\sqrt{3} : 4$ (B) $4 : \sqrt{3}$
 (C) $\sqrt{3} : 2$ (D) $2 : \sqrt{3}$

Official Ans. by NTA (A)

Ans. (A)

Sol. $T = 2\pi \sqrt{\frac{I}{B_H M}}$

$$T_1 = 3 \text{ sec} = 2\pi \sqrt{\frac{I}{(B_P \cos 30^\circ)M}}$$

$$T_2 = 6 \text{ sec} = 2\pi \sqrt{\frac{I}{(B_Q \cos 60^\circ)M}}$$

$$\frac{3}{6} = \frac{1}{\left(\frac{B_P \sqrt{3}}{2}\right)} \times (B_Q / 2)$$

$$\frac{3}{6} = \sqrt{\left(\frac{B_Q}{\sqrt{3}B_P}\right)}$$

$$\frac{\sqrt{3}}{4} = \frac{B_Q}{B_P}$$

$$B_Q : B_P = \sqrt{3} : 4$$

13. A cyclotron is used to accelerate protons. If the operating magnetic field is 1.0 T and the radius of the cyclotron 'dees' is 60 cm, the kinetic energy of the accelerated protons in MeV will be :

[use $m_p = 1.6 \times 10^{-27}$ kg, $e = 1.6 \times 10^{-19}$ C]

- (A) 12 (B) 18
 (C) 16 (D) 32

Official Ans. by NTA (B)

Ans. (B)

Sol. Kinetic energy of electron in cyclotron

$$= \left[\frac{q^2 B^2 r_0^2}{2m} \right]$$

$$= 18 \text{ MeV}$$

14. A series LCR circuit has $L = 0.01 \text{ H}$, $R = 10 \ \Omega$ and $C = 1 \ \mu\text{F}$ and it is connected to ac voltage of amplitude (V_m) 50 V . At frequency 60% lower than resonant frequency, the amplitude of current will be approximately :

- (A) 466 mA (B) 312 mA
(C) 238 mA (D) 196 mA

Official Ans. by NTA (C)

Ans. (C)

Sol. Resonant frequency, $\omega_0 = \frac{1}{\sqrt{LC}} = 10^4 \text{ rad/sec}$

$$\omega' = .4 \times 10^4 = 4000 \text{ rad/sec}$$

$$i_0 = \frac{V_0}{\sqrt{R^2 + (X'_C - X'_L)^2}} = 238 \text{ mA}$$

15. Identify the correct statements from the following descriptions of various properties of electromagnetic waves.

- A. In a plane electromagnetic wave electric field and magnetic field must be perpendicular to each other and direction of propagation of wave should be along electric field or magnetic field.
B. The energy in electromagnetic wave is divided equally between electric and magnetic fields.
C. Both electric field and magnetic field are parallel to each other and perpendicular to the direction of propagation of wave.
D. The electric field, magnetic field and direction of propagation of wave must be perpendicular to each other.
E. The ratio of amplitude of magnetic field to the amplitude of electric field is equal to speed of light.

Choose the most appropriate answer from the options given below:

- (A) D only
(B) B and D only
(C) B, C and E only
(D) A, B and E only

Official Ans. by NTA (B)

Ans. (B)

Sol. Second and fourth statements are correct.

16. Two coherent sources of light interfere. The intensity ratio of two sources is 1 : 4. For this interference pattern if the value of $\frac{I_{\max} + I_{\min}}{I_{\max} - I_{\min}}$ is

equal to $\frac{2\alpha + 1}{\beta + 3}$, then $\frac{\alpha}{\beta}$ will be :

- (A) 1.5 (B) 2 (C) 0.5 (D) 1

Official Ans. by NTA (B)

Ans. (B)

Sol. $\frac{I_1}{I_2} = \frac{1}{4}$

$$I_2 = 4I_1$$

$$I_{\max} = I_1 + 4I_1 + 2\sqrt{I_1 \cdot 4I_1} = 9I_1$$

$$I_{\min} = I_1 + 4I_1 - 2\sqrt{I_1 \cdot 4I_1} = I_1$$

$$\therefore \frac{9I_1 + I_1}{9I_1 - I_1} = \frac{10}{8} = \frac{5}{4} = \frac{2\alpha + 1}{\beta + 1}$$

$$\alpha = 2 \quad \beta = 1$$

$$\therefore \frac{\alpha}{\beta} = \frac{2}{1} = 2$$

17. With reference to the observations in photo-electric effect, identify the correct statements from below:

- A. The square of maximum velocity of photoelectrons varies linearly with frequency of incident light.
B. The value of saturation current increases on moving the source of light away from the metal surface.
C. The maximum kinetic energy of photo-electrons decreases on decreasing the power of LED (light emitting diode) source of light.
D. The immediate emission of photo-electrons out of metal surface can not be explained by particle nature of light/electromagnetic waves.
E. Existence of threshold wavelength can not be explained by wave nature of light/electromagnetic waves.

Choose the correct answer from the options given below:

- (A) A and B only (B) A and E only
(C) C and E only (D) D and E only

Official Ans. by NTA (B)

Ans. (B)

Sol. $\frac{1}{2} mV_{\max}^2 = hf - \phi$

Photoelectric effect can be explained by particle nature of light. Threshold λ is max wavelength at which emission takes place.

18. The activity of a radioactive material is 6.4×10^{-4} curie. Its half life is 5 days. The activity will become 5×10^{-6} curie after :

- (A) 7 days (B) 15 days
(C) 25 days (D) 35 days

Official Ans. by NTA (D)

Ans. (D)

Sol. $A_0 = 6.4 \times 10^{-4}$ Curie

$$T_{1/2} = 5 \text{ days} = \frac{\ln 2}{\lambda}$$

$$A = A_0 e^{-\lambda t}$$

$$5 \times 10^{-6} = 6.4 \times 10^{-4} e^{-\lambda t}$$

$$\frac{5}{6.4} \times 10^{-2} = e^{-\lambda t}$$

$$7.8 \times 10^{-3} = e^{-\lambda t}$$

$$\log(7.8 \times 10^{-3}) = -\lambda t \ln e$$

$$\ln(7.8 \times 10^{-3}) = -\frac{\lambda n 2}{5} \cdot t$$

$$\therefore \frac{5 \times 4.853}{0.693} = t = 35 \text{ days}$$

19. For a constant collector-emitter voltage of 8V, the collector current of a transistor reached to the value of 6 mA from 4 mA, whereas base current changed from 20 μ A to 25 μ A value. If transistor is in active state, small signal current gain (current amplification factor) will be :

- (A) 240 (B) 400
(C) 0.0025 (D) 200

Official Ans. by NTA (B)

Ans. (B)

Sol. $V_{CE} = 8 \text{ V} = I_C = 6 \text{ mA}$ from 4 mA,

$$I_B = 20 \mu\text{A} \text{ to } 25 \mu\text{A}$$

$$\text{Current gain } \beta_{av} = \frac{I_C' - I_C}{I_B' - I_B} = \frac{2 \text{ mA}}{5 \mu\text{A}}$$

$$\beta_{av} = \frac{2}{5} \times 10^3 = \frac{2000}{5} = 400$$

20. A square wave of the modulating signal is shown in the figure. The carrier wave is given by $C(t) = 5 \sin(8\pi t)$ Volt. The modulation index is :

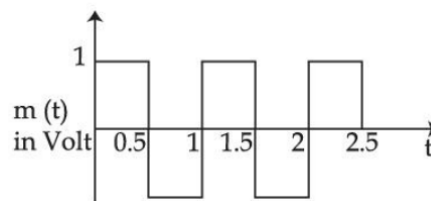

- (A) 0.2 (B) 0.1
(C) 0.3 (D) 0.4

Official Ans. by NTA (A)

Ans. (A)

Sol. Modulation Index $\mu = \frac{A_m}{A_C} = \frac{1}{5} = 0.2$

A_m = amp. of modulating signal

A_C = amp. of carrier wave

SECTION-B

1. In an experiment to determine the Young's modulus, steel wires of five different lengths (1, 2, 3, 4 and 5 m) but of same cross section (2 mm^2) were taken and curves between extension and load were obtained. The slope (extension/load) of the curves were plotted with the wire length and the following graph is obtained. If the Young's modulus of given steel wires is $x \times 10^{11} \text{ Nm}^{-2}$, then the value of x is _____.

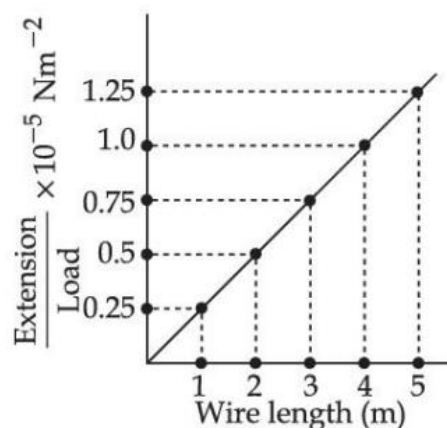

Official Ans. by NTA (2)

Ans. (2)

Sol. $\text{Slope} = \frac{\Delta l / w}{L} = \frac{\Delta l / L}{w} = \frac{1}{YA}$

$\Rightarrow Y = \frac{1}{(\text{slope})A}$

$Y = \frac{1}{2 \times 10^{-6} (0.25 \times 10^{-5})}$

$Y = 2 \times 10^{11} \text{ N/m}^2$

2. In the given figure of meter bridge experiment, the balancing length AC corresponding to null deflection of the galvanometer is 40 cm. The balancing length, if the radius of the wire AB is doubled, will be.....cm.

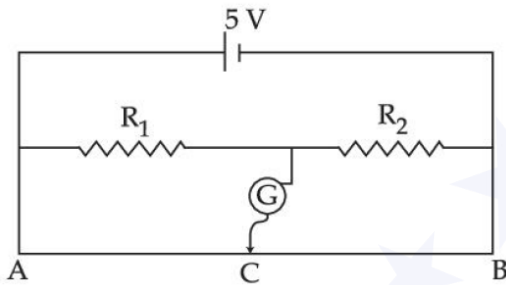

Official Ans. by NTA (40)

Ans. (40)

Sol. Independent of area in case of uniform wire.

3. A thin prism of angle 6° and refractive index for yellow light (n_Y) 1.5 is combined with another prism of angle 5° and $n_Y = 1.55$. The combination produces no dispersion. The net average deviation (δ) produced by the combination is $\left(\frac{1}{x}\right)^\circ$. The value of x is.....

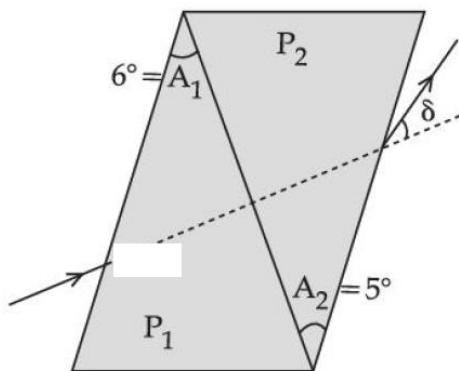

Official Ans. by NTA (4)

Ans. (4)

Sol. $\delta = A(\mu_y - 1) - A'(\mu_y' - 1)$
 $= 6(1.5 - 1) - 5(1.55 - 1)$
 $= \frac{1}{4}$

4. A conducting circular loop is placed in X - Y plane in presence of magnetic field $\vec{B} = (3t^3\hat{j} + 3t^2\hat{k})$ in SI unit. If the radius of the loop is 1m, the induced emf in the loop, at time, $t = 2$ s is $n\pi$ V. The value of n is.....

Official Ans. by NTA (12)

Ans. (12)

Sol. $\phi = \vec{B} \cdot \vec{A}$
 $= (3t^3\hat{j} + 3t^2\hat{k}) \cdot (\pi(1)^2\hat{k})$
 $\phi = 3t^2\pi$

$\epsilon_{\text{IND}} = \left| \frac{d\phi}{dt} \right| = 6t\pi$

at $t = 2$, $\epsilon_{\text{IND}} = 12$

5. As show in the figure, in steady state, the charge stored in the capacitor is..... $\times 10^{-6}$ C.

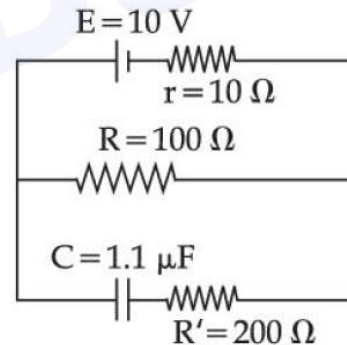

Official Ans. by NTA (10)

Ans. (10)

Sol. $q = C V_{100\Omega}$
 $= (1.1 \times 10^{-6}) \left(\frac{10}{R + r} R \right)$
 $= 1.1 \times 10^{-6} \left(\frac{10}{110} \times 100 \right)$
 $= 10 \mu\text{C}$

6. A parallel plate capacitor with width 4 cm, length 8 cm and separation between the plates of 4mm is connected to a battery of 20 V. A dielectric slab of dielectric constant 5 having length 1cm, width 4 cm and thickness 4 mm is inserted between the plates of parallel plate capacitor. The electrostatic energy of this system will be..... ϵ_0 J. (Where ϵ_0 is the permittivity of free space)

Official Ans. by NTA (240)

Ans. (240)

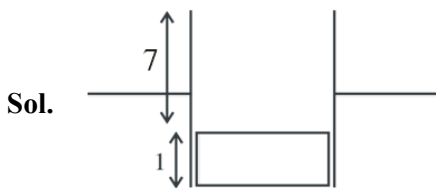

$$C_{\text{eff}} = \left[\frac{\epsilon_0(7 \times 4)}{4/10} + \frac{5\epsilon_0(1 \times 4)}{4/10} \right] \times 10^{-2}$$

$$C_{\text{eff}} = 1.2\epsilon_0$$

$$\text{Energy} = \frac{1}{2} C_{\text{eff}} V^2$$

$$= \frac{1}{2} (1.2)\epsilon_0 (20)(20) = 240\epsilon_0$$

7. A wire of length 30 cm, stretched between rigid supports, has its n^{th} and $(n + 1)^{\text{th}}$ harmonics at 400 Hz and 450 Hz, respectively. If tension in the string is 2700 N, its linear mass density is.....kg/m.

Official Ans. by NTA (3)

Ans. (3)

Sol. $\frac{nv}{0.6} = 400$ & $\frac{(n+1)v}{0.6} = 450$

$$\Rightarrow \left[\frac{0.6 \times 400}{v} + 1 \right] \frac{v}{0.6} = 450$$

$$\Rightarrow v = 30$$

$$\Rightarrow \sqrt{\frac{T}{\mu}} = 30$$

$$\Rightarrow \frac{2700}{\mu} = 900 = \mu = 3$$

8. A spherical soap bubble of radius 3 cm is formed inside another spherical soap bubble of radius 6 cm. If the internal pressure of the smaller bubble of radius 3 cm in the above system is equal to the internal pressure of the another single soap bubble of radius r cm. The value of r is.....

Official Ans. by NTA (2)

Ans. (2)

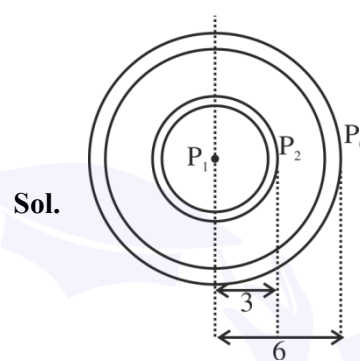

$$P_2 - P_0 = \frac{4T}{6} \quad \& \quad P_1 - P_2 = \frac{4T}{3}$$

$$\Rightarrow P_1 - P_0 = \frac{4T}{2} = 2$$

9. A solid cylinder length is suspended symmetrically through two massless strings, as shown in the figure. The distance from the initial rest position, the cylinder should by unbinding the strings to achieve a speed of 4 ms^{-1} , is.....cm.

(take $g = 10 \text{ ms}^{-2}$)

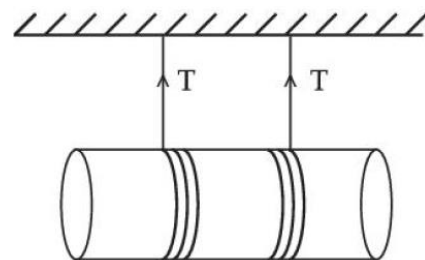

Official Ans. by NTA (120)

Ans. (120)

Sol. From energy conservation

$$mgh = \frac{1}{2}mv^2 + \frac{1}{2}I\omega^2$$

$$mgh = \frac{1}{2}mv^2 + \frac{1}{2} \frac{mR^2}{2} \omega^2$$

$$10h = \frac{16}{2} + \frac{16}{4} \Rightarrow h = 1.2\text{m} = 120\text{cm}$$

10. Two inclined planes are placed as shown in figure.

A block is projected from the Point A of inclined plane AB along its surface with a velocity just sufficient to carry it to the top Point B at a height 10 m. After reaching the Point B the block slides down on inclined plane BC. Time it takes to reach to the point C from point A is $t(\sqrt{2}+1)$ s. The value of t is.....(use $g = 10 \text{ m/s}^2$)

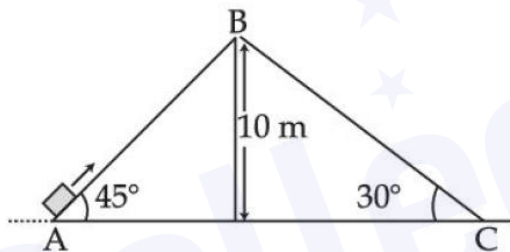

Official Ans. by NTA (2)

Ans. (2)

Sol.

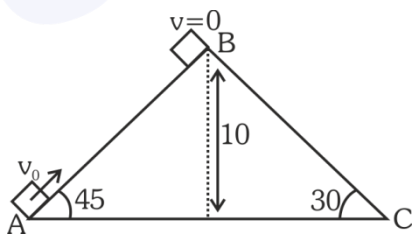

$$\text{From E.C.} = \frac{1}{2}mv_0^2 = mgh$$

$$v_0 = 10\sqrt{2}$$

For A \rightarrow B

at B, $v = 0$

$$a = -g \sin 45^\circ = \frac{-10}{\sqrt{2}}$$

$$v = u + at_1 \Rightarrow 0 = 10\sqrt{2} - \frac{10}{\sqrt{2}}t_1 \Rightarrow t_1 = 2 \text{ sec}$$

For B \rightarrow C

$$s = ut_2 + \frac{1}{2}at_2^2$$

$$\frac{10}{\sin 30^\circ} = \frac{1}{2}(10 \sin 30^\circ)t_2^2$$

$$t_2 = 2\sqrt{2}$$

So total time

$$T = t_1 + t_2$$

$$= 2\sqrt{2} + 2$$

$$= 2(\sqrt{2} + 1) \text{ sec}$$