

Common Entrance Examination for Design

CEED 2019

Question Paper



Indian Institute of Technology Bombay

INSTRUCTIONS

- The total duration of the examination is 3 hours. The question paper contains two parts - Part A and Part B. The duration of Part A is one hour. The duration of Part B is two hours. Part B will start only after Part A ends. Part A cannot be attempted after Part B commences.
- Questions of Part A and Part B will appear on the computer. Answers to **Part A** have to be entered in the **computer**. Answers to **Part B** have to be given in the **answer booklet** provided by the invigilator.
- Part A carries a total of 100 marks. It contains 3 sections. The following table summarises the number of questions in each section, type of questions, marks for correct answers, marks for wrong answers, marks for questions not attempted and total marks for the section:

Part A Section	Type of questions	Number of questions	Marks for each correct answer	Marks for each wrong answer	Marks for each question not attempted	Total marks for the section
I	Numerical Answer Type (NAT)	10	3	0	0	30
II	Multiple Select Question (MSQ)	10	2	0	0	20
III	Multiple Choice Question (MCQ)	25	2	-0.6	0	50

- For each NAT question, the answer is a **real number with decimal digits up to two decimal places**. The answer needs to be entered using the virtual keyboard on the monitor. No choices will be shown for these questions. There is no negative or partial marking for NAT questions.
- Each MSQ has four choices of which **one or more** is/are the correct answer(s). The marks will be awarded only if **all the correct choices** are selected. There is no negative or partial marking for MSQs.
- Each MCQ has four choices of which **only one** is the correct answer. In MCQs, the correct answer will be awarded **2 marks** and wrong answer will be awarded **-0.6 marks**. Questions not attempted will be awarded zero marks.
- Scribble pads will be provided for rough work for Part A. These have to be returned to the invigilator at the **end of the Part A exam**.
- Part B carries a total of 100 marks. It contains 8 questions. You may choose to answer any ONE of Questions 1, 2, 3, 4 and 5. Questions 6, 7 and 8 are mandatory. Each question must be answered on the page(s) designated for that question in the answer booklet. Additional instructions to Part B questions are provided in the answer booklet.
- In Part B, colour pencils, crayons, sketch pens etc. may be used unless otherwise specified in the questions.
- Charts, graph sheets, mathematical tables, calculators, mobile phones, and other electronic gadgets are not allowed in the examination hall.

Part A – Section I: Numerical Answer Type Questions

Q.01 All the four-digit numbers except one is written using a single font. Identify the number that does not use the same font as the other numbers.

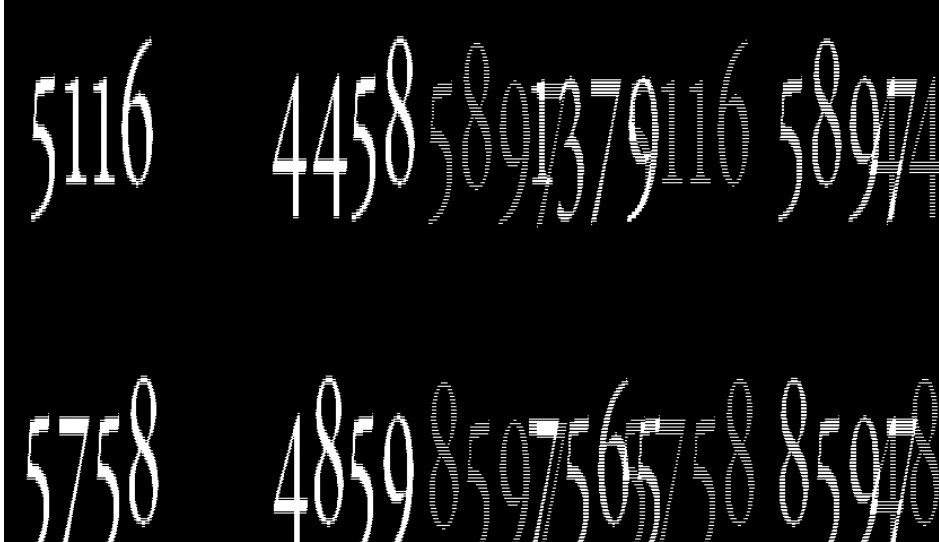

Q.02 Find the number which will replace the question mark.

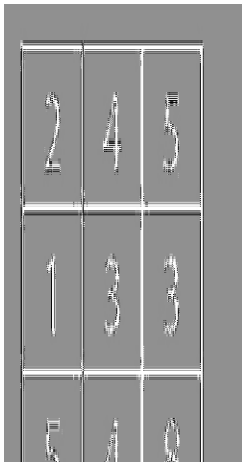

Q.03 An intersection is a point where two or more lines/curves meet or cross. How many intersections are there in the figure given below?

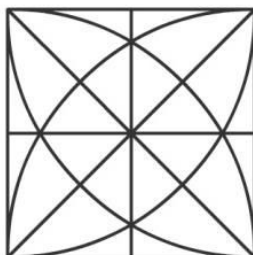

Q.04 How much distance (in cm) will the bicycle shown below travel, if the pedal makes 1.5 revolutions? (Assume $\pi = 22/7$).

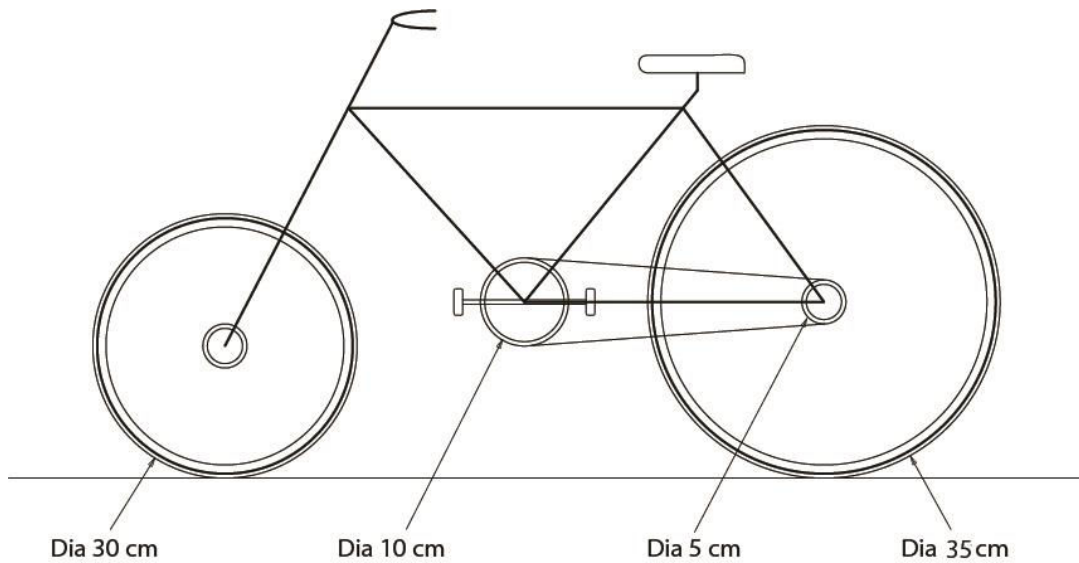

Q.05 How many glasses will remain empty if you half-fill some of the empty glasses, from the given set of filled glasses?

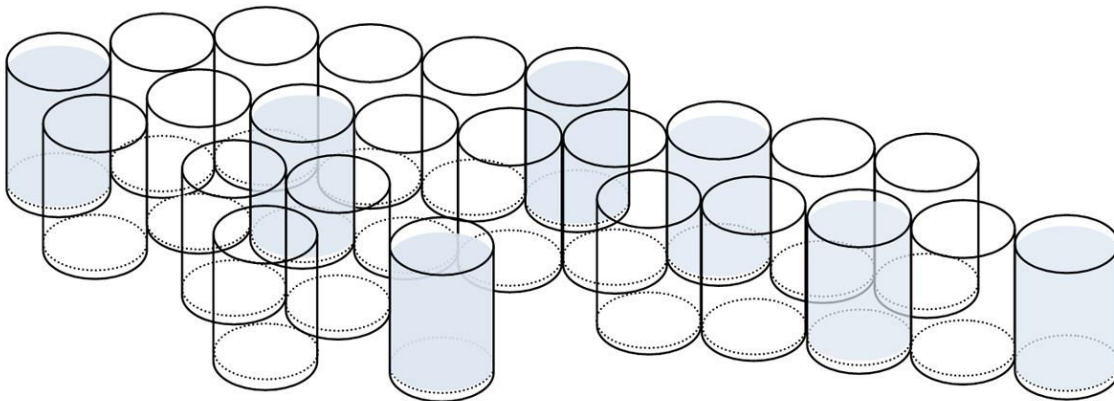

Q.06 Two perspective views of the same solid object are shown below. How many surfaces does the object contain? Assume hidden surfaces to be flat.

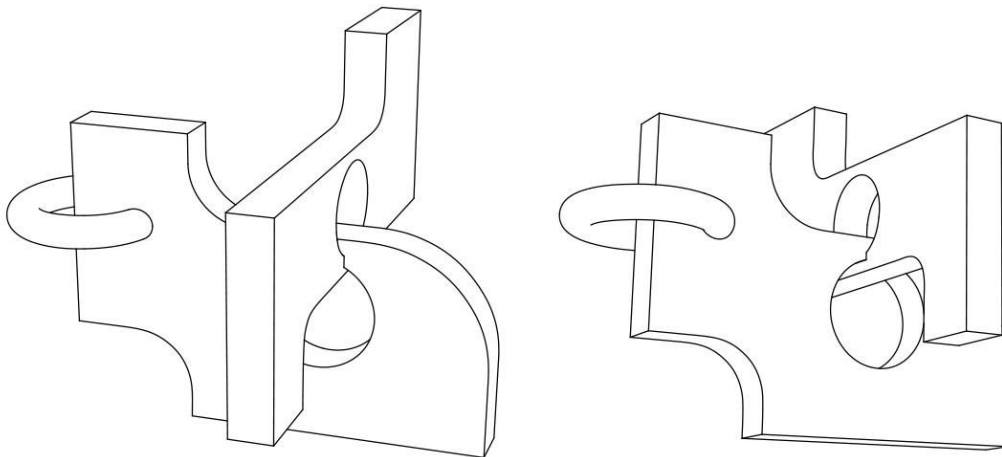

Q.07 Two water tanks A and B of equal square base of sides 3 feet are shown below. Water flows from tank A to tank B through a tube. What will be the volume (in cubic feet) of water in Tank A when the water stops flowing?

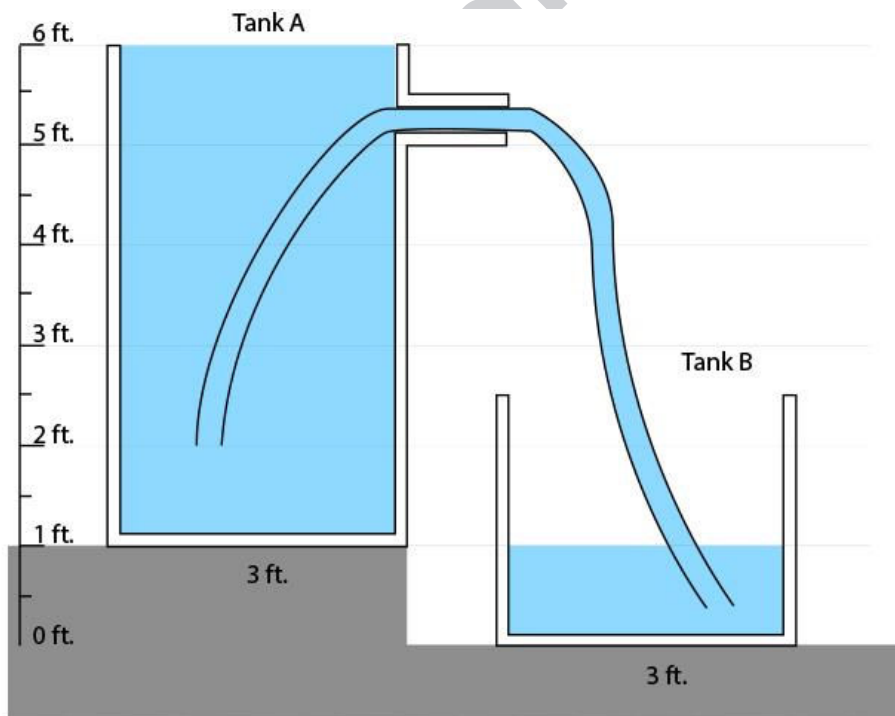

Q.08 A solid is shown in the figure below. The vertices ABCDEFGH form a $4\text{ cm} \times 2\text{ cm} \times 2\text{ cm}$ cuboid. The segments AI and DI are both of length 5 cm, and points ICGFB are coplanar. What is the height (in cm) of point I from the base rectangle EFGH?

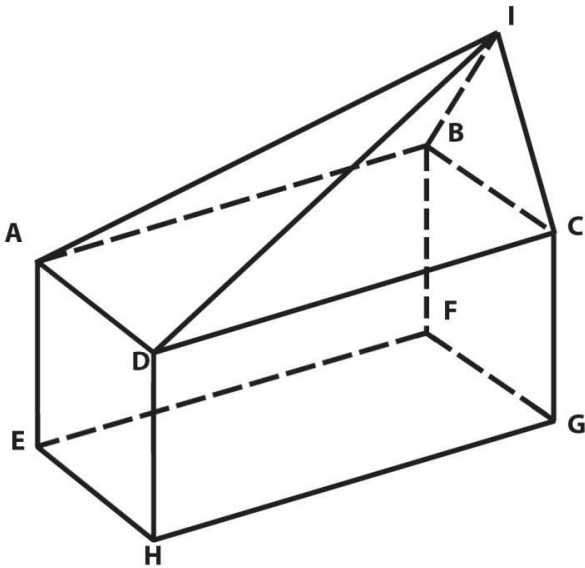

Q.09 The figure shows the front view of a convex lens, which originally had only one edge. Five holes of different shapes, namely triangle, square, pentagon, hexagon and circle, were drilled through it at points P, Q, R, S and T in such a way that the holes were parallel to each other, perpendicular to the edge and all the holes were still within the lens edge. What is the total number of edges in the lens after the holes were drilled?

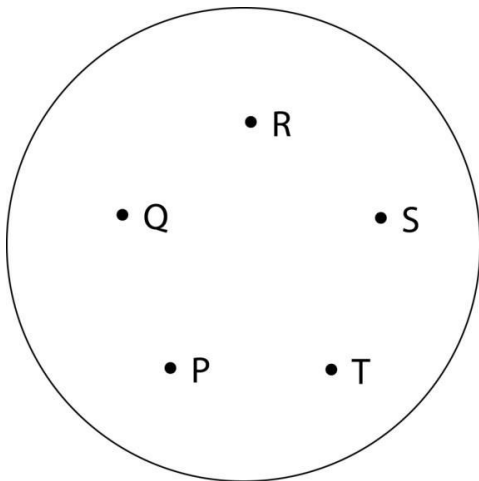

Q.10 In terms of calories, 20 jamuns and 3 bananas combined are equivalent to one mango and one papaya combined, and 2 mangoes and 5 bananas combined are equivalent to 4 papayas and 80 jamuns combined. Then 8 papayas and 2 mangoes are equivalent to how many bananas?

Part A – Section II: Multiple Select Questions

Q.11 A designer has designed a logo. The form is shown on the left and its accompanying text is shown on the right. Which of the following statements about this logo is/are TRUE?



Adgula
अडगुल

- A. If this logo is printed on an envelope with a 60 DPI dot-matrix printer, such that the total height of the logo is 2 cm, then the logo will retain its original form.
- B. If this logo is printed on a flex sheet with a 720 DPI flex printer such that the total height of the logo is 15 ft, then the logo will retain its original form.
- C. This logo can be reproduced as shown above by using a four colour screen printing process.
- D. The visual properties of the English font match the visual properties of the Hindi font.

Q.12 Image P shows a portion of a larger photograph. Some operations have been done on that photograph using an image manipulation software. Image Q shows a portion of the resulting photograph. Identify the option(s) that specifies/specify the correct operations.



P

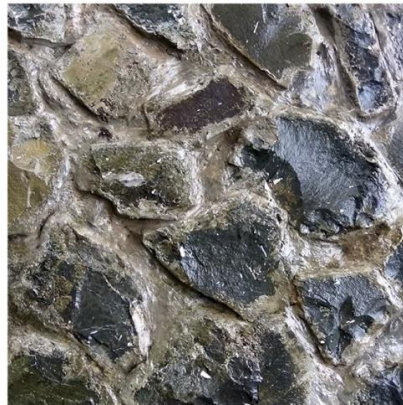

Q

- A. Rotate clockwise by 45 degrees, flip horizontally, then rotate clockwise by 90 degrees
- B. Rotate clockwise by 135 degrees, flip horizontally
- C. Rotate clockwise by 135 degrees, flip vertically
- D. Rotate clockwise by 90 degrees, flip horizontally, then rotate clockwise by 45 degrees

Q.13 If you are asked to draw the following four figures with the following constraints: They must be drawn in a single stroke (without lifting the pen from paper), and each line is drawn only once. Which of the options can be drawn?

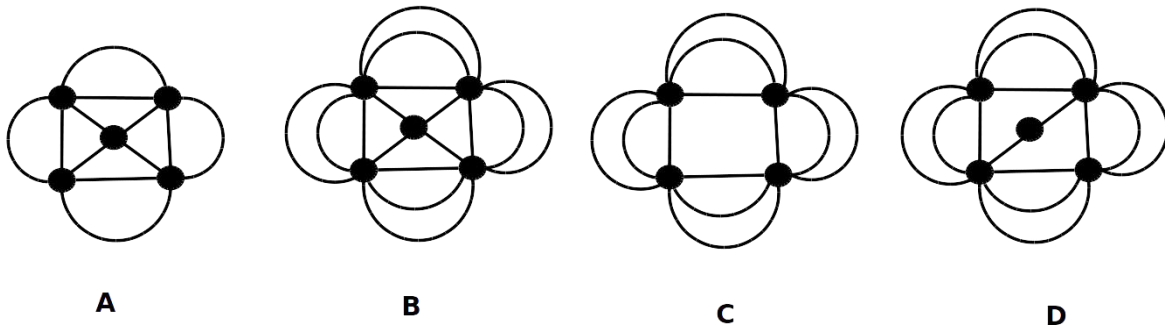

Q.14 The pie chart shows proportions of income tax paid by a population of eight individuals. Each individual's tax share is shown in a different slice of the pie. Which of the statements can be derived from the chart shown below?

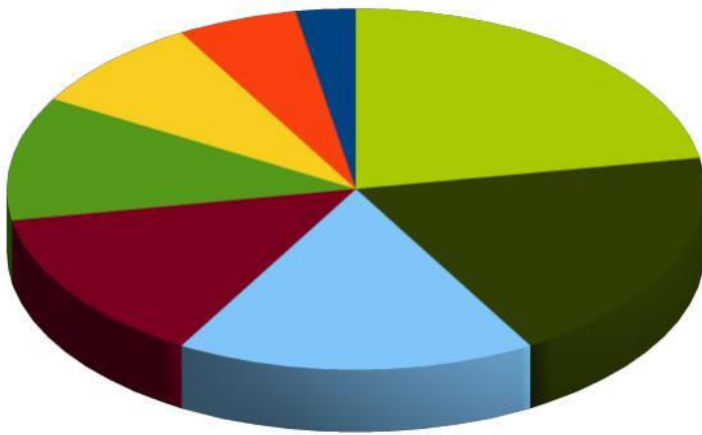

- A. About half the total tax is paid by less than half of the population.
- B. About half the total tax is paid by more than half of the population.
- C. About three-fourth of the tax is paid by three-fourth of the population.
- D. Some individuals paid more than double the taxes as compared to some others.

Q.15 Four square table-tops of the same dimensions are shown below. Only the designs of their supports are different from each other. If a person stands upright on the red mark on each of the table, which of the tables will topple?

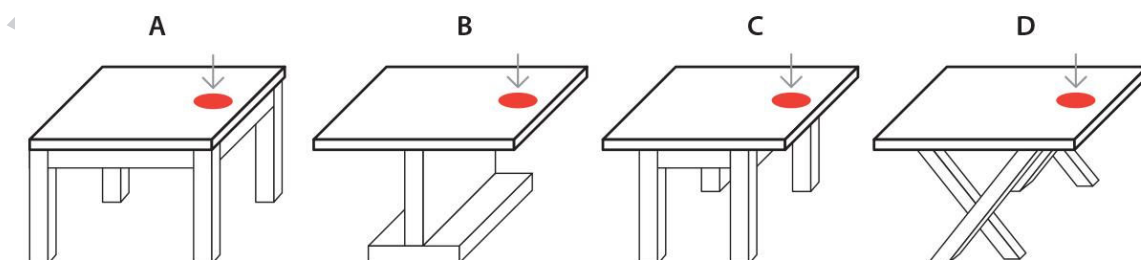

Q.16 A glass cube with 27 equal compartments is filled with water. There are a few red balls floating inside the compartments. Three views of the cube are shown below. Identify the red ball(s) that is/are represented incorrectly in the top view.

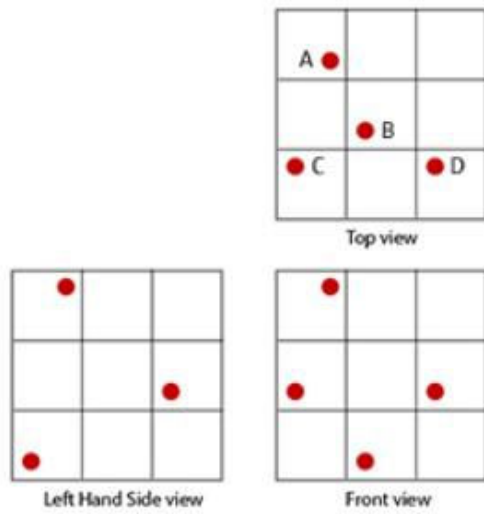

Q.17 Which of the options is/are simple rotations of the figure given below?

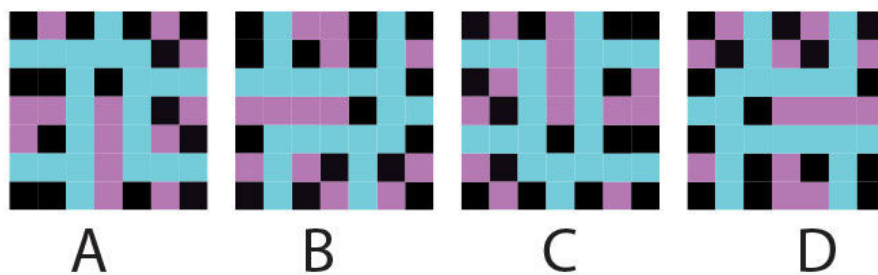
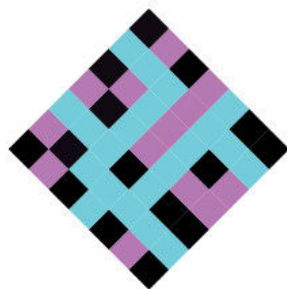

Q.18 Which of the following drawings illustrate(s) the use of the animation principle of “Squash and Stretch”?

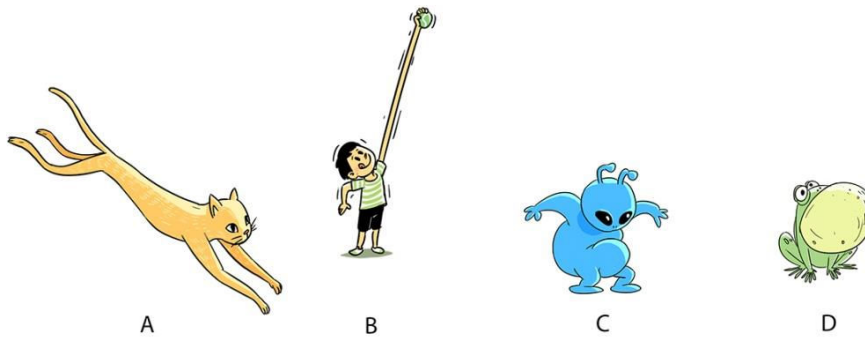

Q.19 Monitors with different resolutions can be attached to a computer. The computer can also render a video at various resolutions. Assuming that the videos are played at 1:1 resolution, which of the following options is/are TRUE?

- A. Given a video, a monitor with a higher resolution will display it in a smaller size than a monitor with lower resolution.
- B. Given a video, a monitor with a higher resolution will display it in a bigger size than a monitor with lower resolution.
- C. Given a monitor, a video with higher resolution will be visible in a smaller size than a video with a lower resolution.
- D. Given a monitor, a video with higher resolution will be visible in a bigger size than a video with a lower resolution.

Q.20 If all the lines in the image below are of the same length but of different thickness and are drawn in perspective with respect to their distance from the viewer, which of the following statements will be TRUE?

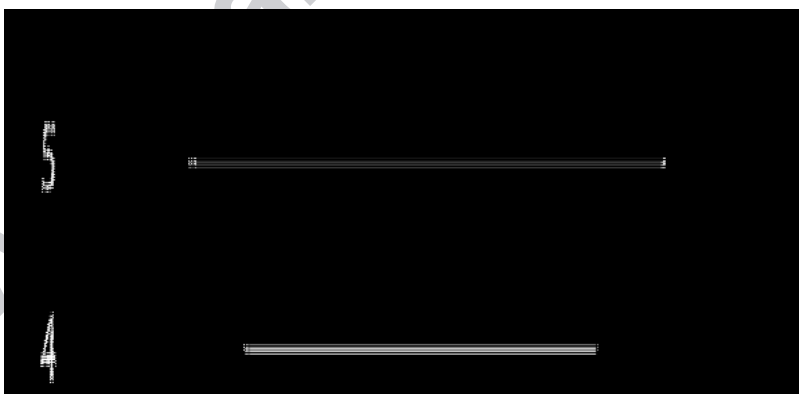

- A. Line 1 is the thickest line of all
- B. Four lines are of same thickness
- C. Line 2 and line 3 have same thickness
- D. Line 3 is the closest line of all to the viewer

Part A – Section III: Multiple Choice Questions

Q.21 Identify the correct font used for Parle-G biscuits.



Q.22 Identify the option that will replace the question mark.

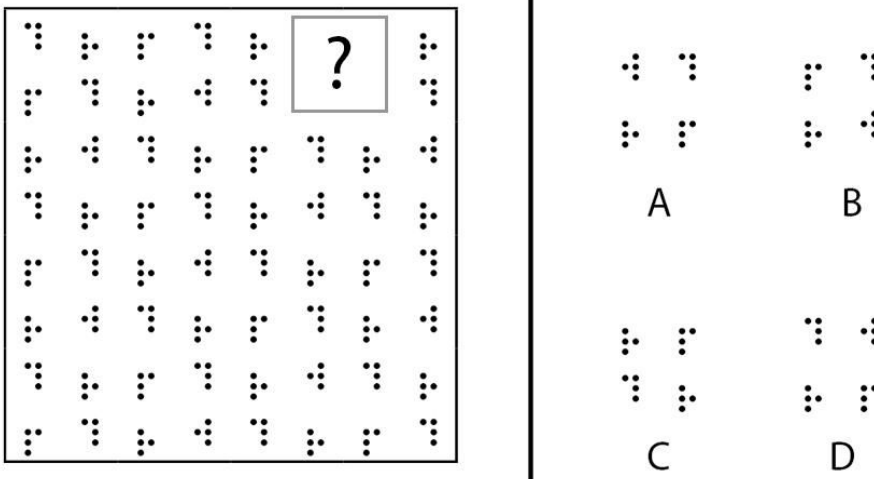

Q.23 Identify the option that will replace the question mark.

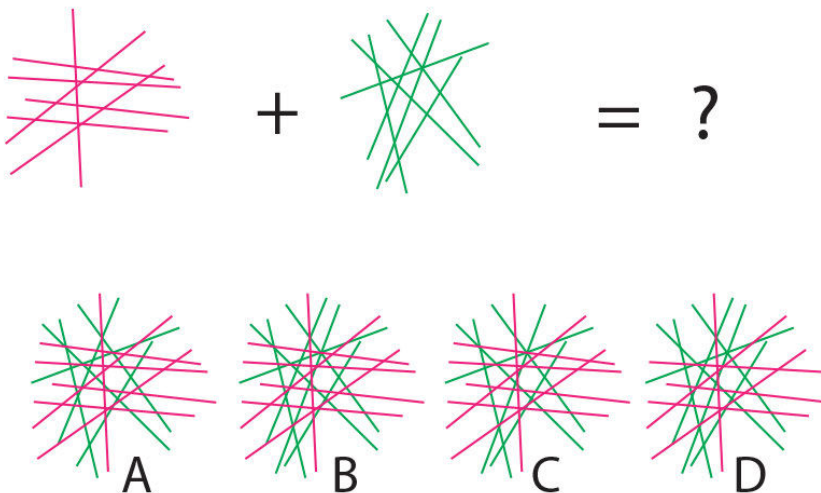

Q.24 Shahid is feeling very sleepy. He yawns and stretches. Identify the correct image.

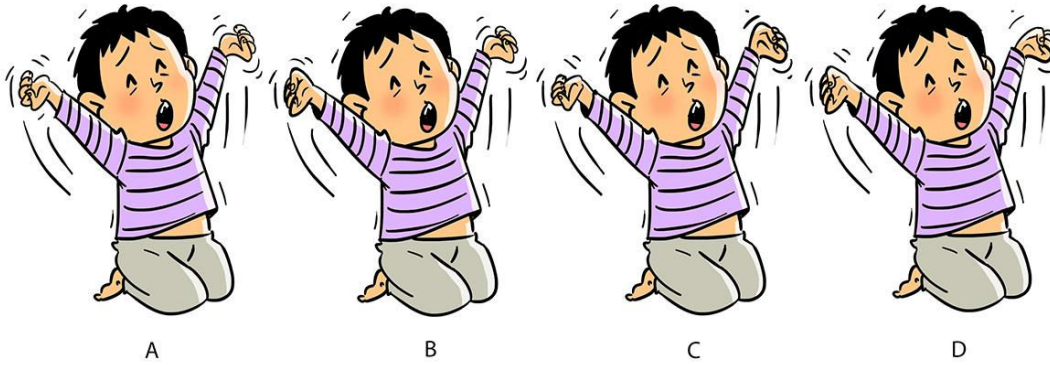

Q.25 Which is the correct representation of the posture of a house lizard as it climbs a wall?

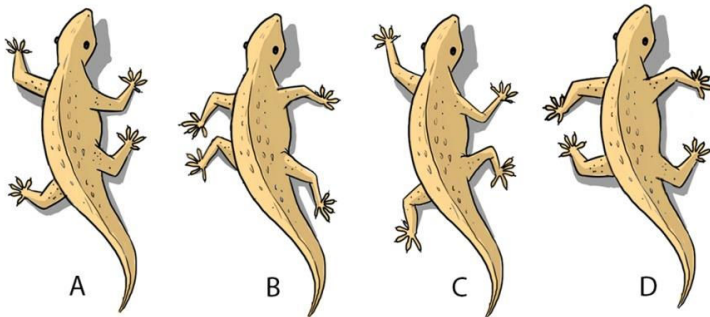

Q.26 Which of the given configurations of *Palki* (Pallanquin) will work the best for the traveller as well as for the labourers carrying the traveller?

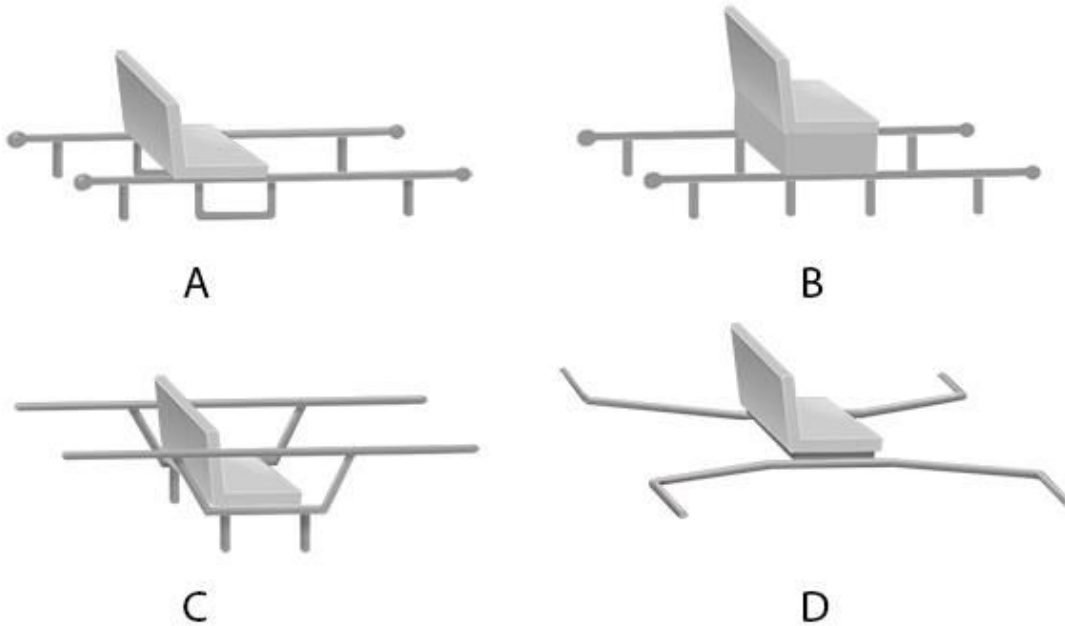

Q.27 A hollow circular pipe with non-reflective inner surface is cut into 5 pieces and arranged as shown in the figure below. If it is illuminated from below using a torch as shown in the figure, what would be the profile of the light falling on the sheet kept above?

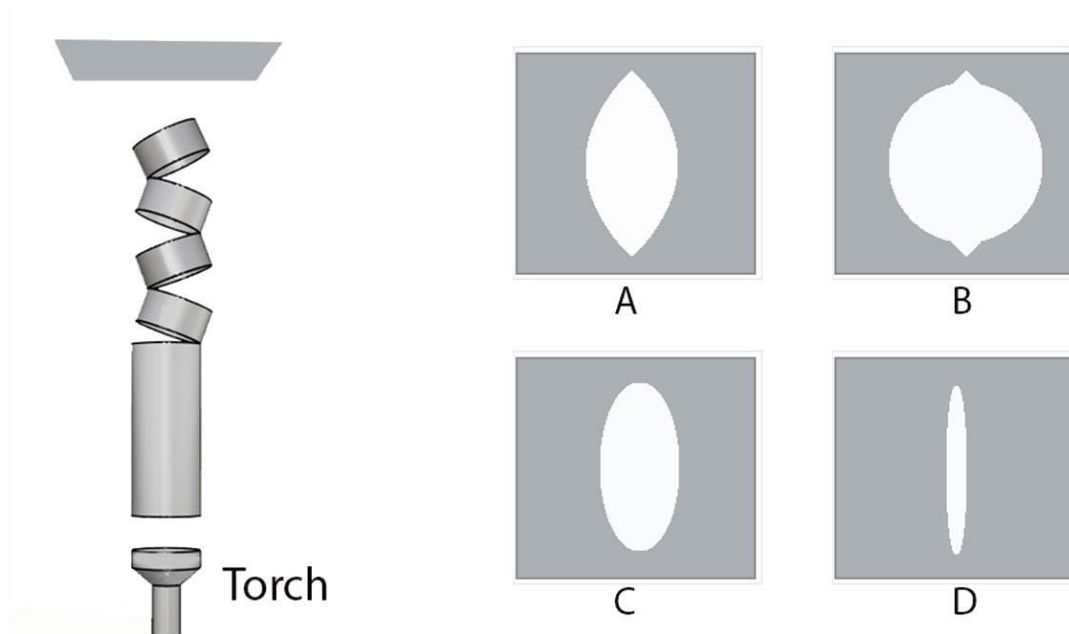

Q.28 From a 3-dimensional structure made of cubes, eight rows of cubes have been removed as shown below. Select the correct pattern that will emerge from the side shown with an arrow.

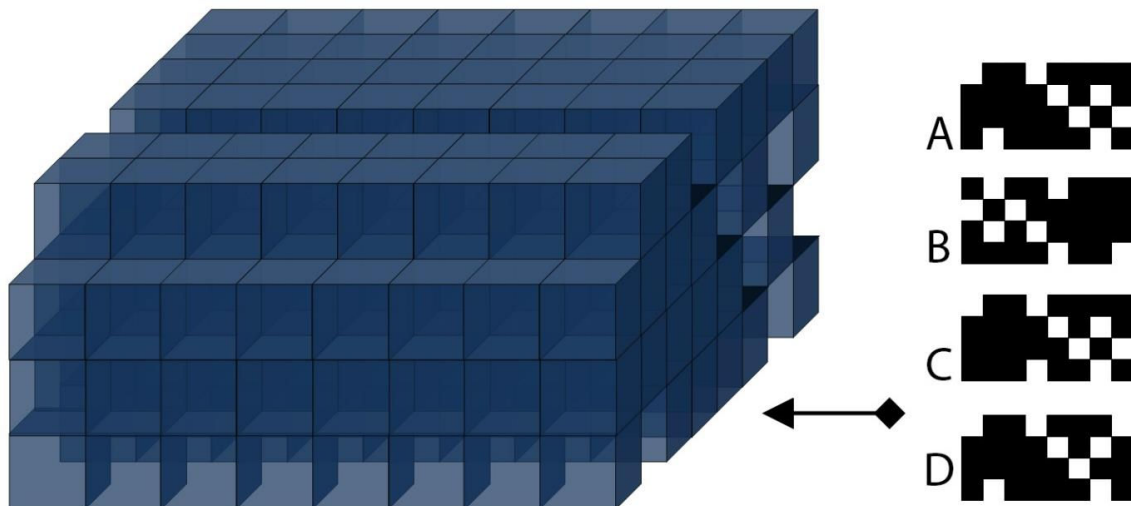

Q.29 Perspective view of an object is shown below. The object is rotated 90 degrees anticlockwise about z-axis (when viewed from a point on the positive z-axis towards the origin) and then rotated 180 degrees about x-axis (when viewed from a point on the positive x-axis towards the origin). Which one of the following perspective view options will be the result of the rotations?

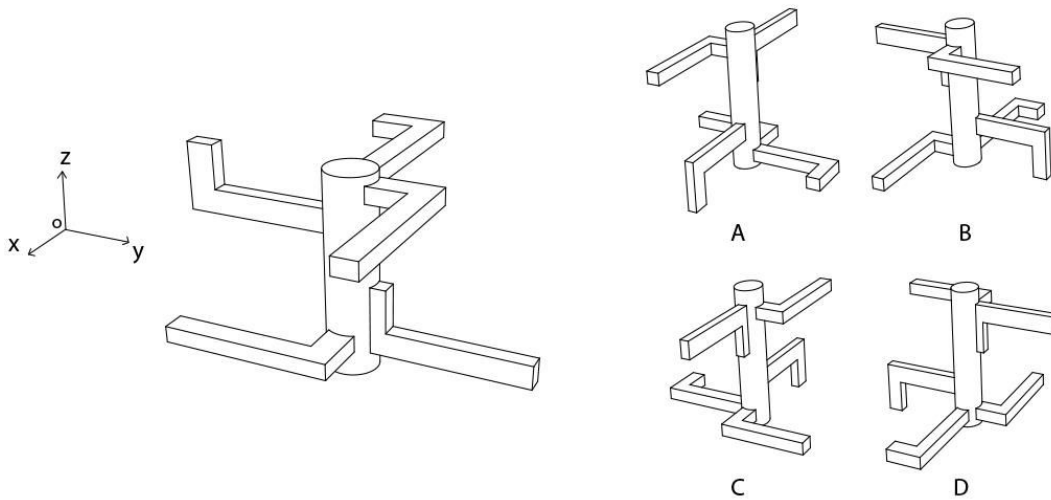

Q.30 A square paper is folded and cut as shown below. The paper is then used as a template to spray-paint a white wall with black paint. Which pattern would be created using this template?

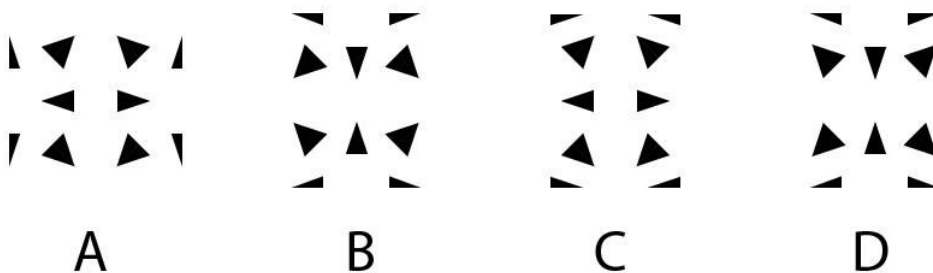
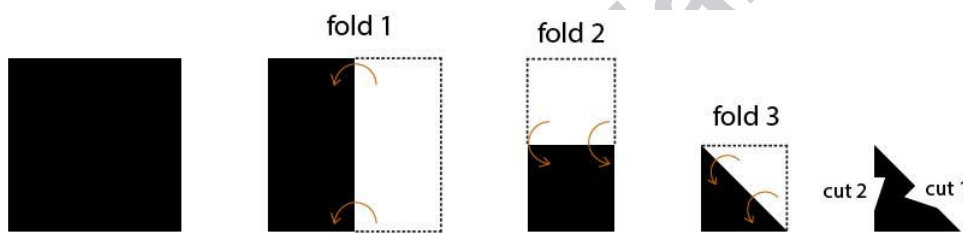

Q.31 In a camera, the opening through which light enters the camera is called aperture. The distance between the closest and the farthest part of a view captured on a photograph, which is in focus, is called depth of field. Given that all other settings remain the same, which of the following is TRUE?

- A. The larger the aperture, the larger the depth of field
- B. The smaller the aperture, the larger the depth of field
- C. The depth of field is not affected by the aperture size
- D. Larger the aperture, the larger the image captured

Q.32 Identify the option that will replace the question mark.

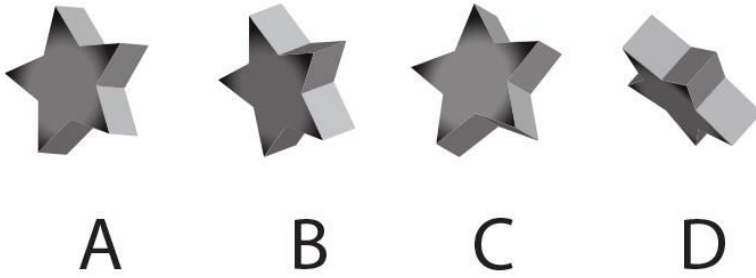

Q.33 A cat is sitting on a wall on the left side of a house. Identify the correct option that shows the cat's point of view as it looks at the house?

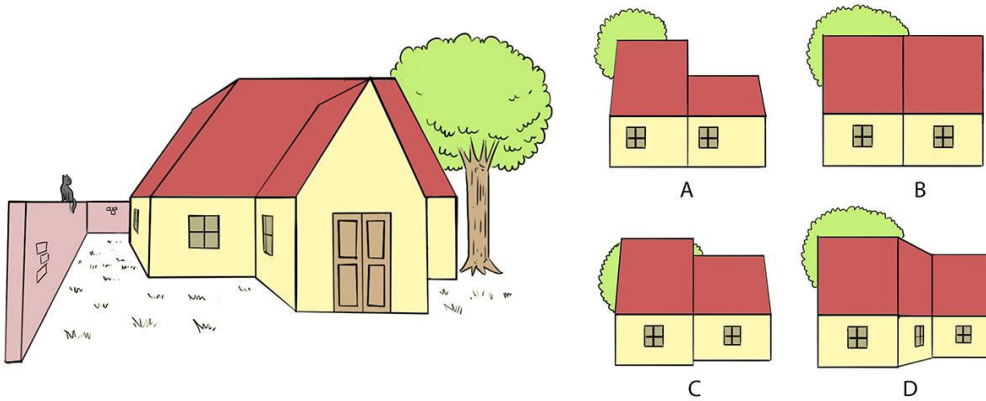

Q.34 Identify the option that will replace the question mark.

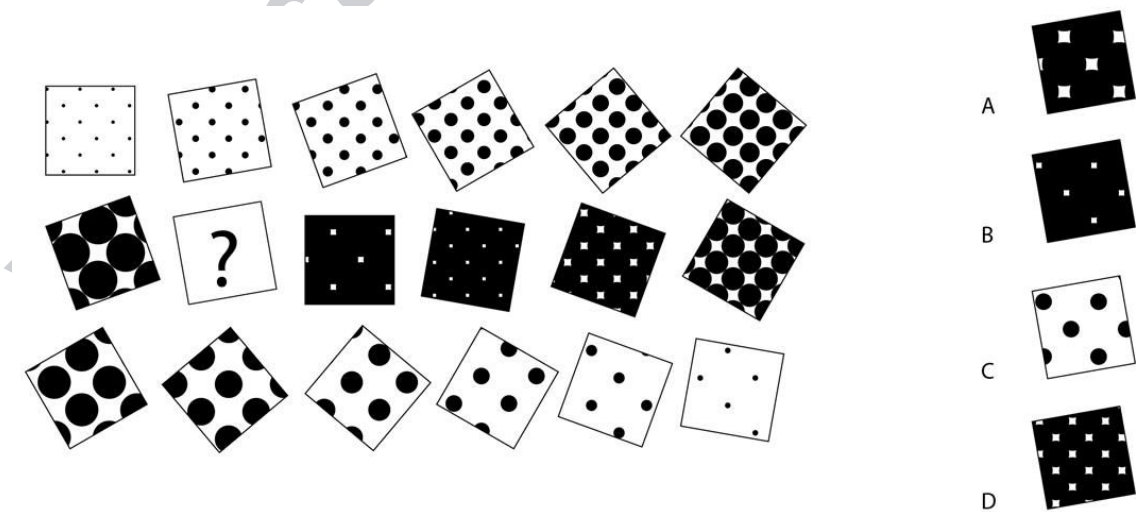

Q.35 Images of traditional products of certain states of India are shown below. Identify the correct set of states to which these belong. Names of the states are in a random sequence. The products are made out of clay, willow/wicker, wood and brass.



- A. Maharashtra, Nagaland, Jammu & Kashmir, Chhattisgarh
- B. Nagaland, Jammu & Kashmir, Chhattisgarh, Andhra Pradesh
- C. Jammu & Kashmir, Kerala, Andhra Pradesh, Haryana
- D. Maharashtra, Kerala, Andhra Pradesh, Haryana

Q.36 Refer to the following image of a wooden artefact made using traditional manual tools, skills and processes. Identify the correct set of operations required to make it. The operations in the options are in a random order.



- A. Drilling, Chiselling, Casting, Cutting
- B. Chiselling, Milling, Punching, Forming
- C. Drilling, Chiselling, Cutting, Finishing
- D. Finishing, Sanding, Forming, Punching

Q.37 Refer to the chairs shown below. Which of the following statements is TRUE?



- A. R has deer elements, Q has bird elements, only P has human elements
- B. Only Q has bird elements, R has deer elements, only S and P have human elements
- C. Only Q and S have curved surfaces, Q has bird elements, only S has human elements
- D. R and S have animal elements , Q has bird, only P has human elements

Q.38 How many right-angled triangles are there in the given image?

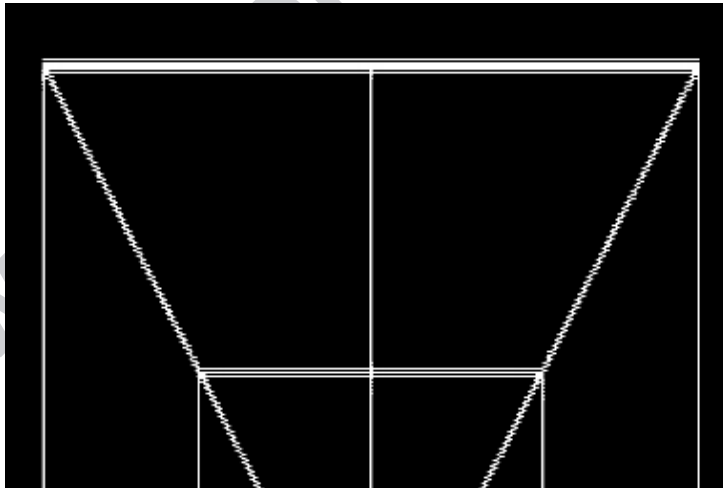

- A. 20
- B. 24
- C. 28
- D. 32

Q.39 A solid created by rotating a planar-shape about an axis is called a “Surface of Revolution”. The figure below shows a shape and the axis of revolution which is used to create such a solid. Which of the options would be the correct top view of this solid?

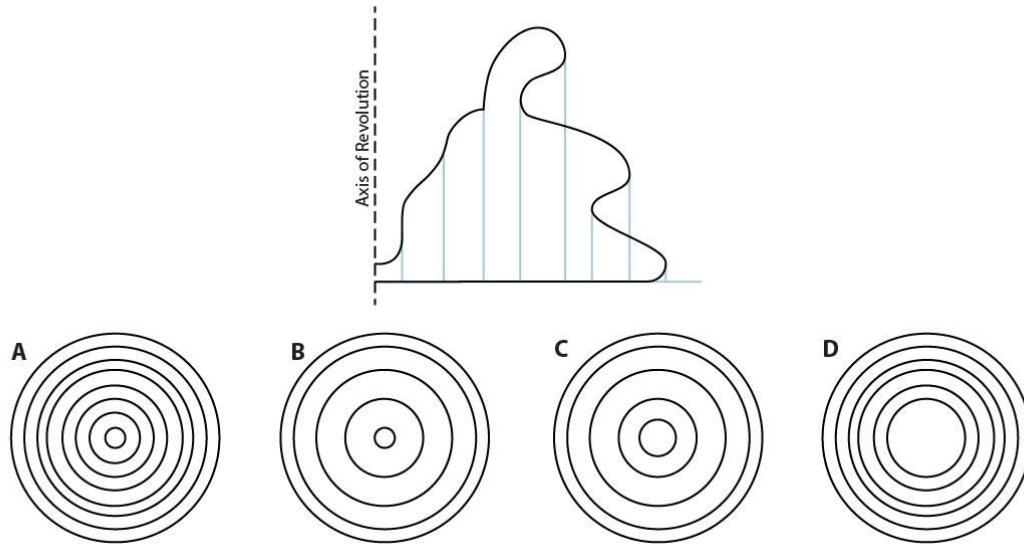

Q.40 Identify the option that will replace the question mark.



Q.41 A 3D illusion painting is created on a road. Shown on the left is how it appears to a viewer in perspective. If this illusion has to be sketched on paper, before it is painted, which one of the options on the right would be correct?

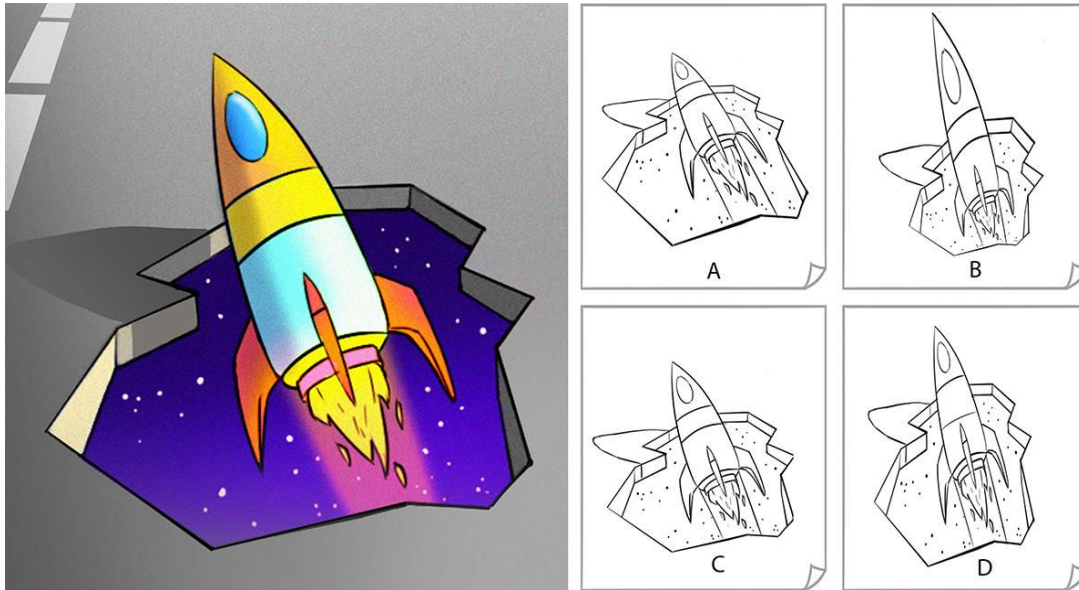

Q.42 Fill in the blanks to keep the sentence grammatically correct as well as meaningful.

..... the facts, she proceeded with her decision, finally ending up with a situation.

- A. Nevertheless, happy
- B. Apparently, initially
- C. However, noteworthy
- D. Notwithstanding, sad

Q.43 Match the following.

<p>1. </p> <p>2. </p> <p>3. </p> <p>4. </p>	<p>P. Complementary</p> <p>Q. Spectrum</p> <p>R. Cool</p> <p>S. Harmony</p>
<div style="text-align: center;"> <p>1Q, 2S, 3R, 4P</p> <p>A</p> </div> <div style="text-align: center;"> <p>1Q, 2R, 3S, 4P</p> <p>B</p> </div> <div style="text-align: center;"> <p>1R, 2P, 3Q, 4S</p> <p>C</p> </div> <div style="text-align: center;"> <p>1P, 2R, 3S, 4Q</p> <p>D</p> </div>	

Q.44 A micro-interaction has been designed for a 'menu' icon. On clicking this icon, it changes into a different icon representing 'back', depicted by an arrow. On another click it changes back to the menu icon. Shown below are 13 key-frames of this animation. Their order is incorrect, but the ones in green are in the correct position. Identify the correct order of this animation.

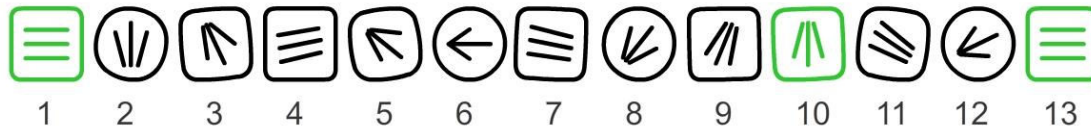

- A. 1, 7, 11, 2, 12, 8, 6, 3, 5, 10, 9, 4, 13
- B. 1, 4, 9, 3, 5, 6, 12, 8, 2, 10, 11, 7, 13
- C. 1, 7, 11, 2, 8, 12, 6, 5, 3, 10, 9, 4, 13
- D. 1, 4, 9, 3, 5, 6, 8, 12, 2, 10, 11, 7, 13

Q.45 Imagine a possibility of an emergency evacuation scenario in a domestic household in India. The height at which the inside latch of the exit-door should be installed is to be finalised. It is required to disallow opening of the door accidentally by children. Which option will determine the height at which the latch should be fixed? Assume the height of the tallest child is lower than that of the shortest adult.

- A. The height of the tallest adult in the family.
- B. The height of the shortest adult in the family.
- C. The average height of the child in the family.
- D. The average height of the tallest adult male and tallest adult female.

Part B

Answer **ANY ONE** question out of the question numbers 1, 2, 3, 4, and 5. (40 marks)

Q.1 Industrial Design

During the monsoon season, drying of washed clothes at home takes a long time. The interior of the house is usually very damp. It is observed that people tend to spread the wet clothes on a chair or other furniture below a ceiling fan, to dry them. Such temporary arrangements help them cope with the problem.

A leading fan manufacturing company sees a business opportunity. The company approaches you to design a product for drying clothes. The manufacturer proposes to sell this product (which is to be used during monsoons) along with a fan.

The manufacturer wants the following objectives to be met in the design:

- a) The product uses a fan for drying clothes.
- b) The fan must be integrated with the product during its use in rainy season and must be usable as a “normal fan” during other seasons.
- c) The product should be foldable and compact for storage.

Design the product as per the objectives listed above.

1. Present three ideas of design alternatives through rough sketches. (10 marks)
Evaluation Criteria: Quality of creative ideas and neatness of sketches.
2. List ten critical factors (key words only) you will consider for designing. (10 marks)
Evaluation Criteria: Understanding of the situation and product use.
3. Select one of your ideas and develop it into a final product. Make a neat sketch of the same. Indicate all the parts, material and features on this sketch. (20 marks)
Evaluation Criteria: Sketching quality, details, product features and usability issues.

Answer **ANY ONE** question out of the question numbers 1, 2, 3, 4, and 5. (40 marks)

Q.2 Communication Design

Cricket is a popular sport in India. The 12th Cricket World Cup tournament is to be held in England and Wales in 2019. India has already been a champion twice. To win the tournament for a third time, the team needs the support and wishes of a billion Indians.

Design a visual campaign for the Indian cricket team to gather support and encouragement from Indians. As part of the campaign, design a 30 feet x 20 feet hoarding to be placed at prominent locations in various cities and towns.

Task:

1. Through sketches present three completely different concepts/ideas. (10 marks)
Evaluation criteria: Originality and diversity of ideas, creativity, understanding of scale and proportion.
2. Design three slogans for the campaign in English or in any Indian language (with a mention of the language used). (10 marks)
Evaluation criteria: Clarity of message and literary creativity.
3. Make a detailed design of one hoarding with slogan. (20 marks)
Evaluation criteria: Visualisation, quality of lines, composition, colour combinations and detailing.

Answer **ANY ONE** question out of the question numbers 1, 2, 3, 4, and 5. (40 marks)

Q.3 Animation Design

An animation film for children is in the pre-production stage. The film is based on the relationship that develops between a baby and a dog as the baby grows up and the dog gets old. Given below is one scene from the film.

The scene begins with a shot of a dog observing a baby. The baby is hungry and crying.

Suddenly the baby sees something and stops.

On a table, is the baby's milk bottle (and other stuff).

Baby crawls towards the table followed by the curious dog.

The baby reaches out and manages to grab a corner of the table cloth and starts pulling.

The dog's expression changes to one of alarm, as he sees the stuff on the table moving towards the edge.

He leaps forward and grabs the end of the baby's diaper.

Just as the bottle and the other items start toppling over the edge, he pulls the baby away from danger.

The baby is safe, but everything falls on the poor dog.

The mother's scream is heard, "Tommy!! BAD DOG!!" and the dog is seen sheepishly peeping out from under the table cloth, with all the mess around him.

Part 1 (30 marks)

Illustrate (create storyboard of) the above shots as a series of picture frames (at least 10 frames).

You may use more than one frame per shot if you want to. Approximate shape of the frame is shown below.

Note: *The image of the frame did not appear on screen during the examination. Therefore, frames of any proportion will be considered for evaluation.*

Evaluation Criteria: Communication of the narrative through the sequential pictures, shot composition (long shot, close up, top angle, low angle, etc.) and perspective.

Part 2 (10 marks)

Design an image for the poster of the film showing the two characters – the baby and the dog. Your drawings should depict the character and the essence of the film so that it is a good reference for animation and an inspiring image for the animation team.

Evaluation criteria: Illustration skills, the attitude and the expressions, and design of the details in the characters (keeping in mind that this will be used for animation). Your style can be realistic or stylised.

Answer **ANY ONE** question out of the question numbers 1, 2, 3, 4, and 5. (40 marks)

Q.4 Interaction Design

A bicycle manufacturing company has developed a device that will help cyclists find routes and navigate. The device has a colour-display screen (not a touch screen), 7 physical buttons, a speaker, a microphone, a global positioning system (GPS), and a wireless internet connection. The device is water-proof and the display is bright enough to be readable in bright sunlight. The battery of the device gets charged as the cyclist rides the bicycle.

Design a version of this device to be mounted on bicycles for 12 year old children. Your task is to do the following:

- Create a storyboard in 5 steps showing the user interface that enables the user to specify a new destination that he/she has not been to previously. (10 marks)
Evaluation criteria: Appropriateness of the user interface, integration of the hardware and the software and appropriate use of media.
- Present a detailed screenshot showing the information design that helps the user to navigate while riding the bicycle. (10 marks)
Evaluation criteria: Originality, appropriateness of the information design and appropriate use of media.
- Illustrate the shape, size, and position of the screen, the 7 buttons, the speaker, the microphone, and the place where the device will be mounted on the bicycle. (10 marks)
Evaluation criteria: Form, originality and rendering quality.
- Illustrate a scenario in which the device is used for purposes other than the one mentioned above. (10 marks)
Evaluation criteria: Originality, ability to understand the needs and constraints of the users.

Answer **ANY ONE** question out of the question numbers 1, 2, 3, 4, and 5. (40 marks)

Q.5 Mobility and Vehicle Design

There are many local innovative transportation solutions that mostly operate in rural India. These vehicles are flexible to carry large number of people, smaller machine equipments, agro-machinery and even livestock like cattle, goat, etc. These transport systems are neither safe nor comfortable but are indispensable in rural scenarios. At times, these are the only modes of transportation available.

You are expected to think about the context, the target users (needs and expectations), and the purpose of the vehicle, along with aesthetic and safety considerations. Your observations and insights should lead to the development of original solutions. You are free to choose one concept over others, develop the final rendering and detail the key features of the final concept.

Task:

Design a **context sensitive, safe, workable and pleasing 4-wheeler vehicle** for hilly regions that fulfils the following criteria:

- a) Carrying capacity of at least 6 passengers, including the driver.
- b) Has a convertible space that can be used to carry at least 1 cattle/small machine/milk cans/fuel drums and a tool kit. If no goods are transported, the space can also be used to take passengers.
- c) Provides protection with respect to weather conditions (such as sunshades).
- d) Has provisions for easy maintenance.

Present your design proposal as follows:

- Create concept explorations through four good quality design sketches that represent unique design insights. (10 Marks)
Evaluation criteria: Context-sensitivity, identification of problems and challenges, ability to showcase unique design insights, ability to sketch and creation of exploratory concepts.
- Draw a neat freehand perspective sketch of the proposed vehicle concept showing the overall form and its features. (10 marks)
Evaluation criteria: Ability to sketch an automobile in perspective and detail out the final concept.
- Draw a neat rendering of the side elevation of the final concept. (10 marks)
Evaluation criteria: Scale, proportion, neatness of the sketch and ability to make a rendering
- Draw an interior sketch highlighting design details and material finishes. (10 marks)
Evaluation criteria: Ability to communicate details through sketch and rendering of material finishes.

Mandatory question (Question 6. in the Answer Booklet)

Q.6 Sketching (20 marks)

Draw a perspective view of a kitchen interior with a stove, kitchen utensils (such as pressure cooker, cooking pans, sauce pans etc.), dining utensils (such as ceramic plates, cups, glasses etc.), a wash basin, storage racks with stored cooking ingredients (such as spices in small plastic bottles), fresh cut vegetables kept beside the stove and at least two kitchen gadgets.

Make a **freehand perspective drawing** of this setup, showing all the elements listed above, as seen from the point of view of a 5 ½ feet tall person.

Evaluation criteria:

- a) Quality of composition.
- b) Observation and drawing skills.
- c) Sense of perspective.
- d) Scale and relative proportions.
- e) Use of light, shade and surface finish.

Note:

- Use only pencils.
- Do not use any drawing instrument such as a ruler, compass, set-square etc.
- Do not use any kind of colour.

Mandatory question (Question 7. in the Answer Booklet)

Q.7 Creativity (20 marks)

Imagination is the power of the mind. Some visual elements can come together to create a bigger picture. Observe the visual elements that you see in the boxes provided in your answer booklet.

Complete the visual elements based on your imagination. It may be a character, a product, a landscape, etc. Using the given elements complete the first four frames to reflect what you imagined. Choose ANY THREE ELEMENTS given in the first four frames, and complete the fifth frame. Sketch only within the boundaries of the boxes.

Evaluation criteria: Originality and diversity of your ideas, clarity and neatness of your sketches.
(4 marks for each frame)

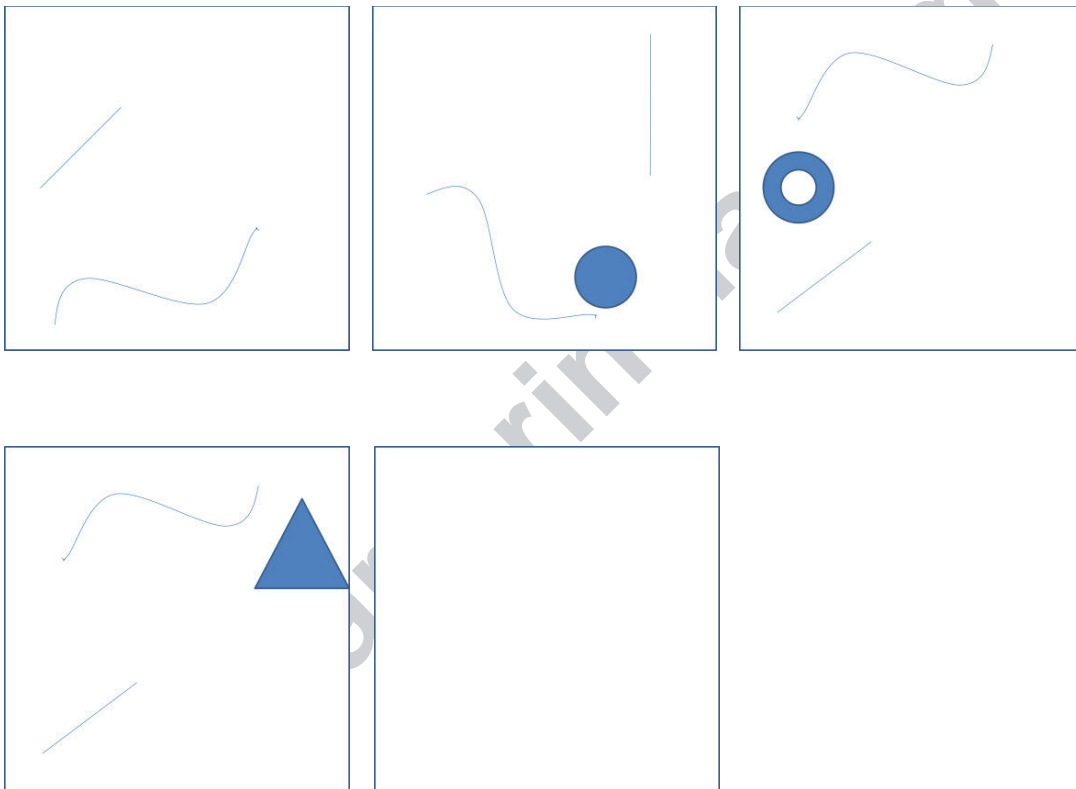

Mandatory question (Question 8. in the Answer Booklet)

Q.8 Visualization (20 marks)

Shown below is a part of a “S shaped motif”. Dotted lines indicate the incomplete part of the motif. Visualize the remaining motif and draw the complete motif with a height of 15 cm. DO NOT draw the dotted lines.

Evaluation criteria:

- Faithful reproduction of the given part of the motif in the required size. (5 Marks)
- Consistency with the existing visual language, harmony, and balance in the imagined part of the motif. (10 Marks)
- Rendering quality of the final form. (5 Marks)

