

2

ಒಟ್ಟು ಮುದ್ರಿತ ಪುಟಗಳ ಸಂಖ್ಯೆ : 16 ]

Total No. of Printed Pages : 16 ]

ಒಟ್ಟು ಪ್ರಶ್ನೆಗಳ ಸಂಖ್ಯೆ : 48 ]

Total No. of Questions : 48 ]

ಸಂಕೇತ ಸಂಖ್ಯೆ : **83-E**

Code No. : **83-E**

**D**

**CCE PR  
UNREVISED  
REDUCED SYLLABUS  
NSR & NSPR**

Question Paper Serial No. **813**

ವಿಷಯ : ವಿಜ್ಞಾನ

**Subject : SCIENCE**

(ಭೌತ ವಿಜ್ಞಾನ, ರಸಾಯನ ವಿಜ್ಞಾನ ಮತ್ತು ಜೀವ ವಿಜ್ಞಾನ / **Physics, Chemistry & Biology**)

( ಇಂಗ್ಲಿಷ್ ಮಾಧ್ಯಮ / **English Medium** )

(ಪುನರಾವರ್ತಿತ ಖಾಸಗಿ ಅಭ್ಯರ್ಥಿ / ಎನ್.ಎಸ್.ಆರ್. & ಎನ್.ಎಸ್.ಪಿ.ಆರ್.)

(**Private Repeater / NSR & NSPR**)

ದಿನಾಂಕ : 13. 06. 2023 ]

[ Date : 13. 06. 2023

ಸಮಯ : ಬೆಳಿಗ್ಗೆ 10-30 ರಿಂದ ಮಧ್ಯಾಹ್ನ-1-45 ರವರೆಗೆ ]

[ Time : 10-30 A.M. to 1-45 P.M.

ಗರಿಷ್ಠ ಅಂಕಗಳು : 100 ]

[ Max. Marks : 100

**General Instructions to the Candidate :**

1. There are *three* parts in the question paper :  
**Part A : Physics, Part B : Chemistry, Part C : Biology.**
2. This question paper consists of objective and subjective types of 48 questions.
3. This question paper has been sealed by reverse jacket. You have to cut on the right side to open the paper at the time of commencement of the examination. Check whether all the pages of the question paper are intact.
4. Follow the instructions given against both the objective and subjective types of questions.
5. Figures in the right hand margin indicate maximum marks for the questions.
6. The maximum time to answer the paper is given at the top of the question paper. It includes 15 minutes for reading the question paper.

**CCE-PR/NSR & NSPR-D(813)4110**

[ Turn over

ಇಲ್ಲಿಂದ ಕತ್ತರಿಸಿ

TEAR HERE TO OPEN THE QUESTION PAPER

ಪ್ರಶ್ನೆಪತ್ರಿಕೆಯನ್ನು ತೆರೆಯಲು ಇಲ್ಲಿ ಕತ್ತರಿಸಿ

Tear here

**PART – A**  
**( PHYSICS )**



I. **Four alternatives are given for each of the following questions / incomplete statements. Choose the correct alternative and write the complete answer along with its letter of alphabet.  $4 \times 1 = 4$**

1. A device that converts electrical energy into mechanical energy

is



- (A) Electric generator (B) Electric motor  
(C) Galvanometer (D) Voltmeter

2. A ray of light travelling in kerosene enters obliquely into water.  
Then that light ray

[ Refractive index of kerosene is 1.44 ]  
[ Refractive index of water is 1.33 ]



- (A) bends towards the normal  
(B) does not bend  
(C) passes through the normal  
(D) bends away from the normal

3. The power plant that generates electricity without using the turbines is

- (A) Thermal power plant (B) Hydro power plant  
(C) Solar power plant (D) Nuclear power plant





4. Imagine, you are holding a straight current carrying conductor as per the right hand thumb rule. If the thumb is upward, then the direction of the field lines of the magnetic field is



- (A) downward (B) upward  
 (C) anti-clockwise (D) clockwise



**II. Answer the following questions :**

**2 × 1 = 2**

5. Draw the symbol diagram of rheostat used in electric circuit.  
 6. Observe the figure and mention the direction of the force acting on the current carrying conductor *AB*. Name the rule that helped you to find the direction of the force.

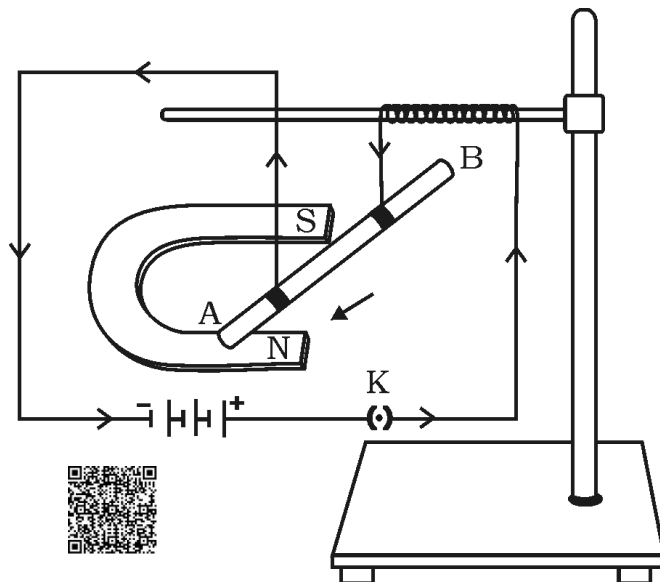



**III. Answer the following questions :**
**5 × 2 = 10**

7. Write any two disadvantages of nuclear energy.
8. 1000 J of heat is produced each 2 seconds in a 5 Ω resistor. Find the potential difference across the resistor.

**OR**

A wire of given material having length 'l' and area of cross-section 'A' has a resistance of '4 Ω'. Find the resistance of another wire of the same material having length  $\frac{l}{2}$  and area of cross-section '2A'.

9. State Ohm's law. Mention any two factors on which the resistance of a conductor depends. 
10. Bio-gas is an excellent fuel. Why ? 
11. The magnification produced by a lens  $m = \frac{1}{3}$ . Then mention the type of the lens and the nature of the image formed.

**IV. Answer the following questions :**
**3 × 3 = 9**

12. Define the following terms related to spherical lens.
  - i) Aperture
  - ii) Centre of curvature 
  - iii) Optical centre.

**OR**

- a) What is meant by power of a lens ? Write the formula used to find the power of a lens. What is the SI unit of power of a lens ?
- b) If the focal lengths of two lenses 'A' and 'B' are + 0.50 m and - 0.40 m respectively, mention the types of these lenses in the same order. 



13. Observe the given diagram :

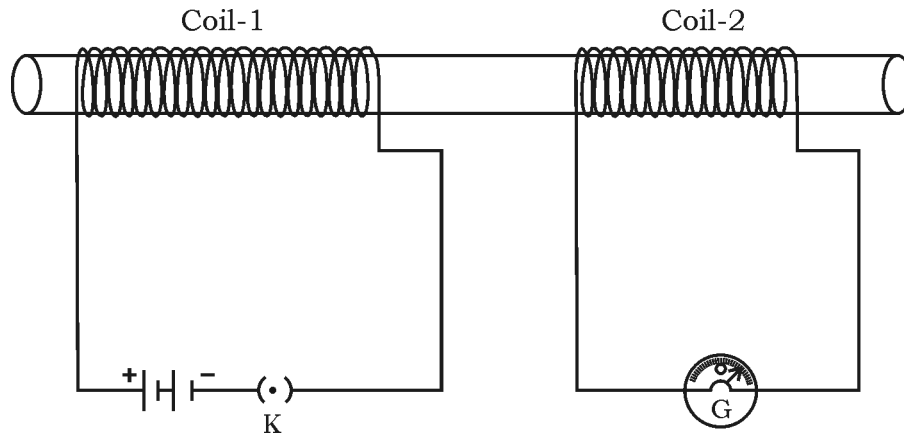

Explain the experiment related to this diagram. What conclusions can be drawn from this experiment ?



14. Draw the ray diagram for the image formation by a convex lens, when the object is placed at  $2F_1$ . With the help of the ray diagram mention the position and the nature of the image formed.

[  $F_1$  : Principal focus of the lens ]



**OR**

Draw the ray diagram for the image formation by a convex lens when the object is placed beyond  $2F_1$ . With the help of the ray diagram mention the position and the nature of the image formed.

[  $F_1$  : Principal focus of the lens ]



**V. Answer the following question :****1 × 4 = 4**

15. a) A bread-toaster rated 350 W is used for 15 hours a day. An electric iron box rated 250 W is used for 5 hours a day. Calculate the cost of using these appliances for 30 days, if the cost of 1 kWh is Rs. 4.



- b) In which method the resistors  $R_1$  and  $R_2$  could be connected so that the equivalent resistance of that electric circuit becomes low ? What is the change in the value of current in the circuit by this type of connection ?

**VI. Answer the following question :****1 × 5 = 5**

16. a) Explain the simple activity to find out the approximate focal length of a convex lens.
- b) What is refraction of light ? State the two laws of refraction of light.



**PART - B**  
**( CHEMISTRY )**



**VII. Four alternatives are given for each of the following questions / incomplete statements. Choose the correct alternative and write the complete answer along with its letter of alphabet.  $2 \times 1 = 2$**

17. Mendeleev's periodic table is constructed on the basis of

(A) Atomic number



(B) Electronic configuration of an atom

(C) Atomic size

(D) Atomic mass

18. A group that has amphoteric oxides among the following is

(A) Sodium oxide and Copper oxide



(B) Aluminium oxide and Zinc oxide

(C) Aluminium oxide and Sodium oxide

(D) Zinc oxide and Copper oxide



**VIII. Answer the following questions :****4 × 1 = 4**

19. Which is the functional group present in 'pentanal' ?
20. Name the ions responsible for acidic and basic nature of the substances.
21. Write the structural formula of cyclohexane.
22. Ionic compounds have high melting point and boiling point. Why ?

**IX. Answer the following questions :****6 × 2 = 12**

23. In a homologous series, the first member of hydrocarbon group has the molecular formula of  $\text{CH}_4$ . Then find out the molecular formula of the fourth member and write two types of structural formula of it.
24. What is malleability ? Name two metals having most malleable property.

**OR**



a) What is sonorous property of metals ?



b) Name two metals that are good conductors of heat.

25. When a piece of metal that was stored in kerosene is put into water, then the evolved gas catches fire and burns.

i) Which is that metal ?



ii) Which gas is evolved ?

iii) Evolved gas catches fire immediately. Why ?

26. Draw the diagram to show the arrangement of the apparatus when acid solution in water conducts electricity.



27. a) Name the acid which causes pain and irritation by ant sting.

b) What is the pH value of acid rain ?



28. What is catenation ? Mention the three types.

**X. Answer the following questions :**



**3 × 3 = 9**

29. Draw the diagram of arrangement of the apparatus used to show the action of steam on metal. Label the following parts :

i) Metal sample



ii) Delivery tube.

30. The elements are arranged in the increasing order of their atomic masses in the table given below. Observe it and answer the following questions :



Sa	Re	Ga	Ma	Pa	Dha	Ni		
H	Li	Be	B	C	N	O	F	Na

i) Name the elements that belong to the same group.

ii) State the law that helps to group these elements.

iii) Write two limitations of the same law.



31. a) Identify unsaturated hydrocarbons in the following carbon compounds and write their structural formula.

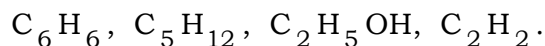

- b) Covalent compounds are generally bad conductors of electricity. Mention the reason.



**OR**

- a) Write electron dot structure of oxygen molecule.
- b) Carbon atom does not form  $C^{4-}$  anion and  $C^{4+}$  cation. Why ?

**XI. Answer the following question :**



**1 × 4 = 4**

32. a) What procedure is to be followed while dissolving a strong acid in water and why ?
- b) A strong solution of sodium hydroxide is added to the strong solution of hydrochloric acid. What is the nature of the salt solution formed here ? Write a balanced chemical equation for this reaction.



**PART - C**  
**( BIOLOGY )**



**XII. Four alternatives are given for each of the following questions / incomplete statements. Choose the correct alternative and write the complete answer along with its letter of alphabet.  $2 \times 1 = 2$**

33. The group that has biodegradable substances only among the following is



- (A) Cowdung, Paper, Rotten fruit  
(B) Paper, Plastic, Leather bag  
(C) Peels of vegetable, Grass, Glass bottle  
(D) Meat, Plastic plate, Paper glass

34. In the given figure of cotyledon, plumule and radicle respectively are,

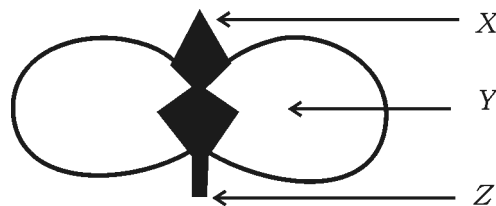

- (A) Z and X  
(B) Y and X  
(C) X and Z  
(D) Z and Y



**XIII. Answer the following questions :****2 × 1 = 2**

35. Name the microbes that break down the organic wastes of the environment.
36. Modern life style is responsible to increase the storage of wastes in the environment. How ?

**XIV. Answer the following questions :****7 × 2 = 14**

37. What is ozone ? Which is the chemical responsible for drop of the amount of ozone ?
38. Draw the diagram showing the structure of nephron and label 'glomerulus'.
39. Student 'A' tells to Student 'B' that the wing of bird and arm of human are analogous organs. Student 'B' replies both of them are homologous organs. Whose answer is correct ? Justify your answer with suitable reasons.
40. What are the differences between blood and lymph ?
41. Draw the diagram showing the germination of pollen on stigma.
42. How is the sex of a child determined in human beings ?
43. a) Which hormone is produced by having iodine rich salt in our diet ? Mention the gland that secretes this hormone.
- b) Which disease is caused due to the deficiency of iodine in our diet ? Write one symptom of this disease.



**XV. Answer the following questions :****3 × 3 = 9**

44. Draw the diagram showing the structure of the human brain and label the following parts :

i) Mid-brain



ii) Pons

45. Round, green colour seeds producing pea plant (  $RR yy$  ) are crossed with wrinkled, yellow colour seeds producing pea plant (  $rr YY$  ). Show the result of  $F_2$  generation with the help of a checker board and mention the ratio of varieties of plants.

**OR**

How are the traits of organisms classified as 'dominant' and 'recessive' traits ? The experiences of an individual acquired during its lifetime cannot be passed on to its progeny. Why ?

46. "Reaching to sexual maturation is an essential event with respect to mammals like humans." Substantiate this statement.

**XVI. Answer the following questions :****2 × 4 = 8**

47. a) As the growth advances in a climbing plant ( creeper ) that appears as the plant is moving towards a particular direction. How ?



b) Explain the necessity of chemical communication in animals.



48. a) Compare the functions of xylem tissue with that of phloem tissue.

b) Explain the strategies of excretion in plants.



**OR**

a) How is the structure of human heart supportive in transporting oxygenated blood and deoxygenated blood ?

Explain.



b) Wall of the ventricles in heart is thick. Why ? How is the blood leakage in the blood vessels prevented ?



**83-E**

16

**CCE PR/NSR & NSPR**

**CCE-PR/NSR & NSPR-D(813)4110**

**2**