

115460033

**NARMADA**

Test Booklet Code

**45**

**ENGLISH**

↑  
Test Booklet No.

Do not open this Test Booklet until you are asked to do so.

This Booklet contains 32 pages, including Rough Page.

**Important Instructions:**

1. The Answer Sheet is inside this Test Booklet. When you are directed to open the Test Booklet, take out the Answer Sheet and fill in the particulars on ORIGINAL Copy carefully with blue/black ball point pen only.
2. The test is of 3 hours duration and the Test Booklet contains 180 multiple-choice questions (four options with a single correct answer) from Physics, Chemistry and Biology (Botany and Zoology).
3. Wherever the symbols/constants are not mentioned, they are to be considered as per their standard meaning/value.
4. Each question carries 4 marks. For each correct response, the candidate will get 4 marks. For each incorrect response, one mark will be deducted from the total scores. The maximum marks are 720.
5. Use Blue/Black Ball Point Pen only for writing particulars on this page/markings responses on Answer Sheet.
6. Rough work is to be done in the space provided for this purpose in the Test Booklet only.
7. On completion of the test, the candidate must hand over the Answer Sheet (ORIGINAL and OFFICE Copy) to the Invigilator before leaving the Room/Hall. The candidates are allowed to take away this Test Booklet with them.
8. The CODE for this Booklet is "45". Make sure to enter this code in the OMR answer sheet.
9. The candidates should ensure that the Answer Sheet is not folded. Do not make any stray marks on the Answer Sheet. Do not write your Roll No. anywhere else except in the specified space in the Test Booklet/ Answer Sheet.
10. Use of white fluid for correction is NOT permissible on the Answer Sheet.
11. Each candidate must show on-demand his/her Admit Card to the Invigilator.
12. No candidate, without special permission of the centre Superintendent or Invigilator, would leave his/her seat.
13. The candidates should not leave the Examination Hall without handing over their Answer Sheet to the Invigilator on duty and sign (with time) the Attendance Sheet twice. Cases, where a candidate has not signed the Attendance Sheet second time, will be deemed not to have handed over the Answer Sheet and dealt with as an Unfair Means case.
14. Use of Electronic/Manual Calculator is prohibited.
15. The candidates are governed by all Rules and Regulations of the examination with regard to the conduct in the Examination Room/Hall. All cases of unfair means will be dealt with as per the Rules and Regulations of this examination along with Public Examinations (Prevention of unfair means act 2024).
16. No part of the Test Booklet and Answer Sheet shall be detached under any circumstances.
17. The candidates will write the Correct Test Booklet Code as given in the Test Booklet/Answer Sheet in the Attendance Sheet.
18. If a candidate marks more than one answers for a question in the OMR Sheet, it will be treated as incorrect and negative marking will be applicable.

Name of the Candidate (in Capitals): UPAMA KAR.

Roll Number : in figures 1702106097.

: in words One million Seven

Centre of Examination (in Capitals): .....

Candidate's Signature : [Signature] Invigilator's Signature : [Signature]

Facsimile signature stamp of Centre Superintendent : [Stamp]

- 1 Consider a water tank shown in the figure. It has one wall at  $x = L$  and can be taken to be very wide in the  $z$  direction. When filled with a liquid of surface tension  $S$  and density  $\rho$ , the liquid surface makes angle  $\theta_0$  ( $\theta_0 \ll 1$ ) with the  $x$ -axis at  $x = L$ . If  $y(x)$  is the height of the surface then the equation for  $y(x)$  is :

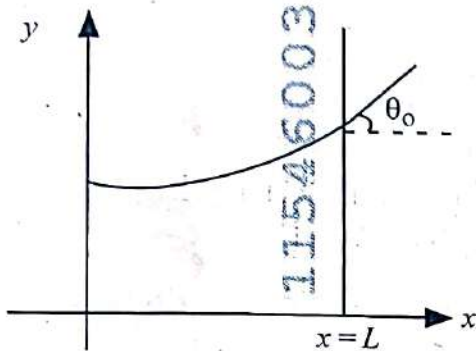

(take  $\theta(x) = \sin \theta(x) = \tan \theta(x) = \frac{dy}{dx}$ ,  $g$  is the acceleration due to gravity)

(1)  $\frac{d^2y}{dx^2} = \frac{\rho g}{S} x$       (2)  $\frac{d^2y}{dx^2} = \frac{\rho g}{S} y$

(3)  $\frac{d^2y}{dx^2} = \sqrt{\frac{\rho g}{S}}$       (4)  $\frac{dy}{dx} = \sqrt{\frac{\rho g}{S}} x$

- 2 A microscope has an objective of focal length 2 cm, eyepiece of focal length 4 cm and the tube length of 40 cm. If the distance of distinct vision of eye is 25 cm, the magnification in the microscope is

- (1) 100      (2) 125  
(3) 150      (4) 250

- 3 An electron (mass  $9 \times 10^{-31}$  kg and charge  $1.6 \times 10^{-19}$  C) moving with speed  $c/100$  ( $c =$  speed of light) is injected into a magnetic field  $\vec{B}$  of magnitude  $9 \times 10^{-4}$  T perpendicular to its direction of motion. We wish to apply a uniform electric field  $\vec{E}$  together with the magnetic field so that the electron does not deflect from its path. Then (speed of light  $c = 3 \times 10^8$  ms $^{-1}$ )

- (1)  $\vec{E}$  is perpendicular to  $\vec{B}$  and its magnitude is  $27 \times 10^4$  V m $^{-1}$   
(2)  $\vec{E}$  is perpendicular to  $\vec{B}$  and its magnitude is  $27 \times 10^2$  V m $^{-1}$   
(3)  $\vec{E}$  is parallel to  $\vec{B}$  and its magnitude is  $27 \times 10^2$  V m $^{-1}$   
(4)  $\vec{E}$  is parallel to  $\vec{B}$  and its magnitude is  $27 \times 10^4$  V m $^{-1}$

- 4 There are two inclined surfaces of equal length ( $L$ ) and same angle of inclination  $45^\circ$  with the horizontal. One of them is rough and the other is perfectly smooth. A given body takes 2 times as much time to slide down on rough surface than on the smooth surface. The coefficient of kinetic friction ( $\mu_k$ ) between the object and the rough surface is close to

- (1) 0.25      (2) 0.40  
(3) 0.5      (4) 0.75

$N = \text{Mis } \theta$

- 5 The kinetic energies of two similar cars A and B are 100 J and 225 J respectively. On applying breaks, car A stops after 1000 m and car B stops after 1500 m. If  $F_A$  and  $F_B$  are the forces applied by the breaks on cars A and B, respectively, then the ratio  $F_A/F_B$  is

- (1)  $\frac{3}{2}$       (2)  $\frac{2}{3}$   
(3)  $\frac{1}{3}$       (4)  $\frac{1}{2}$

- 6 The current passing through the battery in the given circuit, is:

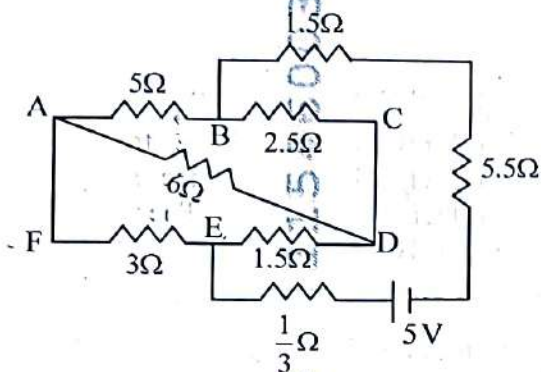

- (1) 2.0 A (2) 0.5 A  
(3) 2.5 A (4) 1.5 A

- 7 A bob of heavy mass  $m$  is suspended by a light string of length  $l$ . The bob is given a horizontal velocity  $v_0$  as shown in figure. If the string gets slack at some point  $P$  making an angle  $\theta$  from the horizontal, the ratio of the speed  $v$  of the bob at point  $P$  to its initial speed  $v_0$  is:

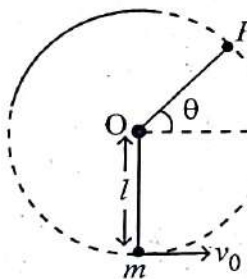

(1)  $(\sin \theta)^{1/2}$

(2)  $\left(\frac{1}{2+3 \sin \theta}\right)^{1/2}$

(3)  $\left(\frac{\cos \theta}{2+3 \sin \theta}\right)^{1/2}$

(4)  $\left(\frac{\sin \theta}{2+3 \sin \theta}\right)^{1/2}$

- 8 The output (Y) of the given logic implementation is similar to the output of an/a \_\_\_\_\_ gate.

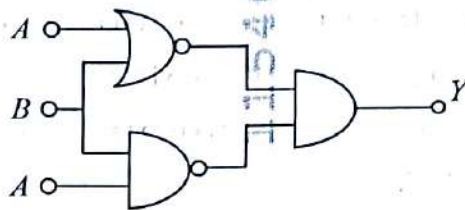

- (1) AND (2) NAND  
(3) OR (4) NOR

- 9 The electric field in a plane electromagnetic wave is given by

$$E_z = 60 \cos (5x + 1.5 \times 10^9 t) \text{ V/m.}$$

Then expression for the corresponding magnetic field is (here subscripts denote the direction of the field) :

(1)  $B_y = 2 \times 10^{-7} \cos (5x + 1.5 \times 10^9 t) T$

(2)  $B_x = 2 \times 10^{-7} \cos (5x + 1.5 \times 10^9 t) T$

(3)  $B_z = 60 \cos (5x + 1.5 \times 10^9 t) T$

(4)  $B_y = 60 \sin (5x + 1.5 \times 10^9 t) T$

- 10 A ball of mass 0.5 kg is dropped from a height of 40 m. The ball hits the ground and rises to a height of 10 m. The impulse imparted to the ball during its collision with the ground is (Take  $g = 9.8 \text{ m/s}^2$ )

- (1) 21 NS (2) 7 NS  
(3) 0 (4) 84 NS

- 11 AB is a part of an electrical circuit (see figure). The potential difference " $V_A - V_B$ ", at the instant when current  $i = 2$  A and is increasing at a rate of 1 amp / second is:

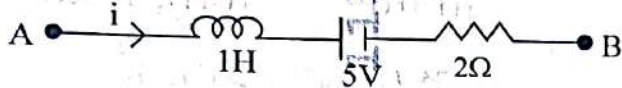

- (1) 5 volt  
 (2) 6 volt  
 (3) 9 volt  
 (4) 10 volt
- 12 A 2 amp current is flowing through two different small circular copper coils having radii ratio 1:2. The ratio of their respective magnetic moments will be
- (1) 1:4                      (2) 1:2  
 (3) 2:1                      (4) 4:1
- 13 In a certain camera, a combination of four similar thin convex lenses are arranged axially in contact. Then the power of the combination and the total magnification in comparison to the power ( $p$ ) and magnification ( $m$ ) for each lens will be, respectively -
- (1)  $4p$  and  $4m$   
 (2)  $p^4$  and  $4m$   
 (3)  $4p$  and  $m^4$   
 (4)  $p^4$  and  $m^4$

- 14 An oxygen cylinder of volume 30 litre has 18.20 moles of oxygen. After some oxygen is withdrawn from the cylinder, its gauge pressure drops to 11 atmospheric pressure at temperature  $27^\circ\text{C}$ . The mass of the oxygen withdrawn from the cylinder is nearly equal to:

[Given,  $R = \frac{100}{12} \text{ J mol}^{-1} \text{ K}^{-1}$ , and

molecular mass of  $\text{O}_2 = 32$ ,

1 atm pressure =  $1.01 \times 10^5 \text{ N/m}^2$ ]

- (1) 0.125 kg                      (2) 0.144 kg  
 (3) 0.116 kg                      (4) 0.156 kg
- 15 In some appropriate units, time ( $t$ ) and position ( $x$ ) relation of a moving particle is given by  $t = x^2 + x$ . The acceleration of the particle is

(1)  $-\frac{2}{(x+2)^3}$                       (2)  $-\frac{2}{(2x+1)^3}$

(3)  $+\frac{2}{(x+1)^3}$                       (4)  $+\frac{2}{2x+1}$

$x^2 = t - x$   
 $x = \sqrt{t - x} \cdot 2x$

- 16 To an ac power supply of 220 V at 50 Hz, a resistor of  $20 \Omega$ , a capacitor of reactance  $25 \Omega$  and an inductor of reactance  $45 \Omega$  are connected in series. The corresponding current in the circuit and the phase angle between the current and the voltage is, respectively -

- (1) 7.8 A and  $30^\circ$   
 (2) 7.8 A and  $45^\circ$   
 (3) 15.6 A and  $30^\circ$   
 (4) 15.6 A and  $45^\circ$

17 The Sun rotates around its centre once in 27 days. What will be the period of revolution if the Sun were to expand to twice its present radius without any external influence? Assume the Sun to be a sphere of uniform density.

- (1) 100 days (2) 105 days  
(3) 115 days (4) 108 days

18 A model for quantized motion of an electron in a uniform magnetic field  $B$  states that the flux passing through the orbit of the electron is  $n(h/e)$  where  $n$  is an integer,  $h$  is Planck's constant and  $e$  is the magnitude of electron's charge. According to the model, the magnetic moment of an electron in its lowest energy state will be ( $m$  is the mass of the electron)

- (1)  $\frac{he}{\pi m}$  (2)  $\frac{he}{2\pi m}$   
(3)  $\frac{heB}{\pi m}$  (4)  $\frac{heB}{2\pi m}$

19 Three identical heat conducting rods are connected in series as shown in the figure. The rods on the sides have thermal conductivity  $2K$  while that in the middle has thermal conductivity  $K$ . The left end of the combination is maintained at temperature  $3T$  and the right end at  $T$ . The rods are thermally insulated from outside. In steady state, temperature at the left junction is  $T_1$  and that at the right junction is  $T_2$ . The ratio  $T_1/T_2$  is

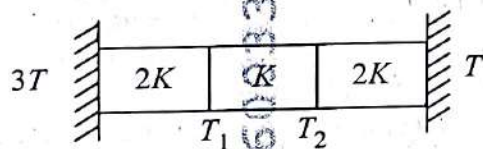

- (1)  $\frac{3}{2}$  (2)  $\frac{4}{3}$   
(3)  $\frac{5}{3}$  (4)  $\frac{5}{4}$

20 The plates of a parallel plate capacitor are separated by  $d$ . Two slabs of different dielectric constant  $K_1$  and  $K_2$  with thickness  $\frac{3}{8}d$  and  $\frac{d}{2}$ , respectively are inserted in the capacitor. Due to this, the capacitance becomes two times larger than when there is nothing between the plates.

If  $K_1 = 1.25 K_2$ , the value of  $K_1$  is :

- (1) 2.66 (2) 2.33  
(3) 1.60 (4) 1.33

$$\frac{K_1}{K_2} = \frac{3 \times \frac{3}{8} \times \frac{d}{2}}{\frac{d}{2} \times \frac{d}{2}}$$

$$= \frac{0.62 \times \frac{3}{2}}{\frac{1}{2}}$$

$$K_1 = 1.25 \times \frac{3}{2} = 1.875$$

21 Two cities X and Y are connected by a regular bus service with a bus leaving in either direction every  $T$  min. A girl is driving scooty with a speed of 60 km/h in the direction X to Y notices that a bus goes past her every 30 minutes in the direction of her motion, and every 10 minutes in the opposite direction. Choose the correct option for the period  $T$  of the bus service and the speed (assumed constant) of the buses.

- (1) 9 min, 40 km/h  
(2) 25 min, 100 km/h  
(3) 10 min, 90 km/h  
(4) 15 min, 120 km/h

22 A uniform rod of mass 20 kg and length 5 m leans against a smooth vertical wall making an angle of  $60^\circ$  with it. The other end rests on a rough horizontal floor. The friction force that the floor exerts on the rod is (take  $g = 10 \text{ m/s}^2$ )

- (1) 100 N  
(2)  $100\sqrt{3}$  N  
(3) 200 N  
(4)  $200\sqrt{3}$  N

- 23 In an oscillating spring mass system, a spring is connected to a box filled with sand. As the box oscillates, sand leaks slowly out of the box vertically so that the average frequency  $\omega(t)$  and average amplitude  $A(t)$  of the system change with time  $t$ . Which one of the following options schematically depicts these changes correctly?

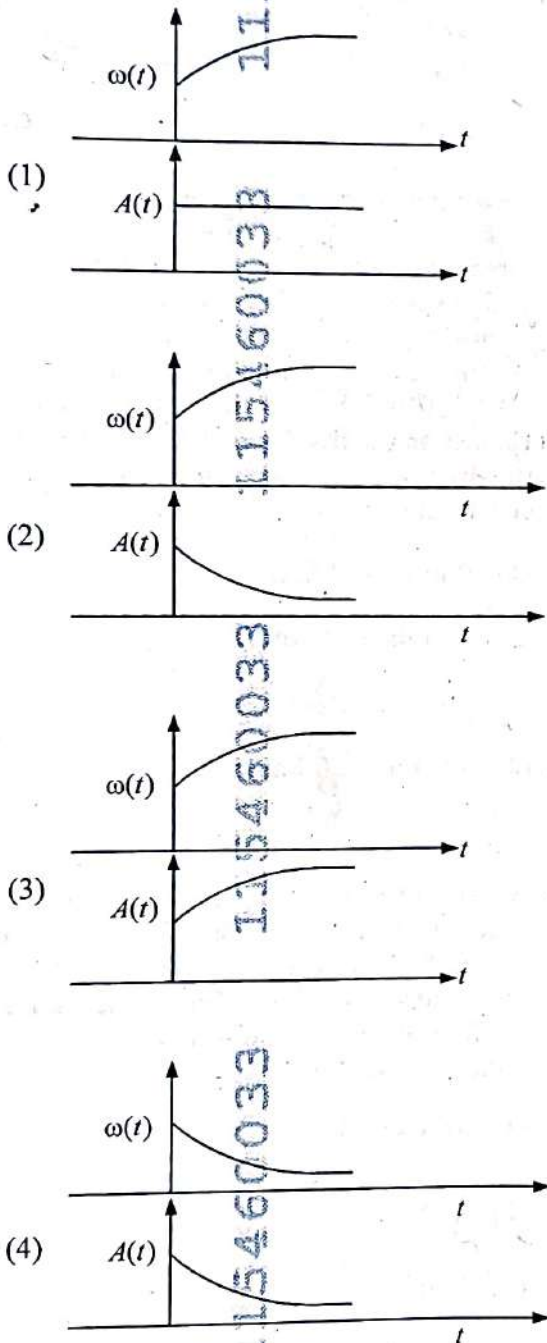

- 24 A balloon is made of a material of surface tension  $S$  and its inflation outlet (from where gas is filled in it) has small area  $A$ . It is filled with a gas of density  $\rho$  and takes a spherical shape of radius  $R$ . When the gas is allowed to flow freely out of it, its radius  $r$  changes from  $R$  to 0 (zero) in time  $T$ . If the speed  $v(r)$  of gas coming out of the balloon depends on  $r$  as  $r^a$  and  $T \propto S^\alpha A^\beta \rho^\gamma R^\delta$  then

- (1)  $a = \frac{1}{2}, \alpha = \frac{1}{2}, \beta = -1, \gamma = +1, \delta = \frac{3}{2}$
- (2)  $a = -\frac{1}{2}, \alpha = -\frac{1}{2}, \beta = -1, \gamma = -\frac{1}{2}, \delta = \frac{5}{2}$
- (3)  $a = -\frac{1}{2}, \alpha = -\frac{1}{2}, \beta = -1, \gamma = \frac{1}{2}, \delta = \frac{7}{2}$
- (4)  $a = \frac{1}{2}, \alpha = \frac{1}{2}, \beta = -\frac{1}{2}, \gamma = \frac{1}{2}, \delta = \frac{7}{2}$

- 25 Consider the diameter of a spherical object being measured with the help of a Vernier callipers. Suppose its 10 Vernier Scale Divisions (V.S.D.) are equal to its 9 Main Scale Divisions (M.S.D.). The least division in the M.S. is 0.1 cm and the zero of V.S. is at  $x = 0.1$  cm when the jaws of Vernier callipers are closed.

If the main scale reading for the diameter is  $M = 5$  cm and the number of coinciding vernier division is 8, the measured diameter after zero error correction, is

- (1) 5.18 cm      (2) 5.08 cm  
(3) 4.98 cm      (4) 5.00 cm

- 26 A parallel plate capacitor made of circular plates is being charged such that the surface charge density on its plates is increasing at a constant rate with time. The magnetic field arising due to displacement current is :

- (1) zero at all places  
(2) constant between the plates and zero outside the plates  
(3) non-zero everywhere with maximum at the imaginary cylindrical surface connecting peripheries of the plates  
(4) zero between the plates and non-zero outside

- 27 An unpolarized light beam travelling in air is incident on a medium of refractive index 1.73 at Brewster's angle. Then-
- (1) reflected light is completely polarized and the angle of reflection is close to  $60^\circ$
  - (2) reflected light is partially polarized and the angle of reflection is close to  $30^\circ$
  - (3) both reflected and transmitted light are perfectly polarized with angles of reflection and refraction close to  $60^\circ$  and  $30^\circ$ , respectively.
  - (4) transmitted light is completely polarized with angle of refraction close to  $30^\circ$
- 28 Two identical charged conducting spheres A and B have their centres separated by a certain distance. Charge on each sphere is  $q$  and the force of repulsion between them is  $F$ . A third identical uncharged conducting sphere is brought in contact with sphere A first and then with B and finally removed from both. New force of repulsion between spheres A and B (Radii of A and B are negligible compared to the distance of separation so that for calculating force between them they can be considered as point charges) is best given as :
- (1)  $\frac{3F}{5}$
  - (2)  $\frac{2F}{3}$
  - (3)  $\frac{F}{2}$
  - (4)  $\frac{3F}{8}$
- 29 A container has two chambers of volumes  $V_1 = 2$  litres and  $V_2 = 3$  litres separated by a partition made of a thermal insulator. The chambers contains  $n_1 = 5$  and  $n_2 = 4$  moles of ideal gas at pressures  $p_1 = 1$  atm and  $p_2 = 2$  atm, respectively. When the partition is removed, the mixture attains an equilibrium pressure of :
- (1) 1.3 atm
  - (2) 1.6 atm
  - (3) 1.4 atm
  - (4) 1.8 atm
- 30 A particle of mass  $m$  is moving around the origin with a constant force  $F$  pulling it towards the origin. If Bohr model is used to describe its motion, the radius  $r$  of the  $n^{\text{th}}$  orbit and the particle's speed  $v$  in the orbit depend on  $n$  as
- (1)  $r \propto n^{1/3}; v \propto n^{1/3}$
  - (2)  $r \propto n^{1/3}; v \propto n^{2/3}$
  - (3)  $r \propto n^{2/3}; v \propto n^{1/3}$
  - (4)  $r \propto n^{4/3}; v \propto n^{-1/3}$
- 31 The radius of Martian orbit around the Sun is about 4 times the radius of the orbit of Mercury. The Martian year is 687 Earth days. Then which of the following is the length of 1 year on Mercury ?
- (1) 88 earth days
  - (2) 225 earth days
  - (3) 172 earth days
  - (4) 124 earth days
- 32 A body weighs 48 N on the surface of the earth. The gravitational force experienced by the body due to the earth at a height equal to one-third the radius of the earth from its surface is :
- (1) 16 N
  - (2) 27 N
  - (3) 32 N
  - (4) 36 N
- 33 A wire of resistance  $R$  is cut into 8 equal pieces. From these pieces two equivalent resistances are made by adding four of these together in parallel. Then these two sets are added in series. The net effective resistance of the combination is :
- (1)  $\frac{R}{64}$
  - (2)  $\frac{R}{32}$
  - (3)  $\frac{R}{16}$
  - (4)  $\frac{R}{8}$

$\frac{3}{4} \times 2 = 1.5$   
 $\frac{0.052}{0.052} = 1$   
 $\frac{0.052}{0.052} = 1$   
 $\frac{0.052}{0.052} = 1$

34 De-Broglie wavelength of an electron orbiting in the  $n = 2$  state of hydrogen atom is close to (Given Bohr radius =  $0.052 \text{ nm}$ )

- (1)  $0.067 \text{ nm}$  (2)  $0.67 \text{ nm}$   
 (3)  $1.67 \text{ nm}$  (4)  $2.67 \text{ nm}$

35 An electric dipole with dipole moment  $5 \times 10^{-6} \text{ Cm}$  is aligned with the direction of a uniform electric field of magnitude  $4 \times 10^5 \text{ N/C}$ . The dipole is then rotated through an angle of  $60^\circ$  with respect to the electric field. The change in the potential energy of the dipole is :

- (1)  $0.8 \text{ J}$  (2)  $1.0 \text{ J}$   
 (3)  $1.2 \text{ J}$  (4)  $1.5 \text{ J}$

36 A constant voltage of  $50 \text{ V}$  is maintained between the points A and B of the circuit shown in the figure. The current through the branch CD of the circuit is :

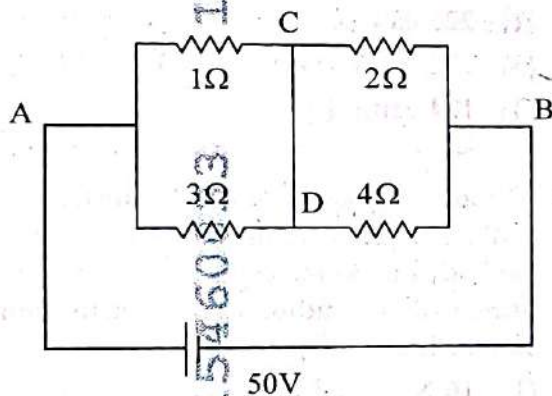

- (1)  $1.5 \text{ A}$  (2)  $2.0 \text{ A}$   
 (3)  $2.5 \text{ A}$  (4)  $3.0 \text{ A}$

37 A photon and an electron (mass  $m$ ) have the same energy  $E$ . The ratio  $(\lambda_{\text{photon}}/\lambda_{\text{electron}})$  of their de Broglie wavelengths is: ( $c$  is the speed of light)

- (1)  $\sqrt{E/2m}$  (2)  $c\sqrt{2mE}$   
 (3)  $c\sqrt{\frac{2m}{E}}$  (4)  $\frac{1}{c}\sqrt{\frac{E}{2m}}$

38 Which of the following options represent the variation of photoelectric current with property of light shown on the x-axis?

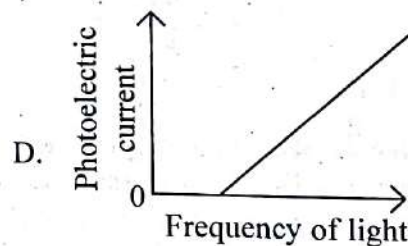
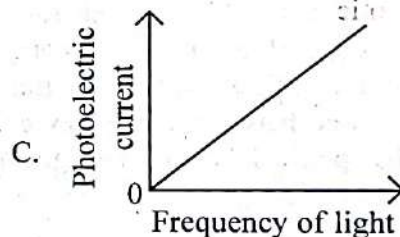
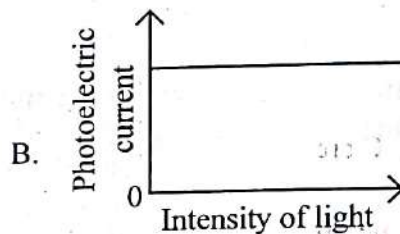
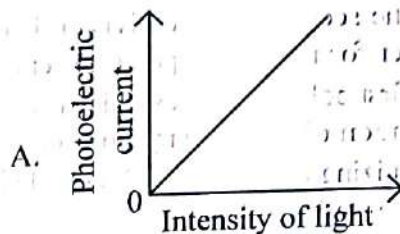

- (1) A only  
 (2) A and C  
 (3) A and D  
 (4) B and D

115460033

[ Contd... ]

45\_English ]

$\frac{M}{MLT^{-2}} \times M = \frac{M^2}{MLT^{-2}} = \frac{L}{T^2}$   
 $\frac{L}{T^2} \times M = \frac{ML}{T^2}$   
 $\frac{L}{T^2} \times M = \frac{ML}{T^2}$   
 $\frac{L}{T^2} \times M = \frac{ML}{T^2}$

8

$\frac{24}{10} = 2.4$   
 $V = IR$   
 $I = \frac{500}{24}$

Visit CollegeDekho

- 39 A sphere of radius  $R$  is cut from a larger solid sphere of radius  $2R$  as shown in the figure. The ratio of the moment of inertia of the smaller sphere to that of the rest part of the sphere about the Y-axis is :

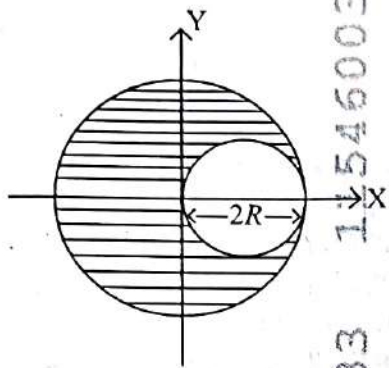

- (1)  $\frac{7}{8}$  (2)  $\frac{7}{40}$   
 (3)  $\frac{7}{57}$  (4)  $\frac{7}{64}$

- 40 A full wave rectifier circuit with diodes ( $D_1$ ) and ( $D_2$ ) is shown in the figure. If input supply voltage  $V_{in} = 220\sin(100\pi t)$  volt, then at  $t = 15 \text{ msec}$

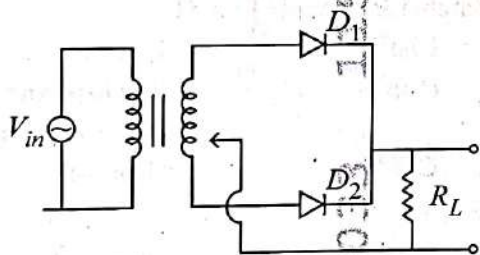

- (1)  $D_1$  is forward biased,  $D_2$  is reverse biased  
 (2)  $D_1$  is reverse biased,  $D_2$  is forward biased  
 (3)  $D_1$  and  $D_2$  both are forward biased  
 (4)  $D_1$  and  $D_2$  both are reverse biased

- 41 Two gases  $A$  and  $B$  are filled at the same pressure in separate cylinders with movable pistons of radius  $r_A$  and  $r_B$ , respectively.

On supplying an equal amount of heat to both the systems reversibly under constant pressure, the pistons of gas  $A$  and  $B$  are displaced by  $16 \text{ cm}$  and  $9 \text{ cm}$ , respectively. If the change in their internal energy is the same, then the ratio

$r_A/r_B$  is equal to

- (1)  $\frac{4}{3}$  (2)  $\frac{3}{4}$   
 (3)  $\frac{2}{\sqrt{3}}$  (4)  $\frac{\sqrt{3}}{2}$

- 42 A physical quantity  $P$  is related to four observations  $a$ ,  $b$ ,  $c$  and  $d$  as follows:

$$P = a^3 b^2 / c \sqrt{d}$$

The percentage errors of measurement in  $a$ ,  $b$ ,  $c$  and  $d$  are 1%, 3%, 2%, and 4% respectively.

The percentage error in the quantity  $P$  is

- (1) 10% (2) 2%  
 (3) 13% (4) 15%

43 The intensity of transmitted light when a polaroid sheet, placed between two crossed polaroids at  $22.5^\circ$  from the polarization axis of one of the polaroid, is ( $I_0$  is the intensity of polarised light after passing through the first polaroid):

(1)  $\frac{I_0}{2}$  (2)  $\frac{I_0}{4}$

(3)  $\frac{I_0}{8}$  (4)  $\frac{I_0}{16}$

44 Two identical point masses P and Q, suspended from two separate massless springs of spring constants  $k_1$  and  $k_2$ , respectively, oscillate vertically. If their maximum speeds are the same, the ratio ( $A_Q/A_P$ ) of the amplitude  $A_Q$  of mass Q to the amplitude  $A_P$  of mass P is:

(1)  $\frac{k_2}{k_1}$  (2)  $\frac{k_1}{k_2}$

(3)  $\sqrt{\frac{k_2}{k_1}}$  (4)  $\sqrt{\frac{k_1}{k_2}}$

45 A pipe open at both ends has a fundamental frequency  $f$  in air. The pipe is now dipped vertically in a water drum to half of its length. The fundamental frequency of the air column is now equal to :

(1)  $\frac{f}{2}$  (2)  $f$

(3)  $\frac{3f}{2}$  (4)  $2f$

46 The ratio of the wavelengths of the light absorbed by a Hydrogen atom when it undergoes  $n=2 \rightarrow n=3$  and  $n=4 \rightarrow n=6$  transitions, respectively, is

(1)  $\frac{1}{36}$  (2)  $\frac{1}{16}$

(3)  $\frac{1}{9}$  (4)  $\frac{1}{4}$

47 Which of the following statements are true?

- A. Unlike Ga that has a very high melting point, Cs has a very low melting point.
- B. On Pauling scale, the electronegativity values of N and Cl are not the same.
- C. Ar,  $K^+$ ,  $Cl^-$ ,  $Ca^{2+}$ , and  $S^{2-}$  are all isoelectronic species.
- D. The correct order of the first ionization enthalpies of Na, Mg, Al, and Si is  $Si > Al > Mg > Na$ .
- E. The atomic radius of Cs is greater than that of Li and Rb.

Choose the correct answer from the options given below :

- (1) A, B, and E only
- (2) C and E only
- (3) C and D only
- (4) A, C, and E only

48 Match List I with List II

List I  
(Ion)

List II  
(Group Number in Cation Analysis)

- |              |               |
|--------------|---------------|
| A. $Co^{2+}$ | I. Group-I    |
| B. $Mg^{2+}$ | II. Group-III |
| C. $Pb^{2+}$ | III. Group-IV |
| D. $Al^{3+}$ | IV. Group-VI  |

Choose the correct answer from the options given below :

- (1) A-III, B-IV, C-II, D-I
- (2) A-III, B-IV, C-I, D-II
- (3) A-III, B-II, C-IV, D-I
- (4) A-III, B-II, C-I, D-IV

- 49 Predict the major product 'P' in the following sequence of reactions -

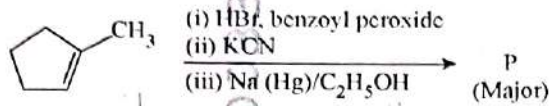

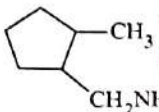
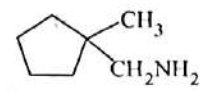
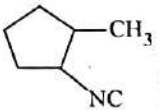
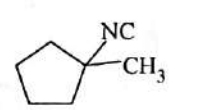
- (1)  (2) 
- (3)  (4) 

- 50 Energy and radius of first Bohr orbit of  $\text{He}^+$  and  $\text{Li}^{2+}$  are

[Given  $R_H = 2.18 \times 10^{-18} \text{ J}$ ,  $a_0 = 52.9 \text{ pm}$ ]

(1)  $E_n(\text{Li}^{2+}) = -19.62 \times 10^{-18} \text{ J}$ ;

$r_n(\text{Li}^{2+}) = 17.6 \text{ pm}$

$E_n(\text{He}^+) = -8.72 \times 10^{-18} \text{ J}$ ;

$r_n(\text{He}^+) = 26.4 \text{ pm}$

(2)  $E_n(\text{Li}^{2+}) = -8.72 \times 10^{-18} \text{ J}$ ;

$r_n(\text{Li}^{2+}) = 26.4 \text{ pm}$

$E_n(\text{He}^+) = -19.62 \times 10^{-18} \text{ J}$ ;

$r_n(\text{He}^+) = 17.6 \text{ pm}$

(3)  $E_n(\text{Li}^{2+}) = -19.62 \times 10^{-16} \text{ J}$ ;

$r_n(\text{Li}^{2+}) = 17.6 \text{ pm}$

$E_n(\text{He}^+) = -8.72 \times 10^{-16} \text{ J}$ ;

$r_n(\text{He}^+) = 26.4 \text{ pm}$

(4)  $E_n(\text{Li}^{2+}) = -8.72 \times 10^{-16} \text{ J}$ ;

$r_n(\text{Li}^{2+}) = 17.6 \text{ pm}$

$E_n(\text{He}^+) = -19.62 \times 10^{-16} \text{ J}$ ;

$r_n(\text{He}^+) = 17.6 \text{ pm}$

- 51 Which of the following are paramagnetic?

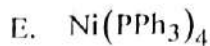
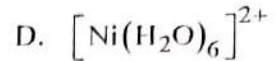
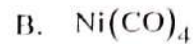

Choose the **correct** answer from the options given below:

(1) A and C only (2) B and E only

(3) A and D only (4) A, D and E only

- 52 Given below are two statements :

**Statement I** : Like nitrogen that can form ammonia, arsenic can form arsine.

**Statement II** : Antimony cannot form antimony pentoxide.

In the light of the above statements, choose the **most appropriate** answer from the options given below :

(1) Both Statement I and Statement II are correct

(2) Both Statement I and Statement II are incorrect

(3) Statement I is correct but Statement II is incorrect

(4) Statement I is incorrect but Statement II is correct

- 53 Which among the following electronic configurations belong to main group elements?

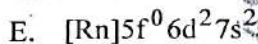
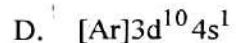
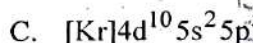
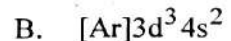
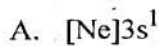

Choose the **correct** answer from the option given below :

(1) B and E only (2) A and C only

(3) D and E only (4) A, C and D only

54 Dalton's Atomic theory could not explain which of the following?

- (1) Law of conservation of mass
- (2) Law of constant proportion
- (3) Law of multiple proportion
- (4) Law of gaseous volume

55 Consider the following compounds :

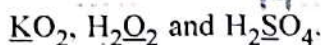

The oxidation states of the underlined elements in them are, respectively,

- (1) +1, -1, and +6
- (2) +2, -2, and +6
- (3) +1, -2, and +4
- (4) +4, -4, and +6

56 If the half-life ( $t_{1/2}$ ) for a first order reaction is 1 minute, then the time required for 99.9% completion of the reaction is closest to :

- (1) 2 minutes
- (2) 4 minutes
- (3) 5 minutes
- (4) 10 minutes

57 The correct order of the wavelength of light absorbed by the following complexes is,

- A.  $[Co(NH_3)_6]^{3+}$     B.  $[Co(CN)_6]^{3-}$   
 C.  $[Cu(H_2O)_4]^{2+}$     D.  $[Ti(H_2O)_6]^{3+}$

Choose the correct answer from the options given below:

- (1)  $B < D < A < C$
- (2)  $B < A < D < C$
- (3)  $C < D < A < B$
- (4)  $C < A < D < B$

58 Which one of the following compounds can exist as cis-trans isomers?

- (1) Pent-1-ene
- (2) 2-Methylhex-2-ene
- (3) 1,1-Dimethylcyclopropane
- (4) 1,2-Dimethylcyclohexane

59 Phosphoric acid ionizes in three steps with their ionization constant values

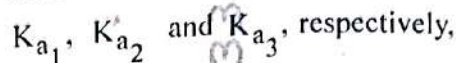

while K is the overall ionization constant.



Which of the following statements are true?

- A.  $\log K = \log K_{a_1} + \log K_{a_2} + \log K_{a_3}$
- B.  $H_3PO_4$  is a stronger acid than  $H_2PO_4^-$  and  $HPO_4^{2-}$ .
- C.  $K_{a_1} > K_{a_2} > K_{a_3}$
- D.  $K_{a_1} = \frac{K_{a_3} + K_{a_2}}{2}$

Choose the correct answer from the options given below:

- (1) A and B only
- (2) A and C only
- (3) B, C and D only
- (4) A, B and C only

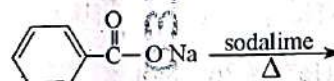
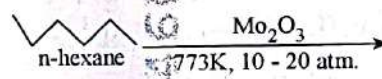
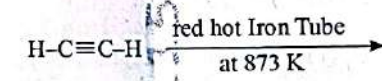
60 Which one of the following reactions does NOT give benzene as the product ?

- (1) 
- (2) 
- (3) 
- (4) 

61 If the molar conductivity ( $\Lambda_m$ ) of a 0.050 mol L<sup>-1</sup> solution of a monobasic weak acid is 90 S cm<sup>2</sup> mol<sup>-1</sup>, its extent (degree) of dissociation will be

[Assume  $\Lambda_+^\circ = 349.6$  S cm<sup>2</sup> mol<sup>-1</sup> and  $\Lambda_-^\circ = 50.4$  S cm<sup>2</sup> mol<sup>-1</sup>.]

- (1) 0.115
- (2) 0.125
- (3) 0.225
- (4) 0.215

$\frac{\Lambda_1}{\Lambda_2} = \frac{\alpha_2}{\alpha_1}$   
 $\frac{1}{\alpha} = \frac{100}{90} \rightarrow \alpha = 0.2$

$\Lambda_m = 349$

62 Given below are two statements :  
**Statement I** : A hypothetical diatomic molecule with bond order zero is quite stable.  
**Statement II** : As bond order increases, the bond length increases.  
 In the light of the above statements, choose the **most appropriate** answer from the options given below :

- (1) Both Statement I and Statement II are true
- (2) Both Statement I and Statement II are false
- (3) Statement I is true but Statement II is false
- (4) Statement I is false but Statement II is true

63 Out of the following complex compounds, which of the compound will be having the minimum conductance in solution?

- (1)  $[\text{Co}(\text{NH}_3)_3\text{Cl}_3]$
- (2)  $[\text{Co}(\text{NH}_3)_4\text{Cl}_2]$
- (3)  $[\text{Co}(\text{NH}_3)_6]\text{Cl}_3$
- (4)  $[\text{Co}(\text{NH}_3)_5\text{Cl}]\text{Cl}$

64 Match List - I with List - II

List-I	List-II
A. $\text{XeO}_3$	I. $sp^3d$ ; linear
B. $\text{XeF}_2$	II. $sp^3$ ; pyramidal
C. $\text{XeOF}_4$	III. $sp^3d^3$ ; distorted octahedral
D. $\text{XeF}_6$	IV. $sp^3d^2$ ; square pyramidal

Choose the **correct** answer from the options given below :

- (1) A-II, B-I, C-IV, D-III
- (2) A-II, B-I, C-III, D-IV
- (3) A-IV, B-II, C-III, D-I
- (4) A-IV, B-II, C-I, D-III

65  $\text{C}(\text{s}) + 2\text{H}_2(\text{g}) \rightarrow \text{CH}_4(\text{g}); \Delta H = -74.8 \text{ kJ mol}^{-1}$   
 Which of the following diagrams gives an accurate representation of the above reaction?  
 [R  $\rightarrow$  reactants; P  $\rightarrow$  products]

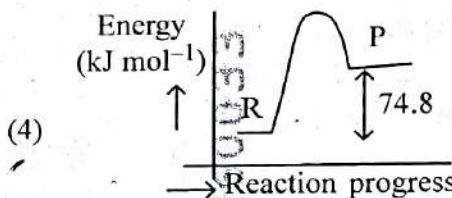
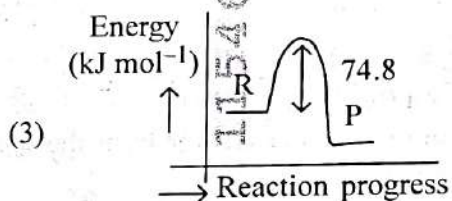
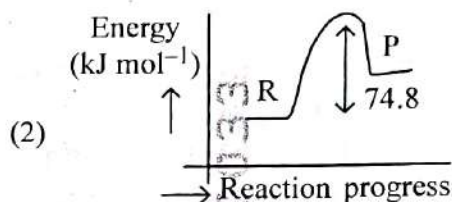
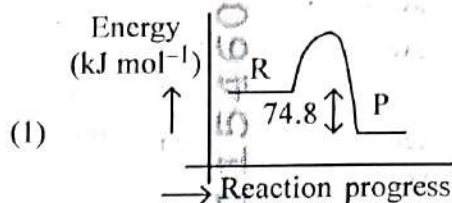

66 Match List - I with List - II

List-I	List-II
(Example)	(Type of Solution)
A. Humidity	I. Solid in solid
B. Alloys	II. Liquid in gas
C. Amalgams	III. Solid in gas
D. Smoke	IV. Liquid in solid

Choose the **correct** answer from the options given below :

- (1) A-II, B-IV, C-I, D-III
- (2) A-II, B-I, C-IV, D-III
- (3) A-III, B-I, C-IV, D-II
- (4) A-III, B-II, C-I, D-IV

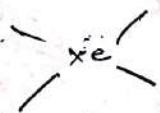

67 The correct order of decreasing basic strength of the given amines is :

- (1) N-methylaniline > benzenamine > ethanamine > N-ethylethanamine
- (2) N-ethylethanamine > ethanamine > benzenamine > N-methylaniline
- (3) N-ethylethanamine > ethanamine > N-methylaniline > benzenamine
- (4) benzenamine > ethanamine > N-methylaniline > N-ethylethanamine

68 Among the following, choose the ones with equal number of atoms.

- A. 212 g of  $\text{Na}_2\text{CO}_3$  (s) [molar mass = 106 g]
- B. 248 g of  $\text{Na}_2\text{O}$  (s) [molar mass = 62 g]
- C. 240 g of  $\text{NaOH}$  (s) [molar mass = 40 g]
- D. 12 g of  $\text{H}_2$  (g) [molar mass = 2 g]
- E. 220 g of  $\text{CO}_2$  (g) [molar mass = 44 g]

Choose the **correct** answer from the options given below :

- (1) A, B, and C only
- (2) A, B, and D only
- (3) B, C, and D only
- (4) B, D, and E only

69 Match List I with List II.

List I (Name of Vitamin)	List II (Deficiency disease)
A. Vitamin B <sub>12</sub>	I. Cheilosis
B. Vitamin D	II. Convulsions
C. Vitamin B <sub>2</sub>	III. Rickets
D. Vitamin B <sub>6</sub>	IV. Pernicious anaemia

Choose the **correct** answer from the options given below :

- (1) A-I, B-III, C-II, D-IV
- (2) A-IV, B-III, C-I, D-II
- (3) A-II, B-III, C-I, D-IV
- (4) A-IV, B-III, C-II, D-I

70 The correct order of decreasing acidity of the following aliphatic acids is :

- (1)  $(\text{CH}_3)_3\text{CCOOH} > (\text{CH}_3)_2\text{CHCOOH} > \text{CH}_3\text{COOH} > \text{HCOOH}$
- (2)  $\text{CH}_3\text{COOH} > (\text{CH}_3)_2\text{CHCOOH} > (\text{CH}_3)_3\text{CCOOH} > \text{HCOOH}$
- (3)  $\text{HCOOH} > \text{CH}_3\text{COOH} > (\text{CH}_3)_2\text{CHCOOH} > (\text{CH}_3)_3\text{CCOOH}$
- (4)  $\text{HCOOH} > (\text{CH}_3)_3\text{CCOOH} > (\text{CH}_3)_2\text{CHCOOH} > \text{CH}_3\text{COOH}$

71 Given below are two statements :

**Statement I :** Ferromagnetism is considered as an extreme form of paramagnetism.

**Statement II :** The number of unpaired electrons in a  $\text{Cr}^{2+}$  ion ( $Z = 24$ ) is the same as that of a  $\text{Nd}^{3+}$  ion ( $Z = 60$ ).

In the light of the above statements, choose the **correct** answer from the options given below :

- (1) Both Statement I and Statement II are true
- (2) Both Statement I and Statement II are false
- (3) Statement I is true but Statement II is false
- (4) Statement I is false but Statement II is true

248  
62

14  
106  
212  
106  
63

1244  
248  
62  
31

6  
248  
126  
6x3

126 x 2 = 12

72 Match List I with List II

List I (Mixture)	List II (Method of Separation)
A. $\text{CHCl}_3 + \text{C}_6\text{H}_5\text{NH}_2$	I. Distillation under reduced pressure
B. Crude oil in petroleum industry	II. Steam distillation
C. Glycerol from spent-lye	III. Fractional distillation
D. Aniline - water	IV. Simple distillation

Choose the correct answer from the options given below :

- (1) A-IV, B-III, C-I, D-II  
 (2) A-IV, B-III, C-II, D-I  
 (3) A-III, B-IV, C-I, D-II  
 (4) A-III, B-IV, C-II, D-I

73 For the reaction  $\text{A}(\text{g}) \rightleftharpoons 2\text{B}(\text{g})$ , the backward reaction rate constant is higher than the forward reaction rate constant by a factor of 2500, at 1000 K.

[Given :  $R = 0.0831 \text{ L atm mol}^{-1} \text{ K}^{-1}$ ]

$K_p$  for the reaction at 1000 K is

- (1) 83.1 (2)  $2.077 \times 10^5$   
 (3) 0.033 (4) 0.021

74 Given below are two statements :

**Statement I :** Benzenediazonium salt is prepared by the reaction of aniline with nitrous acid at 273 - 278 K. It decomposes easily in the dry state.

**Statement II :** Insertion of iodine into the benzene ring is difficult and hence iodobenzene is prepared through the reaction of benzenediazonium salt with KI.

In the light of the above statements, choose the most appropriate answer from the options given below :

- (1) Both Statement I and Statement II are correct  
 (2) Both Statement I and Statement II are incorrect  
 (3) Statement I is correct but Statement II is incorrect  
 (4) Statement I is incorrect but Statement II is correct

75 How many products (including stereoisomers) are expected from monochlorination of the following compound?

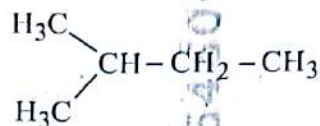

- (1) 2 (2) 3  
 (3) 5 (4) 6

76 Among the given compounds I-III, the correct order of bond dissociation energy of C-H bond marked with \* is :

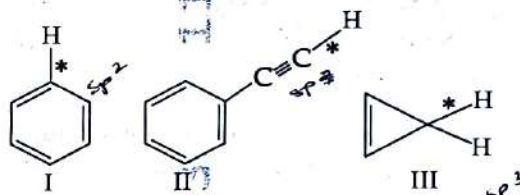

- (1)  $\text{II} > \text{I} > \text{III}$  (2)  $\text{I} > \text{II} > \text{III}$   
 (3)  $\text{III} > \text{II} > \text{I}$  (4)  $\text{II} > \text{III} > \text{I}$

77 Which one of the following compounds **does not** decolourize bromine water?

- (1) (2) (3) (4)

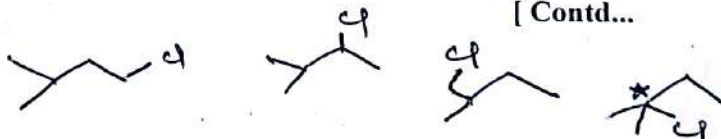

- 78 The major product of the following reaction is :

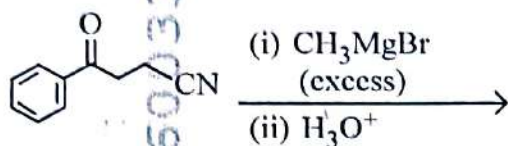

- (1)
- (2)
- (3)
- (4)

- 79 Which of the following aqueous solution will exhibit highest boiling point?

- (1) 0.01M Urea  
 (2) 0.01M  $\text{KNO}_3$   
 (3) 0.01M  $\text{Na}_2\text{SO}_4$   
 (4) 0.015M  $\text{C}_6\text{H}_{12}\text{O}_6$

- 80 Match List - I with List - II

List-I	List-II
A. Haber process	I. Fe catalyst
B. Wacker oxidation	II. $\text{PdCl}_2$
C. Wilkinson catalyst	III. $[(\text{PPh}_3)_3\text{RhCl}]$
D. Ziegler catalyst	IV. $\text{TiCl}_4$ with $\text{Al}(\text{CH}_3)_3$

Choose the correct answer from the options given below:

- (1) A-I, B-II, C-IV, D-III  
 (2) A-II, B-III, C-I, D-IV  
 (3) A-I, B-II, C-III, D-IV  
 (4) A-I, B-IV, C-III, D-II

- 81 5 moles of liquid X and 10 moles of liquid Y make a solution having a vapour pressure of 70 torr. The vapour pressures of pure X and Y are 63 torr and 78 torr respectively. Which of the following is true regarding the described solution?

- (1) The solution shows positive deviation.  
 (2) The solution shows negative deviation.  
 (3) The solution is ideal.  
 (4) The solution has volume greater than the sum of individual volumes.

- 82 Sugar 'X'

- A. is found in honey.  
 B. is a keto sugar.  
 C. exists in  $\alpha$  and  $\beta$  - anomeric forms.  
 D. is laevorotatory.

'X' is :

- (1) D-Glucose      (2) D-Fructose  
 (3) Maltose        (4) Sucrose

- 83 Identify the suitable reagent for the following conversion.

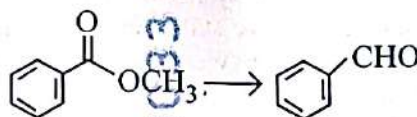

- (1) (i)  $\text{LiAlH}_4$ , (ii)  $\text{H}^+/\text{H}_2\text{O}$   
 (2) (i)  $\text{AlH}(\text{iBu})_2$ , (ii)  $\text{H}_2\text{O}$   
 (3) (i)  $\text{NaBH}_4$ , (ii)  $\text{H}^+/\text{H}_2\text{O}$   
 (4)  $\text{H}_2 / \text{Pd-BaSO}_4$

- 84 Given below are two statements : one is labelled as **Assertion (A)** and the other is labelled as **Reason (R)**.

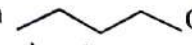
**Assertion (A) :**  I undergoes  $S_N2$  reaction faster than  Cl.

**Reason (R) :** Iodine is a better leaving group because of its large size.

In the light of the above statements, choose the **correct** answer from the options given below :

- (1) Both **A** and **R** are true and **R** is the correct explanation of **A**  
 (2) Both **A** and **R** are true but **R** is not the correct explanation of **A**  
 (3) **A** is true but **R** is false  
 (4) **A** is false but **R** is true

- 85 The standard heat of formation, in kcal/mol of  $Ba^{2+}$  is :

[Given : standard heat of formation of  $SO_4^{2-}$  ion (aq) = -216 kcal/mol, standard heat of crystallisation of

$BaSO_4(s)$  = -4.5 kcal/mol, standard heat of formation of  $BaSO_4(s)$  = -349 kcal/mol]

- (1) -128.5                      (2) -133.0  
 (3) +133.0                      (4) +220.5
- 86 Total number of possible isomers (both structural as well as stereoisomers) of cyclic ethers of molecular formula  $C_4H_8O$  is :
- (1) 6                                      (2) 8  
 (3) 10                                      (4) 11

- 87 Identify the correct orders against the property mentioned

A)  $H_2O > NH_3 > CHCl_3$  - dipole moment

B)  $XeF_4 > XeO_3 > XeF_2$  - number of lone pairs on central atom

C)  $O-H > C-H > N-O$  - bond length

D)  $N_2 > O_2 > H_2$  - bond enthalpy

Choose the **correct** answer from the options given below :

- (1) A, D only                      (2) B, D only  
 (3) A, C only                      (4) B, C only

- 88 Higher yield of NO in

$N_2(g) + O_2(g) \rightleftharpoons 2NO(g)$  can be obtained at

[ $\Delta H$  of the reaction = +180.7 kJ mol<sup>-1</sup>]

- A) higher temperature  
 B) lower temperature  
 C) higher concentration of  $N_2$   
 D) higher concentration of  $O_2$

Choose the **correct** answer from the options given below:

- (1) A, D only                      (2) B, C only  
 (3) B, C, D only                      (4) A, C, D only

- 89 If the rate constant of a reaction is  $0.03 \text{ s}^{-1}$ , how much time does it take for  $7.2 \text{ mol L}^{-1}$  concentration of the reactant to get reduced to  $0.9 \text{ mol L}^{-1}$ ?

[Given:  $\log 2 = 0.301$ ]

- (1) 69.3 s                                      (2) 23.1 s  
 (3) 210 s                                      (4) 21.0 s

$$k = 0.03$$

$$\ln \frac{7.2}{0.9} = kt$$

$$\ln 8 = 0.03t$$

$$2.079 = 0.03t$$

$$t = \frac{2.079}{0.03} = 69.3$$

- 90 Which one of the following reactions does **NOT** belong to "Lassaigne's test"?

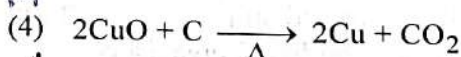
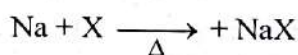
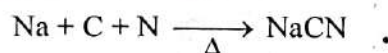

$$BaSO_4 = -349 = Ba^{2+} + SO_4^{2-}$$

$$= Ba^{2+} + (-216)$$

$$\frac{349}{216}$$

- 91 The complex II of mitochondrial electron transport chain is also known as  
 (1) Cytochrome  $bc_1$   
 (2) Succinate dehydrogenase  
 (3) Cytochrome c oxidase  
 (4) NADH dehydrogenase
- 92 Polymerase chain reaction (PCR) amplifies DNA following the equation.  
 (1)  $N^2$  (2)  $2^n$   
 (3)  $2n + 1$  (4)  $2N^2$
- 93 What are the potential drawbacks in adoption of the IVF method?  
 A. High fatality risk to mother  
 B. Expensive instruments and reagents  
 C. Husband/wife necessary for being donors  
 D. Less adoption of orphans  
 E. Not available in India  
 F. Possibility that the early embryo does not survive  
 Choose the correct answer from the options given below :  
 (1) B, D, F only  
 (2) A, C, D, F only  
 (3) A, B, C, D only  
 (4) A, B, C, E, F only
- 94 What is the name of the blood vessel that carries deoxygenated blood from the body to the heart in a frog ?  
 (1) Aorta  
 (2) Pulmonary artery  
 (3) Pulmonary vein  
 (4) Vena cava
- 95 Which one of the following statements refers to Reductionist Biology?  
 (1) Physico-chemical approach to study and understand living organisms.  
 (2) Physiological approach to study and understand living organisms.  
 (3) Chemical approach to study and understand living organisms.  
 (4) Behavioural approach to study and understand living organisms.
- 96 Given below are two statements :  
**Statement I** : In the RNA world, RNA is considered the first genetic material evolved to carry out essential life processes. RNA acts as a genetic material and also as a catalyst for some important biochemical reactions in living systems. Being reactive, RNA is unstable.  
**Statement II** : DNA evolved from RNA and is a more stable genetic material. Its double helical strands being complementary, resist changes by evolving repairing mechanism.  
 In the light of the above statements, choose the **most appropriate** answer from the options given below :  
 (1) Both statement I and statement II are correct  
 (2) Both statement I and statement II are incorrect  
 (3) Statement I is correct but statement II is incorrect  
 (4) Statement I is incorrect but statement II is correct
- 97 Epiphytes that are growing on a mango branch is an example of which of the following?  
 (1) Commensalism  
 (2) Mutualism  
 (3) Predation  
 (4) Amensalism
- 98 From the statements given below choose the correct option :  
 A. The eukaryotic ribosomes are 80S and prokaryotic ribosomes are 70S.  
 B. Each ribosome has two sub-units.  
 C. The two sub-units of 80S ribosome are 60S and 40S while that of 70S are 50S and 30S.  
 D. The two sub-units of 80S ribosome are 60S and 20S and that of 70S are 50S and 20S.  
 E. The two sub-units of 80S are 60S and 30S and that of 70S are 50S and 30S.  
 (1) A, B, C are true  
 (2) A, B, D are true  
 (3) A, B, E are true  
 (4) B, D, E are true

99 Which one of the following is an example of ex-situ conservation?

- (1) National Park
- (2) Wildlife Sanctuary
- (3) Zoos and botanical gardens
- (4) Protected areas

100 Given below are two statements :

**Statement I** : The primary source of energy in an ecosystem is solar energy.

**Statement II** : The rate of production of organic matter during photosynthesis in an ecosystem is called net primary productivity (NPP).

In the light of the above statements, choose the most appropriate answer from the options given below :

- (1) Both statement I and statement II are correct
- (2) Both statement I and statement II are incorrect
- (3) Statement I is correct but statement II is incorrect
- (4) Statement I is incorrect but statement II is correct

101 Match List - I with List - II.

**List - I**

**List - II**

- |                       |  |
|-----------------------|--|
| A. Emphysema          | I. Rapid spasms in muscle due to low $Ca^{++}$ in body fluid             |
| B. Angina Pectoris    | II. Damaged alveolar walls and decreased respiratory surface             |
| C. Glomerulonephritis | III. Acute chest pain when not enough oxygen is reaching to heart muscle |
| D. Tetany             | IV. Inflammation of glomeruli of kidney                                  |

Choose the correct answer from the options given below :

- (1) A-III, B-I, C-IV, D-II
- (2) A-III, B-I, C-II, D-IV
- (3) A-II, B-IV, C-III, D-I
- (4) A-II, B-III, C-IV, D-I

102 Given below are two statements : One is labelled as **Assertion (A)** and the other is labelled as **Reason (R)**.

**Assertion (A)** : Both wind and water pollinated flowers are not very colourful and do not produce nectar.

**Reason (R)** : The flowers produce enormous amount of pollen grains in wind and water pollinated flowers.

In the light of the above statements, choose the correct answer from the options given below :

- (1) Both **A** and **R** are true and **R** is the correct explanation of **A**
- (2) Both **A** and **R** are true but **R** is NOT the correct explanation of **A**
- (3) **A** is true but **R** is false
- (4) **A** is false but **R** is true

103 Which of the following is an example of non-distilled alcoholic beverage produced by yeast?

- (1) Whisky
- (2) Brandy
- (3) Beer
- (4) Rum

104 Given below are two statements :

**Statement I** : In a floral formula  $\oplus$  stands for zygomorphic nature of the flower, and  $\underline{G}$  stands for inferior ovary.

**Statement II** : In a floral formula  $\oplus$  stands for actinomorphic nature of the flower and  $\underline{G}$  stands for superior ovary.

In the light of the above statements, choose the correct answer from the options given below :

- (1) Both Statement I and Statement II are correct
- (2) Both Statement I and Statement II are incorrect
- (3) Statement I is correct but Statement II is incorrect
- (4) Statement I is incorrect but Statement II is correct

105 Streptokinase produced by *bacterium Streptococcus* is used for

- (1) Curd production
- (2) Ethanol production
- (3) Liver disease treatment
- (4) Removing clots from blood vessels

106 Which chromosome in the human genome has the highest number of genes?

- (1) Chromosome X
- (2) Chromosome Y
- (3) Chromosome 1
- (4) Chromosome 10

107 Which of the following statement is **correct** about location of the male frog copulatory pad ?

- (1) First and Second digit of fore limb
- (2) First digit of hind limb
- (3) Second digit of fore limb
- (4) First digit of the fore limb

108 Which one of the following phytohormones promotes nutrient mobilization which helps in the delay of leaf senescence in plants?

- (1) Ethylene
- (2) Abscisic acid
- (3) Gibberellin
- (4) Cytokinin

109 While trying to find out the characteristic of a newly found animal, a researcher did the histology of adult animal and observed a cavity with presence of mesodermal tissue towards the body wall but no mesodermal tissue was observed towards the alimentary canal. What could be the possible coelome of that animal ?

- (1) Acoelomate
- (2) Pseudocoelomate
- (3) Schizocoelomate
- (4) Spongocoelomate

110 Match List - I with List - II.

- | List - I        | List - II            |
|-----------------|----------------------|
| A. Head         | I. Enzymes           |
| B. Middle piece | II. Sperm motility   |
| C. Acrosome     | III. Energy          |
| D. Tail         | IV. Genetic material |

Choose the **correct** answer from the options given below :

- (1) A-IV, B-III, C-I, D-II
- (2) A-IV, B-III, C-II, D-I
- (3) A-III, B-IV, C-II, D-I
- (4) A-III, B-II, C-I, D-IV

111 Given below are the stages in the life cycle of pteridophytes. Arrange the following stages in the correct sequence.

- A. Prothallus stage
- B. Meiosis in spore mother cells
- C. Fertilisation
- D. Formation of archegonia and antheridia in gametophyte.
- E. Transfer of antherozoids to the archegonia in presence of water.

Choose the **correct** answer from the options given below :

- (1) B, A, D, E, C
- (2) B, A, E, C, D
- (3) D, E, C, A, B
- (4) E, D, C, B, A

112 Cardiac activities of the heart are regulated by :

- A. Nodal tissue
- B. A special neural centre in the medulla oblongata
- C. Adrenal medullary hormones
- D. Adrenal cortical hormones

Choose the **correct** answer from the options given below :

- (1) A, B and C Only
- (2) A, B, C and D
- (3) A, C and D Only
- (4) A, B and D Only

113 Which of following organisms *cannot* fix nitrogen?

- A. *Azotobacter*      B. *Oscillatoria*  
 C. *Anabaena*        D. *Volvox*  
 E. *Nostoc*

Choose the **correct** answer from the options given below:

- (1) A only                (2) D only  
 (3) B only                (4) E only

114 Given below are two statements :

**Statement I** : Transfer RNAs and ribosomal RNA do not interact with mRNA.

**Statement II** : RNA interference (RNAi) takes place in all eukaryotic organisms as a method of cellular defence.

In the light of the above statements, choose the **most appropriate** answer from the options given below :

- (1) Both Statement I and Statement II are correct  
 (2) Both Statement I and Statement II are incorrect  
 (3) Statement I is correct but Statement II is incorrect  
 (4) Statement I is incorrect but Statement II is correct

115

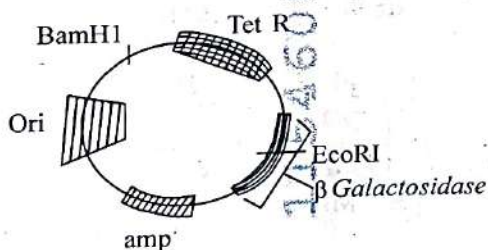

In the above represented plasmid an alien piece of DNA is inserted at EcoRI site. Which of the following strategies will be chosen to select the recombinant colonies?

- (1) Using ampicillin & tetracyclin containing medium plate.  
 (2) Blue color colonies will be selected.  
 (3) White color colonies will be selected.  
 (4) Blue color colonies grown on ampicillin plates can be selected.

116 Which of the following genetically engineered organisms was used by Eli Lilly to prepare human insulin?

- (1) Bacterium            (2) Yeast  
 (3) Virus                 (4) Phage

117 Name the class of enzyme that usually catalyze the following reaction:



Where, G  $\rightarrow$  a group other than hydrogen

S  $\rightarrow$  a substrate

S<sup>#</sup>  $\rightarrow$  another substrate

- (1) Hydrolase            (2) Lyase  
 (3) Transferase        (4) Ligase

118 Find the statement that is **NOT** correct with regard to the structure of monocot stem.

- (1) Hypodermis is parenchymatous.  
 (2) Vascular bundles are scattered.  
 (3) Vascular bundles are conjoint and closed.  
 (4) Phloem parenchyma is absent.

119 The correct sequence of events in the life cycle of bryophytes is

- A. Fusion of antherozoid with egg.  
 B. Attachment of gametophyte to substratum.  
 C. Reduction division to produce haploid spores.  
 D. Formation of sporophyte.  
 E. Release of antherozoids into water.

Choose the **correct** answer from the options given below :

- (1) D, E, A, C, B  
 (2) B, E, A, C, D  
 (3) B, E, A, D, C  
 (4) D, E, A, B, C

120 Which are correct:

- A. Computed tomography and magnetic resonance imaging detect cancers of internal organs.
- B. Chemotherapeutic drugs are used to kill non-cancerous cells.
- C.  $\alpha$ -interferon activate the cancer patients' immune system and helps in destroying the tumour.
- D. Chemotherapeutic drugs are biological response modifiers.
- E. In the case of leukaemia blood cell counts are decreased.

Choose the **correct** answer from the options given below:

- (1) B and D only (2) D and E only  
(3) C and D only (4) A and C only

121 Match List - I with List - II.

List - I	List - II
A. Centromere	I. Mitochondrion
B. Cilium	II. Cell division
C. Cristae	III. Cell movement
D. Cell membrane	IV. Phospholipid Bilayer

Choose the **correct** answer from the options given below :

- (1) A-I, B-II, C-III, D-IV  
(2) A-II, B-I, C-IV, D-III  
(3) A-IV, B-II, C-III, D-I  
(4) A-II, B-III, C-I, D-IV

122 Match List I with List II :

List I	List II
A. Chlorophyll a	I. Yellow-green
B. Chlorophyll b	II. Yellow
C. Xanthophylls	III. Blue-green
D. Carotenoids	IV. Yellow to Yellow-orange

Choose the option with all **correct** matches.

- (1) A-III, B-IV, C-II, D-I  
(2) A-III, B-I, C-II, D-IV  
(3) A-I, B-II, C-IV, D-III  
(4) A-I, B-IV, C-III, D-II

123 Find the correct statements :

- A. In human pregnancy, the major organ systems are formed at the end of 12 weeks.
- B. In human pregnancy the major organ systems are formed at the end of 8 weeks.
- C. In human pregnancy heart is formed after one month of gestation.
- D. In human pregnancy, limbs and digits develop by the end of second month.
- E. In human pregnancy the appearance of hair is usually observed in the fifth month.

Choose the **correct** answer from the options given below :

- (1) A and E Only  
(2) B and C Only  
(3) B, C, D and E Only  
(4) A, C, D and E Only

124 In the seeds of cereals, the outer covering of endosperm separates the embryo by a protein-rich layer called :

- (1) Coleoptile (2) Coleorhiza  
(3) Integument (4) Aleurone layer

125 Which of the following diagrams is correct with regard to the proximal (P) and distal (D) tubule of the Nephron.

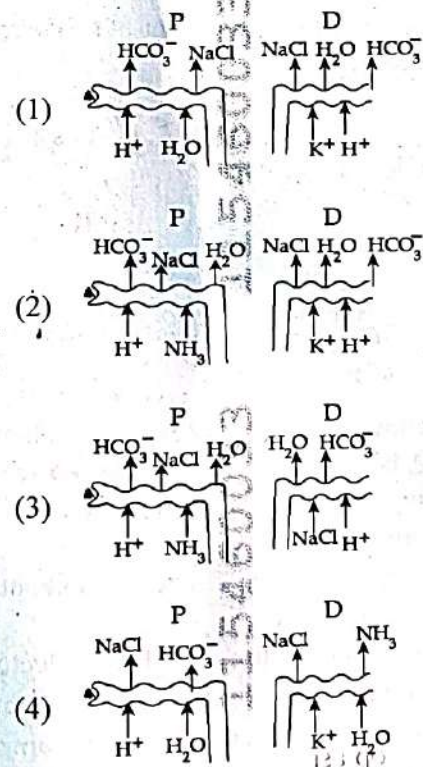

- 126 Identify the part of a bio-reactor which is used as a foam breaker from the given figure.

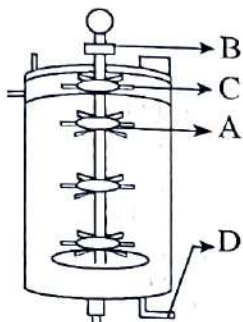

- (1) A                      (2) B  
(3) D                      (4) C

- 127 Given below are two statements : One is labelled as Assertion (A) and the other is labelled as Reason (R)

**Assertion (A) :** A typical unfertilised, angiosperm embryo sac at maturity is 8 nucleate and 7-celled.

**Reason (R) :** The egg apparatus has 2 polar nuclei.

In the light of the above statements, choose the correct answer from the options given below :

- (1) Both A and R are true and R is the correct explanation of A  
(2) Both A and R are true but R is NOT the correct explanation of A  
(3) A is true but R is false  
(4) A is false but R is true

- 128 A specialised membranous structure in a prokaryotic cell which helps in cell wall formation, DNA replication and respiration is :

- (1) Mesosome  
(2) Chromatophores  
(3) Cristae  
(4) Endoplasmic Reticulum

- 129 Which of the following are the post-transcriptional events in an eukaryotic cell?

- A. Transport of pre-mRNA to cytoplasm prior to splicing.  
B. Removal of introns and joining of exons.  
C. Addition of methyl group at 5' end of hnRNA.  
D. Addition of adenine residues at 3' end of hnRNA.  
E. Base pairing of two complementary RNAs.

Choose the correct answer from the options given below :

- (1) A, B, C only  
(2) B, C, D only  
(3) B, C, E only  
(4) C, D, E only

- 130 What is the pattern of inheritance for polygenic trait?

- (1) Mendelian inheritance pattern  
(2) Non-mendelian inheritance pattern  
(3) Autosomal dominant pattern  
(4) X-linked recessive inheritance pattern

- 131 Which one of the following enzymes contains 'Haem' as the prosthetic group?

- (1) RuBisCo  
(2) Carbonic anhydrase  
(3) Succinate dehydrogenase  
(4) Catalase

132 Each of the following characteristics represent a Kingdom proposed by Whittaker. Arrange the following in increasing order of complexity of body organization.

- A. Multicellular heterotrophs with cell wall made of chitin.
- B. Heterotrophs with tissue/organ/organ system level of body organization.
- C. Prokaryotes with cell wall made of polysaccharides and amino acids.
- D. Eukaryotic autotrophs with tissue/organ level of body organization.
- E. Eukaryotes with cellular body organization.

Choose the **correct** answer from the options given below :

- (1) A, C, E, B, D    (2) C, E, A, D, B  
 (3) A, C, E, D, B    (4) C, E, A, B, D

133 Who is known as the father of Ecology in India?

- (1) S. R. Kashyap    (2) Ramdeo Misra  
 (3) Ram Udar        (4) Birbal Sahni

134 Match List I with List II :

List-I	List-II
A. Alfred Hershey and Martha Chase	I. Streptococcus pneumoniae
B. Euchromatin	II. Densely packed and dark-stained
C. Frederick Griffith	III. Loosely packed and light-stained
D. Heterochromatin	IV. DNA as genetic material confirmation

Choose the **correct** answer from the options given below :

- (1) A-II, B-IV, C-I, D-III  
 (2) A-IV, B-II, C-I, D-III  
 (3) A-IV, B-III, C-I, D-II  
 (4) A-III, B-II, C-IV, D-I

135 Neoplastic characteristics of cells refer to :

- A. A mass of proliferating cell
- B. Rapid growth of cells
- C. Invasion and damage to the surrounding tissue
- D. Those confined to original location

Choose the **correct** answer from the options given below:

- (1) A, B only        (2) A, B, C only  
 (3) A, B, D only    (4) B, C, D only

136 Given below are two statements :

**Statement I :** The DNA fragments extracted from gel electrophoresis can be used in construction of recombinant DNA.

**Statement II :** Smaller size DNA fragments are observed near anode while larger fragments are found near the wells in an agarose gel.

In the light of the above statements, choose the **most appropriate** answer from the options given below :

- (1) Both statement I and statement II are correct
- (2) Both statement I and statement-II are incorrect
- (3) Statement I is correct but statement II is incorrect
- (4) Statement I is incorrect but statement II is correct

137 Match List I with List II.

List I	List II
A. Adenosine	I. Nitrogen base
B. Adenylic acid	II. Nucleotide
C. Adenine	III. Nucleoside
D. Alanine	IV. Amino acid

Choose the option with all **correct** matches.

- (1) A-III, B-IV, C-II, D-I  
 (2) A-III, B-II, C-IV, D-I  
 (3) A-III, B-II, C-I, D-IV  
 (4) A-II, B-III, C-I, D-IV

- 138 Consider the following :
- The reductive division for the human female gametogenesis starts earlier than that of the male gametogenesis.
  - The gap between the first meiotic division and the second meiotic division is much shorter for males compared to females.
  - The first polar body is associated with the formation of the primary oocyte.
  - Luteinizing Hormone (LH) surge leads to disintegration of the endometrium and onset of menstrual bleeding.

Choose the **correct** answer from the options given below :

- A and B are true
- A and C are true
- B and D are true
- B and C are true

- 139 All living members of the class Cyclostomata are:

- Free living
- Endoparasite
- Symbiotic
- Ectoparasite

- 140 Given below are two statements : one is labelled as **Assertion (A)** and the other is labelled as **Reason (R)**.

**Assertion (A)** : The primary function of the Golgi apparatus is to package the materials made by the endoplasmic reticulum and deliver it to intracellular targets and outside the cell.

**Reason (R)** : Vesicles containing materials made by the endoplasmic reticulum fuse with the cis face of the Golgi apparatus, and they are modified and released from the trans face of the Golgi apparatus.

In the light of the above statements, choose the **correct** answer from the options given below :

- Both A and R are true and R is the correct explanation of A
- Both A and R are true but R is not the correct explanation of A
- A is true but R is false
- A is false but R is true

- 141 Match List I with List II :

List I	List II
A. Scutellum	I. Persistent nucellus
B. Non-albuminous seed	II. Cotyledon of Monocot seed
C. Epiblast	III. Groundnut
D. Perisperm	IV. Rudimentary cotyledon

Choose the option with all **correct** matches.

- A-II, B-III, C-IV, D-I
- A-IV, B-III, C-II, D-I
- A-IV, B-III, C-I, D-II
- A-II, B-IV, C-III, D-I

- 142 Given below are two statements : one is labelled as **Assertion (A)** and the other is labelled as **Reason (R)**.

**Assertion (A)** : All vertebrates are chordates but all chordates are not vertebrate.

**Reason (R)** : The members of subphylum vertebrata possess notochord during the embryonic period, the notochord is replaced by a cartilaginous or bony vertebral column in adults.

In the light of the above statements, choose the **correct** answer from the options given below :

- Both A and R are true and R is the correct explanation of A
- Both A and R are true but R is not the correct explanation of A
- A is true but R is false
- A is false but R is true

- 143 Identify the statement that is **NOT** correct.

- Each antibody has two light and two heavy chains.
- The heavy and light chains are held together by disulfide bonds.
- Antigen binding site is located at C-terminal region of antibody molecules.
- Constant region of heavy and light chains are located at C-terminus of antibody molecules.

144 Silencing of specific mRNA is possible via RNAi because of -

- (1) Complementary dsRNA
- (2) Inhibitory ssRNA
- (3) Complementary tRNA
- (4) Non-complementary ssRNA

145 Genes R and Y follow independent assortment. If RRYYY produce round yellow seeds and rryy produce wrinkled green seeds, what will be the phenotypic ratio of the F<sub>2</sub> generation?

- (1) Phenotypic ratio - 1 : 2 : 1
- (2) Phenotypic ratio - 3 : 1
- (3) Phenotypic ratio - 9 : 3 : 3 : 1
- (4) Phenotypic ratio - 9 : 7

146 Histones are enriched with -

- (1) Lysine & Arginine
- (2) Leucine & Lysine
- (3) Phenylalanine & Leucine
- (4) Phenylalanine & Arginine

147 The first menstruation is called :

- (1) Menopause
- (2) Menarche
- (3) Diapause
- (4) Ovulation

148 Match List - I with List - II.

- | List - I                   | List - II                      |
|----------------------------|--------------------------------|
| A. Heart                   | I. Erythropoietin              |
| B. Kidney                  | II. Aldosterone                |
| C. Gastro-intestinal tract | III. Atrial natriuretic factor |
| D. Adrenal Cortex          | IV. Secretin                   |

Choose the correct answer from the options given below :

- (1) A-II, B-I, C-III, D-IV
- (2) A-IV, B-III, C-II, D-I
- (3) A-I, B-III, C-IV, D-II
- (4) A-III, B-I, C-IV, D-II

149 The protein portion of an enzyme is called :

- (1) Cofactor
- (2) Coenzyme
- (3) Apoenzyme
- (4) Prosthetic group

150 Which of the following is the unit of productivity of an Ecosystem?

- (1) gm<sup>-2</sup>
- (2) KCal m<sup>-2</sup>
- (3) KCal m<sup>-3</sup>
- (4) (KCal m<sup>-2</sup>)yr<sup>-1</sup>

151 Sweet potato and potato represent a certain type of evolution. Select the correct combination of terms to explain the evolution.

- (1) Analogy, convergent
- (2) Homology, divergent
- (3) Homology, convergent
- (4) Analogy, divergent

152 With the help of given pedigree, find out the probability for the birth of a child having no disease and being a carrier (has the disease mutation in one allele of the gene) in F<sub>3</sub> generation.

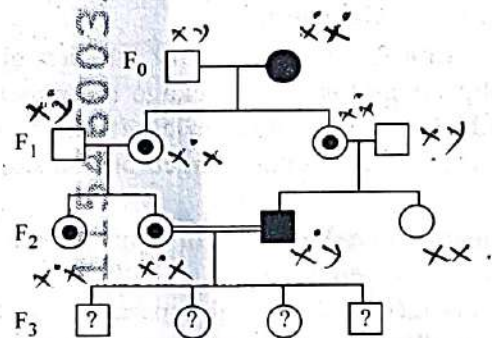

- Unaffected male
- Affected male
- Carrier female
- Unaffected female
- Affected female

- (1) 1/4
- (2) 1/2
- (3) 1/8
- (4) Zero



- 153 Given below are two statements : One is labelled as **Assertion (A)** and the other is labelled as **Reason (R)**.

**Assertion (A)** : Cells of the tapetum possess dense cytoplasm and generally have more than one nucleus.

**Reason (R)** : Presence of more than one nucleus in the tapetum increases the efficiency of nourishing the developing microspore mother cells.

In light of the above statements, choose the **most appropriate** answer from the options given below :

- (1) Both **A** and **R** are true and **R** is the correct explanation of **A**
- (2) Both **A** and **R** are true but **R** is **NOT** the correct explanation of **A**
- (3) **A** is true but **R** is false
- (4) **A** is false but **R** is true

- 154 How many meiotic and mitotic divisions need to occur for the development of a mature female gametophyte from the megaspore mother cell in an angiosperm plant?

- (1) 2 Meiosis and 3 Mitosis
- (2) 1 Meiosis and 2 Mitosis
- (3) 1 Meiosis and 3 Mitosis
- (4) No Meiosis and 2 Mitosis

- 155 Which of the following is an example of a zygomorphic flower?

- (1) Petunia
- (2) Datura
- (3) Pea
- (4) Chilli

- 156 After maturation, in primary lymphoid organs, the lymphocytes migrate for interaction with antigens to secondary lymphoid organ(s) / tissue(s) like:

- A. thymus
- B. bone marrow
- C. spleen
- D. lymph nodes
- E. Peyer's patches

Choose the **correct** answer from the options given below:

- (1) B, C, D only
- (2) A, B, C only
- (3) E, A, B only
- (4) C, D, E only

- 157 Given below are two statements :

**Statement I** : Fig fruit is a non-vegetarian fruit as it has enclosed fig wasps in it.

**Statement II** : Fig wasp and fig tree exhibit mutual relationship as fig wasp completes its life cycle in fig fruit and fig fruit gets pollinated by fig wasp.

In the light of the above statements, choose the **most appropriate** answer from the options given below :

- (1) Both statement I and statement II are correct
- (2) Both statement I and statement II are incorrect
- (3) Statement I is correct but statement II is incorrect
- (4) Statement I is incorrect but statement II is correct

- 158 What is the main function of the spindle fibers during mitosis ?

- (1) To separate the chromosomes
- (2) To synthesize new DNA
- (3) To repair damaged DNA
- (4) To regulate cell growth

- 159 Which one of the following is the characteristic feature of gymnosperms?

- (1) Seeds are enclosed in fruits.
- (2) Seeds are naked.
- (3) Seeds are absent.
- (4) Gymnosperms have flowers for reproduction.

160 Consider the following statements regarding function of adrenal medullary hormones :

- A. It causes pupillary constriction
- B. It is a hyperglycemic hormone
- C. It causes piloerection
- D. It increases strength of heart contraction

Choose the **correct** answer from the options given below :

- (1) C and D Only
- (2) B, C and D Only
- (3) A, C and D Only
- (4) D Only

161 Why can't insulin be given orally to diabetic patients?

- (1) Human body will elicit strong immune response
- (2) It will be digested in Gastro-Intestinal (GI) tract
- (3) Because of structural variation
- (4) Its bioavailability will be increased

162 Match List I with List II.

List I	List II
A. Pteridophyte	I. <i>Salvia</i>
B. Bryophyte	II. <i>Ginkgo</i>
C. Angiosperm	III. <i>Polytrichum</i>
D. Gymnosperm	IV. <i>Salvinia</i>

Choose the option with all **correct** matches.

- (1) A-III, B-IV, C-II, D-I
- (2) A-IV, B-III, C-I, D-II
- (3) A-III, B-IV, C-I, D-II
- (4) A-IV, B-III, C-II, D-I

163 Who proposed that the genetic code for amino acids should be made up of three nucleotides?

- (1) George Gamow
- (2) Francis Crick
- (3) Jacques Monod
- (4) Franklin Stahl

164 Match List I with List II :

List I	List II
A. The Evil Quartet	I. Cryopreservation
B. Ex-situ conservation	II. Alien species invasion
C. <i>Lantana camara</i>	III. Causes of biodiversity losses
D. Dodo	IV. Extinction

Choose the option with all **correct** matches.

- (1) A-III, B-II, C-I, D-IV
- (2) A-III, B-I, C-II, D-IV
- (3) A-III, B-IV, C-II, D-I
- (4) A-III, B-II, C-IV, D-I

165 Which of the following hormones released from the pituitary is actually synthesized in the hypothalamus?

- (1) Luteinizing hormone (LH)
- (2) Anti-diuretic hormone (ADH)
- (3) Follicle-stimulating hormone (FSH)
- (4) Adenocorticotrophic hormone (ACTH)

166 Role of the water vascular system in Echinoderms is:

- A. Respiration and Locomotion
- B. Excretion and Locomotion
- C. Capture and transport of food
- D. Digestion and Respiration
- E. Digestion and Excretion

Choose the **correct** answer from the options given below :

- (1) A and B Only
- (2) A and C Only
- (3) B and C Only
- (4) B, D and E Only

167 Which of the following type of immunity is present at the time of birth and is a non-specific type of defence in the human body?

- (1) Acquired Immunity
- (2) Innate Immunity
- (3) Cell-mediated Immunity
- (4) Humoral Immunity

- 168 In bryophytes, the gemmae help in which one of the following?
- (1) Sexual reproduction
  - (2) Asexual reproduction
  - (3) Nutrient absorption
  - (4) Gaseous exchange
- 169 In frog, the Renal portal system is a special venous connection that acts to link :
- (1) Liver and intestine
  - (2) Liver and kidney
  - (3) Kidney and intestine
  - (4) Kidney and lower part of body
- 170 Given below are two statements :
- Statement I :** In ecosystem, there is unidirectional flow of energy of sun from producers to consumers.
- Statement II :** Ecosystems are exempted from 2<sup>nd</sup> law of thermodynamics.
- In the light of the above statements, choose the **most appropriate** answer from the options given below :
- (1) Both statement I and statement II are correct
  - (2) Both statement I and statement II are incorrect
  - (3) Statement I is correct but statement II is incorrect
  - (4) Statement I is incorrect but statement II is correct
- 171 Which of the following statements about RuBisCO is true?
- (1) It is active only in the dark.
  - (2) It has higher affinity for oxygen than carbon dioxide.
  - (3) It is an enzyme involved in the photolysis of water.
  - (4) It catalyzes the carboxylation of RuBP.
- 172 Which of the following enzyme(s) are NOT essential for gene cloning?
- A. Restriction enzymes
  - B. DNA ligase
  - C. DNA mutase
  - D. DNA recombinase
  - E. DNA polymerase
- Choose the **correct** answer from the options given below :
- (1) C and D only
  - (2) A and B only
  - (3) D and E only
  - (4) B and C only
- 173 Read the following statements on plant growth and development.
- A. Parthenocarpy can be induced by auxins.
  - B. Plant growth regulators can be involved in promotion as well as inhibition of growth.
  - C. Dedifferentiation is a pre-requisite for re-differentiation.
  - D. Abscisic acid is a plant growth promoter.
  - E. Apical dominance promotes the growth of lateral buds.
- Choose the option with all correct statements.
- (1) A, B, C only
  - (2) A, C, E only
  - (3) A, D, E only
  - (4) B, D, E only
- 174 Which factor is important for termination of transcription?
- (1)  $\alpha$  (alpha)
  - (2)  $\sigma$  (sigma)
  - (3)  $\rho$  (rho)
  - (4)  $\gamma$  (gamma)
- 175 Frogs respire in water by skin and buccal cavity and on land by skin, buccal cavity and lungs.
- Choose the **correct** answer from the following :
- (1) The statement is true for water but false for land
  - (2) The statement is true for both the environment
  - (3) The statement is false for water but true for land
  - (4) The statement is false for both the environment

176 Twins are born to a family that lives next door to you. The twins are a boy and a girl. Which of the following must be true?

- (1) They are monozygotic twins.
- (2) They are fraternal twins.
- (3) They were conceived through in vitro fertilization.
- (4) They have 75% identical genetic content.

177 Which of the following microbes is NOT involved in the preparation of household products?

- A. *Aspergillus niger*
- B. *Lactobacillus*
- C. *Trichoderma polysporum*
- D. *Saccharomyces cerevisiae*
- E. *Propionibacterium sharmanii*

Choose the correct answer from the options given below:

- (1) A and B only
- (2) A and C only
- (3) C and D only
- (4) C and E only

178 Match List - I with List - II.

List - I	List - II
A. Progesterone	I. Pars intermedia
B. Relaxin	II. Ovary
C. Melanocyte stimulating hormone	III. Adrenal Medulla
D. Catecholamines	IV. Corpus luteum

Choose the correct answer from the options given below :

- (1) A-IV, B-II, C-I, D-III
- (2) A-IV, B-II, C-III, D-I
- (3) A-II, B-IV, C-I, D-III
- (4) A-III, B-II, C-IV, D-I

179 The blue and white selectable markers have been developed which differentiate recombinant colonies from non-recombinant colonies on the basis of their ability to produce colour in the presence of a chromogenic substrate.

Given below are two statements about this method:

**Statement I:** The blue coloured colonies have DNA insert in the plasmid and they are identified as recombinant colonies.

**Statement II:** The colonies without blue colour have DNA insert in the plasmid and are identified as recombinant colonies.

In the light of the above statements, choose the most appropriate answer from the options given below

- (1) Both Statement I and Statement II are correct
- (2) Both Statement I and Statement II are incorrect
- (3) Statement I is correct but Statement II is incorrect
- (4) Statement I is incorrect but Statement II is correct

180 Which one of the following equations represents the Verhulst-Pearl Logistic Growth of population?

$$(1) \frac{dN}{dt} = r \left( \frac{K-N}{K} \right)$$

$$(2) \frac{dN}{dt} = rN \left( \frac{K-N}{K} \right)$$

$$(3) \frac{dN}{dt} = rN \left( \frac{N-K}{N} \right)$$

$$(4) \frac{dN}{dt} = N \left( \frac{r-K}{K} \right)$$

SPACE FOR ROUGH WORK

115460033

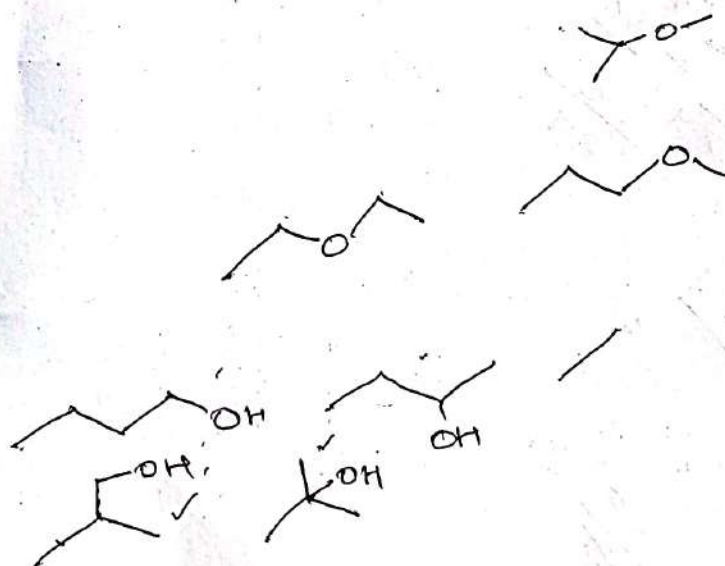

115460033



1s2 2s2 2p6 3s2 3p1

$$3(1) + 2(3) + 2 + \frac{1}{2} = 9 + 4 = 13$$

$$3a + 2b + c + \frac{10d}{24} + \frac{32}{24}$$

$$\frac{18}{24} + \frac{50}{24}$$

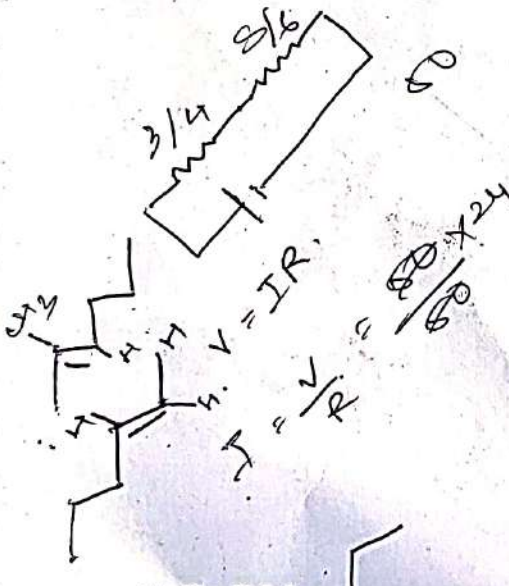



116224710

Test Booklet No.

Test Booklet Code

46

ENGLISH

NARMADA

Do not open this Test Booklet until you are asked to do so.

This Booklet contains 32 pages, including Rough Page.

**Important Instructions:**

1. The Answer Sheet is inside this Test Booklet. When you are directed to open the Test Booklet, take out the Answer Sheet and fill in the particulars on ORIGINAL Copy carefully with blue/black ball point pen only.
2. The test is of 3 hours duration and the Test Booklet contains 180 multiple-choice questions (four options with a single correct answer) from Physics, Chemistry and Biology (Botany and Zoology).
3. Wherever the symbols/constants are not mentioned, they are to be considered as per their standard meaning/value.
4. Each question carries 4 marks. For each correct response, the candidate will get 4 marks. For each incorrect response, one mark will be deducted from the total scores. The maximum marks are 720.
5. Use Blue/Black Ball Point Pen only for writing particulars on this page/markings responses on Answer Sheet.
6. Rough work is to be done in the space provided for this purpose in the Test Booklet only.
7. On completion of the test, the candidate must hand over the Answer Sheet (ORIGINAL and OFFICE Copy) to the Invigilator before leaving the Room/Hall. The candidates are allowed to take away this Test Booklet with them.
8. The CODE for this Booklet is "46". Make sure to enter this code in the OMR answer sheet.
9. The candidates should ensure that the Answer Sheet is not folded. Do not make any stray marks on the Answer Sheet. Do not write your Roll No. anywhere else except in the specified space in the Test Booklet/Answer Sheet.
10. Use of white fluid for correction is NOT permissible on the Answer Sheet.
11. Each candidate must show on-demand his/her Admit Card to the Invigilator.
12. No candidate, without special permission of the centre Superintendent or Invigilator, would leave his/her seat.
13. The candidates should not leave the Examination Hall without handing over their Answer Sheet to the Invigilator on duty and sign (with time) the Attendance Sheet twice. Cases, where a candidate has not signed the Attendance Sheet second time, will be deemed not to have handed over the Answer Sheet and dealt with as an Unfair Means case.
14. Use of Electronic/Manual Calculator is prohibited.
15. The candidates are governed by all Rules and Regulations of the examination with regard to their conduct in the Examination Room/Hall. All cases of unfair means will be dealt with as per the Rules and Regulations of this examination along with Public Examinations (Prevention of unfair means act 2024).
16. No part of the Test Booklet and Answer Sheet shall be detached under any circumstances.
17. The candidates will write the Correct Test Booklet Code as given in the Test Booklet/Answer Sheet in the Attendance Sheet.
18. If a candidate marks more than one answers for a question in the OMR Sheet, it will be treated as incorrect and negative marking will be applicable.

- 1 A physical quantity  $P$  is related to four observations  $a, b, c$  and  $d$  as follows:  

$$P = a^3 b^2 / c \sqrt{d}$$
 The percentage errors of measurement in  $a, b, c$  and  $d$  are 1%, 3%, 2%, and 4% respectively. The percentage error in the quantity  $P$  is  
 (1) 2% (2) 13%  
 (3) 15% (4) 10%
- 2 The intensity of transmitted light when a polaroid sheet, placed between two crossed polaroids at  $22.5^\circ$  from the polarization axis of one of the polaroid, is ( $I_0$  is the intensity of polarised light after passing through the first polaroid):  
 (1)  $\frac{I_0}{4}$  (2)  $\frac{I_0}{8}$   
 (3)  $\frac{I_0}{16}$  (4)  $\frac{I_0}{2}$
- 3 A 2 amp current is flowing through two different small circular copper coils having radii ratio 1:2. The ratio of their respective magnetic moments will be  
 (1) 1:2 (2) 2:1  
 (3) 4:1 (4) 1:4
- 4 Consider the diameter of a spherical object being measured with the help of a Vernier callipers. Suppose its 10 Vernier Scale Divisions (V.S.D.) are equal to its 9 Main Scale Divisions (M.S.D.). The least division in the M.S. is 0.1 cm and the zero of V.S. is at  $x = 0.1$  cm when the jaws of Vernier callipers are closed.  
 If the main scale reading for the diameter is  $M = 5$  cm and the number of coinciding vernier division is 8, the measured diameter after zero error correction, is  
 (1) 5.08 cm. (2) 4.98 cm  
 (3) 5.00 cm (4) 5.18 cm
- 5 A photon and an electron (mass  $m$ ) have the same energy  $E$ . The ratio  $(\lambda_{\text{photon}}/\lambda_{\text{electron}})$  of their de Broglie wavelengths is: ( $c$  is the speed of light)  
 (1)  $c\sqrt{2mE}$  (2)  $c\sqrt{\frac{2m}{E}}$   
 (3)  $\frac{1}{c}\sqrt{\frac{E}{2m}}$  (4)  $\sqrt{\frac{E}{2m}}$
- 6 De-Broglie wavelength of an electron orbiting in the  $n = 2$  state of hydrogen atom is close to (Given Bohr radius = 0.052 nm)  
 (1) 0.67 nm (2) 1.67 nm  
 (3) 2.67 nm (4) 0.067 nm
- 7 An unpolarized light beam travelling in air is incident on a medium of refractive index 1.73 at Brewster's angle. Then-  
 (1) reflected light is partially polarized and the angle of reflection is close to  $30^\circ$   
 (2) both reflected and transmitted light are perfectly polarized with angles of reflection and refraction close to  $60^\circ$  and  $30^\circ$ , respectively.  
 (3) transmitted light is completely polarized with angle of refraction close to  $30^\circ$   
 (4) reflected light is completely polarized and the angle of reflection is close to  $60^\circ$
- 8 The kinetic energies of two similar cars A and B are 100 J and 225 J respectively. On applying breaks, car A stops after 1000 m and car B stops after 1500 m. If  $F_A$  and  $F_B$  are the forces applied by the breaks on cars A and B, respectively, then the ratio  $F_A/F_B$  is  
 (1)  $\frac{2}{3}$  (2)  $\frac{1}{3}$   
 (3)  $\frac{1}{2}$  (4)  $\frac{3}{2}$

9 A wire of resistance  $R$  is cut into 8 equal pieces. From these pieces two equivalent resistances are made by adding four of these together in parallel. Then these two sets are added in series. The net effective resistance of the combination is :

- (1)  $\frac{R}{32}$  (2)  $\frac{R}{16}$   
 (3)  $\frac{R}{8}$  (4)  $\frac{R}{64}$

10 An oxygen cylinder of volume 30 litre has 18.20 moles of oxygen. After some oxygen is withdrawn from the cylinder, its gauge pressure drops to 11 atmospheric pressure at temperature  $27^\circ\text{C}$ . The mass of the oxygen withdrawn from the cylinder is nearly equal to:

[Given,  $R = \frac{100}{12} \text{ J mol}^{-1}\text{K}^{-1}$ , and molecular mass of  $\text{O}_2 = 32$ ]

- 1 atm pressure =  $1.01 \times 10^5 \text{ N/m}^2$   
 (1) 0.144 kg (2) 0.116 kg  
 (3) 0.156 kg (4) 0.125 kg

11 In a certain camera, a combination of four similar thin convex lenses are arranged axially in contact. Then the power of the combination and the total magnification in comparison to the power ( $p$ ) and magnification ( $m$ ) for each lens will be, respectively

- (1)  $p^4$  and  $4m$  (2)  $4p$  and  $m^4$   
 (3)  $p^4$  and  $m^4$  (4)  $4p$  and  $4m$

12 AB is a part of an electrical circuit (see figure). The potential difference " $V_A - V_B$ ", at the instant when current  $i = 2 \text{ A}$  and is increasing at a rate of 1 amp / second is:

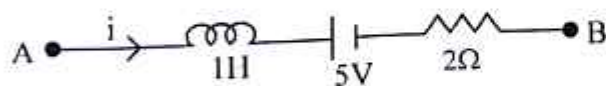

- (1) 6 volt (2) 9 volt  
 (3) 10 volt (4) 5 volt

13 A body weighs 48 N on the surface of the earth. The gravitational force experienced by the body due to the earth at a height equal to one-third the radius of the earth from its surface is :

- (1) 27 N (2) 32 N  
 (3) 36 N (4) 16 N

14 A full wave rectifier circuit with diodes ( $D_1$ ) and ( $D_2$ ) is shown in the figure. If input supply voltage  $V_{in} = 220\sin(100\pi t)$  volt, then at  $t = 15 \text{ msec}$

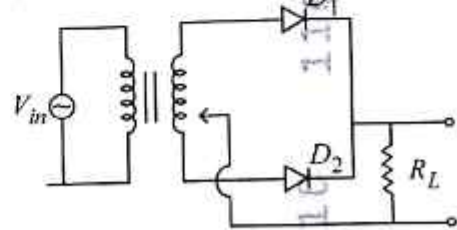

- (1)  $D_1$  is reverse biased,  $D_2$  is forward biased  
 (2)  $D_1$  and  $D_2$  both are forward biased  
 (3)  $D_1$  and  $D_2$  both are reverse biased  
 (4)  $D_1$  is forward biased,  $D_2$  is reverse biased

15 Two cities X and Y are connected by a regular bus service with a bus leaving in either direction every  $T$  min. A girl is driving scooter with a speed of 60 km/h in the direction X to Y notices that a bus goes past her every 30 minutes in the direction of her motion, and every 10 minutes in the opposite direction. Choose the correct option for the period  $T$  of the bus service and the speed (assumed constant) of the buses.

- (1) 25 min, 100 km/h  
 (2) 10 min, 90 km/h  
 (3) 15 min, 120 km/h  
 (4) 9 min, 40 km/h

- 16 The Sun rotates around its centre once in 27 days. What will be the period of revolution if the Sun were to expand to twice its present radius without any external influence? Assume the Sun to be a sphere of uniform density.
- (1) 105 days (2) 115 days  
(3) 108 days (4) 100 days

- 17 The electric field in a plane electromagnetic wave is given by

$$E_z = 60 \cos(5x + 1.5 \times 10^9 t) \text{ V/m}$$

Then expression for the corresponding magnetic field is (here subscripts denote the direction of the field):

- (1)  $B_x = 2 \times 10^{-7} \cos(5x + 1.5 \times 10^9 t) \text{ T}$   
 (2)  $B_z = 60 \cos(5x + 1.5 \times 10^9 t) \text{ T}$   
 (3)  $B_y = 60 \sin(5x + 1.5 \times 10^9 t) \text{ T}$   
 (4)  $B_y = 2 \times 10^{-7} \cos(5x + 1.5 \times 10^9 t) \text{ T}$

- 18 Two identical charged conducting spheres A and B have their centres separated by a certain distance. Charge on each sphere is  $q$  and the force of repulsion between them is  $F$ . A third identical uncharged conducting sphere is brought in contact with sphere A first and then with B and finally removed from both. New force of repulsion between spheres A and B (Radii of A and B are negligible compared to the distance of separation so that for calculating force between them they can be considered as point charges) is best given as:

- (1)  $\frac{2F}{3}$  (2)  $\frac{F}{2}$   
 (3)  $\frac{3F}{8}$  (4)  $\frac{3F}{5}$

46\_English ]

- 19 An electric dipole with dipole moment  $5 \times 10^{-6} \text{ Cm}$  is aligned with the direction of a uniform electric field of magnitude  $4 \times 10^5 \text{ N/C}$ . The dipole is then rotated through an angle of  $60^\circ$  with respect to the electric field. The change in the potential energy of the dipole is:

- (1) 1.0 J (2) 1.2 J  
(3) 1.5 J (4) 0.8 J

- 20 A microscope has an objective of focal length 2 cm, eyepiece of focal length 4 cm and the tube length of 40 cm. If the distance of distinct vision of eye is 25 cm, the magnification in the microscope is

- (1) 125 (2) 150  
(3) 250 (4) 100

- 21 The output (Y) of the given logic implementation is similar to the output of an \_\_\_\_\_ gate.

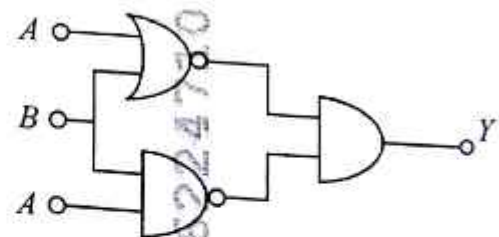

- (1) NAND  
(2) OR  
(3) NOR  
(4) AND

22 A uniform rod of mass 20 kg and length 5 m leans against a smooth vertical wall making an angle of  $60^\circ$  with it. The other end rests on a rough horizontal floor. The friction force that the floor exerts on the rod is (take  $g = 10 \text{ m/s}^2$ )

- (1)  $100\sqrt{3} \text{ N}$       (2) 200 N  
 (3)  $200\sqrt{3} \text{ N}$       (4) 100 N

23 The current passing through the battery in the given circuit, is:

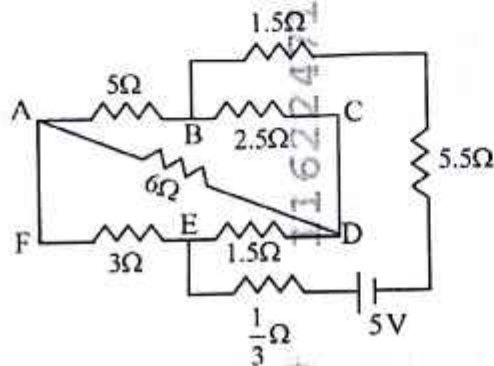

- (1) 0.5 A      (2) 2.5 A  
 (3) 1.5 A      (4) 2.0 A

24 A model for quantized motion of an electron in a uniform magnetic field  $B$  states that the flux passing through the orbit of the electron is  $n(h/e)$  where  $n$  is an integer,  $h$  is Planck's constant and  $e$  is the magnitude of electron's charge. According to the model, the magnetic moment of an electron in its lowest energy state will be ( $m$  is the mass of the electron)

- (1)  $\frac{he}{2\pi m}$       (2)  $\frac{heB}{\pi m}$   
 (3)  $\frac{heB}{2\pi m}$       (4)  $\frac{he}{\pi m}$

25 Which of the following options represent the variation of photoelectric current with property of light shown on the x-axis?

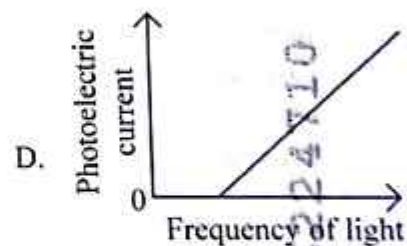
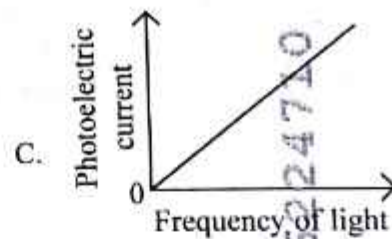
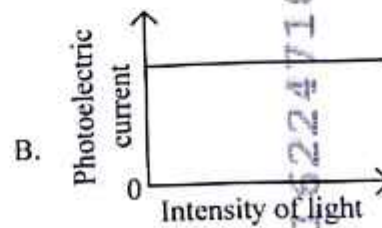
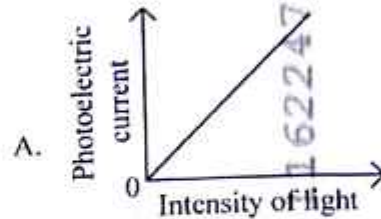

- (1) A and C      (2) A and D  
 (3) B and D      (4) A only

26 An electron (mass  $9 \times 10^{-31}$  kg and charge  $1.6 \times 10^{-19}$  C) moving with speed  $c/100$  ( $c =$  speed of light) is injected into a magnetic field  $\vec{B}$  of magnitude  $9 \times 10^{-4}$  T perpendicular to its direction of motion. We wish to apply a uniform electric field  $\vec{E}$  together with the magnetic field so that the electron does not deflect from its path. Then (speed of light  $c = 3 \times 10^8$  ms $^{-1}$ )

- (1)  $\vec{E}$  is perpendicular to  $\vec{B}$  and its magnitude is  $27 \times 10^2$  V m $^{-1}$
- (2)  $\vec{E}$  is parallel to  $\vec{B}$  and its magnitude is  $27 \times 10^2$  V m $^{-1}$
- (3)  $\vec{E}$  is parallel to  $\vec{B}$  and its magnitude is  $27 \times 10^4$  V m $^{-1}$
- (4)  $\vec{E}$  is perpendicular to  $\vec{B}$  and its magnitude is  $27 \times 10^4$  V m $^{-1}$

27 Consider a water tank shown in the figure. It has one wall at  $x = L$  and can be taken to be very wide in the  $z$  direction. When filled with a liquid of surface tension  $S$  and density  $\rho$ , the liquid surface makes angle  $\theta_0$  ( $\theta_0 \ll 1$ ) with the  $x$ -axis at  $x = L$ . If  $y(x)$  is the height of the surface then the equation for  $y(x)$  is :

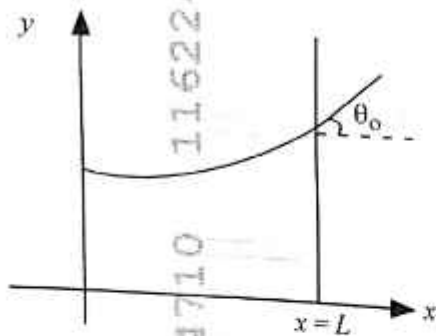

(take  $\theta(x) = \sin \theta(x) = \tan \theta(x) = \frac{dy}{dx}$ ,  $g$  is the acceleration due to gravity)

- (1)  $\frac{d^2 y}{dx^2} = \frac{\rho g}{S} y$
- (2)  $\frac{d^2 y}{dx^2} = \sqrt{\frac{\rho g}{S}}$
- (3)  $\frac{dy}{dx} = \sqrt{\frac{\rho g}{S}} x$
- (4)  $\frac{d^2 y}{dx^2} = \frac{\rho g}{S} x$

28 A pipe open at both ends has a fundamental frequency  $f$  in air. The pipe is now dipped vertically in a water drum to half of its length. The fundamental frequency of the air column is now equal to :

- (1)  $f$
- (2)  $\frac{3f}{2}$
- (3)  $2f$
- (4)  $\frac{f}{2}$

29 A parallel plate capacitor made of circular plates is being charged such that the surface charge density on its plates is increasing at a constant rate with time. The magnetic field arising due to displacement current is :

- (1) constant between the plates and zero outside the plates
- (2) non-zero everywhere with maximum at the imaginary cylindrical surface connecting peripheries of the plates
- (3) zero between the plates and non-zero outside
- (4) zero at all places

30 Three identical heat conducting rods are connected in series as shown in the figure. The rods on the sides have thermal conductivity  $2K$  while that in the middle has thermal conductivity  $K$ . The left end of the combination is maintained at temperature  $3T$  and the right end at  $T$ . The rods are thermally insulated from outside. In steady state, temperature at the left junction is  $T_1$  and that at the right junction is  $T_2$ . The ratio  $T_1/T_2$  is

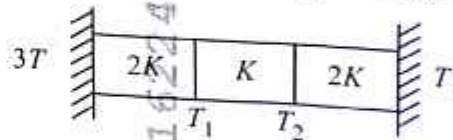

- (1)  $\frac{4}{3}$
- (2)  $\frac{5}{3}$
- (3)  $\frac{5}{4}$
- (4)  $\frac{3}{2}$

- 31 A constant voltage of 50 V is maintained between the points A and B of the circuit shown in the figure. The current through the branch CD of the circuit is :

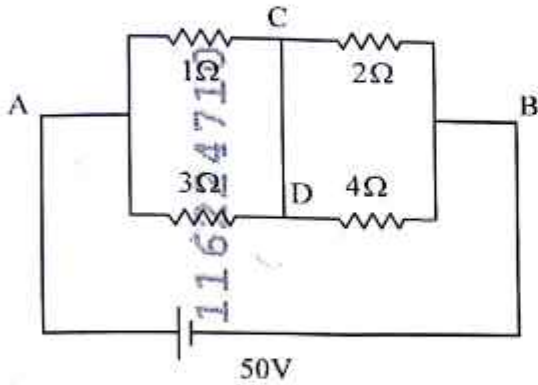

- (1) 2.0 A (2) 2.5 A  
 (3) 3.0 A (4) 1.5 A
- 32 In some appropriate units, time ( $t$ ) and position ( $x$ ) relation of a moving particle is given by  $t = x^2 + x$ . The acceleration of the particle is
- (1)  $-\frac{2}{(2x+1)^3}$  (2)  $+\frac{2}{(x+1)^3}$   
 (3)  $+\frac{2}{2x+1}$  (4)  $-\frac{2}{(x+2)^3}$
- 33 Two gases A and B are filled at the same pressure in separate cylinders with movable pistons of radius  $r_A$  and  $r_B$ , respectively. On supplying an equal amount of heat to both the systems reversibly under constant pressure, the pistons of gas A and B are displaced by 16 cm and 9 cm, respectively. If the change in their internal energy is the same, then the ratio  $r_A/r_B$  is equal to

- (1)  $\frac{3}{4}$  (2)  $\frac{2}{\sqrt{3}}$   
 (3)  $\frac{\sqrt{3}}{2}$  (4)  $\frac{4}{3}$

- 34 In an oscillating spring mass system, a spring is connected to a box filled with sand. As the box oscillates, sand leaks slowly out of the box vertically so that the average frequency  $\omega(t)$  and average amplitude  $A(t)$  of the system change with time  $t$ . Which one of the following options schematically depicts these changes correctly?

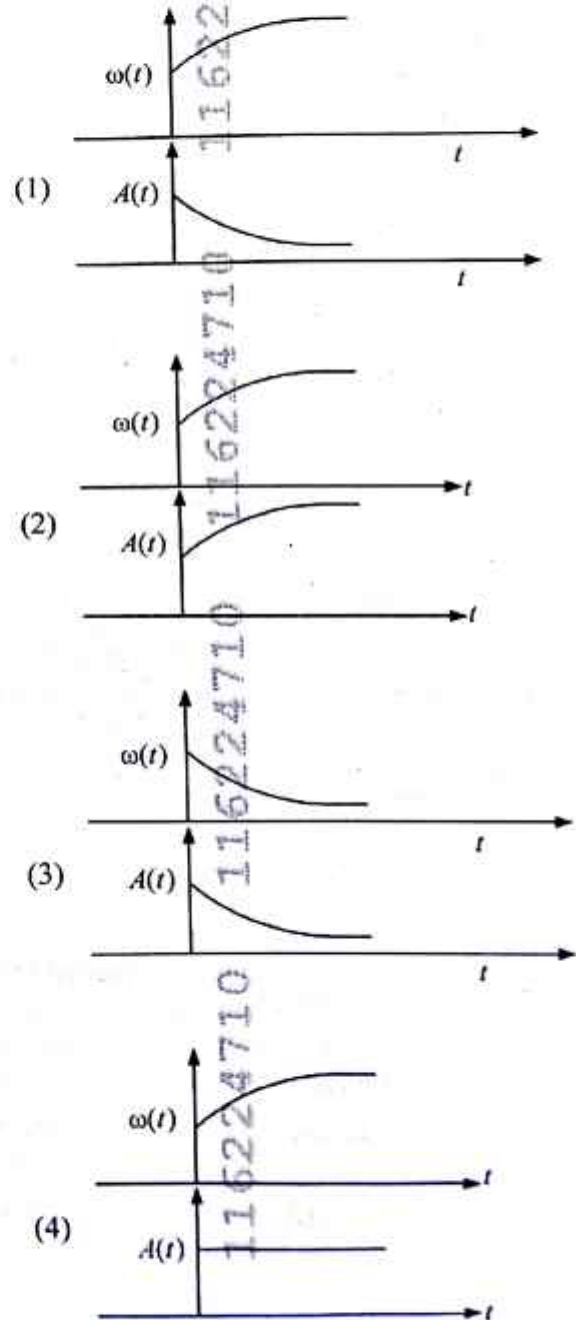

- 35 A sphere of radius  $R$  is cut from a larger solid sphere of radius  $2R$  as shown in the figure. The ratio of the moment of inertia of the smaller sphere to that of the rest part of the sphere about the Y-axis is:

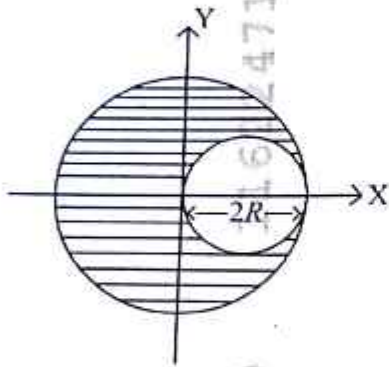

- (1)  $\frac{7}{40}$  (2)  $\frac{7}{57}$   
 (3)  $\frac{7}{64}$  (4)  $\frac{7}{8}$

- 36 The plates of a parallel plate capacitor are separated by  $d$ . Two slabs of different dielectric constant  $K_1$  and  $K_2$  with thickness  $\frac{3}{8}d$  and  $\frac{d}{2}$ , respectively are inserted in the capacitor. Due to this, the capacitance becomes two times larger than when there is nothing between the plates.

If  $K_1 = 1.25 K_2$ , the value of  $K_1$  is :

- (1) 2.33 (2) 1.60  
 (3) 1.33 (4) 2.66

- 37 There are two inclined surfaces of equal length ( $L$ ) and same angle of inclination  $45^\circ$  with the horizontal. One of them is rough and the other is perfectly smooth. A given body takes 2 times as much time to slide down on rough surface than on the smooth surface. The coefficient of kinetic friction ( $\mu_k$ ) between the object and the rough surface is close to

- (1) 0.40 (2) 0.5  
 (3) 0.75 (4) 0.25

- 38 A bob of heavy mass  $m$  is suspended by a light string of length  $l$ . The bob is given a horizontal velocity  $v_0$  as shown in figure. If the string gets slack at some point  $P$  making an angle  $\theta$  from the horizontal, the ratio of the speed  $v$  of the bob at point  $P$  to its initial speed  $v_0$  is:

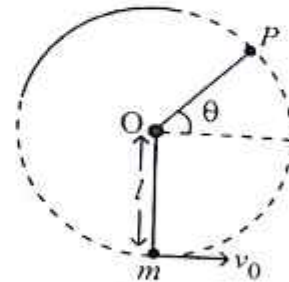

- (1)  $\left(\frac{1}{2+3 \sin \theta}\right)^{1/2}$   
 (2)  $\left(\frac{\cos \theta}{2+3 \sin \theta}\right)^{1/2}$   
 (3)  $\left(\frac{\sin \theta}{2+3 \sin \theta}\right)^{1/2}$   
 (4)  $(\sin \theta)^{1/2}$

- 39 A container has two chambers of volumes  $V_1 = 2$  litres and  $V_2 = 3$  litres separated by a partition made of a thermal insulator. The chambers contains  $n_1 = 5$  and  $n_2 = 4$  moles of ideal gas at pressures  $p_1 = 1$  atm and  $p_2 = 2$  atm, respectively. When the partition is removed, the mixture attains an equilibrium pressure of :

- (1) 1.6 atm (2) 1.4 atm  
 (3) 1.8 atm (4) 1.3 atm

40 To an ac power supply of 220 V at 50 Hz, a resistor of  $20\ \Omega$ , a capacitor of reactance  $25\ \Omega$  and an inductor of reactance  $45\ \Omega$  are connected in series. The corresponding current in the circuit and the phase angle between the current and the voltage is, respectively -

- (1) 7.8 A and  $45^\circ$
- (2) 15.6 A and  $30^\circ$
- (3) 15.6 A and  $45^\circ$
- (4) 7.8 A and  $30^\circ$

41 The radius of Martian orbit around the Sun is about 4 times the radius of the orbit of Mercury. The Martian year is 687 Earth days. Then which of the following is the length of 1 year on Mercury ?

- (1) 225 earth days
- (2) 172 earth days
- (3) 124 earth days
- (4) 88 earth days

42 A balloon is made of a material of surface tension  $S$  and its inflation outlet (from where gas is filled in it) has small area  $A$ . It is filled with a gas of density  $\rho$  and takes a spherical shape of radius  $R$ . When the gas is allowed to flow freely out of it, its radius  $r$  changes from  $R$  to 0 (zero) in time  $T$ . If the speed  $v(r)$  of gas coming out of the balloon depends on  $r$  as  $r^a$  and  $T \propto S^\alpha A^\beta \rho^\gamma R^\delta$  then

- (1)  $a = -\frac{1}{2}, \alpha = \frac{1}{2}, \beta = -1, \gamma = -\frac{1}{2}, \delta = \frac{5}{2}$
- (2)  $a = -\frac{1}{2}, \alpha = \frac{1}{2}, \beta = -1, \gamma = \frac{1}{2}, \delta = \frac{7}{2}$
- (3)  $a = \frac{1}{2}, \alpha = \frac{1}{2}, \beta = -\frac{1}{2}, \gamma = \frac{1}{2}, \delta = \frac{7}{2}$
- (4)  $a = \frac{1}{2}, \alpha = \frac{1}{2}, \beta = -1, \gamma = +1, \delta = \frac{3}{2}$

43 A particle of mass  $m$  is moving around the origin with a constant force  $F$  pulling it towards the origin. If Bohr model is used to describe its motion, the radius  $r$  of the  $n^{\text{th}}$  orbit and the particle's speed  $v$  in the orbit depend on  $n$  as

- (1)  $r \propto n^{1/3}; v \propto n^{2/3}$
- (2)  $r \propto n^{2/3}; v \propto n^{1/3}$
- (3)  $r \propto n^{4/3}; v \propto n^{-1/3}$
- (4)  $r \propto n^{1/3}; v \propto n^{1/3}$

44 Two identical point masses  $P$  and  $Q$ , suspended from two separate massless springs of spring constants  $k_1$  and  $k_2$ , respectively, oscillate vertically. If their maximum speeds are the same, the ratio ( $A_Q/A_P$ ) of the amplitude  $A_Q$  of mass  $Q$  to the amplitude  $A_P$  of mass  $P$  is:

- (1)  $\frac{k_1}{k_2}$
- (2)  $\sqrt{\frac{k_2}{k_1}}$
- (3)  $\sqrt{\frac{k_1}{k_2}}$
- (4)  $\frac{k_2}{k_1}$

45 A ball of mass 0.5 kg is dropped from a height of 40 m. The ball hits the ground and rises to a height of 10 m. The impulse imparted to the ball during its collision with the ground is (Take  $g = 9.8\ \text{m/s}^2$ )

- (1) 7 NS
- (2) 0
- (3) 84 NS
- (4) 21 NS

[ Contd...

46 Given below are two statements :  
**Statement I** : Ferromagnetism is considered as an extreme form of paramagnetism.  
**Statement II** : The number of unpaired electrons in a  $\text{Cr}^{2+}$  ion ( $Z=24$ ) is the same as that of a  $\text{Nd}^{3+}$  ion ( $Z=60$ ).  
 In the light of the above statements, choose the correct answer from the options given below:

- (1) Both Statement I and Statement II are false
- (2) Statement I is true but Statement II is false
- (3) Statement I is false but Statement II is true
- (4) Both Statement I and Statement II are true

47 For the reaction  $\text{A(g)} \rightleftharpoons 2\text{B(g)}$ , the backward reaction rate constant is higher than the forward reaction rate constant by a factor of 2500, at 1000 K.

[Given :  $R = 0.0831 \text{ J atm mol}^{-1} \text{ K}^{-1}$ ]

$K_p$  for the reaction at 1000 K is

- (1)  $2.077 \times 10^5$
- (2) 0.033
- (3) 0.021
- (4) 83.1

48 Total number of possible isomers (both structural as well as stereoisomers) of cyclic ethers of molecular formula  $\text{C}_4\text{H}_8\text{O}$  is :

- (1) 8
- (2) 10
- (3) 11
- (4) 6

49 Given below are two statements :

**Statement I** : A hypothetical diatomic molecule with bond order zero is quite stable.

**Statement II** : As bond order increases, the bond length increases.

In the light of the above statements, choose the most appropriate answer from the options given below :

- (1) Both Statement I and Statement II are false
- (2) Statement I is true but Statement II is false
- (3) Statement I is false but Statement II is true
- (4) Both Statement I and Statement II are true

46\_English]

50 Identify the suitable reagent for the following conversion.

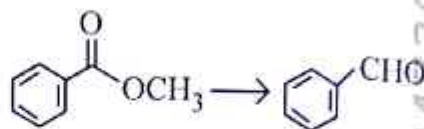

- (1) (i)  $\text{AlH}(\text{iBu})_2$  (ii)  $\text{H}_2\text{O}$
- (2) (i)  $\text{NaBH}_4$ , (ii)  $\text{H}^+/\text{H}_2\text{O}$
- (3)  $\text{H}_2 / \text{Pd-BaSO}_4$
- (4) (i)  $\text{LiAlH}_4$ , (ii)  $\text{H}^+/\text{H}_2\text{O}$

51 The major product of the following reaction is:

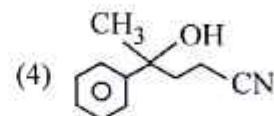
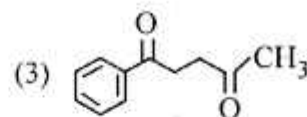
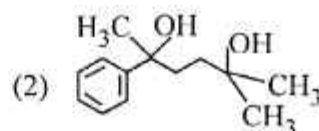
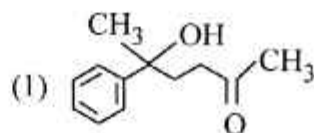
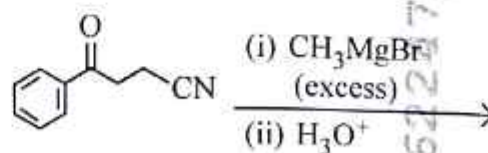

52 If the molar conductivity ( $\Lambda_m$ ) of a  $0.050 \text{ mol L}^{-1}$  solution of a monobasic weak acid is  $90 \text{ S cm}^2 \text{ mol}^{-1}$ , its extent (degree) of dissociation will be

[Assume  $\Lambda_+^\circ = 349.6 \text{ S cm}^2 \text{ mol}^{-1}$  and

$\Lambda_-^\circ = 50.4 \text{ S cm}^2 \text{ mol}^{-1}$ .]

- (1) 0.125
- (2) 0.225
- (3) 0.215
- (4) 0.115

53 Which one of the following reactions does NOT belong to "Lassaigne's test"?

- (1)  $2\text{Na} + \text{S} \xrightarrow{\Delta} \text{Na}_2\text{S}$   
 (2)  $\text{Na} + \text{X} \xrightarrow{\Delta} \text{NaX}$   
 (3)  $2\text{CuO} + \text{C} \xrightarrow{\Delta} 2\text{Cu} + \text{CO}_2$   
 (4)  $\text{Na} + \text{C} + \text{N} \xrightarrow{\Delta} \text{NaCN}$

54 The correct order of decreasing acidity of the following aliphatic acids is :

- (1)  $\text{CH}_3\text{COOH} > (\text{CH}_3)_2\text{CHCOOH} > (\text{CH}_3)_3\text{CCOOH} > \text{HCOOH}$   
 (2)  $\text{HCOOH} > \text{CH}_3\text{COOH} > (\text{CH}_3)_2\text{CHCOOH} > (\text{CH}_3)_3\text{CCOOH}$   
 (3)  $\text{HCOOH} > (\text{CH}_3)_3\text{CCOOH} > (\text{CH}_3)_2\text{CHCOOH} > \text{CH}_3\text{COOH}$   
 (4)  $(\text{CH}_3)_3\text{CCOOH} > (\text{CH}_3)_2\text{CHCOOH} > \text{CH}_3\text{COOH} > \text{HCOOH}$

55 Match List I with List II

List I (Name of Vitamin)	List II (Deficiency disease)
A. Vitamin B <sub>12</sub>	I. Cheilosis
B. Vitamin D	II. Convulsions
C. Vitamin B <sub>2</sub>	III. Rickets
D. Vitamin B <sub>6</sub>	IV. Pernicious anaemia

Choose the correct answer from the options given below :

- (1) A-IV, B-III, C-I, D-II  
 (2) A-II, B-III, C-I, D-IV  
 (3) A-IV, B-III, C-II, D-I  
 (4) A-I, B-III, C-II, D-IV

56 Out of the following complex compounds, which of the compound will be having the minimum conductance in solution?

- (1)  $[\text{Co}(\text{NH}_3)_4\text{Cl}_2]$   
 (2)  $[\text{Co}(\text{NH}_3)_6]\text{Cl}_3$   
 (3)  $[\text{Co}(\text{NH}_3)_5\text{Cl}]\text{Cl}$   
 (4)  $[\text{Co}(\text{NH}_3)_3\text{Cl}_3]$

57 Sugar 'X'

- A. is found in honey.  
 B. is a keto sugar.  
 C. exists in  $\alpha$  and  $\beta$  anomeric forms.  
 D. is laevorotatory.

'X' is :

- (1) D-Fructose      (2) Maltose  
 (3) Sucrose        (4) D-Glucose

58 How many products (including stereoisomers) are expected from monochlorination of the following compound?

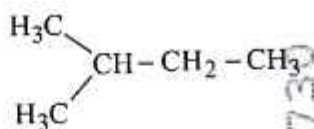

- (1) 3                      (2) 5  
 (3) 6                      (4) 2

59 Which one of the following compounds can exist as cis-trans isomers?

- (1) 2-Methylhex-2-ene  
 (2) 1,1-Dimethylcyclopropane  
 (3) 1,2-Dimethylcyclohexane  
 (4) Pent-1-ene

60 Which one of the following reactions does NOT give benzene as the product?

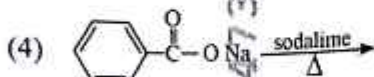
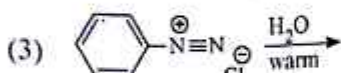
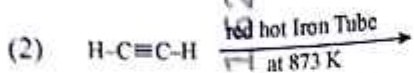
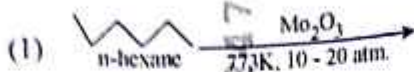

61 Phosphoric acid ionizes in three steps with their ionization constant values

$K_{a_1}$ ,  $K_{a_2}$  and  $K_{a_3}$ , respectively,

while  $K$  is the overall ionization constant.

Which of the following statements are true?

A.  $\log K = \log K_{a_1} + \log K_{a_2} + \log K_{a_3}$

B.  $\text{H}_3\text{PO}_4$  is a stronger acid than  $\text{H}_2\text{PO}_4^-$  and  $\text{HPO}_4^{2-}$ .

C.  $K_{a_1} > K_{a_2} > K_{a_3}$

D.  $K_{a_1} = \frac{K_{a_3}}{K_{a_2}}$

Choose the correct answer from the options given below:

- (1) A and C only
- (2) B, C and D only
- (3) A, B and C only
- (4) A and B only

46\_English ]

12

62 Among the following, choose the ones with equal number of atoms.

- A. 212 g of  $\text{Na}_2\text{CO}_3$  (s) [molar mass = 106 g]
- B. 248 g of  $\text{Na}_3\text{O}$  (s) [molar mass = 62 g]
- C. 240 g of  $\text{NaOH}$  (s) [molar mass = 40 g]
- D. 12 g of  $\text{H}_2$  (g) [molar mass = 2 g]
- E. 220 g of  $\text{CO}_2$  (g) [molar mass = 44 g]

Choose the correct answer from the options given below :

- (1) A, B, and D only
- (2) B, C, and D only
- (3) B, D, and E only
- (4) A, B, and C only

63 Given below are two statements :

**Statement I :** Like nitrogen that can form ammonia, arsenic can form arsine.

**Statement II :** Antimony cannot form antimony pentoxide.

In the light of the above statements, choose the most appropriate answer from the options given below

- (1) Both Statement I and Statement II are incorrect
- (2) Statement I is correct but Statement II is incorrect
- (3) Statement I is incorrect but Statement II is correct
- (4) Both Statement I and Statement II are correct

64 Dalton's Atomic theory could not explain which of the following?

- (1) Law of constant proportion
- (2) Law of multiple proportion
- (3) Law of gaseous volume
- (4) Law of conservation of mass

[ Contd...

65 The correct order of decreasing basic strength of the given amines is :

- (1) N-ethylethanamine > ethanamine > benzenamine > N-methylaniline
- (2) N-ethylethanamine > ethanamine > N-methylaniline > benzenamine
- (3) benzenamine > ethanamine > N-methylaniline > N-ethylethanamine
- (4) N-methylaniline > benzenamine > ethanamine > N-ethylethanamine

66 Which of the following statements are true?

- A. Unlike Ga that has a very high melting point, Cs has a very low melting point.
- B. On Pauling scale, the electronegativity values of N and Cl are not the same.
- C. Ar, K<sup>+</sup>, Cl<sup>-</sup>, Ca<sup>2+</sup>, and S<sup>2-</sup> are all isoelectronic species.
- D. The correct order of the first ionization enthalpies of Na, Mg, Al, and Si is Si > Al > Mg > Na.
- E. The atomic radius of Cs is greater than that of Li and Rb.

Choose the correct answer from the options given below :

- (1) C and E only
- (2) C and D only
- (3) A, C, and E only
- (4) A, B, and E only

67 Match List - I with List - II

- | List-I               | List-II  |
|----------------------|--|
| A. XeO <sub>3</sub>  | I. sp <sup>3</sup> d; linear                               |
| B. XeF <sub>2</sub>  | II. sp <sup>3</sup> ; pyramidal                            |
| C. XeOF <sub>4</sub> | III. sp <sup>3</sup> d <sup>3</sup> ; distorted octahedral |
| D. XeF <sub>6</sub>  | IV. sp <sup>3</sup> d <sup>2</sup> ; square pyramidal      |

Choose the correct answer from the options given below :

- (1) A-II, B-I, C-III, D-IV
- (2) A-IV, B-II, C-III, D-I
- (3) A-IV, B-II, C-I, D-III
- (4) A-II, B-I, C-IV, D-III

68 The standard heat of formation, in kcal/mol of Ba<sup>2+</sup> is :

- [Given : standard heat of formation of SO<sub>4</sub><sup>2-</sup> ion (aq) = - 216 kcal/mol, standard heat of crystallisation of BaSO<sub>4</sub>(s) = - 4.5 kcal/mol, standard heat of formation of BaSO<sub>4</sub>(s) = - 349 kcal/mol]
- (1) - 133.0
  - (2) + 133.0
  - (3) + 220.5
  - (4) - 128.5

69 Among the given compounds I-III, the correct order of bond dissociation energy of C-H bond marked with \* is :

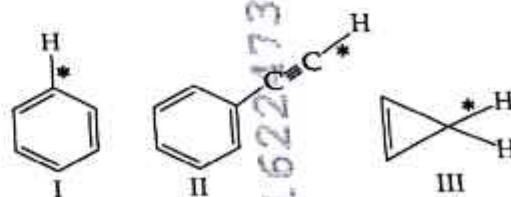

- (1) I > II > III
- (2) III > II > I
- (3) II > III > I
- (4) II > I > III

70 Predict the major product 'P' in the following sequence of reactions -

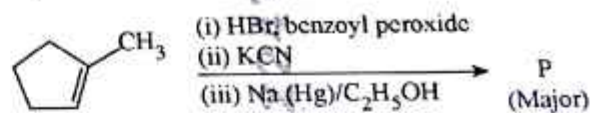

- (1)
- (2)
- (3)
- (4)

71 Match List - I with List - II

List-I	List-II
A. Haber process	I. Fe catalyst
B. Wacker oxidation	II. PdCl <sub>2</sub>
C. Wilkinson catalyst	III. [(PPh <sub>3</sub> ) <sub>3</sub> RhCl]
D. Ziegler catalyst	IV. TiCl <sub>4</sub> with Al(CH <sub>3</sub> ) <sub>3</sub>

Choose the **correct** answer from the options given below :

- (1) A-II, B-III, C-I, D-IV
- (2) A-I, B-II, C-III, D-IV
- (3) A-I, B-IV, C-III, D-II
- (4) A-I, B-II, C-IV, D-III



72 Energy and radius of first Bohr orbit of He<sup>+</sup> and Li<sup>2+</sup> are

[Given R<sub>H</sub> = 2.18 × 10<sup>-18</sup> J, a<sub>0</sub> = 52.9 pm]

- (1) E<sub>n</sub>(Li<sup>2+</sup>) = -8.72 × 10<sup>-18</sup> J;  
r<sub>n</sub>(Li<sup>2+</sup>) = 26.4 pm  
E<sub>n</sub>(He<sup>+</sup>) = 19.62 × 10<sup>-18</sup> J;  
r<sub>n</sub>(He<sup>+</sup>) = 17.6 pm
- (2) E<sub>n</sub>(Li<sup>2+</sup>) = -19.62 × 10<sup>-16</sup> J;  
r<sub>n</sub>(Li<sup>2+</sup>) = 17.6 pm  
E<sub>n</sub>(He<sup>+</sup>) = -8.72 × 10<sup>-16</sup> J;  
r<sub>n</sub>(He<sup>+</sup>) = 26.4 pm
- (3) E<sub>n</sub>(Li<sup>2+</sup>) = -8.72 × 10<sup>-16</sup> J;  
r<sub>n</sub>(Li<sup>2+</sup>) = 17.6 pm  
E<sub>n</sub>(He<sup>+</sup>) = 19.62 × 10<sup>-16</sup> J;  
r<sub>n</sub>(He<sup>+</sup>) = 17.6 pm
- (4) E<sub>n</sub>(Li<sup>2+</sup>) = -19.62 × 10<sup>-18</sup> J;  
r<sub>n</sub>(Li<sup>2+</sup>) = 17.6 pm  
E<sub>n</sub>(He<sup>+</sup>) = -8.72 × 10<sup>-18</sup> J;  
r<sub>n</sub>(He<sup>+</sup>) = 26.4 pm

46\_English ]

73 Given below are two statements : one is labelled as Assertion (A) and the other is labelled as Reason (R).

Assertion (A) :  I undergoes S<sub>N</sub>2 reaction faster than  Cl.

Reason (R) : Iodine is a better leaving group because of its large size.

In the light of the above statements, choose the **correct** answer from the options given below:

- (1) Both A and R are true but R is not the correct explanation of A
- (2) A is true but R is false
- (3) A is false but R is true
- (4) Both A and R are true and R is the correct explanation of A

74 If the half-life (t<sub>1/2</sub>) for a first order reaction is 1 minute, then the time required for 99.9% completion of the reaction is closest to :

- (1) 4 minutes
- (2) 5 minutes
- (3) 10 minutes
- (4) 2 minutes

75 Which of the following aqueous solution will exhibit highest boiling point?

- (1) 0.01M KNO<sub>3</sub>
- (2) 0.01M Na<sub>2</sub>SO<sub>4</sub>
- (3) 0.015M C<sub>6</sub>H<sub>12</sub>O<sub>6</sub>
- (4) 0.01M Urea

76 Higher yield of NO in N<sub>2</sub>(g) + O<sub>2</sub>(g) ⇌ 2NO(g) can be obtained at

[ΔH of the reaction = + 180.7 kJ mol<sup>-1</sup>]

- A. higher temperature
- B. lower temperature
- C. higher concentration of N<sub>2</sub>
- D. higher concentration of O<sub>2</sub>

Choose the **correct** answer from the options given below:

- (1) B, C only
- (2) B, C, D only
- (3) A, C, D only
- (4) A, D only

77 Match List I with List II

List I (Ion)	List II (Group Number in Cation Analysis)
A. $\text{Co}^{2+}$	I. Group-I
B. $\text{Mg}^{2+}$	II. Group-III
C. $\text{Pb}^{2+}$	III. Group-IV
D. $\text{Al}^{3+}$	IV. Group-VI

Choose the **correct** answer from the options given below :

- (1) A-III, B-IV, C-I, D-II  
 (2) A-III, B-II, C-IV, D-I  
 (3) A-III, B-II, C-I, D-IV  
 (4) A-III, B-IV, C-II, D-I

78 The ratio of the wavelengths of the light absorbed by a Hydrogen atom when it undergoes  $n = 2 \rightarrow n = 3$  and  $n = 4 \rightarrow n = 6$  transitions, respectively, is

- (1)  $\frac{16}{9}$  (2)  $\frac{1}{9}$   
 (3)  $\frac{1}{4}$  (4)  $\frac{1}{36}$

79 The correct order of the wavelength of light absorbed by the following complexes is,

- A.  $[\text{Co}(\text{NH}_3)_6]^{3+}$  B.  $[\text{Co}(\text{CN})_6]^{3-}$   
 C.  $[\text{Cu}(\text{H}_2\text{O})_4]^{2+}$  D.  $[\text{Ti}(\text{H}_2\text{O})_6]^{3+}$

Choose the **correct** answer from the options given below:

- (1)  $B < A < D < C$  (2)  $C < D < A < B$   
 (3)  $C < A < D < B$  (4)  $B < D < A < C$

80 Identify the correct orders against the property mentioned

- A.  $\text{H}_2\text{O} > \text{NH}_3 > \text{CHCl}_3$  - dipole moment  
 B.  $\text{XeF}_4 > \text{XeO}_3 > \text{XeF}_2$  - number of lone pairs on central atom  
 C.  $\text{O-H} > \text{C-H} > \text{N-O}$  - bond length  
 D.  $\text{N}_2 > \text{O}_2 > \text{H}_2$  - bond enthalpy

Choose the **correct** answer from the options given below :

- (1) B, D only (2) A, C only  
 (3) B, C only (4) A, D only

81 Match List I with List II

List I (Mixture)	List II (Method of Separation)
A. $\text{CHCl}_3 + \text{C}_6\text{H}_5\text{NH}_2$	I. Distillation under reduced pressure
B. Crude oil in petroleum industry	II. Steam distillation
C. Glycerol from spent-lye	III. Fractional distillation
D. Aniline - water	IV. Simple distillation

Choose the **correct** answer from the options given below :

- (1) A-IV, B-III, C-II, D-I  
 (2) A-III, B-IV, C-I, D-II  
 (3) A-III, B-IV, C-II, D-I  
 (4) A-IV, B-III, C-I, D-II

82 If the rate constant of a reaction is  $0.03 \text{ s}^{-1}$ , how much time does it take for  $7.2 \text{ mol L}^{-1}$  concentration of the reactant to get reduced to  $0.9 \text{ mol L}^{-1}$ ?

(Given:  $\log 2 = 0.301$ )

- (1) 23.1 s (2) 210 s  
 (3) 21.0 s (4) 69.3 s

83 Which among the following electronic configurations belong to main group elements?

- A.  $[\text{Ne}]3s^1$                       B.  $[\text{Ar}]3d^3 4s^2$   
 C.  $[\text{Kr}]4d^{10} 5s^2 5p^5$         D.  $[\text{Ar}]3d^{10} 4s^1$   
 E.  $[\text{Rn}]5f^0 6d^2 7s^2$

Choose the **correct** answer from the option given below:

- (1) A and C only  
 (2) D and E only  
 (3) A, C and D only  
 (4) B and E only

84 Match List - I with List - II

List-I (Example)	List-II (Type of Solution)
A. Humidity	I. Solid in solid
B. Alloys	II. Liquid in gas
C. Amalgams	III. Solid in gas
D. Smoke	IV. Liquid in solid

Choose the **correct** answer from the options given below:

- (1) A-II, B-I, C-IV, D-III  
 (2) A-III, B-I, C-IV, D-II  
 (3) A-III, B-II, C-I, D-IV  
 (4) A-II, B-IV, C-I, D-III

85 5 moles of liquid X and 10 moles of liquid Y make a solution having a vapour pressure of 70 torr. The vapour pressures of pure X and Y are 63 torr and 78 torr respectively. Which of the following is true regarding the described solution?

- (1) The solution shows negative deviation.  
 (2) The solution is ideal.  
 (3) The solution has volume greater than the sum of individual volumes.  
 (4) The solution shows positive deviation.

86  $\text{C}(\text{s}) + 2\text{H}_2(\text{g}) \rightarrow \text{CH}_4(\text{g}); \Delta H = -74.8 \text{ kJ mol}^{-1}$   
 Which of the following diagrams gives an accurate representation of the above reaction? [R  $\rightarrow$  reactants; P  $\rightarrow$  products]

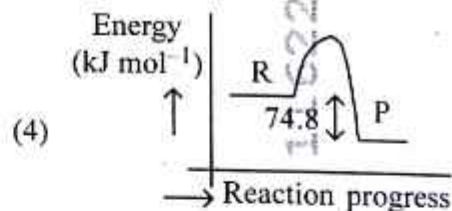
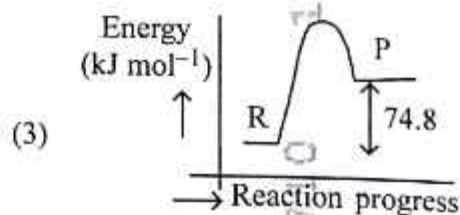
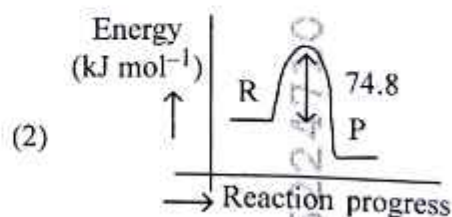
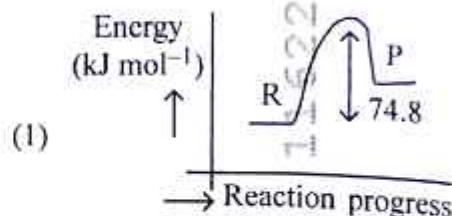

87 Which one of the following compounds **does not** decolorize bromine water?

- (1)
- (2)
- (3)
- (4)

- 88 Consider the following compounds :  
 $\text{KO}_2$ ,  $\text{H}_2\text{O}_2$  and  $\text{H}_2\text{SO}_4$ .  
 The oxidation states of the underlined elements in them are, respectively,
- (1) +2, -2, and +6
  - (2) +1, -2, and +4
  - (3) +4, -4, and +6
  - (4) +1, -1, and +6

- 89 Given below are two statements :

**Statement I :** Benzenediazonium salt is prepared by the reaction of aniline with nitrous acid at 273 - 278 K. It decomposes easily in the dry state.

**Statement II :** Insertion of iodine into the benzene ring is difficult and hence iodobenzene is prepared through the reaction of benzenediazonium salt with KI.

In the light of the above statements, choose the **most appropriate** answer from the options given below :

- (1) Both Statement I and Statement II are incorrect
- (2) Statement I is correct but Statement II is incorrect
- (3) Statement I is incorrect but Statement II is correct
- (4) Both Statement I and Statement II are correct

- 90 Which of the following are paramagnetic?

- A.  $[\text{NiCl}_4]^{2-}$       B.  $\text{Ni}(\text{CO})_4$   
 C.  $[\text{Ni}(\text{CN})_4]^{2-}$       D.  $[\text{Ni}(\text{H}_2\text{O})_6]^{2+}$   
 E.  $\text{Ni}(\text{PPh}_3)_4$

Choose the **correct** answer from the options given below:

- (1) B and E only
- (2) A and D only
- (3) A, D and E only
- (4) A and C only

- 91 Match List - I with List - II.

List - I	List - II
A. Progesterone	I. Pars intermedia
B. Relaxin	II. Ovary
C. Melanocyte stimulating hormone	III. Adrenal Medulla
D. Catecholamines	IV. Corpus luteum

Choose the **correct** answer from the options given below :

- (1) A-IV, B-II, C-III, D-I
- (2) A-II, B-IV, C-I, D-III
- (3) A-III, B-II, C-IV, D-I
- (4) A-IV, B-II, C-I, D-III

- 92 The blue and white selectable markers have been developed which differentiate recombinant colonies from non-recombinant colonies on the basis of their ability to produce colour in the presence of a chromogenic substrate.

Given below are two statements about this method:

**Statement I :** The blue coloured colonies have DNA insert in the plasmid and they are identified as recombinant colonies.

**Statement II :** The colonies without blue colour have DNA insert in the plasmid and are identified as recombinant colonies.

In the light of the above statements, choose the **most appropriate** answer from the options given below :

- (1) Both Statement I and Statement II are incorrect
- (2) Statement I is correct but Statement II is incorrect
- (3) Statement I is incorrect but Statement II is correct
- (4) Both Statement I and Statement II are correct

93 Given below are two statements : One is labelled as Assertion (A) and the other is labelled as Reason (R).

Assertion (A) : Cells of the tapetum possess dense cytoplasm and generally have more than one nucleus.

Reason (R) : Presence of more than one nucleus in the tapetum increases the efficiency of nourishing the developing microspore mother cells.

In light of the above statements, choose the most appropriate answer from the options given below :

- (1) Both A and R are true but R is NOT the correct explanation of A
- (2) A is true but R is false
- (3) A is false but R is true
- (4) Both A and R are true and R is the correct explanation of A

94 Match List I with List II.

List I	List II
A. Pteridophyte	I. <i>Salvia</i>
B. Bryophyte	II. <i>Ginkgo</i>
C. Angiosperm	III. <i>Polytrichum</i>
D. Gymnosperm	IV. <i>Salvinia</i>

Choose the option with all correct matches.

- (1) A-IV, B-III, C-I, D-II
- (2) A-III, B-IV, C-I, D-II
- (3) A-IV, B-III, C-II, D-I
- (4) A-III, B-IV, C-II, D-I

95 Match List - I with List - II.

List - I	List - II
A. Heart	I. Erythropoietin
B. Kidney	II. Aldosterone
C. Gastro-intestinal tract	III. Atrial natriuretic factor
D. Adrenal Cortex	IV. Secretin

Choose the correct answer from the options given below :

- (1) A-IV, B-III, C-II, D-I
- (2) A-I, B-III, C-IV, D-II
- (3) A-III, B-I, C-IV, D-II
- (4) A-II, B-I, C-III, D-IV

96 Who proposed that the genetic code for amino acids should be made up of three nucleotides?

- (1) Francis Crick
- (2) Jacque Monod
- (3) Franklin Stahl
- (4) George Gamow

97 Which of the following is the unit of productivity of an Ecosystem?

- (1) KCal  $m^{-2}$
- (2) KCal  $m^{-3}$
- (3) (KCal  $m^{-2}$ )  $yr^{-1}$
- (4)  $gm^{-2}$

98 Which of the following is an example of a zygomorphic flower?

- |                   |                    |
|-------------------|--------------------|
| (1) <i>Datura</i> | (2) Pea            |
| (3) Chilli        | (4) <i>Petunia</i> |

99 Match List I with List II :

List I	List II
A. The Evil Quartet	I. Cryopreservation
B. Ex situ conservation	II. Alien species invasion
C. <i>Lantana camara</i>	III. Causes of biodiversity losses
D. Dodo	IV. Extinction

Choose the option with all correct matches.

- (1) A-III, B-I, C-II, D-IV
- (2) A-III, B-IV, C-II, D-I
- (3) A-III, B-II, C-IV, D-I
- (4) A-III, B-II, C-I, D-IV

100 Given below are two statements :  
**Statement I :** In ecosystem, there is unidirectional flow of energy of sun from producers to consumers.

**Statement II :** Ecosystems are exempted from 2<sup>nd</sup> law of thermodynamics.

In the light of the above statements, choose the most appropriate answer from the options given below :

- (1) Both statement I and statement II are incorrect
- (2) Statement I is correct but statement II is incorrect
- (3) Statement I is incorrect but statement II is correct
- (4) Both statement I and statement II are correct

101 The protein portion of an enzyme is called :

- (1) Coenzyme
- (2) Apoenzyme
- (3) Prosthetic group
- (4) Cofactor

102 Twins are born to a family that lives next door to you. The twins are a boy and a girl. Which of the following must be true?

- (1) They are fraternal twins.
- (2) They were conceived through in vitro fertilization.
- (3) They have 75% identical genetic content.
- (4) They are monozygotic twins.

103 After maturation, in primary lymphoid organs, the lymphocytes migrate for interaction with antigens to secondary lymphoid organ(s) / tissue(s) like:

- A. thymus
- B. bone marrow
- C. spleen
- D. lymph nodes
- E. Peyer's patches

Choose the correct answer from the options given below:

- (1) A, B, C only
- (2) E, A, B only
- (3) C, D, E only
- (4) B, C, D only

104 In frog, the Renal portal system is a special venous connection that acts to link :

- (1) Liver and kidney
- (2) Kidney and intestine
- (3) Kidney and lower part of body
- (4) Liver and intestine

105 Which of the following enzyme(s) are NOT essential for gene cloning?

- A. Restriction enzymes
- B. DNA ligase
- C. DNA mutase
- D. DNA recombinase
- E. DNA polymerase

Choose the correct answer from the options given below :

- (1) A and B only
- (2) D and E only
- (3) B and C only
- (4) C and D only

106 With the help of given pedigree, find out the probability for the birth of a child having no disease and being a carrier (has the disease mutation in one allele of the gene) in F<sub>3</sub> generation.

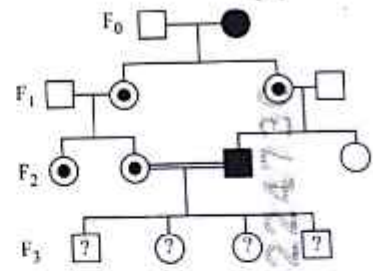

- Unaffected male
- Affected male
- Carrier female
- Unaffected female
- Affected female

- (1) 1/2
- (2) 1/8
- (3) Zero
- (4) 1/4

- 107 Which one of the following is the characteristic feature of gymnosperms?  
 (1) Seeds are naked.  
 (2) Seeds are absent.  
 (3) Gymnosperms have flowers for reproduction.  
 (4) Seeds are enclosed in fruits.
- 108 The first menstruation is called :  
 (1) Menarche (2) Diapause  
 (3) Ovulation (4) Menopause
- 109 In bryophytes, the gemmae help in which one of the following?  
 (1) Asexual reproduction  
 (2) Nutrient absorption  
 (3) Gaseous exchange  
 (4) Sexual reproduction
- 110 How many meiotic and mitotic divisions need to occur for the development of a mature female gametophyte from the megaspore mother cell in an angiosperm plant?  
 (1) 1 Meiosis and 2 Mitosis  
 (2) 1 Meiosis and 3 Mitosis  
 (3) No Meiosis and 2 Mitosis  
 (4) 2 Meiosis and 3 Mitosis
- 111 Role of the water-vascular system in Echinoderms is:  
 A. Respiration and Locomotion  
 B. Excretion and Locomotion  
 C. Capture and transport of food  
 D. Digestion and Respiration  
 E. Digestion and Excretion  
 Choose the **correct** answer from the options given below :  
 (1) A and C Only  
 (2) B and C Only  
 (3) B, D and E Only  
 (4) A and B Only

- 112 Read the following statements on plant growth and development.  
 A. Parthenocary can be induced by auxins.  
 B. Plant growth regulators can be involved in promotion as well as inhibition of growth.  
 C. Dedifferentiation is a pre-requisite for re-differentiation.  
 D. Abscisic acid is a plant growth promoter.  
 E. Apical dominance promotes the growth of lateral buds.  
 Choose the option with all correct statements.  
 (1) A, C, E only (2) A, D, E only  
 (3) B, D, E only (4) A, B, C only

- 113 Which of the following type of immunity is present at the time of birth and is a non-specific type of defence in the human body?  
 (1) Innate Immunity  
 (2) Cell-mediated Immunity  
 (3) Humoral Immunity  
 (4) Acquired Immunity
- 114 Why can't insulin be given orally to diabetic patients?  
 (1) It will be digested in Gastro-Intestinal (GI) tract  
 (2) Because of structural variation  
 (3) Its bioavailability will be increased  
 (4) Human body will elicit strong immune response

- 115 Which one of the following equations represents the Verhulst-Pearl Logistic Growth of population?  
 (1)  $\frac{dN}{dt} = rN \left( \frac{K-N}{K} \right)$   
 (2)  $\frac{dN}{dt} = rN \left( \frac{N-K}{N} \right)$   
 (3)  $\frac{dN}{dt} = N \left( \frac{r-K}{K} \right)$   
 (4)  $\frac{dN}{dt} = r \left( \frac{K-N}{K} \right)$

116 Silencing of specific mRNA is possible via RNAi because of -

- (1) Inhibitory ssRNA
- (2) Complementary tRNA
- (3) Non-complementary ssRNA
- (4) Complementary dsRNA

117 Match List I with List II.

List I

- A. Adenosine
- B. Adenylic acid
- C. Adenine
- D. Alanine

List II

- I. Nitrogen base
- II. Nucleotide
- III. Nucleoside
- IV. Amino acid

Choose the option with all correct matches.

- (1) A-III, B-II, C-IV, D-I
- (2) A-III, B-II, C-I, D-IV
- (3) A-II, B-III, C-I, D-IV
- (4) A-III, B-IV, C-II, D-I

118 Frogs respire in water by skin and buccal cavity and on land by skin, buccal cavity and lungs.

Choose the correct answer from the following :

- (1) The statement is true for both the environment
- (2) The statement is false for water but true for land
- (3) The statement is false for both the environment
- (4) The statement is true for water but false for land

119 All living members of the class Cyclostomata are:

- (1) Endoparasite
- (2) Symbiotic
- (3) Ectoparasite
- (4) Free living

120 Identify the statement that is NOT correct.

- (1) The heavy and light chains are held together by disulfide bonds.
- (2) Antigen binding site is located at C-terminal region of antibody molecules.
- (3) Constant region of heavy and light chains are located at C-terminus of antibody molecules.
- (4) Each antibody has two light and two heavy chains.

121 Given below are two statements : one is labelled as Assertion (A) and the other is labelled as Reason (R).

**Assertion (A) :** The primary function of the Golgi apparatus is to package the materials made by the endoplasmic reticulum and deliver it to intracellular targets and outside the cell.

**Reason (R) :** Vesicles containing materials made by the endoplasmic reticulum fuse with the cis face of the Golgi apparatus, and they are modified and released from the trans face of the Golgi apparatus.

In the light of the above statements, choose the correct answer from the options given below:

- (1) Both A and R are true but R is not the correct explanation of A
- (2) A is true but R is false
- (3) A is false but R is true
- (4) Both A and R are true and R is the correct explanation of A

122 Consider the following :

- A. The reductive division for the human female gametogenesis starts earlier than that of the male gametogenesis.
- B. The gap between the first meiotic division and the second meiotic division is much shorter for males compared to females.
- C. The first polar body is associated with the formation of the primary oocyte.
- D. Luteinizing Hormone (LH) surge leads to disintegration of the endometrium and onset of menstrual bleeding.

Choose the **correct** answer from the options given below :

- (1) A and C are true
- (2) B and D are true
- (3) B and C are true
- (4) A and B are true

123 Match List I with List II :

List I	List II
A. Scutellum	I. Persistent nucellus
B. Non-albuminous seed	II. Cotyledon of Monocot seed
C. Epiblast	III. Groundnut
D. Perisperm	IV. Rudimentary cotyledon

Choose the option with all **correct** matches.

- (1) A-IV, B-III, C-II, D-I
- (2) A-IV, B-III, C-I, D-II
- (3) A-II, B-IV, C-III, D-I
- (4) A-II, B-III, C-IV, D-I

124 What is the main function of the spindle fibers during mitosis ?

- (1) To synthesize new DNA
- (2) To repair damaged DNA
- (3) To regulate cell growth
- (4) To separate the chromosomes

125 Which of the following statements about RuBisCO is true?

- (1) It has higher affinity for oxygen than carbon dioxide.
- (2) It is an enzyme involved in the photolysis of water.
- (3) It catalyzes the carboxylation of RuBP.
- (4) It is active only in the dark.

126 Given below are two statements :

**Statement I :** The DNA fragments extracted from gel electrophoresis can be used in construction of recombinant DNA.

**Statement II :** Smaller size DNA fragments are observed near anode while larger fragments are found near the wells in an agarose gel.

In the light of the above statements, choose the **most appropriate** answer from the options given below :

- (1) Both statement I and statement II are incorrect
- (2) Statement I is correct but statement II is incorrect
- (3) Statement I is incorrect but statement II is correct
- (4) Both statement I and statement II are correct

127 Which factor is important for termination of transcription?

- (1)  $\sigma$  (sigma)
- (2)  $\rho$  (rho)
- (3)  $\gamma$  (gamma)
- (4)  $\alpha$  (alpha)

128 Consider the following statements regarding function of adrenal medullary hormones :

- A. It causes pupillary constriction
- B. It is a hyperglycemic hormone
- C. It causes piloerection
- D. It increases strength of heart contraction

Choose the **correct** answer from the options given below :

- (1) B, C and D Only
- (2) A, C and D Only
- (3) D Only
- (4) C and D Only

- 129 Histones are enriched with -
- (1) Leucine & Lysine
  - (2) Phenylalanine & Leucine
  - (3) Phenylalanine & Arginine
  - (4) Lysine & Arginine
- 130 Genes R and Y follow independent assortment. If RRYy produce round yellow seeds and rryy produce wrinkled green seeds, what will be the phenotypic ratio of the F<sub>2</sub> generation?
- (1) Phenotypic ratio - 3 : 1
  - (2) Phenotypic ratio - 9 : 3 : 3 : 1
  - (3) Phenotypic ratio - 9 : 7
  - (4) Phenotypic ratio - 1 : 2 : 1
- 131 Which of the following hormones released from the pituitary is actually synthesized in the hypothalamus ?
- (1) Anti-diuretic hormone (ADH)
  - (2) Follicle-stimulating hormone (FSH)
  - (3) Adenocorticotrophic hormone (ACTH)
  - (4) Luteinizing hormone (LH)
- 132 Given below are two statements : one is labelled as **Assertion (A)** and the other is labelled as **Reason (R)**.
- Assertion (A) :** All vertebrates are chordates but all chordates are not vertebrate.
- Reason (R) :** The members of subphylum vertebrata possess notochord during the embryonic period, the notochord is replaced by a cartilaginous or bony vertebral column in adults.
- In the light of the above statements, choose the **correct** answer from the options given below:
- (1) Both A and R are true but R is **not** the correct explanation of A
  - (2) A is true but R is false
  - (3) A is false but R is true
  - (4) Both A and R are true and R is the correct explanation of A

- 133 Given below are two statements :
- Statement I :** Fig fruit is a non-vegetarian fruit as it has enclosed fig wasps in it.
- Statement II :** Fig wasp and fig tree exhibit mutual relationship as fig wasp completes its life cycle in fig fruit and fig fruit gets pollinated by fig wasp.
- In the light of the above statements, choose the **most appropriate** answer from the options given below :
- (1) Both statement I and statement II are incorrect
  - (2) Statement I is correct but statement II is incorrect
  - (3) Statement I is incorrect but statement II is correct
  - (4) Both statement I and statement II are correct
- 134 Sweet potato and potato represent a certain type of evolution. Select the correct combination of terms to explain the evolution.
- (1) Homology, divergent
  - (2) Homology, convergent
  - (3) Analogy, divergent
  - (4) Analogy, convergent
- 135 Which of the following microbes is **NOT** involved in the preparation of household products?
- A. *Aspergillus niger*
  - B. *Lactobacillus*
  - C. *Trichoderma polysporum*
  - D. *Saccharomyces cerevisiae*
  - E. *Propionibacterium sharmanii*
- Choose the **correct** answer from the options given below:
- (1) A and C only
  - (2) C and D only
  - (3) C and E only
  - (4) A and B only

- 136 Identify the part of a bio-reactor which is used as a foam breaker from the given figure.

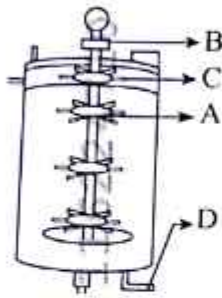

- (1) B (2) D  
(3) C (4) A

- 137 Name the class of enzyme that usually catalyze the following reaction :

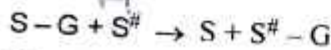

Where, G → a group other than hydrogen

S → a substrate

S<sup>#</sup> → another substrate

- (1) Lyase (2) Transferase  
(3) Ligase (4) Hydrolase

- 138 Match List I with List II :

List I	List II
A. Chlorophyll a	I. Yellow-green
B. Chlorophyll b	II. Yellow
C. Xanthophylls	III. Blue-green
D. Carotenoids	IV. Yellow to Yellow-orange

Choose the option with all correct matches.

- (1) A-III, B-I, C-II, D-IV  
(2) A-I, B-II, C-IV, D-III  
(3) A-I, B-IV, C-III, D-II  
(4) A-III, B-IV, C-II, D-I

- 139 The correct sequence of events in the life cycle of bryophytes is:
- Fusion of antherozoid with egg.
  - Attachment of gametophyte to substratum.
  - Reduction division to produce haploid spores.
  - Formation of sporophyte.
  - Release of antherozoids into water.

Choose the correct answer from the options given below :

- (1) B, E, A, C; D (2) B, E, A, D, C  
(3) D, E, A, B; C (4) D, E, A, C, B

- 140 Match List - I with List - II.

List - I	List - II
A. Centromere	I. Mitochondrion
B. Cilium	II. Cell division
C. Cristae	III. Cell movement
D. Cell membrane	IV. Phospholipid Bilayer

Choose the correct answer from the options given below :

- (1) A-II, B-I, C-IV, D-III  
(2) A-IV, B-II, C-III, D-I  
(3) A-II, B-III, C-I, D-IV  
(4) A-I, B-II, C-III, D-IV

- 141 Find the correct statements :

- In human pregnancy, the major organ systems are formed at the end of 12 weeks.
- In human pregnancy the major organ systems are formed at the end of 8 weeks.
- In human pregnancy heart is formed after one month of gestation.
- In human pregnancy, limbs and digits develop by the end of second month.
- In human pregnancy the appearance of hair is usually observed in the fifth month.

Choose the correct answer from the options given below :

- (1) B and C Only  
(2) B, C, D and E Only  
(3) A, C, D and E Only  
(4) A and E Only

142 Each of the following characteristics represent a Kingdom proposed by Whittaker. Arrange the following in increasing order of complexity of body organization.

- A. Multicellular heterotrophs with cell wall made of chitin.
- B. Heterotrophs with tissue/organ/organ system level of body organization.
- C. Prokaryotes with cell wall made of polysaccharides and amino acids.
- D. Eukaryotic autotrophs with tissue/organ level of body organization.
- E. Eukaryotes with cellular body organization.

Choose the correct answer from the options given below :

- (1) C, E, A, D, B (2) A, C, E, D, B  
(3) C, E, A, B, D (4) A, C, E, B, D

143 Which are correct:

- A. Computed tomography and magnetic resonance imaging detect cancers of internal organs.
- B. Chemotherapeutic drugs are used to kill non-cancerous cells.
- C.  $\alpha$ -interferon activate the cancer patients' immune system and helps in destroying the tumour.
- D. Chemotherapeutic drugs are biological response modifiers.
- E. In the case of leukaemia blood cell counts are decreased.

Choose the correct answer from the options given below:

- (1) D and E only (2) C and D only  
(3) A and C only (4) B and D only

144 Which of the following genetically engineered organisms was used by Eli Lilly to prepare human insulin?

- (1) Yeast (2) Virus  
(3) Phage (4) Bacterium

145 What is the pattern of inheritance for polygenic trait?

- (1) Non-mendelian inheritance pattern
- (2) Autosomal dominant pattern
- (3) X-linked recessive inheritance pattern
- (4) Mendelian inheritance pattern

146 Which of the following are the post-transcriptional events in an eukaryotic cell?

- A. Transport of pre-mRNA to cytoplasm prior to splicing.
- B. Removal of introns and joining of exons.
- C. Addition of methyl group at 5' end of hnRNA.
- D. Addition of adenine residues at 3' end of hnRNA.
- E. Base pairing of two complementary RNAs.

Choose the correct answer from the options given below :

- (1) B, C, D only (2) B, C, E only  
(3) C, D, E only (4) A, B, C only

147 Which one of the following phytohormones promotes nutrient mobilization which helps in the delay of leaf senescence in plants?

- (1) Abscisic acid (2) Gibberellin  
(3) Cytokinin (4) Ethylene

148 Which one of the following statements refers to Reductionist Biology?

- (1) Physiological approach to study and understand living organisms.
- (2) Chemical approach to study and understand living organisms.
- (3) Behavioural approach to study and understand living organisms.
- (4) Physico-chemical approach to study and understand living organisms.

149 Match List - I with List - II.

List - I List - II

- A. Emphysema I. Rapid spasms in muscle due to low  $Ca^{++}$  in body fluid
- B. Angina Pectoris II. Damaged alveolar walls and decreased respiratory surface
- C. Glomerulonephritis III. Acute chest pain when not enough oxygen is reaching to heart muscle
- D. Tetany IV. Inflammation of glomeruli of kidney

Choose the correct answer from the options given below :

- (1) A-III, B-I, C-II, D-IV  
(2) A-II, B-IV, C-III, D-I  
(3) A-II, B-III, C-IV, D-I  
(4) A-III, B-I, C-IV, D-II

150 Epiphytes that are growing on a mango branch is an example of which of the following?

- (1) Mutualism (2) Predation  
(3) Amensalism (4) Commensalism

151 Match List I with List II :

List-I

- A. Alfred Hershey and Martha Chase I. Streptococcus pneumoniae

List-II

- B. Euchromatin II. Densely packed and dark-stained
- C. Frederick Griffith III. Loosely packed and light-stained
- D. Heterochromatin IV. DNA as genetic material

Choose the correct answer from the options given below :

- (1) A-IV, B-II, C-I, D-III  
(2) A-IV, B-III, C-I, D-II  
(3) A-III, B-II, C-IV, D-I  
(4) A-II, B-IV, C-I, D-III

46\_English ]

152

Which chromosome in the human genome has the highest number of genes?

- (1) Chromosome Y  
(2) Chromosome 1  
(3) Chromosome 10  
(4) Chromosome X

153

What are the potential drawbacks in adoption of the IVF method?

- A. High fatality risk to mother  
B. Expensive instruments and reagents  
C. Husband/wife necessary for being donors  
D. Less adoption of orphans  
E. Not available in India  
F. Possibility that the early embryo does not survive

Choose the correct answer from the options given below :

- (1) A, C, D, E only  
(2) A, B, C, E only  
(3) A, B, C, E, F only  
(4) B, D, F only

154 Match List - I with List - II.

List - I

List - II

- A. Head I. Enzymes
- B. Middle piece II. Sperm motility
- C. Acrosome III. Energy
- D. Tail IV. Genetic material

Choose the correct answer from the options given below :

- (1) A-IV, B-III, C-II, D-I  
(2) A-III, B-IV, C-II, D-I  
(3) A-III, B-II, C-I, D-IV  
(4) A-IV, B-III, C-I, D-II

155 From the statements given below choose the correct option :

- A. The eukaryotic ribosomes are 80S and prokaryotic ribosomes are 70S.
- B. Each ribosome has two sub-units.
- C. The two sub-units of 80S ribosome are 60S and 40S while that of 70S are 50S and 30S.
- D. The two sub-units of 80S ribosome are 60S and 20S and that of 70S are 50S and 20S.
- E. The two sub-units of 80S are 60S and 30S and that of 70S are 50S and 30S.

- (1) A, B, D are true
- (2) A, B, E are true
- (3) B, D, E are true
- (4) A, B, C are true

156 Which of the following is an example of non-distilled alcoholic beverage produced by yeast?

- (1) Brandy
- (2) Beer
- (3) Rum
- (4) Whisky

157 Who is known as the father of Ecology in India?

- (1) Ramdeo Misra
- (2) Ram Udar
- (3) Birbal Sahni
- (4) S. R. Kashyap

158 In the seeds of cereals, the outer covering of endosperm separates the embryo by a protein-rich layer called :

- (1) Coleorhiza
- (2) Integument
- (3) Aleurone layer
- (4) Coleoptile

159 Which of the following statement is correct about location of the male frog copulatory pad?

- (1) First digit of hind limb
- (2) Second digit of fore limb
- (3) First digit of the fore limb
- (4) First and Second digit of fore limb

160 A specialised membranous structure in a prokaryotic cell which helps in cell wall formation, DNA replication and respiration is:

- (1) Chromatophores
- (2) Cristae
- (3) Endoplasmic Reticulum
- (4) Mesosome

161 Given below are two statements :

**Statement I :** Transfer RNAs and ribosomal RNA do not interact with mRNA.

**Statement II :** RNA interference (RNAi) takes place in all eukaryotic organisms as a method of cellular defence.

In the light of the above statements, choose the most appropriate answer from the options given below :

- (1) Both Statement I and Statement II are incorrect
- (2) Statement I is correct but Statement II is incorrect
- (3) Statement I is incorrect but Statement II is correct
- (4) Both Statement I and Statement II are correct

162 What is the name of the blood vessel that carries deoxygenated blood from the body to the heart in a frog ?

- (1) Pulmonary artery
- (2) Pulmonary vein
- (3) Vena cava
- (4) Aorta

163 Given below are two statements :

**Statement I :** In the RNA world, RNA is considered the first genetic material evolved to carry out essential life processes. RNA acts as a genetic material and also as a catalyst for some important biochemical reactions in living systems. Being reactive, RNA is unstable.

**Statement II :** DNA evolved from RNA and is a more stable genetic material. Its double helical strands being complementary, resist changes by evolving repairing mechanism.

In the light of the above statements, choose the **most appropriate** answer from the options given below :

- (1) Both statement I and statement II are incorrect
- (2) Statement I is correct but statement II is incorrect
- (3) Statement I is incorrect but statement II is correct
- (4) Both statement I and statement II are correct

164 Which one of the following is an example of ex-situ conservation?

- (1) Wildlife Sanctuary
- (2) Zoos and botanical gardens
- (3) Protected areas
- (4) National Park

165 Which one of the following enzymes contains 'Haem' as the prosthetic group?

- (1) Carbonic anhydrase
- (2) Succinate dehydrogenase
- (3) Catalase
- (4) RuBisCo

166 Given below are the stages in the life cycle of pteridophytes. Arrange the following stages in the correct sequence.

- A. Prothallus stage
- B. Meiosis in spore mother cells
- C. Fertilisation
- D. Formation of archegonia and antheridia in gametophyte.
- E. Transfer of antherozoids to the archegonia in presence of water.

Choose the **correct** answer from the options given below :

- (1) B, A, E, C, D
- (2) D, E, C, A, B
- (3) E, D, C, B, A
- (4) B, A, D, E, C

167 Which of following organisms *cannot* fix nitrogen?

- A. *Azotobacter*
- B. *Oscillatoria*
- C. *Anabaena*
- D. *Volvox*
- E. *Nostoc*

Choose the **correct** answer from the options given below:

- (1) D only
- (2) B only
- (3) E only
- (4) A only

168 While trying to find out the characteristic of a newly found animal, a researcher did the histology of adult animal and observed a cavity with presence of mesodermal tissue towards the body wall but no mesodermal tissue was observed towards the alimentary canal. What could be the possible coelome of that animal?

- (1) Pseudocoelomate
- (2) Schizocoelomate
- (3) Spongocoelomate
- (4) Acoelomate

169 Given below are two statements :

**Statement I :** In a floral formula  $\oplus$  stands for zygomorphic nature of the flower, and  $\underline{G}$  stands for inferior ovary.

**Statement II :** In a floral formula  $\oplus$  stands for actinomorphic nature of the flower and  $\underline{G}$  stands for superior ovary.

In the light of the above statements, choose the correct answer from the options given below:

- (1) Both Statement I and Statement II are incorrect
- (2) Statement I is correct but Statement II is incorrect
- (3) Statement I is incorrect but Statement II is correct
- (4) Both Statement I and Statement II are correct

170 Given below are two statements :

**Statement I :** The primary source of energy in an ecosystem is solar energy.

**Statement II :** The rate of production of organic matter during photosynthesis in an ecosystem is called net primary productivity (NPP).

In the light of the above statements, choose the most appropriate answer from the options given below :

- (1) Both statement I and statement II are incorrect
- (2) Statement I is correct but statement II is incorrect
- (3) Statement I is incorrect but statement II is correct
- (4) Both statement I and statement II are correct

171 Which of the following diagrams is correct with regard to the proximal (P) and distal (D) tubule of the Nephron.

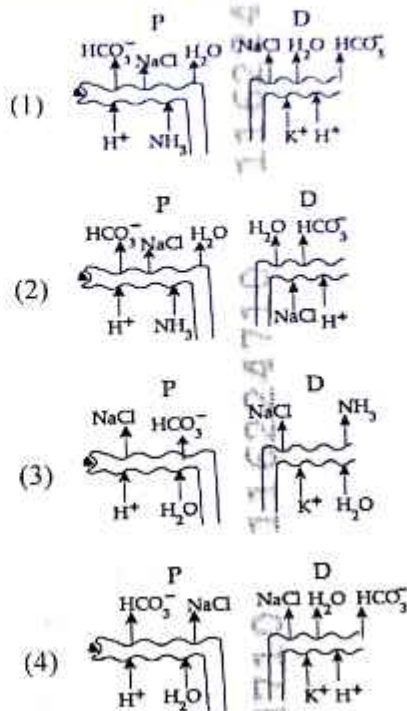

172 Streptokinase produced by bacterium *Streptococcus* is used for

- (1) Ethanol production
- (2) Liver disease treatment
- (3) Removing clots from blood vessels
- (4) Curd production

173 Cardiac activities of the heart are regulated by:

- A. Nodal tissue
- B. A special neural centre in the medulla oblongata
- C. Adrenal medullary hormones
- D. Adrenal cortical hormones

Choose the correct answer from the options given below :

- (1) A, B, C and D
- (2) A, C and D Only
- (3) A, B and D Only
- (4) A, B and C Only

[ Contd...

174 Given below are two statements : One is labelled as **Assertion (A)** and the other is labelled as **Reason (R)**.

**Assertion (A)** : A typical unfertilised, angiosperm embryo sac at maturity is 8 nucleate and 7-celled.

**Reason (R)** : The egg apparatus has 2 polar nuclei.

In the light of the above statements, choose the correct answer from the options given below:

- (1) Both **A** and **R** are true but **R** is **NOT** the correct explanation of **A**
- (2) **A** is true but **R** is false
- (3) **A** is false but **R** is true
- (4) Both **A** and **R** are true and **R** is the correct explanation of **A**

175 Find the statement that is **NOT** correct with regard to the structure of monocot stem.

- (1) Vascular bundles are scattered.
- (2) Vascular bundles are conjoint and closed.
- (3) Phloem parenchyma is absent.
- (4) Hypodermis is parenchymatous.

176 Given below are two statements : One is labelled as **Assertion (A)** and the other is labelled as **Reason (R)**.

**Assertion (A)** : Both wind and water pollinated flowers are not very colourful and do not produce nectar.

**Reason (R)** : The flowers produce enormous amount of pollen grains in wind and water pollinated flowers.

In the light of the above statements, choose the correct answer from the options given below:

- (1) Both **A** and **R** are true but **R** is **NOT** the correct explanation of **A**
- (2) **A** is true but **R** is false
- (3) **A** is false but **R** is true
- (4) Both **A** and **R** are true and **R** is the correct explanation of **A**

177 Neoplastic characteristics of cells refer to :

- A. A mass of proliferating cell
- B. Rapid growth of cells
- C. Invasion and damage to the surrounding tissue
- D. Those confined to original location

Choose the **correct** answer from the options given below:

- (1) A, B, C only
- (2) A, B, D only
- (3) B, C, D only
- (4) A, B only

178 The complex II of mitochondrial electron transport chain is also known as

- (1) Succinate dehydrogenase
- (2) Cytochrome c oxidase
- (3) NADH dehydrogenase
- (4) Cytochrome  $bc_1$

179 Polymerase chain reaction (PCR) amplifies DNA following the equation.

- (1)  $2^n$
- (2)  $2n + 1$
- (3)  $2N^2$
- (4)  $N^2$

180

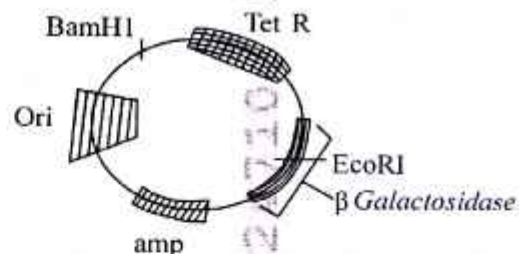

In the above represented plasmid an alien piece of DNA is inserted at EcoRI site. Which of the following strategies will be chosen to select the recombinant colonies?

- (1) Blue color colonies will be selected.
- (2) White color colonies will be selected.
- (3) Blue color colonies grown on ampicillin plates can be selected.
- (4) Using ampicillin & tetracyclin containing medium plate.

116225007

↑  
Test Booklet No.

Test Booklet Code

47

ENGLISH

NARMADA

Do not open this Test Booklet until you are asked to do so.

This Booklet contains 32 pages, including Rough Page.

**Important Instructions:**

1. The Answer Sheet is inside this Test Booklet. When you are directed to open the Test Booklet, take out the Answer Sheet and fill in the particulars on ORIGINAL Copy carefully with blue/black ball point pen only.
2. The test is of 3 hours duration and the Test Booklet contains 180 multiple-choice questions (four options with a single correct answer) from Physics, Chemistry and Biology (Botany and Zoology).
3. Wherever the symbols/constants are not mentioned, they are to be considered as per their standard meaning/value.
4. Each question carries 4 marks. For each correct response, the candidate will get 4 marks. For each incorrect response, one mark will be deducted from the total scores. The maximum marks are 720.
5. Use Blue/Black Ball Point Pen only for writing particulars on this page/markings responses on Answer Sheet.
6. Rough work is to be done in the space provided for this purpose in the Test Booklet only.
7. On completion of the test, the candidate must hand over the Answer Sheet (ORIGINAL and OFFICE Copy) to the Invigilator before leaving the Room/Hall. The candidates are allowed to take away this Test Booklet with them.
8. The CODE for this Booklet is "47". Make sure to enter this code in the OMR answer sheet.
9. The candidates should ensure that the Answer Sheet is not folded. Do not make any stray marks on the Answer Sheet. Do not write your Roll No. anywhere else except in the specified space in the Test Booklet/ Answer Sheet.
10. Use of white fluid for correction is NOT permissible on the Answer Sheet.
11. Each candidate must show on-demand his/her Admit Card to the Invigilator.
12. No candidate, without special permission of the centre Superintendent or Invigilator, would leave his/her seat.
13. The candidates should not leave the Examination Hall without handing over their Answer Sheet to the Invigilator on duty and sign (with time) the Attendance Sheet twice. Cases, where a candidate has not signed the Attendance Sheet second time, will be deemed not to have handed over the Answer Sheet and dealt with as an Unfair Means case.
14. Use of Electronic/Manual Calculator is prohibited.
15. The candidates are governed by all Rules and Regulations of the examination with regard to their conduct in the Examination Room/Hall. All cases of unfair means will be dealt with as per the Rules and Regulations of this examination along with Public Examinations (Prevention of unfair means act 2024).
16. No part of the Test Booklet and Answer Sheet shall be detached under any circumstances.
17. The candidates will write the Correct Test Booklet Code as given in the Test Booklet/Answer Sheet in the Attendance Sheet.
18. If a candidate marks more than one answers for a question in the OMR Sheet, it will be treated as incorrect and negative marking will be applicable.

- 1 The current passing through the battery in the given circuit, is:

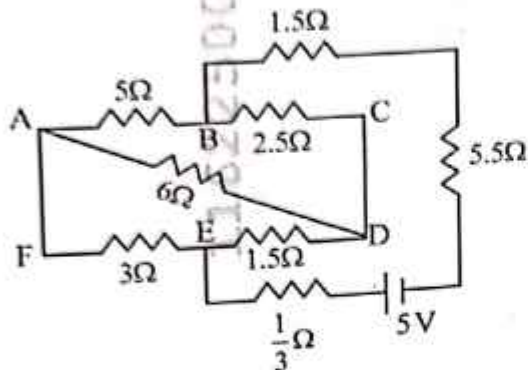

- (1) 1.5 A                      (2) 2.0 A  
(3) 0.5 A                      (4) 2.5 A

- 2 The electric field in a plane electromagnetic wave is given by

$$E_z = 60 \cos(5x + 1.5 \times 10^9 t) \text{ V/m}$$

Then expression for the corresponding magnetic field is (here subscripts denote the direction of the field):

- (1)  $B_y = 60 \sin(5x + 1.5 \times 10^9 t) \text{ T}$   
(2)  $B_y = 2 \times 10^{-7} \cos(5x + 1.5 \times 10^9 t) \text{ T}$   
(3)  $B_x = 2 \times 10^{-7} \cos(5x + 1.5 \times 10^9 t) \text{ T}$   
(4)  $B_z = 60 \cos(5x + 1.5 \times 10^9 t) \text{ T}$

- 3 A pipe open at both ends has a fundamental frequency  $f$  in air. The pipe is now dipped vertically in a water drum to half of its length. The fundamental frequency of the air column is now equal to:

- (1)  $2f$                       (2)  $\frac{f}{2}$   
(3)  $f$                       (4)  $\frac{3f}{2}$

4 An electron (mass  $9 \times 10^{-31} \text{ kg}$  and charge  $1.6 \times 10^{-19} \text{ C}$ ) moving with speed  $c/100$  ( $c = \text{speed of light}$ ) is injected into a magnetic field  $\vec{B}$  of magnitude  $9 \times 10^{-4} \text{ T}$  perpendicular to its direction of motion. We wish to apply a uniform electric field  $\vec{E}$  together with the magnetic field so that the electron does not deflect from its path. Then (speed of light  $c = 3 \times 10^8 \text{ ms}^{-1}$ )

- (1)  $\vec{E}$  is parallel to  $\vec{B}$  and its magnitude is  $27 \times 10^4 \text{ V m}^{-1}$   
(2)  $\vec{E}$  is perpendicular to  $\vec{B}$  and its magnitude is  $27 \times 10^4 \text{ V m}^{-1}$   
(3)  $\vec{E}$  is perpendicular to  $\vec{B}$  and its magnitude is  $27 \times 10^2 \text{ V m}^{-1}$   
(4)  $\vec{E}$  is parallel to  $\vec{B}$  and its magnitude is  $27 \times 10^2 \text{ V m}^{-1}$

- 5 In a certain camera, a combination of four similar thin convex lenses are arranged axially in contact. Then the power of the combination and the total magnification in comparison to the power ( $p$ ) and magnification ( $m$ ) for each lens will be, respectively

- (1)  $p^4$  and  $m^4$                       (2)  $4p$  and  $4m$   
(3)  $p^4$  and  $4m$                       (4)  $4p$  and  $m^4$

- 6 A 2 amp current is flowing through two different small circular copper coils having radii ratio 1:2. The ratio of their respective magnetic moments will be

- (1) 4:1                      (2) 1:4  
(3) 1:2                      (4) 2:1

- 7 A constant voltage of 50 V is maintained between the points A and B of the circuit shown in the figure. The current through the branch CD of the circuit is :

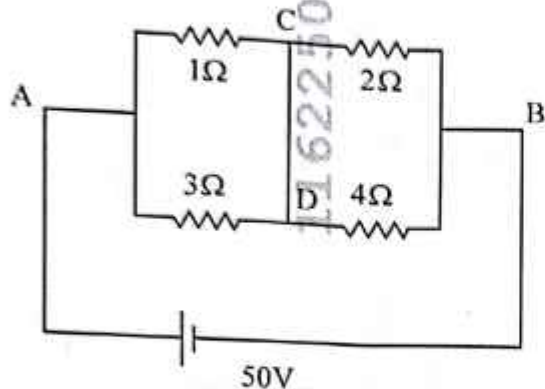

- (1) 3.0 A                      (2) 1.5 A  
 (3) 2.0 A                      (4) 2.5 A
- 8 Two gases A and B are filled at the same pressure in separate cylinders with movable pistons of radius  $r_A$  and  $r_B$ , respectively. On supplying an equal amount of heat to both the systems reversibly under constant pressure, the pistons of gas A and B are displaced by 16 cm and 9 cm, respectively. If the change in their internal energy is the same, then the ratio

$\frac{r_A}{r_B}$  is equal to

- (1)  $\frac{\sqrt{3}}{2}$                       (2)  $\frac{4}{3}$   
 (3)  $\frac{3}{4}$                       (4)  $\frac{2}{\sqrt{3}}$

- 9 A container has two chambers of volumes  $V_1 = 2$  litres and  $V_2 = 3$  litres separated by a partition made of a thermal insulator. The chambers contains  $n_1 = 5$  and  $n_2 = 4$  moles of ideal gas at pressures  $p_1 = 1$  atm and  $p_2 = 2$  atm, respectively. When the partition is removed, the mixture attains an equilibrium pressure of :

- (1) 1.8 atm                      (2) 1.3 atm  
 (3) 1.6 atm                      (4) 1.4 atm

- 10 The radius of Martian orbit around the Sun is about 4 times the radius of the orbit of Mercury. The Martian year is 687 Earth days. Then which of the following is the length of 1 year on Mercury.?

- (1) 124 earth days  
 (2) 88 earth days  
 (3) 225 earth days  
 (4) 172 earth days

- 11 To an ac power supply of 220 V at 50 Hz, a resistor of  $20\ \Omega$ , a capacitor of reactance  $25\ \Omega$  and an inductor of reactance  $45\ \Omega$  are connected in series. The corresponding current in the circuit and the phase angle between the current and the voltage is, respectively

- (1) 15.6 A and  $45^\circ$   
 (2) 7.8 A and  $30^\circ$   
 (3) 7.8 A and  $45^\circ$   
 (4) 15.6 A and  $30^\circ$

- 12 A wire of resistance R is cut into 8 equal pieces. From these pieces two equivalent resistances are made by adding four of these together in parallel. Then these two sets are added in series. The net effective resistance of the combination is :

- (1)  $\frac{R}{8}$                       (2)  $\frac{R}{64}$   
 (3)  $\frac{R}{32}$                       (4)  $\frac{R}{16}$

- 13 The output (Y) of the given logic implementation is similar to the output of an/a \_\_\_\_\_ gate.

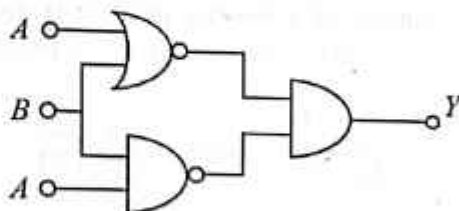

- (1) NOR                      (2) AND  
 (3) NAND                      (4) OR

14 Two identical charged conducting spheres A and B have their centres separated by a certain distance. Charge on each sphere is  $q$  and the force of repulsion between them is  $F$ . A third identical uncharged conducting sphere is brought in contact with sphere A first and then with B and finally removed from both. New force of repulsion between spheres A and B (Radii of A and B are negligible compared to the distance of separation so that for calculating force between them they can be considered as point charges) is best given as :

- (1)  $\frac{3F}{8}$  (2)  $\frac{3F}{5}$   
 (3)  $\frac{2F}{3}$  (4)  $\frac{F}{2}$

15 Consider the diameter of a spherical object being measured with the help of a Vernier callipers. Suppose its 10 Vernier Scale Divisions (V.S.D.) are equal to its 9 Main Scale Divisions (M.S.D.). The least division in the M.S. is 0.1 cm and the zero of V.S. is at  $x = 0.1$  cm when the jaws of Vernier callipers are closed.

If the main scale reading for the diameter is  $M = 5$  cm and the number of coinciding vernier division is 8, the measured diameter after zero error correction, is

- (1) 5.00 cm (2) 5.18 cm  
 (3) 5.08 cm (4) 4.98 cm

16 In some appropriate units, time ( $t$ ) and position ( $x$ ) relation of a moving particle is given by  $t = x^2 + x$ . The acceleration of the particle is

- (1)  $+\frac{2}{2x+1}$  (2)  $-\frac{2}{(x+2)^3}$   
 (3)  $-\frac{2}{(2x+1)^3}$  (4)  $+\frac{2}{(x+1)^3}$

17 Which of the following options represent the variation of photoelectric current with property of light shown on the x-axis?

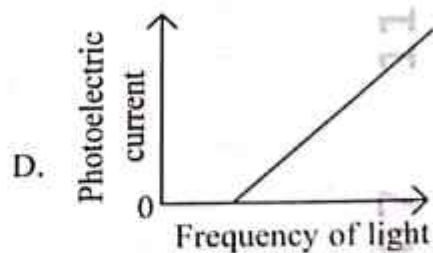
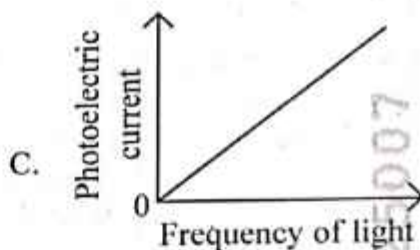
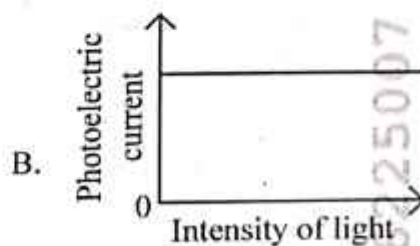
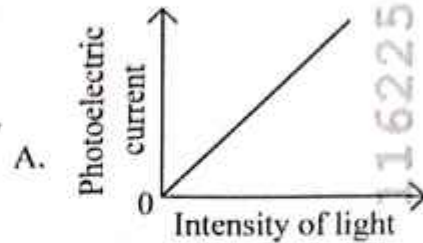

- (1) B and D  
 (2) A only  
 (3) A and C  
 (4) A and D

18 A particle of mass  $m$  is moving around the origin with a constant force  $F$  pulling it towards the origin. If Bohr model is used to describe its motion, the radius  $r$  of the  $n^{\text{th}}$  orbit and the particle's speed  $v$  in the orbit depend on  $n$  as

(1)  $r \propto n^{4/3}; v \propto n^{-1/3}$

(2)  $r \propto n^{1/3}; v \propto n^{1/3}$

(3)  $r \propto n^{1/3}; v \propto n^{2/3}$

(4)  $r \propto n^{2/3}; v \propto n^{1/3}$

19 A bob of heavy mass  $m$  is suspended by a light string of length  $l$ . The bob is given a horizontal velocity  $v_0$  as shown in figure. If the string gets slack at some point  $P$  making an angle  $\theta$  from the horizontal, the ratio of the speed  $v$  of the bob at point  $P$  to its initial speed  $v_0$  is:

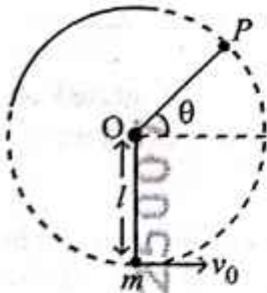

(1)  $\left(\frac{\sin \theta}{2+3 \sin \theta}\right)^{1/2}$

(2)  $(\sin \theta)^{1/2}$

(3)  $\left(\frac{\cos \theta}{2+3 \sin \theta}\right)^{1/2}$

(4)  $\left(\frac{\cos \theta}{2+3 \sin \theta}\right)^{1/2}$

20 A full wave rectifier circuit with diodes ( $D_1$ ) and ( $D_2$ ) is shown in the figure. If input supply voltage  $V_{in} = 220 \sin(100 \pi t)$  volt, then at  $t = 15 \text{ msec}$

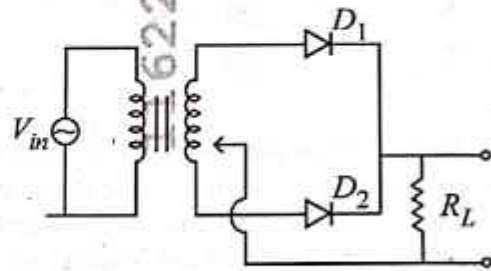

(1)  $D_1$  and  $D_2$  both are reverse biased

(2)  $D_1$  is forward biased,  $D_2$  is reverse biased

(3)  $D_1$  is reverse biased,  $D_2$  is forward biased

(4)  $D_1$  and  $D_2$  both are forward biased

21 A balloon is made of a material of surface tension  $S$  and its inflation outlet (from where gas is filled in it) has small area  $A$ . It is filled with a gas of density  $\rho$  and takes a spherical shape of radius  $R$ . When the gas is allowed to flow freely out of it, its radius  $r$  changes from  $R$  to 0 (zero) in time  $T$ . If the speed  $v(r)$  of gas coming out of the balloon depends on  $r$  as  $r^a$  and  $T \propto S^\alpha A^\beta \rho^\gamma R^\delta$  then

(1)  $a = \frac{1}{2}, \alpha = \frac{1}{2}, \beta = -\frac{1}{2}, \gamma = \frac{1}{2}, \delta = \frac{7}{2}$

(2)  $a = \frac{1}{2}, \alpha = \frac{1}{2}, \beta = -1, \gamma = +1, \delta = \frac{3}{2}$

(3)  $a = -\frac{1}{2}, \alpha = -\frac{1}{2}, \beta = -1, \gamma = -\frac{1}{2}, \delta = \frac{5}{2}$

(4)  $a = -\frac{1}{2}, \alpha = -\frac{1}{2}, \beta = -1, \gamma = \frac{1}{2}, \delta = \frac{7}{2}$

22 A microscope has an objective of focal length 2 cm, eyepiece of focal length 4 cm and the tube length of 40 cm. If the distance of distinct vision of eye is 25 cm, the magnification in the microscope is

- (1) 250  
(2) 100  
(3) 125  
(4) 150

23 Two identical point masses P and Q, suspended from two separate massless springs of spring constants  $k_1$  and  $k_2$ , respectively, oscillate vertically. If their maximum speeds are the same, the ratio ( $A_Q/A_P$ ) of the amplitude  $A_Q$  of mass Q to the amplitude  $A_P$  of mass P is:

- (1)  $\sqrt{\frac{k_1}{k_2}}$   
(2)  $\frac{k_2}{k_1}$   
(3)  $\frac{k_1}{k_2}$   
(4)  $\sqrt{\frac{k_2}{k_1}}$

24 A parallel plate capacitor made of circular plates is being charged such that the surface charge density on its plates is increasing at a constant rate with time. The magnetic field arising due to displacement current is :

- (1) zero between the plates and non-zero outside  
(2) zero at all places  
(3) constant between the plates and zero outside the plates  
(4) non-zero everywhere with maximum at the imaginary cylindrical surface connecting peripheries of the plates

25 An electric dipole with dipole moment  $1.5 \times 10^{-6} \text{ Cm}$  is aligned with the direction of a uniform electric field of magnitude  $4 \times 10^5 \text{ N/C}$ . The dipole is then rotated through an angle of  $60^\circ$  with respect to the electric field. The change in the potential energy of the dipole is :

- (1) 1.5 J  
(2) 0.8 J  
(3) 1.0 J  
(4) 1.2 J

26

There are two inclined surfaces of equal length ( $L$ ) and same angle of inclination  $45^\circ$  with the horizontal. One of them is rough and the other is perfectly smooth. A given body takes 2 times as much time to slide down on rough surface than on the smooth surface. The coefficient of kinetic friction ( $\mu_k$ ) between the object and the rough surface is close to

- (1) 0.75  
(2) 0.25  
(3) 0.40  
(4) 0.5

27

De-Broglie wavelength of an electron orbiting in the  $n = 2$  state of hydrogen atom is close to (Given Bohr radius =  $0.052 \text{ nm}$ )

- (1) 2.67 nm  
(2) 0.067 nm  
(3) 0.67 nm  
(4) 1.67 nm

28

The Sun rotates around its centre once in 27 days. What will be the period of revolution if the Sun were to expand to twice its present radius without any external influence? Assume the Sun to be a sphere of uniform density.

- (1) 108 days  
(2) 100 days  
(3) 105 days  
(4) 115 days

29

A physical quantity  $P$  is related to four observations  $a, b, c$  and  $d$  as follows:

$$P = a^3 b^2 / c \sqrt{d}$$

The percentage errors of measurement in  $a, b, c$  and  $d$  are 1%, 3%, 2%, and 4% respectively. The percentage error in the quantity  $P$  is

- (1) 15%  
(2) 10%  
(3) 2%  
(4) 13%

30

The plates of a parallel plate capacitor are separated by  $d$ . Two slabs of different dielectric

constant  $K_1$  and  $K_2$  with thickness  $\frac{3}{8}d$  and  $\frac{d}{2}$ , respectively are inserted in the capacitor. Due to this, the capacitance becomes two times larger than when there is nothing between the plates.

If  $K_1 = 1.25 K_2$ , the value of  $K_1$  is :

- (1) 1.33  
(2) 2.66  
(3) 2.33  
(4) 1.60

31 A ball of mass 0.5 kg is dropped from a height of 40 m. The ball hits the ground and rises to a height of 10 m. The impulse imparted to the ball during its collision with the ground is (Take  $g = 9.8 \text{ m/s}^2$ )

- (1) 84 NS  
(2) 21 NS  
(3) 7 NS  
(4) 0

32 Two cities X and Y are connected by a regular bus service with a bus leaving in either direction every T min. A girl is driving scooter with a speed of 60 km/h in the direction X to Y notices that a bus goes past her every 30 minutes in the direction of her motion, and every 10 minutes in the opposite direction. Choose the correct option for the period T of the bus service and the speed (assumed constant) of the buses.

- (1) 15 min, 120 km/h  
(2) 9 min, 40 km/h  
(3) 25 min, 100 km/h  
(4) 10 min, 90 km/h

33 An oxygen cylinder of volume 30 litre has 18.20 moles of oxygen. After some oxygen is withdrawn from the cylinder, its gauge pressure drops to 11 atmospheric pressure at temperature  $27^\circ\text{C}$ . The mass of the oxygen withdrawn from the cylinder is nearly equal to :

[Given,  $R = \frac{100}{12} \text{ J mol}^{-1}\text{K}^{-1}$ , and

molecular mass of  $\text{O}_2 = 32$ ,

1 atm pressure =  $1.01 \times 10^5 \text{ N/m}^2$ ]

- (1) 0.156 kg  
(2) 0.125 kg  
(3) 0.144 kg  
(4) 0.116 kg

34 AB is a part of an electrical circuit (see figure). The potential difference " $V_A - V_B$ ", at the instant when current  $i = 2 \text{ A}$  and is increasing at a rate of 1 amp / second is:



- (1) 10 volt  
(2) 5 volt  
(3) 6 volt  
(4) 9 volt

35

In an oscillating spring mass system, a spring is connected to a box filled with sand. As the box oscillates, sand leaks slowly out of the box vertically so that the average frequency  $\omega(t)$  and average amplitude  $A(t)$  of the system change with time  $t$ . Which one of the following options schematically depicts these changes correctly?

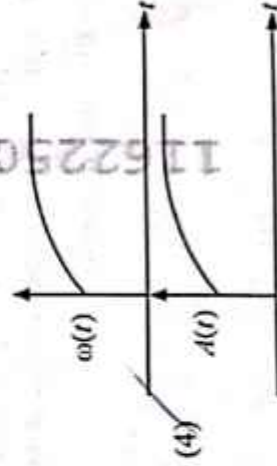
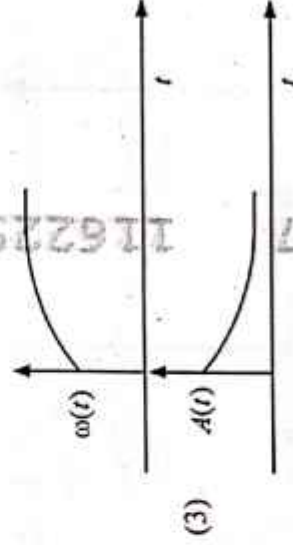
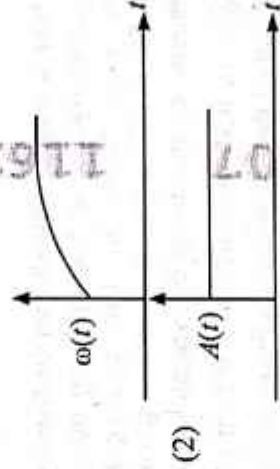
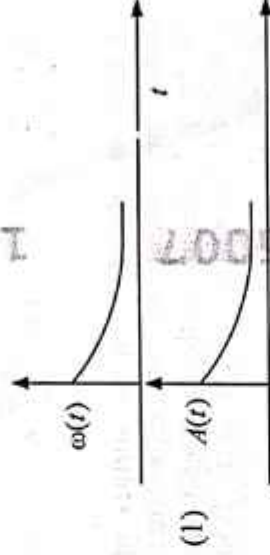

36. A model for quantized motion of an electron in a uniform magnetic field  $B$  states that the flux passing through the orbit of the electron is  $n(h/e)$  where  $n$  is an integer,  $h$  is Planck's constant and  $e$  is the magnitude of electron's charge. According to the model, the magnetic moment of an electron in its lowest energy state will be ( $m$  is the mass of the electron)

(1)  $\frac{heB}{2\pi m}$  (2)  $\frac{he}{\pi m}$

(3)  $\frac{he}{2\pi m}$  (4)  $\frac{heB}{\pi m}$

37. A body weighs 48 N on the surface of the earth. The gravitational force experienced by the body due to the earth at a height equal to one-third the radius of the earth from its surface is :

(1) 36 N (2) 16 N  
(3) 27 N (4) 32 N

38. Consider a water tank shown in the figure. It has one wall at  $x = L$  and can be taken to be very wide in the  $z$  direction. When filled with a liquid of surface tension  $S$  and density  $\rho$ , the liquid surface makes angle  $\theta_0$  ( $\theta_0 \ll 1$ ) with the  $x$ -axis at  $x = L$ . If  $y(x)$  is the height of the surface then the equation for  $y(x)$  is :

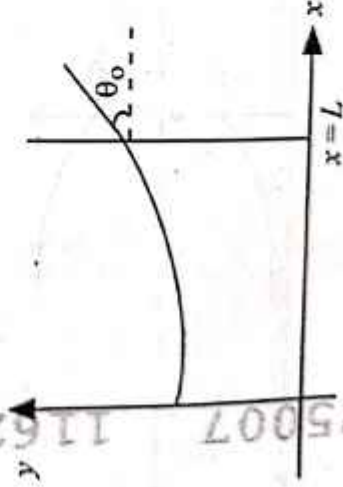

(take  $\theta(x) = \sin\theta(x) = \tan\theta(x) = \frac{dy}{dx}$ ,  $g$  is the acceleration due to gravity)

(1)  $\frac{dy}{dx} = \sqrt{\frac{\rho g}{S}}x$  (2)  $\frac{d^2y}{dx^2} = \frac{\rho g}{S}x$

(3)  $\frac{d^2y}{dx^2} = \frac{\rho g}{S}y$  (4)  $\frac{d^2y}{dx^2} = \sqrt{\frac{\rho g}{S}}$

47\_English ]

39

The intensity of transmitted light when a polaroid sheet, placed between two crossed polaroids at  $22.5^\circ$  from the polarization axis of one of the polaroid, is ( $I_0$  is the intensity of polarised light after passing through the first polaroid):

(1)  $\frac{I_0}{16}$  (2)  $\frac{I_0}{2}$

(3)  $\frac{I_0}{4}$  (4)  $\frac{I_0}{8}$

40. A photon and an electron (mass  $m$ ) have the same energy  $E$ . The ratio ( $\lambda_{\text{photon}}/\lambda_{\text{electron}}$ ) of their de Broglie wavelengths is: ( $c$  is the speed of light)

(1)  $\frac{1}{c}\sqrt{\frac{E}{2m}}$  (2)  $\sqrt{\frac{E}{2m}}$

(3)  $c\sqrt{2mE}$  (4)  $c\sqrt{\frac{2m}{E}}$

41. An unpolarized light beam travelling in air is incident on a medium of refractive index 1.73 at Brewster's angle. Then-

- (1) transmitted light is completely polarized with angle of refraction close to  $30^\circ$
- (2) reflected light is completely polarized and the angle of reflection is close to  $60^\circ$
- (3) reflected light is partially polarized and the angle of reflection is close to  $30^\circ$
- (4) both reflected and transmitted light are perfectly polarized with angles of reflection and refraction close to  $60^\circ$  and  $30^\circ$ , respectively.

42

A uniform rod of mass 20 kg and length 5 m leans against a smooth vertical wall making an angle of  $60^\circ$  with it. The other end rests on a rough horizontal floor. The friction force that the floor exerts on the rod is (take  $g = 10 \text{ m/s}^2$ )

(1)  $200\sqrt{3} \text{ N}$  (2) 100 N

(3)  $100\sqrt{3} \text{ N}$  (4) 200 N

- 43 Three identical heat conducting rods are connected in series as shown in the figure. The rods on the sides have thermal conductivity  $2K$  while that in the middle has thermal conductivity  $K$ . The left end of the combination is maintained at temperature  $3T$  and the right end at  $T$ . The rods are thermally insulated from outside. In steady state, temperature at the left junction is  $T_1$  and that at the right junction is  $T_2$ . The ratio  $T_1/T_2$  is

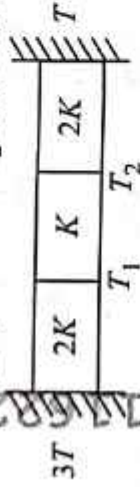

- (1)  $\frac{5}{4}$  (2)  $\frac{3}{2}$   
 (3)  $\frac{4}{3}$  (4)  $\frac{5}{3}$

- 44 The kinetic energies of two similar cars A and B are  $100\text{ J}$  and  $225\text{ J}$  respectively. On applying breaks, car A stops after  $1000\text{ m}$  and car B stops after  $1500\text{ m}$ . If  $F_A$  and  $F_B$  are the forces applied by the breaks on cars A and B, respectively, then the ratio  $F_A/F_B$  is

- (1)  $\frac{1}{2}$  (2)  $\frac{3}{2}$   
 (3)  $\frac{2}{3}$  (4)  $\frac{1}{3}$

- 45 A sphere of radius  $R$  is cut from a larger solid sphere of radius  $2R$  as shown in the figure. The ratio of the moment of inertia of the smaller sphere to that of the rest part of the sphere about the Y-axis is:

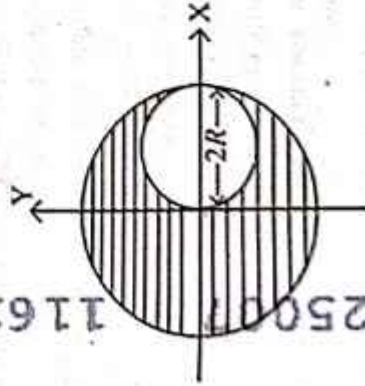

- (1)  $\frac{7}{8}$  (2)  $\frac{7}{8}$   
 (3)  $\frac{7}{40}$  (4)  $\frac{7}{57}$

- 46 If the molar conductivity ( $\Lambda_m$ ) of a  $0.050\text{ mol L}^{-1}$  solution of a monobasic weak acid is  $90\text{ S cm}^2\text{ mol}^{-1}$ , its extent (degree) of dissociation will be

[Assume  $\Lambda_+^\circ = 349.6\text{ S cm}^2\text{ mol}^{-1}$  and

$\Lambda_-^\circ = 50.4\text{ S cm}^2\text{ mol}^{-1}$ .]

- (1)  $0.215$  (2)  $0.115$   
 (3)  $0.125$  (4)  $0.225$

- 47 Given below are two statements:

**Statement I:** A hypothetical diatomic molecule with bond order zero is quite stable.

**Statement II:** As bond order increases, the bond length increases.

In the light of the above statements, choose the most appropriate answer from the options given below:

- (1) Statement I is false but Statement II is true  
 (2) Both Statement I and Statement II are true  
 (3) Both Statement I and Statement II are false  
 (4) Statement I is true but Statement II is false

- 48 The ratio of the wavelengths of the light absorbed by a Hydrogen atom when it undergoes  $n = 2 \rightarrow n = 3$  and  $n = 4 \rightarrow n = 6$  transitions, respectively, is

- (1)  $\frac{1}{4}$  (2)  $\frac{1}{9}$   
 (3)  $\frac{1}{16}$  (4)  $\frac{1}{6}$

49 The correct order of the wavelength of light absorbed by the following complexes is,

- A.  $[\text{Co}(\text{NH}_3)_6]^{3+}$  B.  $[\text{Co}(\text{CN})_6]^{3-}$   
 C.  $[\text{Cu}(\text{H}_2\text{O})_4]^{2+}$  D.  $[\text{Ti}(\text{H}_2\text{O})_6]^{3+}$

Choose the correct answer from the options given below:

- (1)  $C < A < D < B$   
 (2)  $B < D < A < C$   
 (3)  $B < A < D < C$   
 (4)  $C < D < A < B$

50 If the rate constant of a reaction is  $0.03 \text{ s}^{-1}$ , how much time does it take for  $7.2 \text{ mol L}^{-1}$  concentration of the reactant to get reduced to  $0.9 \text{ mol L}^{-1}$ ?

(Given:  $\log 2 = 0.301$ )

- (1) 21.0 s  
 (2) 69.3 s  
 (3) 23.1 s  
 (4) 210 s

51 Match List I with List II

List I	List II
(1) Crude oil in petroleum industry	(Method of Separation) Distillation under reduced pressure
(2) $\text{NH}_2$	I. Steam distillation
(3) Glycerol from spent-lye	II. Fractional distillation
(4) Aniline - water	III. Simple distillation
	IV. Steam distillation

Choose the correct answer from the options given below:

- (1) A-III, B-IV, C-II, D-I  
 (2) A-IV, B-III, C-I, D-II  
 (3) A-IV, B-III, C-II, D-I  
 (4) A-III, B-IV, C-I, D-II

47\_English ]

10

52 The major product of the following reaction is:

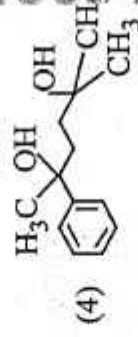
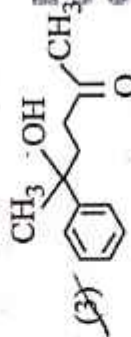
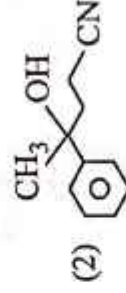
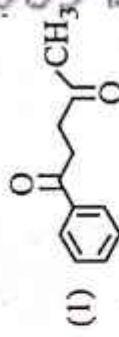

53 Which one of the following compounds can exist as cis-trans isomers?

- (1) 1,2-Dimethylcyclohexane  
 (2) Pent-1-ene  
 (3) 2-Methylhex-2-ene  
 (4) 1,1-Dimethylcyclopropane

54 Among the following, choose the ones with equal number of atoms.

- A. 212 g of  $\text{Na}_2\text{CO}_3$  (s) [molar mass = 106 g]  
 B. 248 g of  $\text{Na}_2\text{O}$  (s) [molar mass = 62 g]  
 C. 240 g of  $\text{NaOH}$  (s) [molar mass = 40 g]  
 D. 12 g of  $\text{H}_2$  (g) [molar mass = 2 g]  
 E. 220 g of  $\text{CO}_2$  (g) [molar mass = 44 g]

Choose the correct answer from the options given below:

- (1) B, D, and E only  
 (2) A, B, and C only  
 (3) A, B, and D only  
 (4) B, C, and D only

[ Contd...

55 Among the given compounds I-III, the correct order of bond dissociation energy of C-H bond marked with \* is :

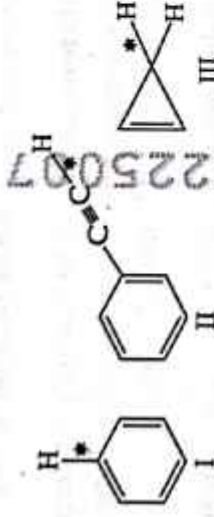

- (1) II > III > I  
 (2) II > I > III  
~~(3) I > II > III~~  
 (4) III > II > I

56 The standard heat of formation, in kcal/mol of  $Ba^{2+}$  is :

[Given : standard heat of formation of  $SO_4^{2-}$  ion (aq) = - 216 kcal/mol, standard heat of crystallisation of

$BaSO_4(s)$  = - 4.5 kcal/mol, standard heat of formation of  $BaSO_4(s)$  = - 349 kcal/mol]

- (1) + 220.5 (2) 128.5  
~~(3) - 133.0~~ (4) 133.0

57 Consider the following compounds :



The oxidation states of the underlined elements in them are, respectively

- (1) +4, -4, and +6  
~~(2) +1, -1, and +6~~  
 (3) +2, -2, and +6  
 (4) +1, -2, and +4

58

Out of the following complex compounds, which of the compound will be having the minimum conductance in solution?

- ~~(1)  $[Co(NH_3)_5Cl]Cl$~~   
 (2)  $[Co(NH_3)_3Cl_3]$   
 (3)  $[Co(NH_3)_4Cl_2]$   
 (4)  $[Co(NH_3)_6]Cl_3$

59 Which one of the following reactions does NOT give benzene as the product ?

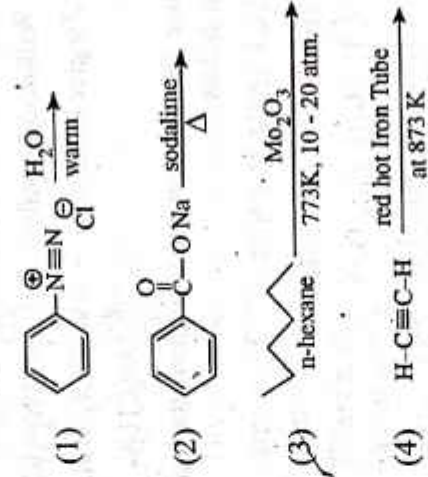

60 Which of the following are paramagnetic?

- A.  $[NiCl_4]^{2-}$  B.  $Ni(CO)_4$   
 C.  $[Ni(CN)_4]^{2-}$  D.  $[Ni(H_2O)_6]^{2+}$   
 E.  $Ni(PPh_3)_4$

Choose the correct answer from the options given below:

- (1) A, D and E only  
~~(2) A and C only~~  
 (3) B and E only  
 (4) A and D only

61 Which one of the following compounds does not decolourize bromine water?

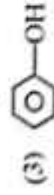

62 Match List - I with List - II

List-I

- A. Haber process  
 B. Wacker oxidation  
 C. Wilkinson catalyst  
 D. Ziegler catalyst

List-II

- I. Fe catalyst  
 II.  $\text{PdCl}_2$   
 III.  $(\text{PPh}_3)_3\text{RhCl}$   
 IV.  $\text{TiCl}_4$  with  $\text{Al}(\text{CH}_3)_3$

Choose the correct answer from the options given below :

- (1) A-I, B-IV, C-III, D-II  
 (2) A-I, B-II, C-IV, D-III  
 (3) A-II, B-III, C-I, D-IV  
 (4) A-I, B-II, C-III, D-IV

63 Match List I with List II.

List I

- (Name of Vitamin)  
 A. Vitamin B<sub>12</sub>  
 B. Vitamin D  
 C. Vitamin B<sub>2</sub>  
 D. Vitamin B<sub>6</sub>

List II

- (Deficiency disease)  
 I. Cheilosis  
 II. Convulsions  
 III. Rickets  
 IV. Pernicious anaemia

Choose the correct answer from the options given below :

- (1) A-IV, B-III, C-II, D-I  
 (2) A-I, B-III, C-II, D-IV  
 (3) A-IV, B-III, C-I, D-II  
 (4) A-II, B-III, C-I, D-IV

47\_English ]

64

Given below are two statements :

**Statement I :** Ferromagnetism is considered as an extreme form of paramagnetism.

**Statement II :** The number of unpaired electrons in a  $\text{Cr}^{2+}$  ion ( $Z = 24$ ) is the same as that of a  $\text{Nd}^{3+}$  ion ( $Z = 60$ ).

In the light of the above statements, choose the correct answer from the options given below :

- (1) Statement I is false but Statement II is true  
 (2) Both Statement I and Statement II are true  
 (3) Both Statement I and Statement II are false  
 (4) Statement I is true but Statement II is false

65 If the half-life ( $t_{1/2}$ ) for a first order reaction is 1 minute, then the time required for 99.9% completion of the reaction is closest to :

- (1) 10 minutes (2) 2 minutes  
 (3) 4 minutes (4) 5 minutes

66 The correct order of decreasing basic strength of the given amines is :

- (1) benzenamine > ethanamine > N-methylaniline > N-ethylethanamine  
 (2) N-methylaniline > benzenamine > ethanamine > N-ethylethanamine  
 (3) N-ethylethanamine > ethanamine > benzenamine > N-methylaniline  
 (4) N-ethylethanamine > ethanamine > N-methylaniline > benzenamine

12

[ Contd.-

67 Match List I with List II

List I (Ion)	List II (Group Number in Cation Analysis)
A. $\text{Co}^{2+}$	I. Group-I
B. $\text{Mg}^{2+}$	II. Group-III
C. $\text{Pb}^{2+}$	III. Group-IV
D. $\text{Al}^{3+}$	IV. Group-VI

Choose the correct answer from the options given below :

- (1) A-III, B-II, C-I, D-IV  
 (2) A-III, B-IV, C-II, D-I  
 (3) A-III, B-IV, C-I, D-II  
 (4) A-III, B-II, C-IV, D-I

68 Phosphoric acid ionizes in three steps with their ionization constant values

$K_{a_1}$ ,  $K_{a_2}$  and  $K_{a_3}$ , respectively,

while K is the overall ionization constant.

Which of the following statements are true?

- A.  $\log K = \log K_{a_1} + \log K_{a_2} + \log K_{a_3}$   
 B.  $\text{H}_3\text{PO}_4$  is a stronger acid than  $\text{H}_2\text{PO}_4^-$  and  $\text{HPO}_4^{2-}$ .  
 C.  $K_{a_1} > K_{a_2} > K_{a_3}$   
 D.  $K_{a_1} = \frac{K_{a_3} + K_{a_2}}{2}$

Choose the correct answer from the options given below:

- (1) A, B and C only  
 (2) A and B only  
 (3) A and C only  
 (4) B, C and D only

69 Which of the following statements are true?

- A. Unlike Ga that has a very high melting point, Cs has a very low melting point.  
 B. On Pauling scale, the electronegativity values of N and Cl are not the same.  
 C. Ar,  $\text{K}^+$ ,  $\text{Cl}^-$ ,  $\text{Ca}^{2+}$ , and  $\text{S}^{2-}$  are all isoelectronic species.  
 D. The correct order of the first ionization enthalpies of Na, Mg, Al, and Si is  $\text{Si} > \text{Al} > \text{Mg} > \text{Na}$ .  
 E. The atomic radius of Cs is greater than that of Li and Rb.

Choose the correct answer from the options given below :

- (1) A, C and E only  
 (2) A, B and E only  
 (3) C and E only  
 (4) C and D only

70 Given below are two statements :

**Statement I** : Like nitrogen that can form ammonia, arsenic can form arsine.

**Statement II** : Antimony cannot form antimony pentoxide.

In the light of the above statements, choose the most appropriate answer from the options given below:

- (1) Statement I is incorrect but Statement II is correct  
 (2) Both Statement I and Statement II are correct  
 (3) Both Statement I and Statement II are incorrect  
 (4) Statement I is correct but Statement II is incorrect

71 Which of the following aqueous solution will exhibit highest boiling point?

- (1) 0.015M  $\text{C}_6\text{H}_{12}\text{O}_6$   
 (2) 0.01M Urea  
 (3) 0.01M  $\text{KNO}_3$   
 (4) 0.01M  $\text{Na}_2\text{SO}_4$

72

Given below are two statements :

**Statement I :** Benzenediazonium salt is prepared by the reaction of aniline with nitrous acid at 273 - 278 K. It decomposes easily in the dry state.

**Statement II :** Insertion of iodine into the benzene ring is difficult and hence iodobenzene is prepared through the reaction of benzenediazonium salt with KI.

In the light of the above statements, choose the most appropriate answer from the options given below :

- (1) Statement I is incorrect but Statement II is correct
- (2) Both Statement I and Statement II are correct
- (3) Both Statement I and Statement II are incorrect
- (4) Statement I is correct but Statement II is incorrect

73

Identify the suitable reagent for the following conversion.



- (1)  $\text{H}_2 / \text{Pd-BaSO}_4$
- (2) (i)  $\text{LiAlH}_4$ , (ii)  $\text{H}^+/\text{H}_2\text{O}$
- (3) (i)  $\text{AlH}(\text{iBu})_2$ , (ii)  $\text{H}_2\text{O}$
- (4) (i)  $\text{NaBH}_4$ , (ii)  $\text{H}^+/\text{H}_2\text{O}$

74

Given below are two statements : one is labelled as Assertion (A) and the other is labelled as Reason (R).

**Assertion (A) :** I undergoes  $\text{S}_{\text{N}}2$  reaction faster than Cl.

**Reason (R) :** Iodine is a better leaving group because of its large size.

In the light of the above statements, choose the correct answer from the options given below :

- (1) A is false but R is true
- (2) Both A and R are true and R is the correct explanation of A
- (3) Both A and R are true and R is not the correct explanation of A
- (4) A is true but R is false

47\_English I

75

The correct order of decreasing acidity of the following aliphatic acids is :

- (1)  $\text{HCOOH} > (\text{CH}_3)_3\text{CCOOH} > (\text{CH}_3)_2\text{CHCOOH} > \text{CH}_3\text{COOH}$
- (2)  $(\text{CH}_3)_3\text{CCOOH} > (\text{CH}_3)_2\text{CHCOOH} > \text{CH}_3\text{COOH} > \text{HCOOH}$
- (3)  $\text{CH}_3\text{COOH} > (\text{CH}_3)_2\text{CHCOOH} > (\text{CH}_3)_3\text{CCOOH} > \text{HCOOH}$
- (4)  $\text{HCOOH} > \text{CH}_3\text{COOH} > (\text{CH}_3)_2\text{CHCOOH} > (\text{CH}_3)_3\text{CCOOH}$

76

Which one of the following reactions does NOT belong to "Lassaigne's test"?

- (1)  $2\text{CuO} \equiv \text{C} \xrightarrow{\Delta} 2\text{Cu} + \text{CO}_2$
- (2)  $\text{Na} + \text{C}_2\text{H}_5\text{N} \xrightarrow{\Delta} \text{NaCN}$
- (3)  $2\text{Na} + \text{S} \xrightarrow{\Delta} \text{Na}_2\text{S}$
- (4)  $\text{Na} + \text{X} \xrightarrow{\Delta} + \text{NaX}$

77

How many products (including stereoisomers) are expected from monochlorination of the following compound?



- (1) 6
- (2) 2
- (3) 3
- (4) 5

78

Sugar 'X'

A. is found in honey.

B. is a keto sugar.

C. exists in  $\alpha$  and  $\beta$  - anomeric forms.

D. is laevorotatory.

'X' is :

- (1) Sucrose
- (2) D-Glucose
- (3) D-Fructose
- (4) Maltose

14

[ Contd... ]

79 Dalton's Atomic theory could not explain which of the following?

- (1) Law of gaseous volume  
 (2) Law of conservation of mass  
 (3) Law of constant proportion  
 (4) Law of multiple proportion

80 Higher yield of NO in



$[\Delta H \text{ of the reaction} = +180.7 \text{ kJ mol}^{-1}]$

- A. higher temperature  
 B. lower temperature

- C. higher concentration of  $\text{N}_2$   
 D. higher concentration of  $\text{O}_2$

Choose the correct answer from the options given below:

- (1) A, C, D only (2) A, D only  
 (3) B, C only (4) B, C, D only

81 Match List - I with List - II

List-I

- A.  $\text{XeO}_3$   
 B.  $\text{XeF}_2$   
 C.  $\text{XeOF}_4$

List-II

- I.  $sp^3d$ ; linear  
 II.  $sp^3$ ; pyramidal  
 III.  $sp^3d^3$ ; distorted octahedral  
 D.  $\text{XeF}_6$  IV.  $sp^3d^2$ ; square pyramidal

Choose the correct answer from the options given below :

- (1) A-IV, B-J, C-I, D-III  
 (2) A-II, B-I, C-IV, D-III  
 (3) A-II, B-I, C-III, D-IV  
 (4) A-IV, B-II, C-III, D-I

82

Match List - I with List - II

List-I

- (Example)  
 A. Humidity  
 B. Alloys  
 C. Amalgams  
 D. Smoke

List-II

- (Type of Solution)  
 I. Solid in solid  
 II. Liquid in gas  
 III. Solid in gas  
 IV. Liquid in solid

Choose the correct answer from the options given below :

- (1) A-III, B-II, C-I, D-IV  
 (2) A-II, B-IV, C-I, D-III  
 (3) A-II, B-I, C-IV, D-III  
 (4) A-III, B-I, C-IV, D-II

83 Energy and radius of first Bohr orbit of  $\text{He}^+$  and  $\text{Li}^{2+}$  are

[Given  $R_H = 2.18 \times 10^{-18} \text{ J}$ ,  $a_0 = 52.9 \text{ pm}$ ]

- (1)  $E_n(\text{Li}^{2+}) = -8.72 \times 10^{-16} \text{ J}$ ;  
 $r_n(\text{Li}^{2+}) = 17.6 \text{ pm}$   
 $E_n(\text{He}^+) = -19.62 \times 10^{-16} \text{ J}$ ;  
 $r_n(\text{He}^+) = 17.6 \text{ pm}$   
 (2)  $E_n(\text{Li}^{2+}) = -19.62 \times 10^{-18} \text{ J}$ ;  
 $r_n(\text{Li}^{2+}) = 17.6 \text{ pm}$   
 $E_n(\text{He}^+) = -8.72 \times 10^{-18} \text{ J}$ ;  
 $r_n(\text{He}^+) = 26.4 \text{ pm}$   
 (3)  $E_n(\text{Li}^{2+}) = -8.72 \times 10^{-18} \text{ J}$ ;  
 $r_n(\text{Li}^{2+}) = 26.4 \text{ pm}$   
 $E_n(\text{He}^+) = -19.62 \times 10^{-18} \text{ J}$ ;  
 $r_n(\text{He}^+) = 17.6 \text{ pm}$   
 (4)  $E_n(\text{Li}^{2+}) = -19.62 \times 10^{-16} \text{ J}$ ;  
 $r_n(\text{Li}^{2+}) = 17.6 \text{ pm}$   
 $E_n(\text{He}^+) = -8.72 \times 10^{-16} \text{ J}$ ;  
 $r_n(\text{He}^+) = 26.4 \text{ pm}$

84

Which among the following electronic configurations belong to main group elements?

- A.  $[\text{Ne}]3s^1$  B.  $[\text{Ar}]3d^3 4s^2$   
 C.  $[\text{Kr}]4d^{10} 5s^2 5p^5$  D.  $[\text{Ar}]3d^{10} 4s^1$   
 E.  $[\text{Rn}]5f^0 6d^2 7s^2$

Choose the correct answer from the option given below :

- (1) A, C and D only (2) B and E only  
 (3) A and C only (4) D and E only

- 85  $C(s) + 2H_2(g) \rightarrow CH_4(g); \Delta H = -74.8 \text{ kJ mol}^{-1}$   
Which of the following diagrams gives an accurate representation of the above reaction?  
[R  $\rightarrow$  reactants; P  $\rightarrow$  products]

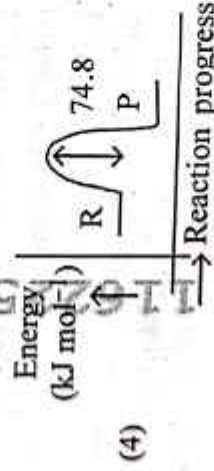
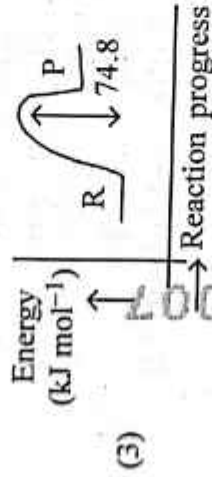
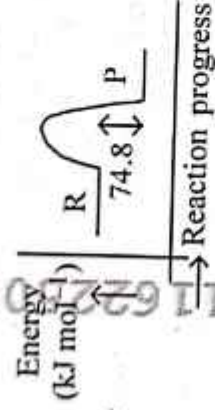
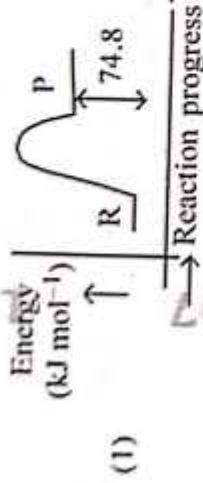

- 86 Predict the major product 'P' in the following sequence of reactions -

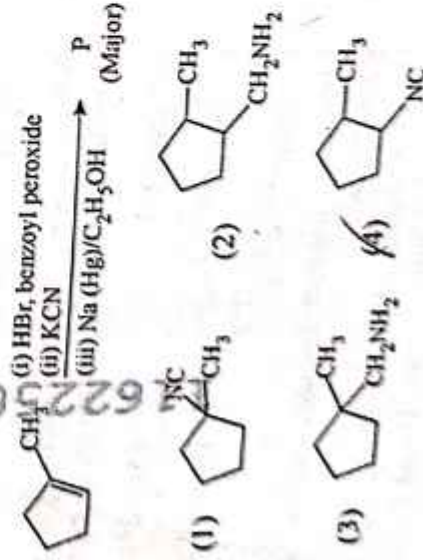

47\_English I

- 87 Identify the correct orders against the property mentioned

- A.  $H_2O > NH_3 > CHCl_3$  - dipole moment  
B.  $XeF_4 > XeO_3 > XeF_2$  - number of lone pairs on central atom  
C.  $O-H > C-H > N-O$  - bond length  
D.  $N_2 > O_2 > H_2$  - bond enthalpy

Choose the correct answer from the options given below :

- (1) B, C only (2) A, D only  
(3) B, D only (4) A, C only

- 88 Total number of possible isomers (both structural as well as stereoisomers) of cyclic ethers of molecular formula  $C_4H_8O$  is :

- (1) 11 (2) 6  
(3) 8 (4) 10

- 89 For the reaction  $A(g) \rightleftharpoons 2B(g)$ , the backward reaction rate constant is higher than the forward reaction rate constant by a factor of 2500, at 1000 K.

[Given :  $R = 0.0831 \text{ L atm mol}^{-1}K^{-1}$ ]

$K_p$  for the reaction at 1000 K is

- (1) 0.021 (2) 83.1  
(3)  $2.077 \times 10^5$  (4) 0.033

- 90 5 moles of liquid X and 10 moles of liquid Y make a solution having a vapour pressure of 70 torr. The vapour pressures of pure X and Y are 63 torr and 78 torr respectively. Which of the following is true regarding the described solution?

- (1) The solution has volume greater than the sum of individual volumes.  
(2) The solution shows positive deviation.  
(3) The solution shows negative deviation.  
(4) The solution is ideal.

91 Which of the following is the unit of productivity of an Ecosystem?

- (1)  $(\text{KCal m}^{-2})\text{yr}^{-1}$   
(2)  $\text{gm}^{-2}$   
(3)  $\text{KCal m}^{-2}$   
(4)  $\text{KCal m}^{-3}$

92 The first menstruation is called :

- (1) Ovulation  
(2) Menopause  
(3) Menarche  
(4) Diapause

93 Given below are two statements : one is labelled as Assertion (A) and the other is labelled as Reason (R).

Assertion (A) : All vertebrates are chordates but all chordates are not vertebrate.

Reason (R) : The members of subphylum vertebrata possess notochord during the embryonic period, the notochord is replaced by a cartilaginous or bony vertebral column in adults.

In the light of the above statements, choose the correct answer from the options given below :

- (1) A is false but R is true  
(2) Both A and R are true and R is the correct explanation of A  
(3) Both A and R are true but R is not the correct explanation of A  
(4) A is true but R is false

94 Genes R and Y follow independent assortment. If RRYy produce round/yellow seeds and rryy produce wrinkled green seeds, what will be the phenotypic ratio of the F<sub>2</sub> generation?

- (1) Phenotypic ratio - 9 : 7  
(2) Phenotypic ratio - 1 : 2 : 1  
(3) Phenotypic ratio - 3 : 1  
(4) Phenotypic ratio - 9 : 3 : 3 : 1

95

Given below are two statements :

Statement I : The DNA fragments extracted from gel electrophoresis can be used in construction of recombinant DNA.

Statement II : Smaller size DNA fragments are observed near anode while larger fragments are found near the wells in an agarose gel.

In the light of the above statements, choose the most appropriate answer from the options given below :

- (1) Statement I is incorrect but statement II is correct  
(2) Both statement I and statement II are correct  
(3) Both statement I and statement II are incorrect  
(4) Statement I is correct but statement II is incorrect

96 What is the main function of the spindle fibers during mitosis ?

- (1) To regulate cell growth  
(2) To separate the chromosomes  
(3) To synthesize new DNA  
(4) To repair damaged DNA

97 How many meiotic and mitotic divisions need to occur for the development of a mature female gametophyte from the megaspore mother cell in an angiosperm plant?

- (1) No Meiosis and 2 Mitosis  
(2) 2 Meiosis and 3 Mitosis  
(3) 1 Meiosis and 2 Mitosis  
(4) 1 Meiosis and 3 Mitosis

98 Identify the statement that is NOT correct.

- (1) Constant region of heavy and light chains are located at C-terminus of antibody molecules.  
(2) Each antibody has two light and two heavy chains.  
(3) The heavy and light chains are held together by disulfide bonds.  
(4) Antigen binding site is located at C-terminal region of antibody molecules.

99 Consider the following :

- A. The reductive division for the human female gametogenesis starts earlier than that of the male gametogenesis.
- B. The gap between the first meiotic division and the second meiotic division is much shorter for males compared to females.
- C. The first polar body is associated with the formation of the primary oocyte.
- D. Luteinizing Hormone (LH) surge leads to disintegration of the endometrium and onset of menstrual bleeding.

Choose the **correct** answer from the options given below:

- (1) B and C are true
- (2) A and B are true
- (3) A and C are true
- (4) B and D are true

100 Given below are two statements : One is labelled as **Assertion (A)** and the other is labelled as **Reason (R)**.

**Assertion (A)** : Cells of the tapetum possess dense cytoplasm and generally have more than one nucleus.

**Reason (R)** : Presence of more than one nucleus in the tapetum increases the efficiency of nourishing the developing microspore mother cells.

In light of the above statements, choose the **most appropriate** answer from the options given below:

- (1) A is false but R is true
- (2) Both A and R are true and R is the correct explanation of A
- (3) Both A and R are true but R is **NOT** the correct explanation of A
- (4) A is true but R is false

101

The blue and white selectable markers have been developed which differentiate recombinant colonies from non-recombinant colonies on the basis of their ability to produce colour in the presence of a chromogenic substrate.

Given below are two statements about this method:

**Statement I** : The blue coloured colonies have DNA insert in the plasmid and they are identified as recombinant colonies.

**Statement II** : The colonies without blue colour have DNA insert in the plasmid and are identified as recombinant colonies.

In the light of the above statements, choose the **most appropriate** answer from the options given below :

- (1) Statement I is incorrect but Statement II is correct
- (2) Both Statement I and Statement II are correct
- (3) Both Statement I and Statement II are incorrect
- (4) Statement I is correct but Statement II is incorrect

102

In bryophytes, the gemmae help in which one of the following?

- (1) Gaseous exchange.
- (2) Sexual reproduction
- (3) Asexual reproduction
- (4) Nutrient absorption

103 Match List I with List II.

List I List II

- A. Adenosine I. Nitrogen base
- B. Adenylic acid II. Nucleotide
- C. Adenine III. Nucleoside
- D. Alanine IV. Amino acid

Choose the option with all correct matches.

- (1) A-II, B-III, C-IV, D-I
- (2) A-III, B-IV, C-II, D-I
- (3) A-III, B-II, C-IV, D-I
- (4) A-III, B-II, C-I, D-IV

- 104 With the help of given pedigree, find out the probability for the birth of a child having no disease and being a carrier (has the disease mutation, in one allele of the gene) in F<sub>3</sub> generation.

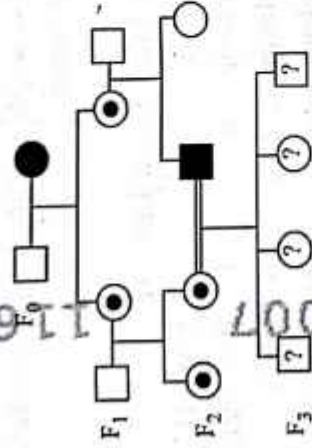

- Unaffected male
- Affected male
- Carrier female
- Unaffected female
- Affected female

- (1) Zero ~~(2) 1/4~~  
 (3) 1/20 (4) 1/8

- 105 Consider the following statements regarding function of adrenal medullary hormones :

- A. It causes pupillary constriction
- B. It is a hyperglycemic hormone
- C. It causes piloerection
- D. It increases strength of heart contraction

Choose the correct answer from the options given below :

- (1) D Only
- (2) C and D Only
- (3) B, C and D Only
- (4) A, C and D Only

- 106 Which of the following is an example of a zygomorphic flower?

- (1) X Chilli
- (2) Petunia
- (3) Y Datura
- (4) Pea

- 107 Who proposed that the genetic code for amino acids should be made up of three nucleotides?

- (1) Franklin Stahl
- (2) George Gamow
- (3) Francis Crick
- (4) Jacque Monod

- 108 Given below are two statements :

**Statement I :** In ecosystem, there is unidirectional flow of energy of sun from producers to consumers.

**Statement II :** Ecosystems are exempted from 2<sup>nd</sup> law of thermodynamics.

In the light of the above statements, choose the most appropriate answer from the options given below :

- (1) Statement I is incorrect but statement II is correct
- (2) Both statement I and statement II are correct
- (3) Both statement I and statement II are incorrect
- (4) Statement I is correct but statement II is incorrect

- 109 Sweet potato and potato represent a certain type of evolution. Select the correct combination of terms to explain the evolution.

- (1) Analogy, divergent
- (2) Analogy, convergent
- (3) Homology, divergent
- (4) Homology, convergent

- 110 All living members of the class Cyclostomata are:

- (1) Ectoparasite
- (2) Free living
- (3) Endoparasite
- (4) Symbiotic

- 111 Histones are enriched with -

- (1) Phenylalanine & Arginine
- (2) Lysine & Arginine
- (3) Leucine & Lysine
- (4) Phenylalanine & Leucine

112 Which one of the following equations represents the Verhulst-Pearl Logistic Growth of population?

$$(1) \frac{dN}{dt} = N \left( \frac{r}{K} \left( \frac{K-N}{N} \right) \right)$$

$$(2) \frac{dN}{dt} = r \left( \frac{K-N}{K} \right)$$

$$(3) \frac{dN}{dt} = rN \left( \frac{K-N}{K} \right)$$

$$(4) \frac{dN}{dt} = rN \left( \frac{N-K}{N} \right)$$

113 Given below are two statements : one is labelled as Assertion (A) and the other is labelled as Reason (R).

**Assertion (A) :** The primary function of the Golgi apparatus is to package the materials made by the endoplasmic reticulum and deliver it to intracellular targets and outside the cell.

**Reason (R) :** Vesicles containing materials made by the endoplasmic reticulum fuse with the cis face of the Golgi apparatus, and they are modified and released from the trans face of the Golgi apparatus.

In the light of the above statements, choose the correct answer from the options given below :

- (1) A is false but R is true
- (2) Both A and R are true and R is the correct explanation of A
- (3) Both A and R are true but R is not the correct explanation of A
- (4) A is true but R is false

114 Which of the following statements about RuBisCO is true?

- (1) It catalyzes the carboxylation of RuBP.
- (2) It is active only in the dark.
- (3) It has higher affinity for oxygen than carbon dioxide.
- (4) It is an enzyme involved in the photolysis of water.

115 Match List - I with List - II.

List - I

- A. Progesterone
- B. Relaxin
- C. Melanocyte stimulating hormone
- D. Catecholamines

List - II

- I. Pars intermedia
- II. Ovary
- III. Adrenal Medulla
- IV. Corpus luteum

Choose the correct answer from the options given below :

- (1) A-III, B-II, C-IV, D-I
- (2) A-IV, B-II, C-I, D-III
- (3) A-IV, B-II, C-III, D-I
- (4) A-II, B-IV, C-I, D-III

116

The protein portion of an enzyme is called :

- (1) Prosthetic group
- (2) Cofactor
- (3) Coenzyme
- (4) Apoenzyme

117 Which of the following enzyme(s) are NOT essential for gene cloning?

- A. Restriction enzymes
- B. DNA ligase
- C. DNA mutase
- D. DNA recombinase
- E. DNA polymerase

Choose the correct answer from the options given below :

- (1) B and C only
- (2) C and D only
- (3) A and B only
- (4) D and E only

118 Which of the following type of immunity is present at the time of birth and is a non-specific type of defence in the human body?

- (1) Humoral Immunity
- (2) Acquired Immunity
- (3) Innate Immunity
- (4) Cell-mediated Immunity

119 Which factor is important for termination of transcription?

- (1)  $\gamma$  (gamma)
- (2)  $\alpha$  (alpha)
- (3)  $\sigma$  (sigma)
- (4)  $\rho$  (rho)

120 Which of the following hormones released from the pituitary is actually synthesized in the hypothalamus?

- (1) Adenocorticotrophic hormone (ACTH)
- (2) Luteinizing hormone (LH)
- (3) Anti-diuretic hormone (ADH)
- (4) Follicle-stimulating hormone (FSH)

121 Which of the following microbes is NOT involved in the preparation of household products?

- A. *Aspergillus niger*
- B. *Lactobacillus*
- C. *Trichoderma polysporum*
- D. *Saccharomyces cerevisiae*
- E. *Propionibacterium sharmanii*

Choose the correct answer from the options given below:

- (1) C and E only
- (2) A and B only
- (3) A and C only
- (4) C and D only

122 Given below are two statements :

**Statement I :** Fig fruit is a non-vegetarian fruit as it has enclosed fig wasps in it.

**Statement II :** Fig wasp and fig tree exhibit mutual relationship as fig wasp completes its life cycle in fig fruit and fig fruit gets pollinated by fig wasp.

In the light of the above statements, choose the most appropriate answer from the options given below :

- (1) Statement I is incorrect but statement II is correct
- (2) Both statement I and statement II are correct
- (3) Both statement I and statement II are incorrect
- (4) Statement I is correct but statement II is incorrect

123 Role of the water vascular system in Echinoderms is :

- A. Respiration and Locomotion
- B. Excretion and Locomotion
- C. Capture and transport of food
- D. Digestion and Respiration
- E. Digestion and Excretion

Choose the correct answer from the options given below :

- (1) B, D and E Only
- (2) A and B Only
- (3) A and C Only
- (4) B and C Only

124 After maturation, in primary lymphoid organs, the lymphocytes migrate for interaction with antigens to secondary lymphoid organ(s) / tissue(s) like:

- A. thymus
- B. bone marrow
- C. spleen
- D. lymph nodes
- E. Peyer's patches

Choose the correct answer from the options given below:

- (1) C, D, E only
- (2) B, C, D only
- (3) A, B, C only
- (4) E, A, B only

125 Match List I with List II :

List I

List II

- A. The Evil Quartet I. Cryopreservation  
B. Ex situ conservation II. Alien species invasion  
C. *Lantana camara* III. Causes of biodiversity losses  
D. Dodo IV. Extinction
- Choose the option with all correct matches.
- (1) A-III, B-II, C-IV, D-I  
(2) A-III, B-II, C-I, D-IV  
(3) A-III, B-I, C-II, D-IV  
(4) A-III, B-IV, C-II, D-I

126 Read the following statements on plant growth and development.

- A. Parthenocarpy can be induced by auxins.  
B. Plant growth regulators can be involved in promotion as well as inhibition of growth.  
C. Dedifferentiation is a pre-requisite for re-differentiation.  
D. Abscisic acid is a plant growth promoter.  
E. Apical dominance promotes the growth of lateral buds.

Choose the option with all correct statements.

- (1) B, D, E only (2) A, B, C only  
(3) A, C, E only (4) A, D, E only

127 Match List I with List II.

List I

List II

- A. Pteridophyte I. *Salvia*  
B. Bryophyte II. *Ginkgo*  
C. Angiosperm III. *Polytrichum*  
D. Gymnosperm IV. *Salvinia*

Choose the option with all correct matches.

- (1) A-IV, B-III, C-II, D-I  
(2) A-III, B-IV, C-II, D-I  
(3) A-IV, B-III, C-I, D-II  
(4) A-III, B-IV, C-I, D-II

128

Why can't insulin be given orally to diabetic patients?

- (1) Its bioavailability will be increased  
(2) Human body will elicit strong immune response  
(3) It will be digested in Gastro-Intestinal (GI) tract  
(4) Because of structural variation

129

Which one of the following is the characteristic feature of gymnosperms?

- (1) Gymnosperms have flowers for reproduction.  
(2) Seeds are enclosed in fruits.  
(3) Seeds are naked.  
(4) Seeds are absent.

130

Frogs respire in water by skin and buccal cavity and on land by skin, buccal cavity and lungs.

Choose the correct answer from the following :

- (1) The statement is false for both the environment  
(2) The statement is true for water but false for land  
(3) The statement is true for both the environment  
(4) The statement is false for water but true for land

131

Silencing of specific mRNA is possible via RNAi because of -

- (1) Non-complementary ssRNA  
(2) Complementary dsRNA  
(3) Inhibitory ssRNA  
(4) Complementary tRNA

132

Twins are born to a family that lives next door to you. The twins are a boy and a girl. Which of the following must be true?

- (1) They have 75% identical genetic content.  
(2) They are monozygotic twins.  
(3) They are fraternal twins.  
(4) They were conceived through in vitro fertilization.

133 Match List I with List II :

List I	List II
A. Scutellum	I. Persistent nucellus
B. Non-albuminous seed	II. Cotyledon of Monocot seed
C. Epiblast	III. Groundnut
D. Perisperm	IV. Rudimentary cotyledon

Choose the option with all correct matches.

- (1) A-II, B-IV, C-III, D-I
- (2) A-II, B-III, C-IV, D-I
- (3) A-IV, B-III, C-II, D-I
- (4) A-IV, B-III, C-I, D-II

134 In frog, the Renal portal system is a special venous connection that acts to link :

- (1) Kidney and lower part of body
- (2) Liver and intestine
- (3) Liver and kidney
- (4) Kidney and intestine

135 Match List - I with List - II.

List - I	List - II
A. Heart	I. Erythropoietin
B. Kidney	II. Aldosterone
C. Gastro-intestinal tract	III. Atrial natriuretic factor
D. Adrenal Cortex	IV. Secretin

Choose the correct answer from the options given below :

- (1) A-III, B-I, C-IV, D-II
- (2) A-II, B-I, C-III, D-IV
- (3) A-IV, B-III, C-II, D-I
- (4) A-I, B-III, C-IV, D-II

136 Cardiac activities of the heart are regulated by :

- A. Nodal tissue
- B. A special neural centre in the medulla oblongata
- C. Adrenal medullary hormones
- D. Adrenal cortical hormones

Choose the correct answer from the options given below :

- (1) A, B and D Only
- (2) A, B and C Only
- (3) A, B, C and D
- (4) A, C and D Only

137 Streptokinase produced by *bacterium Sireptococcus* is used for

- (1) Removing clots from blood vessels
- (2) Curd production
- (3) Ethanol production
- (4) Liver disease treatment

138 Who is known as the father of Ecology in India?

- (1) Birbal Sahni
- (2) S. R. Kashyap
- (3) Ramdeo Misra
- (4) Ram Udar

[ Contd... ]

139 Given below are two statements : One is labelled as Assertion (A) and the other is labelled as Reason (R).

Assertion (A) : A typical unfertilised, angiosperm embryo sac at maturity is 8 nucleate and 7-celled.

Reason (R) : The egg apparatus has 2 polar nuclei.

In the light of the above statements, choose the correct answer from the options given below :

- (1) A is false but R is true  
(2) Both A and R are true and R is the correct explanation of A  
(3) Both A and R are true but R is NOT the correct explanation of A  
(4) A is true but R is false

140 Neoplastic characteristics of cells refer to :

- A. A mass of proliferating cell  
B. Rapid growth of cells  
C. Invasion and damage to the surrounding tissue  
D. Those confined to original location

Choose the correct answer from the options given below :

- (1) B, C, D only (2) A, B only  
(3) A, B, C only (4) A, B, D only

141

Given below are the stages in the life cycle of pteridophytes. Arrange the following stages in the correct sequence.

- A. Prothallus stage  
B. Meiosis in spore mother cells  
C. Fertilisation  
D. Formation of archegonia and antheridia in gametophyte.  
E. Transfer of antherozoids to the archegonia in presence of water.

Choose the correct answer from the options given below :

- (1) E, D, C, B, A  
(2) B, A, D, E, C  
(3) B, A, E, C, D  
(4) D, E, C, A, B

142 Given below are two statements : One is labelled as Assertion (A) and the other is labelled as Reason (R).

Assertion (A) : Both wind and water pollinated flowers are not very colourful and do not produce nectar.

Reason (R) : The flowers produce enormous amount of pollen grains in wind and water pollinated flowers.

In the light of the above statements, choose the correct answer from the options given below :

- (1) A is false but R is true  
(2) Both A and R are true and R is the correct explanation of A  
(3) Both A and R are true but R is NOT the correct explanation of A  
(4) A is true but R is false

143 Which one of the following enzymes contains 'Haem' as the prosthetic group?

- (1) Catalase  
(2) RuBisCo  
(3) Carbonic anhydrase  
(4) Succinate dehydrogenase

144 Match List - I with List - II.

List - I

List - II

A. Emphysema

I. Rapid spasms in muscle due to low  $Ca^{++}$  in body fluid

B. Angina Pectoris

II. Damaged alveolar walls and decreased respiratory surface

C. Glomerulonephritis

III. Acute chest pain when not enough oxygen is reaching to heart muscle

D. Tetany

IV. Inflammation of glomeruli of kidney

Choose the correct answer from the options given below :

- (1) A-II, B-III, C-IV, D-I  
(2) A-III, B-I, C-IV, D-II  
(3) A-III, B-I, C-II, D-IV  
(4) A-II, B-IV, C-III, D-I

145 Find the statement that is NOT correct with regard to the structure of monocot stem.

- (1) Phloem parenchyma is absent.
- (2) Hypodermis is parenchymatous.
- (3) Vascular bundles are scattered.
- (4) Vascular bundles are conjoint and closed.

146 Which of the following statement is correct about location of the male frog copulatory pad ?

- (1) First digit of the fore limb
- (2) First and Second digit of fore limb
- (3) First digit of hind limb
- (4) Second digit of fore limb

147 Given below are two statements :

**Statement I :** The primary source of energy in an ecosystem is solar energy.

**Statement II :** The rate of production of organic matter during photosynthesis in an ecosystem is called net primary productivity (NPP).

In the light of the above statements, choose the most appropriate answer from the options given below :

- (1) Statement I is incorrect but statement II is correct
- (2) Both statement I and statement II are correct
- (3) Both statement I and statement II are incorrect
- (4) Statement I is correct but statement II is incorrect

148 Identify the part of a bio-reactor which is used as a foam breaker from the given figure.

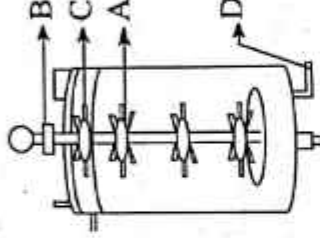

- (1) C
- (2) A
- (3) B
- (4) D

149 Polymerase chain reaction (PCR) amplifies DNA following the equation.

- (1)  $2N^2$
- (2)  $N^2$
- (3)  $2^n$
- (4)  $2n + 1$

150 Match List - I with List - II.

**List - I**

A. Head I. Enzymes

B. Middle piece II. Sperm motility

C. Acrosome III. Energy

D. Tail IV. Genetic material

Choose the correct answer from the options given below :

- (1) A-III, B-II, C-I, D-IV
- (2) A-IV, B-III, C-I, D-II
- (3) A-IV, B-III, C-II, D-I
- (4) A-III, B-IV, C-II, D-I

151

Given below are two statements :

**Statement I :** In a floral formula  $\oplus$  stands for zygomorphic nature of the flower, and  $\underline{G}$  stands for inferior ovary.

**Statement II :** In a floral formula  $\oplus$  stands for actinomorphic nature of the flower and  $\underline{G}$  stands for superior ovary.

In the light of the above statements, choose the correct answer from the options given below :

- (1) Statement I is incorrect but Statement II is correct
- (2) Both Statement I and Statement II are correct
- (3) Both Statement I and Statement II are incorrect
- (4) Statement I is correct but Statement II is incorrect

152 From the statements given below choose the correct option :

- A. The eukaryotic ribosomes are 80S and prokaryotic ribosomes are 70S.
- B. Each ribosome has two sub-units.
- C. The two sub-units of 80S ribosome are 60S and 40S while that of 70S are 50S and 30S.
- D. The two sub-units of 80S ribosome are 60S and 20S and that of 70S are 50S and 20S.
- E. The two sub-units of 80S are 60S and 30S and that of 70S are 50S and 30S.

- (1) B, D, E are true
- (2) A, B, C are true
- (3) A, B, D are true
- (4) A, B, E are true

153

Each of the following characteristics represent a Kingdom proposed by Whittaker. Arrange the following in increasing order of complexity of body organization.

- A. Multicellular heterotrophs with cell wall made of chitin.
- B. Heterotrophs with tissue/organ/organ system level of body organization.
- C. Prokaryotes with cell wall made of polysaccharides and amino acids.
- D. Eukaryotic autotrophs with tissue/organ level of body organization.
- E. Eukaryotes with cellular body organization.

Choose the correct answer from the options given below :

- (1) C, E, A, B, D
- (2) A, C, E, B, D
- (3) C, E, A, D, B
- (4) A, C, E, D, B

154

The correct sequence of events in the life cycle of bryophytes is

- A. Fusion of antherozoid with egg.
- B. Attachment of gametophyte to substratum.
- C. Reduction division to produce haploid spores.
- D. Formation of sporophyte.
- E. Release of antherozoids into water.

Choose the correct answer from the options given below :

- (1) D, E, A, B, C
- (2) D, E, A, C, B
- (3) B, E, A, C, D
- (4) B, E, A, D, C

155 Which are correct:

- A. Computed tomography and magnetic resonance imaging detect cancers of internal organs.
- B. Chemotherapeutic drugs are used to kill non-cancerous cells.
- C.  $\alpha$ -interferon activate the cancer patients' immune system and helps in destroying the tumour.
- D. Chemotherapeutic drugs are biological response modifiers.
- E. In the case of leukaemia blood cell counts are decreased.

Choose the correct answer from the options given below:

- (1) A and C only
- (2) B and D only
- (3) D and E only
- (4) C and D only

156 Name the class of enzyme that usually catalyze the following reaction :

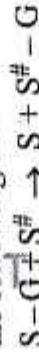

Where, G  $\rightarrow$  a group other than hydrogen

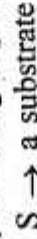

- (1) Ligase
- (2) Hydrolase
- (3) Lyase
- (4) Transferase

157. Find the correct statements :

- A. In human pregnancy, the major organ systems are formed at the end of 12 weeks.
- B. In human pregnancy the major organ systems are formed at the end of 8 weeks.
- C. In human pregnancy heart is formed after one month of gestation.
- D. In human pregnancy, limbs and digits develop by the end of second month.
- E. In human pregnancy the appearance of hair is usually observed in the fifth month.

Choose the correct answer from the options given below :

- (1) A, C, D and E Only
- (2) A and E Only
- (3) B and C Only
- (4) B, C, D and E Only

158 Which of the following is an example of non-distilled alcoholic beverage produced by yeast?

- (1) Rum
- (2) Whisky
- (3) Brandy
- (4) Beer

159 Given below are two statements :

**Statement I :** In the RNA world, RNA is considered the first genetic material evolved to carry out essential life processes. RNA acts as a genetic material and also as a catalyst for some important biochemical reactions in living systems. Being reactive, RNA is unstable.

**Statement II :** DNA evolved from RNA and is a more stable genetic material. Its double helical strands being complementary, resist changes by evolving repairing mechanism. In the light of the above statements, choose the most appropriate answer from the options given below :

- (1) Statement I is incorrect but statement II is correct
- (2) Both statement I and statement II are correct
- (3) Both statement I and statement II are incorrect
- (4) Statement I is correct but statement II is incorrect

160

Given below are two statements :

**Statement I :** Transfer RNAs and ribosomal RNA do not interact with mRNA.

**Statement II :** RNA interference (RNAi) takes place in all eukaryotic organisms as a method of cellular defence.

In the light of the above statements, choose the most appropriate answer from the options given below :

- (1) Statement I is incorrect but Statement II is correct
- (2) Both Statement I and Statement II are correct
- (3) Both Statement I and Statement II are incorrect
- (4) Statement I is correct but Statement II is incorrect

[ Contd... ]

161 Which of the following diagrams is correct with regard to the proximal (P) and distal (D) tubule of the Nephron.

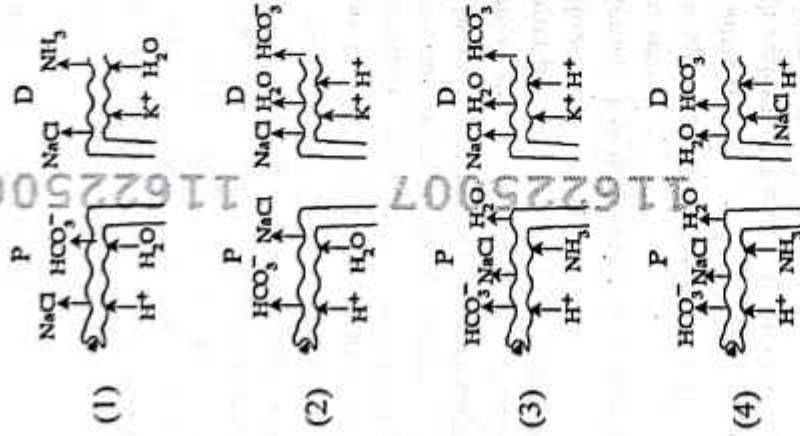

162 What is the pattern of inheritance for polygenic trait?

- (1) X-linked recessive inheritance pattern
- (2) Mendelian inheritance pattern
- (3) Non-mendelian inheritance pattern
- (4) Autosomal dominant pattern

163 In the seeds of cereals, the outer covering of endosperm separates the embryo by a protein-rich layer called:

- (1) Aleurone layer
- (2) Coleoptile
- (3) Coleorhiza
- (4) Integument

164 Match List I with List II :

List I	List II
A. Chlorophyll a	I. Yellow-green
B. Chlorophyll b	II. Yellow
C. Xanthophylls	III. Blue-green
D. Carotenoids	IV. Yellow to Yellow-orange

Choose the option with all correct matches.

- (1) A-I, B-IV, C-III, D-II
- (2) A-III, B-IV, C-II, D-I
- (3) A-III, B-I, C-II, D-IV
- (4) A-I, B-II, C-IV, D-III

165 Which of the following genetically engineered organisms was used by Eli Lilly to prepare human insulin?

- (1) Phage
- (2) Yeast
- (3) Bacterium
- (4) Virus

166 Which of the following are the post-transcriptional events in an eukaryotic cell?

- A. Transport of pre-mRNA to cytoplasm prior to splicing.
  - B. Removal of introns and joining of exons.
  - C. Addition of methyl group at 5' end of hnRNA.
  - D. Addition of adenine residues at 3' end of hnRNA.
  - E. Base pairing of two complementary RNAs.
- Choose the correct answer from the options given below :
- (1) C, D, E only
  - (2) A, B, C only
  - (3) B, C, D only
  - (4) B, C, E only

167 Match List - I with List - II.

List - I

- A. Centromere
  - B. Cilium
  - C. Cristae
  - D. Cell membrane
- List - II
- I. Mitochondrion
  - II. Cell division
  - III. Cell movement
  - IV. Phospholipid Bilayer

Choose the correct answer from the options given below :

- (1) A-II, B-III, C-I, D-IV
- (2) A-I, B-II, C-III, D-IV
- (3) A-II, B-I, C-IV, D-III
- (4) A-IV, B-II, C-III, D-I

168 Match List I with List II :

List-I

- A. Alfred Hershey and Martha Chase

List-II

- I. Streptococcus pneumoniae
- II. Densely packed and dark-stained
- III. Loosely packed and light-stained
- IV. DNA as genetic material

Choose the correct answer from the options given below :

- (1) A-III, B-II, C-IV, D-I
- (2) A-II, B-IV, C-I, D-III
- (3) A-IV, B-II, C-I, D-III
- (4) A-IV, B-III, C-I, D-II

169 Which chromosome in the human genome has the highest number of genes?

- (1) Chromosome 10
- (2) Chromosome X
- (3) Chromosome Y
- (4) Chromosome 1

170 What are the potential drawbacks in adoption of the IVF method?

- A. High fatality risk to mother
- B. Expensive instruments and reagents
- C. Husband/wife necessary for being donors
- D. Less adoption of orphans
- E. Not available in India
- F. Possibility that the early embryo does not survive

Choose the correct answer from the options given below :

- (1) A, B, C, E, F only
- (2) B, D, F only
- (3) A, C, D, F only
- (4) A, B, C, D only

171 Which one of the following is an example of ex-situ conservation?

- (1) Protected areas
- (2) National Park
- (3) Wildlife Sanctuary
- (4) Zoos and botanical gardens

172 A specialised membranous structure in a prokaryotic cell which helps in cell wall formation, DNA replication and respiration is :

- (1) Endoplasmic Reticulum
- (2) Mesosome
- (3) Chromatophores
- (4) Cristae

173

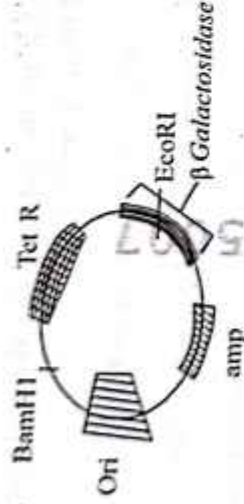

In the above represented plasmid an alien piece of DNA is inserted at EcoRI site. Which of the following strategies will be chosen to select the recombinant colonies?

- (1) Blue color colonies grown on ampicillin plates can be selected.
- (2) Using ampicillin & tetracyclin containing medium plate.
- (3) Blue color colonies will be selected.
- (4) White color colonies will be selected.

174

What is the name of the blood vessel that carries deoxygenated blood from the body to the heart in a frog?

- (1)  Vena cava
- (2) Aorta
- (3) Pulmonary artery
- (4) Pulmonary vein

175 Which of following organisms *cannot* fix nitrogen?

- A. *Azotobacter*
- B. *Oscillatoria*
- C. *Anabaena*
- D. *Volvox*
- E. *Nostoc*

Choose the *correct* answer from the options given below:

- (1) E only
- (2) A only
- (3) D only
- (4)  B only

47\_English ]

30

176

While trying to find out the characteristic of a newly found animal, a researcher did the histology of adult animal and observed a cavity with presence of mesodermal tissue towards the body wall but no mesodermal tissue was observed towards the alimentary canal. What could be the possible coelome of that animal?

- (1) Spongocoelomate
- (2) Acoelomate
- (3) Pseudocoelomate
- (4) Schizocoelomate

177

Which one of the following statements refers to Reductionist Biology?

- (1) Behavioural approach to study and understand living organisms.
- (2) Physico-chemical approach to study and understand living organisms.
- (3) Physiological approach to study and understand living organisms.
- (4) Chemical approach to study and understand living organisms.

178

Epiphytes that are growing on a mango branch is an example of which of the following?

- (1)  Amensalism
- (2)  Commensalism
- (3) Mutualism
- (4) Predation

179

Which one of the following phytohormones promotes nutrient mobilization which helps in the delay of leaf senescence in plants?

- (1) Cytokinin
- (2)  Ethylene
- (3) Abscisic acid
- (4) Gibberellin

180

The complex II of mitochondrial electron transport chain is also known as

- (1)  NADH dehydrogenase
- (2) Cytochrome bc<sub>1</sub>
- (3) Succinate dehydrogenase
- (4) Cytochrome c oxidase

[ Contd...

115797484

NARMADA

Test Booklet Code

48

ENGLISH

Test Booklet No.

Do not open this Test Booklet until you are asked to do so.

This Booklet contains 32 pages, including Rough Page.

Important Instructions:

1. The Answer Sheet is inside this Test Booklet. When you are directed to open the Test Booklet, take out the Answer Sheet and fill in the particulars on ORIGINAL Copy carefully with blue/black ball point pen only.
2. The test is of 3 hours duration and the Test Booklet contains 180 multiple-choice questions (four options with a single correct answer) from Physics, Chemistry and Biology (Botany and Zoology).
3. Wherever the symbols/constants are not mentioned, they are to be considered as per their standard meaning/value.
4. Each question carries 4 marks. For each correct response, the candidate will get 4 marks. For each incorrect response, one mark will be deducted from the total scores. The maximum marks are 720.
5. Use Blue/Black Ball Point Pen only for writing particulars on this page/marking responses on Answer Sheet.
6. Rough work is to be done in the space provided for this purpose in the Test Booklet only.
7. On completion of the test, the candidate must hand over the Answer Sheet (ORIGINAL and OFFICE Copy) to the Invigilator before leaving the Room/Hall. The candidates are allowed to take away this Test Booklet with them.
8. The CODE for this Booklet is "48". Make sure to enter this code in the OMR answer sheet.

9. The candidates should ensure that the Answer Sheet is not folded. Do not make any stray marks on the Answer Sheet. Do not write your Roll No. anywhere else except in the specified space in the Test Booklet/ Answer Sheet.
10. Use of white fluid for correction is NOT permissible on the Answer Sheet.
11. Each candidate must show on-demand his/her Admit Card to the Invigilator.
12. No candidate, without special permission of the centre Superintendent or Invigilator, would leave his/her seat.
13. The candidates should not leave the Examination Hall without handing over their Answer Sheet to the Invigilator on duty and sign (with time) the Attendance Sheet twice. Cases, where a candidate has not signed the Attendance Sheet second time, will be deemed not to have handed over the Answer Sheet and dealt with as an Unfair Means case.
14. Use of Electronic/Manual Calculator is prohibited.
15. The candidates are governed by all Rules and Regulations of the examination with regard to their conduct in the Examination Room/Hall. All cases of unfair means will be dealt with as per the Rules and Regulations of this examination along with Public Examinations (Prevention of unfair means act 2024).
16. No part of the Test Booklet and Answer Sheet shall be detached under any circumstances.
17. The candidates will write the Correct Test Booklet Code as given in the Test Booklet/Answer Sheet in the Attendance Sheet.
18. If a candidate marks more than one answers for a question in the OMR Sheet, it will be treated as incorrect and negative marking will be applicable.



Name of the Candidate (in Capitals): ARYAN RANA

Roll Number : in figures 440 410 60 60

: in words four hundred forty one lakh six thousand

Centre of Examination (in Capitals): Sambhodaya

Candidate's Signature : Aryan Rana Invigilator's Signature : .....

Facsimile signature stamp of Centre Superintendent : .....

1 A parallel plate capacitor made of circular plates is being charged such that the surface charge density on its plates is increasing at a constant rate with time. The magnetic field arising due to displacement current is :

- (1) non-zero everywhere with maximum at the imaginary cylindrical surface connecting peripheries of the plates
- (2) zero between the plates and non-zero outside
- (3) zero at all places
- (4) constant between the plates and zero outside the plates

2 An electric dipole with dipole moment  $5 \times 10^{-6} \text{ Cm}$  is aligned with the direction of a uniform electric field of magnitude  $4 \times 10^5 \text{ N/C}$ . The dipole is then rotated through an angle of  $60^\circ$  with respect to the electric field. The change in the potential energy of the dipole is :

- (1) 1.2 J
- (2) 1.5 J
- (3) 0.8 J
- (4) 1.0 J

3 A ball of mass 0.5 kg is dropped from a height of 40 m. The ball hits the ground and rises to a height of 10 m. The impulse imparted to the ball during its collision with the ground is (Take  $g = 9.8 \text{ m/s}^2$ )

- (1) 0
- (2) 84 NS
- (3) 21 NS
- (4) 7 NS

4 The intensity of transmitted light when a polaroid sheet, placed between two crossed polaroids at  $22.5^\circ$  from the polarization axis of one of the polaroid, is ( $I_0$  is the intensity of polarised light after passing through the first polaroid):

- (1)  $\frac{I_0}{8}$
- (2)  $\frac{I_0}{16}$
- (3)  $\frac{I_0}{2}$
- (4)  $\frac{I_0}{4}$

5 The kinetic energies of two similar cars A and B are 100 J and 225 J respectively. On applying breaks, car A stops after 1000 m and car B stops after 1500 m. If  $F_A$  and  $F_B$  are the forces applied by the breaks on cars A and B, respectively, then the ratio  $F_A/F_B$  is

- (1)  $\frac{1}{3}$
- (2)  $\frac{1}{2}$
- (3)  $\frac{3}{2}$
- (4)  $\frac{2}{3}$

6 The current passing through the battery in the given circuit, is:

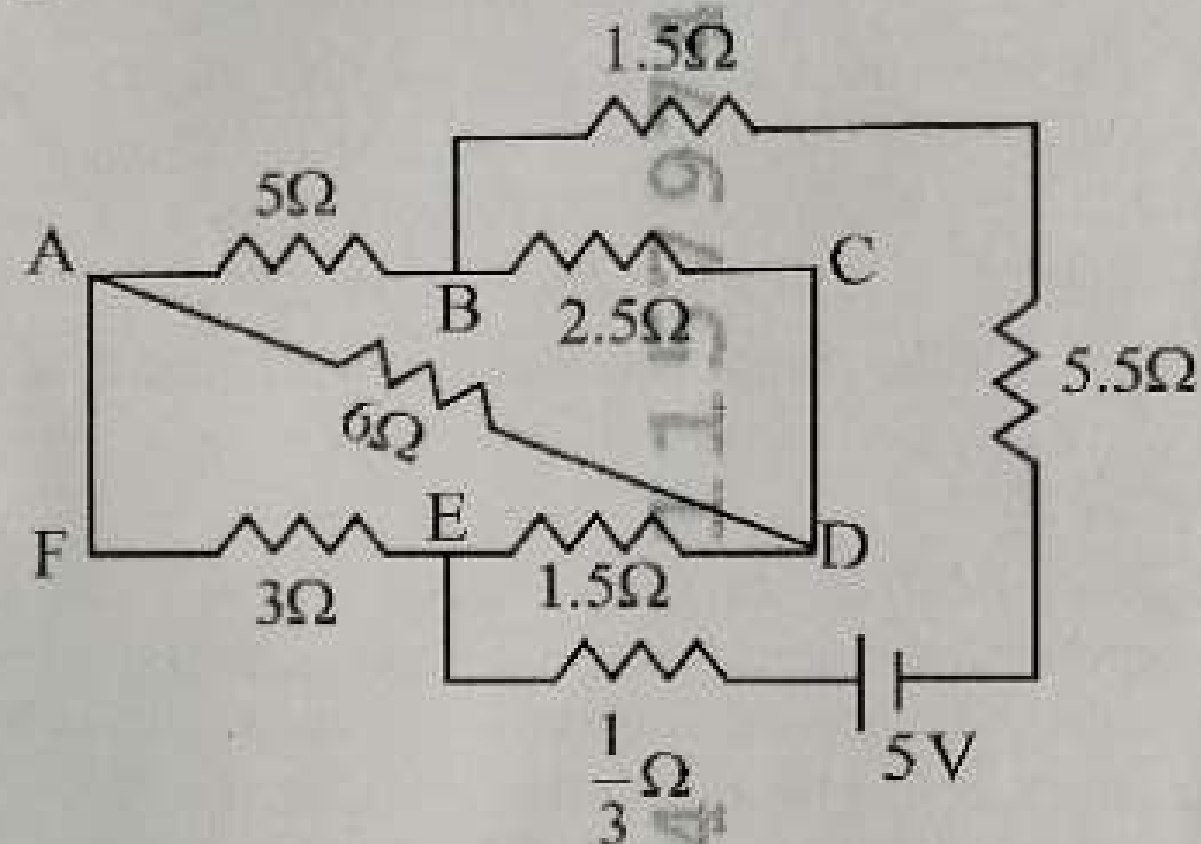

- (1) 2.5 A
- (2) 1.5 A
- (3) 2.0 A
- (4) 0.5 A

7 Three identical heat conducting rods are connected in series as shown in the figure. The rods on the sides have thermal conductivity  $2K$  while that in the middle has thermal conductivity  $K$ . The left end of the combination is maintained at temperature  $3T$  and the right end at  $T$ . The rods are thermally insulated from outside. In steady state, temperature at the left junction is  $T_1$  and that at the right junction is  $T_2$ . The ratio  $T_1/T_2$  is

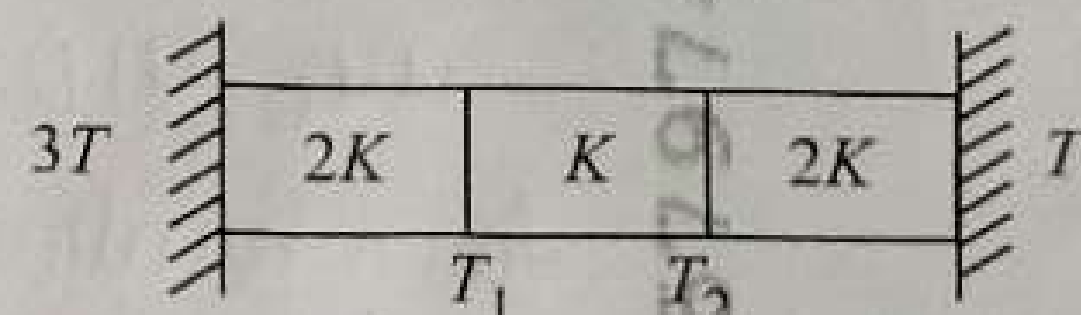

- (1)  $\frac{5}{3}$
- (2)  $\frac{5}{4}$
- (3)  $\frac{3}{2}$
- (4)  $\frac{4}{3}$

- 8 In an oscillating spring mass system, a spring is connected to a box filled with sand. As the box oscillates, sand leaks slowly out of the box vertically so that the average frequency  $\omega(t)$  and average amplitude  $A(t)$  of the system change with time  $t$ . Which one of the following options schematically depicts these changes correctly?

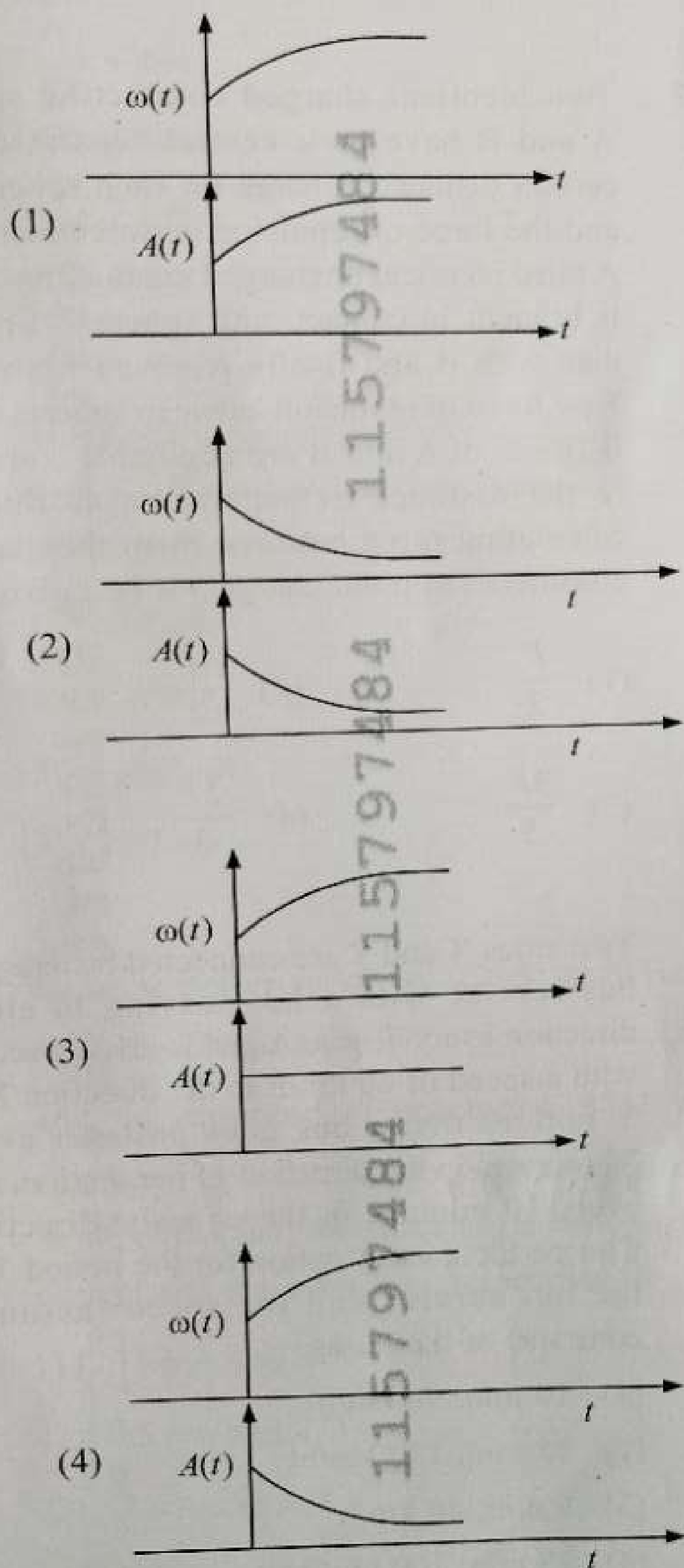

- 9 AB is a part of an electrical circuit (see figure). The potential difference " $V_A - V_B$ ", at the instant when current  $i = 2$  A and is increasing at a rate of 1 amp / second is:

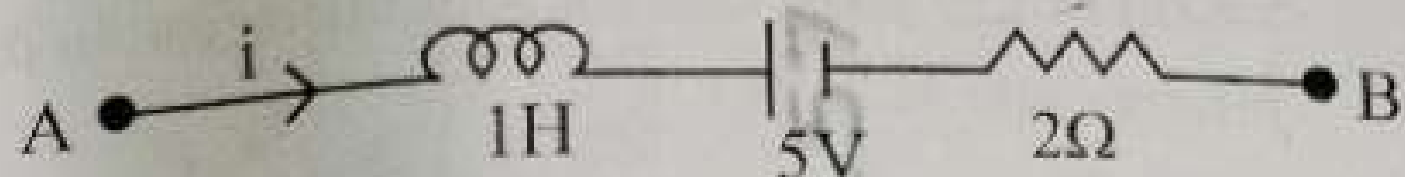

- (1) 9 volt                      (2) 10 volt  
(3) 5 volt                      (4) 6 volt
- 10 A particle of mass  $m$  is moving around the origin with a constant force  $F$  pulling it towards the origin. If Bohr model is used to describe its motion, the radius  $r$  of the  $n^{\text{th}}$  orbit and the particle's speed  $v$  in the orbit depend on  $n$  as
- (1)  $r \propto n^{2/3}$ ;  $v \propto n^{1/3}$   
(2)  $r \propto n^{4/3}$ ;  $v \propto n^{-1/3}$   
(3)  $r \propto n^{1/3}$ ;  $v \propto n^{1/3}$   
(4)  $r \propto n^{1/3}$ ;  $v \propto n^{2/3}$
- 11 In some appropriate units, time ( $t$ ) and position ( $x$ ) relation of a moving particle is given by  $t = x^2 + x$ . The acceleration of the particle is
- (1)  $+\frac{2}{(x+1)^3}$               (2)  $+\frac{2}{2x+1}$   
(3)  $-\frac{2}{(x+2)^3}$               (4)  $-\frac{2}{(2x+1)^3}$
- 12 A model for quantized motion of an electron in a uniform magnetic field  $B$  states that the flux passing through the orbit of the electron is  $n(h/e)$  where  $n$  is an integer,  $h$  is Planck's constant and  $e$  is the magnitude of electron's charge. According to the model, the magnetic moment of an electron in its lowest energy state will be ( $m$  is the mass of the electron)
- (1)  $\frac{heB}{\pi m}$                       (2)  $\frac{heB}{2\pi m}$   
(3)  $\frac{he}{\pi m}$                       (4)  $\frac{he}{2\pi m}$

13 A microscope has an objective of focal length 2 cm, eyepiece of focal length 4 cm and the tube length of 40 cm. If the distance of distinct vision of eye is 25 cm, the magnification in the microscope is

- (1) 150                      (2) 250  
(3) 100                      (4) 125

14 There are two inclined surfaces of equal length ( $L$ ) and same angle of inclination  $45^\circ$  with the horizontal. One of them is rough and the other is perfectly smooth. A given body takes 2 times as much time to slide down on rough surface than on the smooth surface. The coefficient of kinetic friction ( $\mu_k$ ) between the object and the rough surface is close to

- (1) 0.5                      (2) 0.75  
(3) 0.25                      (4) 0.40

15 A full wave rectifier circuit with diodes ( $D_1$ ) and ( $D_2$ ) is shown in the figure. If input supply voltage  $V_{in} = 220\sin(100\pi t)$  volt, then at  $t = 15 \text{ msec}$

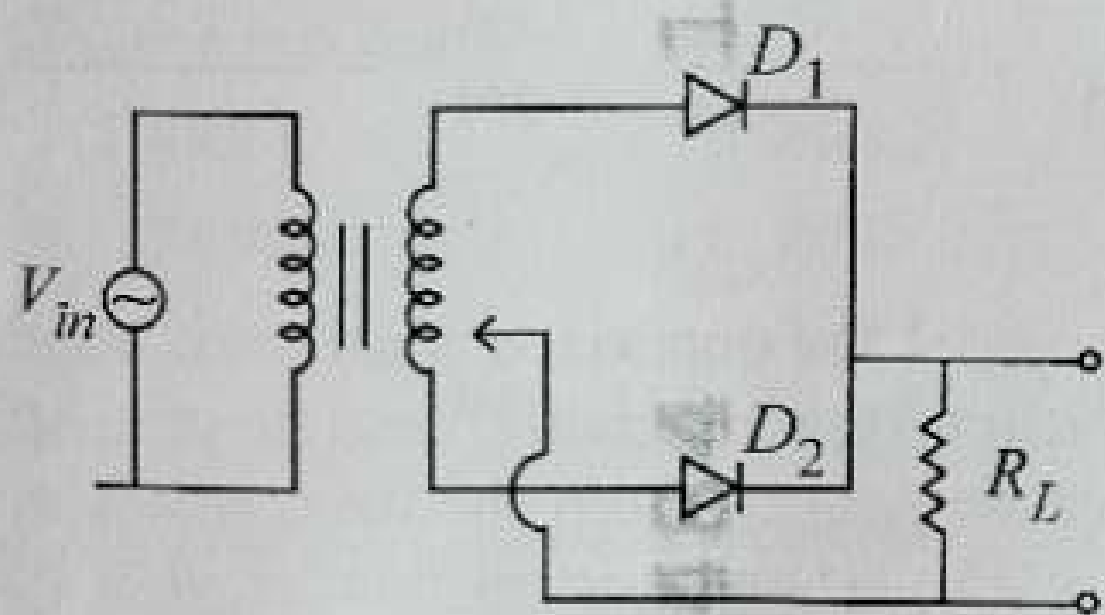

- (1)  $D_1$  and  $D_2$  both are forward biased  
(2)  $D_1$  and  $D_2$  both are reverse biased  
(3)  $D_1$  is forward biased,  $D_2$  is reverse biased  
(4)  $D_1$  is reverse biased,  $D_2$  is forward biased

16 A uniform rod of mass 20 kg and length 5 m leans against a smooth vertical wall making an angle of  $60^\circ$  with it. The other end rests on a rough horizontal floor. The friction force that the floor exerts on the rod is (take  $g = 10 \text{ m/s}^2$ )

- (1) 200 N                      (2)  $200\sqrt{3}$  N  
(3) 100 N                      (4)  $100\sqrt{3}$  N

17 Two identical charged conducting spheres A and B have their centres separated by a certain distance. Charge on each sphere is  $q$  and the force of repulsion between them is  $F$ . A third identical uncharged conducting sphere is brought in contact with sphere A first and then with B and finally removed from both. New force of repulsion between spheres A and B (Radii of A and B are negligible compared to the distance of separation so that for calculating force between them they can be considered as point charges) is best given as :

- (1)  $\frac{F}{2}$                       (2)  $\frac{3F}{8}$   
(3)  $\frac{3F}{5}$                       (4)  $\frac{2F}{3}$

18 Two cities X and Y are connected by a regular bus service with a bus leaving in either direction every  $T$  min. A girl is driving scooter with a speed of 60 km/h in the direction X to Y notices that a bus goes past her every 30 minutes in the direction of her motion, and every 10 minutes in the opposite direction. Choose the correct option for the period  $T$  of the bus service and the speed (assumed constant) of the buses.

- (1) 10 min, 90 km/h  
(2) 15 min, 120 km/h  
(3) 9 min, 40 km/h  
(4) 25 min, 100 km/h

19 A container has two chambers of volumes  $V_1 = 2$  litres and  $V_2 = 3$  litres separated by a partition made of a thermal insulator. The chambers contains  $n_1 = 5$  and  $n_2 = 4$  moles of ideal gas at pressures  $p_1 = 1$  atm and  $p_2 = 2$  atm, respectively. When the partition is removed, the mixture attains an equilibrium pressure of :

- (1) 1.4 atm
- (2) 1.8 atm
- (3) 1.3 atm
- (4) 1.6 atm

20 De-Broglie wavelength of an electron orbiting in the  $n = 2$  state of hydrogen atom is close to (Given Bohr radius =  $0.052 \text{ nm}$ )

- (1)  $1.67 \text{ nm}$
- (2)  $2.67 \text{ nm}$
- (3)  $0.067 \text{ nm}$
- (4)  $0.67 \text{ nm}$

21 To an ac power supply of  $220 \text{ V}$  at  $50 \text{ Hz}$ , a resistor of  $20 \Omega$ , a capacitor of reactance  $25 \Omega$  and an inductor of reactance  $45 \Omega$  are connected in series. The corresponding current in the circuit and the phase angle between the current and the voltage is, respectively -

- (1)  $15.6 \text{ A}$  and  $30^\circ$
- (2)  $15.6 \text{ A}$  and  $45^\circ$
- (3)  $7.8 \text{ A}$  and  $30^\circ$
- (4)  $7.8 \text{ A}$  and  $45^\circ$

48\_English ]

22 Which of the following options represent the variation of photoelectric current with property of light shown on the x-axis?

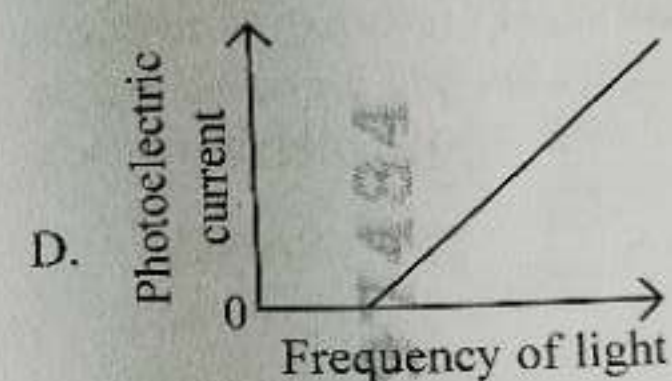
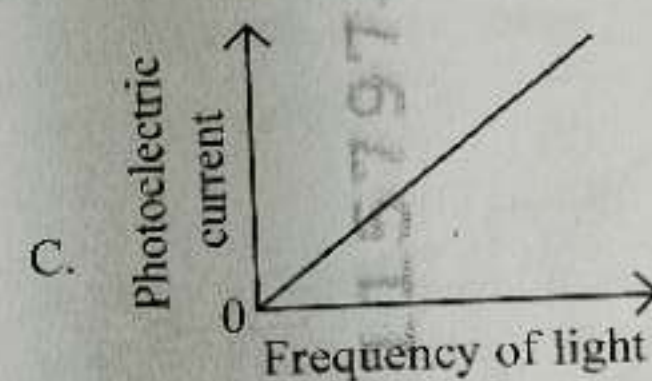
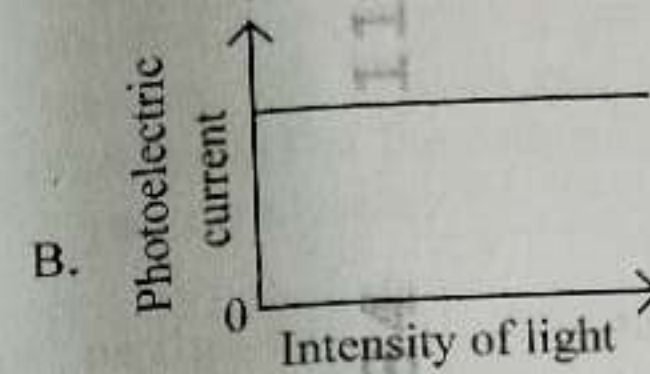
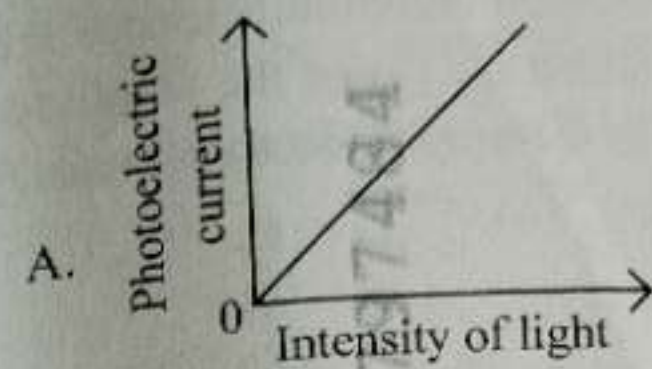

- (1) A and D
- (2) B and D
- (3) A only
- (4) A and C

23 A pipe open at both ends has a fundamental frequency  $f$  in air. The pipe is now dipped vertically in a water drum to half of its length. The fundamental frequency of the air column is now equal to :

- (1)  $\frac{3f}{2}$
- (2)  $2f$
- (3)  $\frac{f}{2}$
- (4)  $f$

- 36 A sphere of radius  $R$  is cut from a larger solid sphere of radius  $2R$  as shown in the figure. The ratio of the moment of inertia of the smaller sphere to that of the rest part of the sphere about the Y-axis is :

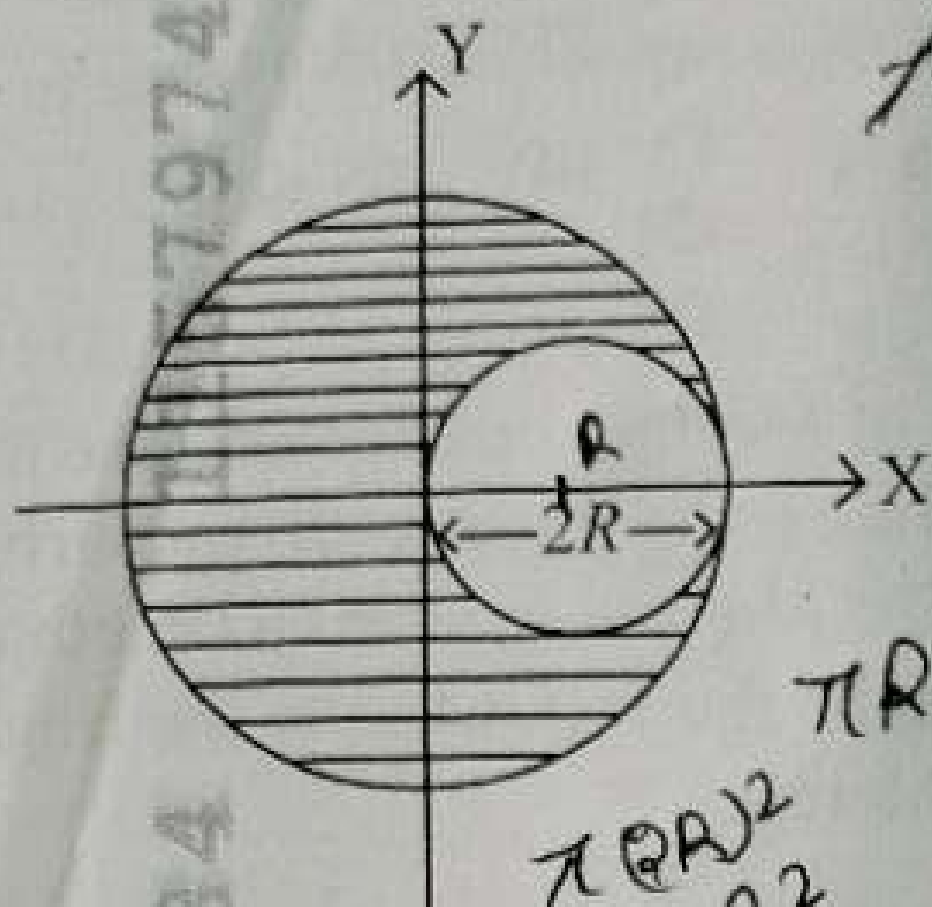

- (1)  $\frac{7}{57}$  (2)  $\frac{7}{64}$   
 (3)  $\frac{7}{8}$  (4)  $\frac{7}{40}$

- 37 An electron (mass  $9 \times 10^{-31}$  kg and charge  $1.6 \times 10^{-19}$  C) moving with speed  $c/100$  ( $c =$  speed of light) is injected into a magnetic field  $B$  of magnitude  $9 \times 10^{-4}$  T perpendicular to its direction of motion. We wish to apply a uniform electric field  $\vec{E}$  together with the magnetic field so that the electron does not deflect from its path. Then (speed of light  $c = 3 \times 10^8$  ms $^{-1}$ )

- (1)  $\vec{E}$  is parallel to  $\vec{B}$  and its magnitude is  $27 \times 10^2$  V m $^{-1}$   
 (2)  $\vec{E}$  is parallel to  $\vec{B}$  and its magnitude is  $27 \times 10^4$  V m $^{-1}$   
 (3)  $\vec{E}$  is perpendicular to  $\vec{B}$  and its magnitude is  $27 \times 10^4$  V m $^{-1}$   
 (4)  $\vec{E}$  is perpendicular to  $\vec{B}$  and its magnitude is  $27 \times 10^2$  V m $^{-1}$

- 38 The electric field in a plane electromagnetic wave is given by

$$E_z = 60 \cos(5x + 1.5 \times 10^9 t) \text{ V/m.}$$

Then expression for the corresponding magnetic field is (here subscripts denote the direction of the field) :

- (1)  $B_z = 60 \cos(5x + 1.5 \times 10^9 t) \text{ T}$   
 (2)  $B_y = 60 \sin(5x + 1.5 \times 10^9 t) \text{ T}$   
 (3)  $B_y = 2 \times 10^{-7} \cos(5x + 1.5 \times 10^9 t) \text{ T}$   
 (4)  $B_x = 2 \times 10^{-7} \cos(5x + 1.5 \times 10^9 t) \text{ T}$

- 39 A body weighs 48 N on the surface of the earth. The gravitational force experienced by the body due to the earth at a height equal to one-third the radius of the earth from its surface is :

- (1) 32 N  
 (2) 36 N  
 (3) 16 N  
 (4) 27 N

- 40 An unpolarized light beam travelling in air is incident on a medium of refractive index 1.73 at Brewster's angle. Then-

- (1) both reflected and transmitted light are perfectly polarized with angles of reflection and refraction close to  $60^\circ$  and  $30^\circ$ , respectively.  
 (2) transmitted light is completely polarized with angle of refraction close to  $30^\circ$   
 (3) reflected light is completely polarized and the angle of reflection is close to  $60^\circ$   
 (4) reflected light is partially polarized and the angle of reflection is close to  $30^\circ$

- 41 A constant voltage of 50 V is maintained between the points A and B of the circuit shown in the figure. The current through the branch CD of the circuit is :

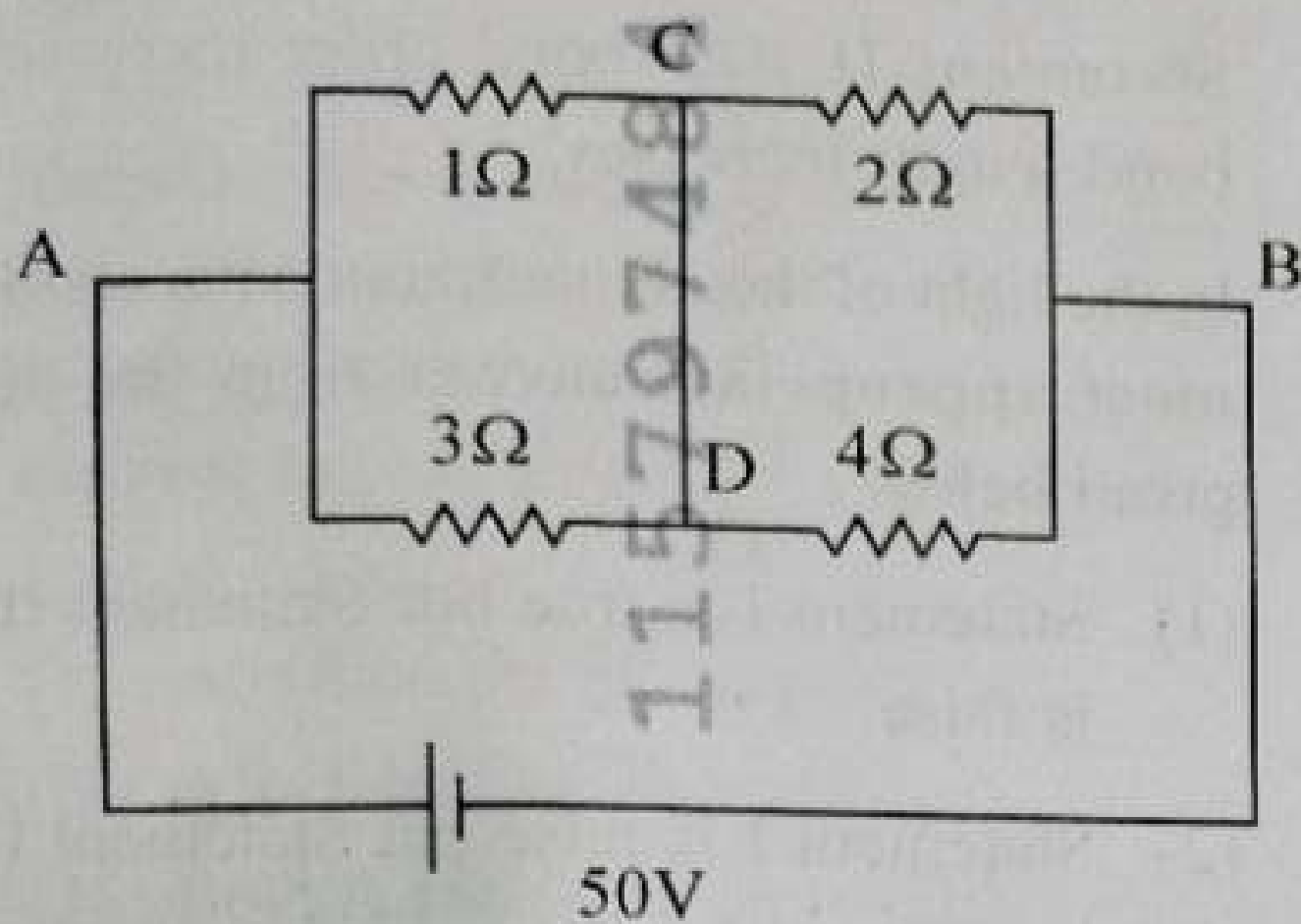

- (1) 2.5 A                      (2) 3.0 A  
(3) 1.5 A                      (4) 2.0 A

- 42 The plates of a parallel plate capacitor are separated by  $d$ . Two slabs of different dielectric constant  $K_1$  and  $K_2$  with thickness  $\frac{3}{8}d$  and  $\frac{d}{2}$ , respectively are inserted in the capacitor. Due to this, the capacitance becomes two times larger than when there is nothing between the plates.

If  $K_1 = 1.25 K_2$ , the value of  $K_1$  is :

- (1) 1.60                      (2) 1.33  
(3) 2.66                      (4) 2.33

- 43 Consider the diameter of a spherical object being measured with the help of a Vernier callipers. Suppose its 10 Vernier Scale Divisions (V.S.D.) are equal to its 9 Main Scale Divisions (M.S.D.). The least division in the M.S. is 0.1 cm and the zero of V.S. is at  $x = 0.1$  cm when the jaws of Vernier callipers are closed.

If the main scale reading for the diameter is  $M = 5$  cm and the number of coinciding vernier division is 8, the measured diameter after zero error correction, is

- (1) 4.98 cm                      (2) 5.00 cm  
(3) 5.18 cm                      (4) 5.08 cm

- 44 A 2 amp current is flowing through two different small circular copper coils having radii ratio 1:2. The ratio of their respective magnetic moments will be

- (1) 2:1  
(2) 4:1  
(3) 1:4  
(4) 1:2

- 45 Consider a water tank shown in the figure. It has one wall at  $x = L$  and can be taken to be very wide in the  $z$  direction. When filled with a liquid of surface tension  $S$  and density  $\rho$ , the liquid surface makes angle  $\theta_0$  ( $\theta_0 \ll 1$ ) with the  $x$ -axis at  $x = L$ . If  $y(x)$  is the height of the surface then the equation for  $y(x)$  is :

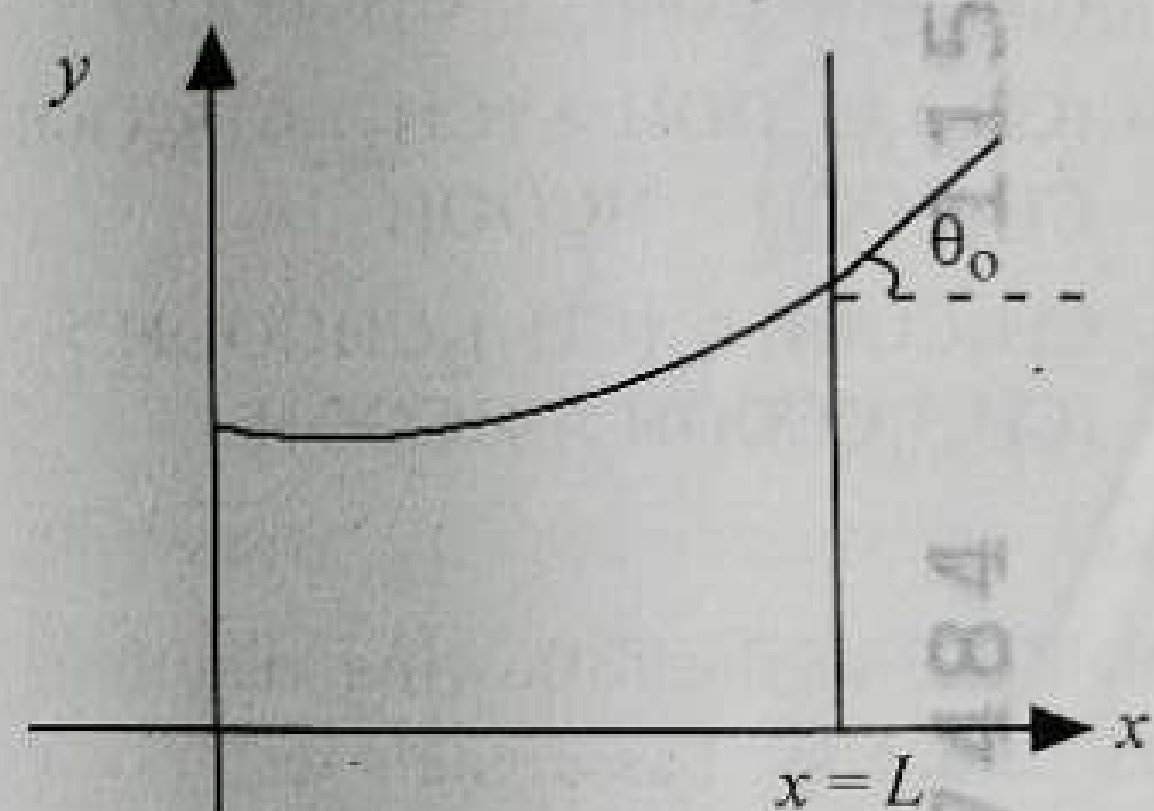

(take  $\theta(x) = \sin \theta(x) = \tan \theta(x) = \frac{dy}{dx}$ ,  $g$  is the acceleration due to gravity)

- (1)  $\frac{d^2 y}{dx^2} = \sqrt{\frac{\rho g}{S}}$   
(2)  $\frac{dy}{dx} = \sqrt{\frac{\rho g}{S}} x$   
(3)  $\frac{d^2 y}{dx^2} = \frac{\rho g}{S} x$   
(4)  $\frac{d^2 y}{dx^2} = \frac{\rho g}{S} y$

- 46 Identify the suitable reagent for the following conversion.

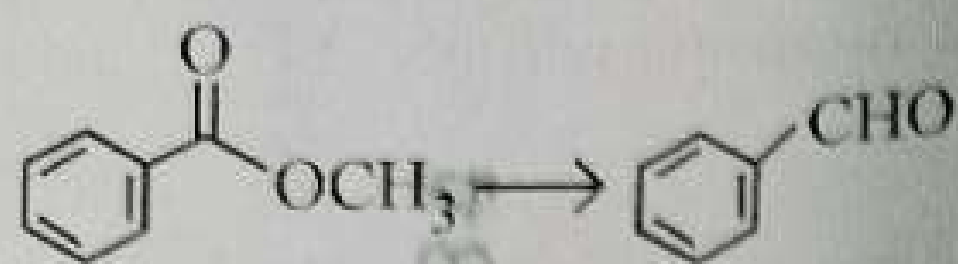

- (1) (i)  $\text{NaBH}_4$ , (ii)  $\text{H}^+/\text{H}_2\text{O}$   
 (2)  $\text{H}_2 / \text{Pd-BaSO}_4$   
 (3) (i)  $\text{LiAlH}_4$ , (ii)  $\text{H}^+/\text{H}_2\text{O}$   
 (4) (i)  $\text{AlH}(\text{iBu})_2$  (ii)  $\text{H}_2\text{O}$
- 47 The correct order of decreasing acidity of the following aliphatic acids is :

- (1)  $\text{HCOOH} > \text{CH}_3\text{COOH} > (\text{CH}_3)_2\text{CHCOOH} > (\text{CH}_3)_3\text{CCOOH}$   
 (2)  $\text{HCOOH} > (\text{CH}_3)_3\text{CCOOH} > (\text{CH}_3)_2\text{CHCOOH} > \text{CH}_3\text{COOH}$   
 (3)  $(\text{CH}_3)_3\text{CCOOH} > (\text{CH}_3)_2\text{CHCOOH} > \text{CH}_3\text{COOH} > \text{HCOOH}$   
 (4)  $\text{CH}_3\text{COOH} > (\text{CH}_3)_2\text{CHCOOH} > (\text{CH}_3)_3\text{CCOOH} > \text{HCOOH}$

- 48 Which one of the following reactions does NOT belong to "Lassaigne's test"?

- (1)  $\text{Na} + \text{X} \xrightarrow{\Delta} + \text{NaX}$   
 (2)  $2\text{CuO} + \text{C} \xrightarrow{\Delta} 2\text{Cu} + \text{CO}_2$   
 (3)  $\text{Na} + \text{C} + \text{N} \xrightarrow{\Delta} \text{NaCN}$   
 (4)  $2\text{Na} + \text{S} \xrightarrow{\Delta} \text{Na}_2\text{S}$

- 49 If the rate constant of a reaction is  $0.03 \text{ s}^{-1}$ , how much time does it take for  $7.2 \text{ mol L}^{-1}$  concentration of the reactant to get reduced to  $0.9 \text{ mol L}^{-1}$ ?

(Given:  $\log 2 = 0.301$ )

- (1) 210 s (2) 21.0 s  
 (3) 69.3 s (4) 23.1 s

48\_English ]

- 50 Given below are two statements :

**Statement I :** A hypothetical diatomic molecule with bond order zero is quite stable.

**Statement II :** As bond order increases, the bond length increases.

In the light of the above statements, choose the most appropriate answer from the options given below :

- (1) Statement I is true but Statement II is false  
 (2) Statement I is false but Statement II is true  
 (3) Both Statement I and Statement II are true  
 (4) Both Statement I and Statement II are false

- 51 Out of the following complex compounds, which of the compound will be having the minimum conductance in solution?

- (1)  $[\text{Co}(\text{NH}_3)_6]\text{Cl}_3$   
 (2)  $[\text{Co}(\text{NH}_3)_5\text{Cl}]\text{Cl}$   
 (3)  $[\text{Co}(\text{NH}_3)_3\text{Cl}_3]$   
 (4)  $[\text{Co}(\text{NH}_3)_4\text{Cl}_2]$

- 52 Which of the following aqueous solution will exhibit highest boiling point?

- (1)  $0.01\text{M Na}_2\text{SO}_4$   
 (2)  $0.015\text{M C}_6\text{H}_{12}\text{O}_6$   
 (3)  $0.01\text{M Urea}$   
 (4)  $0.01\text{M KNO}_3$

- 53 Given below are two statements : one is labelled as **Assertion (A)** and the other is labelled as **Reason (R)**.

**Assertion (A) :**  I undergoes  $S_N2$  reaction faster than  Cl.

**Reason (R) :** Iodine is a better leaving group because of its large size.

In the light of the above statements, choose the **correct** answer from the options given below :

- (1) **A** is true but **R** is false
- (2) **A** is false but **R** is true
- (3) Both **A** and **R** are true and **R** is the correct explanation of **A**
- (4) Both **A** and **R** are true but **R** is **not** the correct explanation of **A**

- 54 Consider the following compounds :



The oxidation states of the underlined elements in them are, respectively,

- (1) ~~+1, -2, and +4~~
- (2) +4, -4, and +6
- (3) +1, -1, and +6
- (4) +2, -2, and +6

- 55 Match List - I with List - II

List-I	List-II
A. Haber process	I. Fe catalyst
B. Wacker oxidation	II. $\text{PdCl}_2$
C. Wilkinson catalyst	III. $[(\text{PPh}_3)_3\text{RhCl}]$
D. Ziegler catalyst	IV. $\text{TiCl}_4$ with $\text{Al}(\text{CH}_3)_3$

Choose the **correct** answer from the options given below :

- (1) A-I, B-II, C-III, D-IV
- (2) A-I, B-IV, C-III, D-II
- (3) A-I, B-II, C-IV, D-III
- (4) A-II, B-III, C-I, D-IV

- 56 Given below are two statements :

**Statement I :** Like nitrogen that can form ammonia, arsenic can form arsine.

**Statement II :** Antimony cannot form antimony pentoxide.

In the light of the above statements, choose the **most appropriate** answer from the options given below :

- (1) Statement I is correct but Statement II is incorrect
- (2) Statement I is incorrect but Statement II is correct
- (3) Both Statement I and Statement II are correct
- (4) Both Statement I and Statement II are incorrect

- 57 Given below are two statements :

**Statement I :** Ferromagnetism is considered as an extreme form of paramagnetism.

**Statement II :** The number of unpaired electrons in a  $\text{Cr}^{2+}$  ion ( $Z = 24$ ) is the same as that of a  $\text{Nd}^{3+}$  ion ( $Z = 60$ ).

In the light of the above statements, choose the **correct** answer from the options given below :

- (1) Statement I is true but Statement II is false
- (2) Statement I is false but Statement II is true
- (3) Both Statement I and Statement II are true
- (4) Both Statement I and Statement II are false

58 Which one of the following reactions does NOT give benzene as the product?

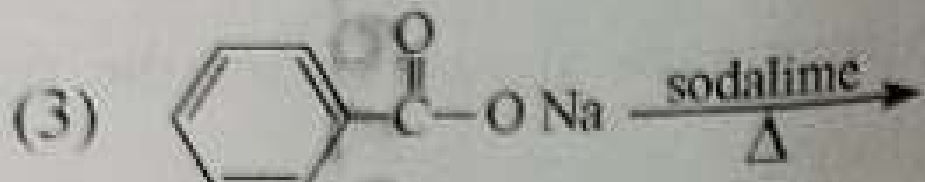
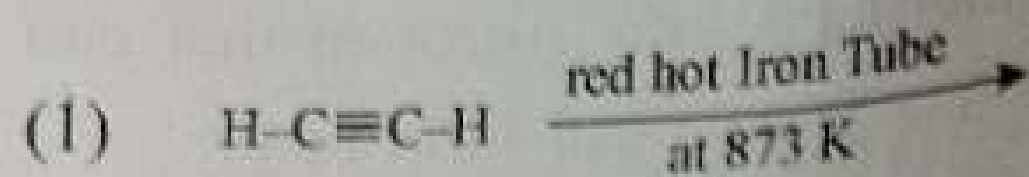

59 Match List - I with List - II

List-I	List-II
A. $\text{XeO}_3$	I. $\text{sp}^3\text{d}$ ; linear
B. $\text{XeF}_2$	II. $\text{sp}^3$ ; pyramidal
C. $\text{XeOF}_4$	III. $\text{sp}^3\text{d}^3$ ; distorted octahedral
D. $\text{XeF}_6$	IV. $\text{sp}^3\text{d}^2$ ; square pyramidal

Choose the correct answer from the options given below:

- (1) A-IV, B-II, C-III, D-I
- (2) A-IV, B-II, C-I, D-III
- (3) A-II, B-I, C-IV, D-III
- (4) A-II, B-I, C-III, D-IV

60 How many products (including stereoisomers) are expected from monochlorination of the following compound?

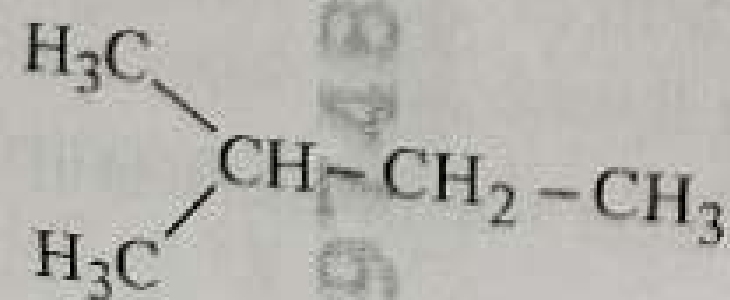

- (1) 5
- (2) 6
- (3) 2
- (4) 3

48\_English ]

61

Which of the following statements are true?

- A. Unlike Ga that has a very high melting point, Cs has a very low melting point.
- B. On Pauling scale, the electronegativity values of N and Cl are not the same.
- C. Ar,  $\text{K}^+$ ,  $\text{Cl}^-$ ,  $\text{Ca}^{2+}$ , and  $\text{S}^{2-}$  are all isoelectronic species.
- D. The correct order of the first ionization enthalpies of Na, Mg, Al, and Si is  $\text{Si} > \text{Al} > \text{Mg} > \text{Na}$ .
- E. The atomic radius of Cs is greater than that of Li and Rb.

Choose the correct answer from the options given below:

- (1) C and D only
- (2) A, C, and E only
- (3) A, B, and E only
- (4) C and E only

62 The standard heat of formation, in kcal/mol of  $\text{Ba}^{2+}$  is:

[Given: standard heat of formation of  $\text{SO}_4^{2-}$  ion (aq) = -216 kcal/mol, standard heat of crystallisation of

$\text{BaSO}_4(\text{s}) = -4.5$  kcal/mol, standard heat of formation of  $\text{BaSO}_4(\text{s}) = -349$  kcal/mol]

- (1) +133.0
- (2) +220.5
- (3) -128.5
- (4) -133.0

63 Match List - I with List - II

List-I	List-II
(Example)	(Type of Solution)
A. Humidity	I. Solid in solid
B. Alloys	II. Liquid in gas
C. Amalgams	III. Solid in gas
D. Smoke	IV. Liquid in solid

Choose the correct answer from the options given below:

- (1) A-III, B-I, C-IV, D-II
- (2) A-III, B-II, C-I, D-IV
- (3) A-II, B-IV, C-I, D-III
- (4) A-II, B-I, C-IV, D-III

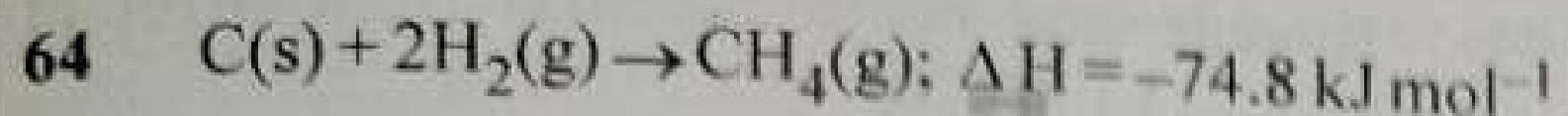

Which of the following diagrams gives an accurate representation of the above reaction?

[R  $\rightarrow$  reactants; P  $\rightarrow$  products]

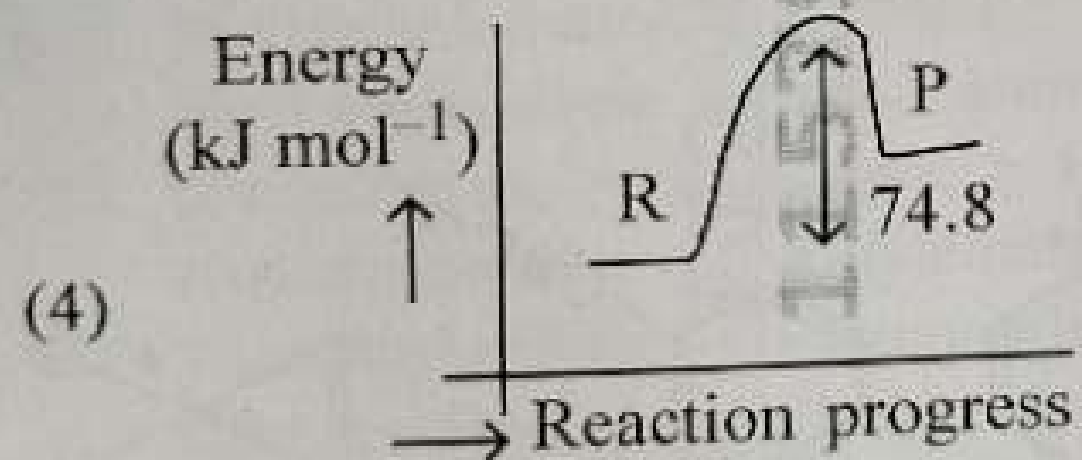
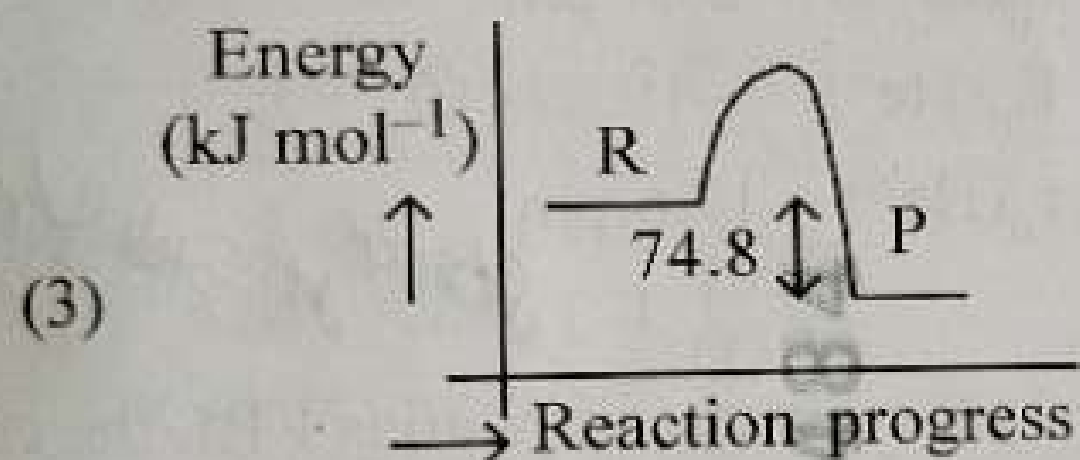
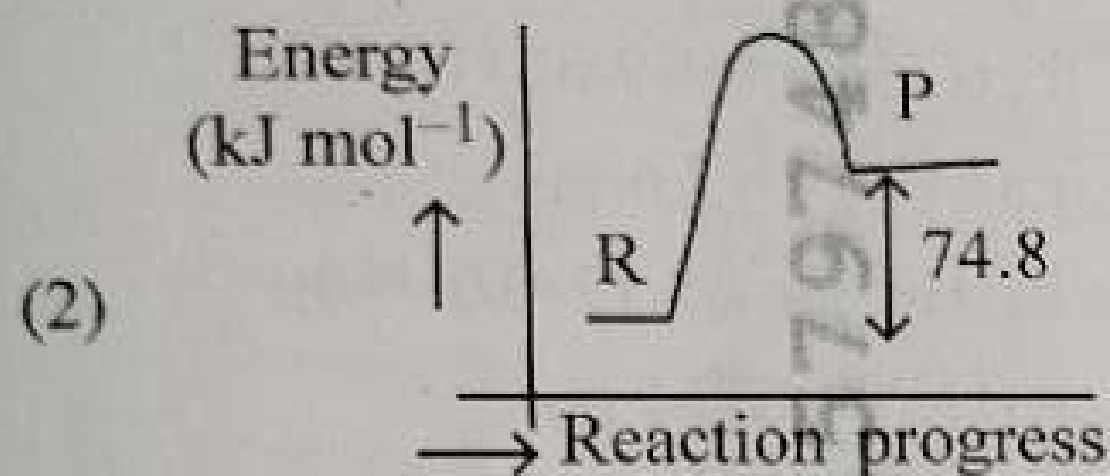
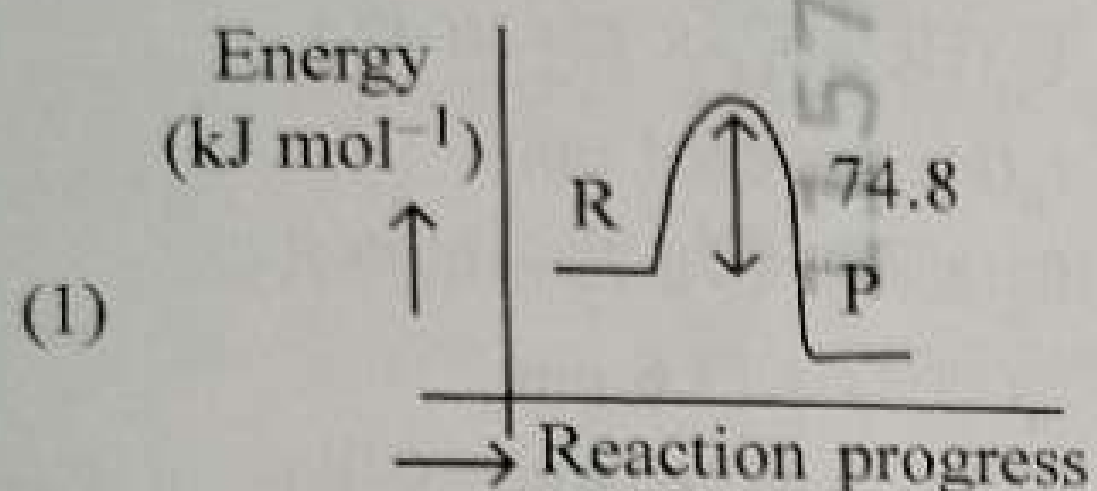

65 Sugar 'X'

- A. is found in honey.
- B. is a keto sugar.
- C. exists in  $\alpha$  and  $\beta$  - anomeric forms.
- D. is laevorotatory.

'X' is :

- (1) Maltose
- (2) Sucrose
- (3) D-Glucose
- (4) D-Fructose

66 Total number of possible isomers (both structural as well as stereoisomers) of cyclic ethers of molecular formula  $C_4H_8O$  is :

- (1) 10
- (2) 11
- (3) 6
- (4) 8

67 For the reaction  $A(g) \rightleftharpoons 2B(g)$ , the backward reaction rate constant is higher than the forward reaction rate constant by a factor of 2500, at 1000 K.

[Given :  $R = 0.0831 \text{ L atm mol}^{-1} \text{ K}^{-1}$ ]

$K_p$  for the reaction at 1000 K is

- (1) 0.033
- (2) 0.021
- (3) 83.1
- (4)  $2.077 \times 10^5$

68 The ratio of the wavelengths of the light absorbed by a Hydrogen atom when it undergoes  $n = 2 \rightarrow n = 3$  and  $n = 4 \rightarrow n = 6$  transitions, respectively, is

- (1)  $\frac{1}{9}$
- (2)  $\frac{1}{4}$
- (3)  $\frac{1}{36}$
- (4)  $\frac{1}{16}$

69 If the molar conductivity ( $\Lambda_m$ ) of a  $0.050 \text{ mol L}^{-1}$  solution of a monobasic weak acid is  $90 \text{ S cm}^2 \text{ mol}^{-1}$ , its extent (degree) of dissociation will be

[Assume  $\Lambda_+^\circ = 349.6 \text{ S cm}^2 \text{ mol}^{-1}$  and

$\Lambda_-^\circ = 50.4 \text{ S cm}^2 \text{ mol}^{-1}$ .]

- (1) 0.225
- (2) 0.215
- (3) 0.115
- (4) 0.125

70 5 moles of liquid X and 10 moles of liquid Y make a solution having a vapour pressure of 70 torr. The vapour pressures of pure X and Y are 63 torr and 78 torr respectively. Which of the following is true regarding the described solution?

- (1) The solution is ideal.
- (2) The solution has volume greater than the sum of individual volumes.
- (3) The solution shows positive deviation.
- (4) The solution shows negative deviation.

71 Among the following, choose the ones with equal number of atoms.

- A. 212 g of  $\text{Na}_2\text{CO}_3$  (s) [molar mass = 106 g]
- B. 248 g of  $\text{Na}_2\text{O}$  (s) [molar mass = 62 g]
- C. 240 g of  $\text{NaOH}$  (s) [molar mass = 40 g]
- D. 12 g of  $\text{H}_2$  (g) [molar mass = 2 g]
- E. 220 g of  $\text{CO}_2$  (g) [molar mass = 44 g]

Choose the correct answer from the options given below :

- (1) B, C, and D only
- (2) B, D, and E only
- (3) A, B, and C only
- (4) A, B, and D only

72 Which of the following are paramagnetic?

- A.  $[\text{NiCl}_4]^{2-}$       B.  $[\text{Ni}(\text{CO})_4]$       23
- C.  $[\text{Ni}(\text{CN})_4]^{2-}$       D.  $[\text{Ni}(\text{H}_2\text{O})_6]^{2+}$
- E.  $\text{Ni}(\text{PPh}_3)_4$       

Choose the correct answer from the options given below:

- (1) A and D only
- (2) A, D and E only
- (3) A and C only
- (4) B and E only

73 If the half-life ( $t_{1/2}$ ) for a first order reaction is 1 minute, then the time required for 99.9% completion of the reaction is closest to :

- (1) 5 minutes
- (2) 10 minutes
- (3) 2 minutes
- (4) 4 minutes

48\_English ]

74 Energy and radius of first Bohr orbit of  $\text{He}^+$  and  $\text{Li}^{2+}$  are

[Given  $R_H = 2.18 \times 10^{-18}$  J,  $a_0 = 52.9$  pm]

(1)  $E_n(\text{Li}^{2+}) = -19.62 \times 10^{-16}$  J;

$r_n(\text{Li}^{2+}) = 17.6$  pm

$E_n(\text{He}^+) = -8.72 \times 10^{-16}$  J;

$r_n(\text{He}^+) = 26.4$  pm

(2)  $E_n(\text{Li}^{2+}) = -8.72 \times 10^{-16}$  J;

$r_n(\text{Li}^{2+}) = 17.6$  pm

$E_n(\text{He}^+) = -19.62 \times 10^{-16}$  J;

$r_n(\text{He}^+) = 17.6$  pm

(3)  $E_n(\text{Li}^{2+}) = +19.62 \times 10^{-18}$  J;

$r_n(\text{Li}^{2+}) = 17.6$  pm

$E_n(\text{He}^+) = -8.72 \times 10^{-18}$  J;

$r_n(\text{He}^+) = 26.4$  pm

(4)  $E_n(\text{Li}^{2+}) = -8.72 \times 10^{-18}$  J;

$r_n(\text{Li}^{2+}) = 26.4$  pm

$E_n(\text{He}^+) = -19.62 \times 10^{-18}$  J;

$r_n(\text{He}^+) = 17.6$  pm

*Job*

*Stable ya stable karo*

75 Among the given compounds I-III, the correct order of bond dissociation energy of C-H bond marked with \* is :

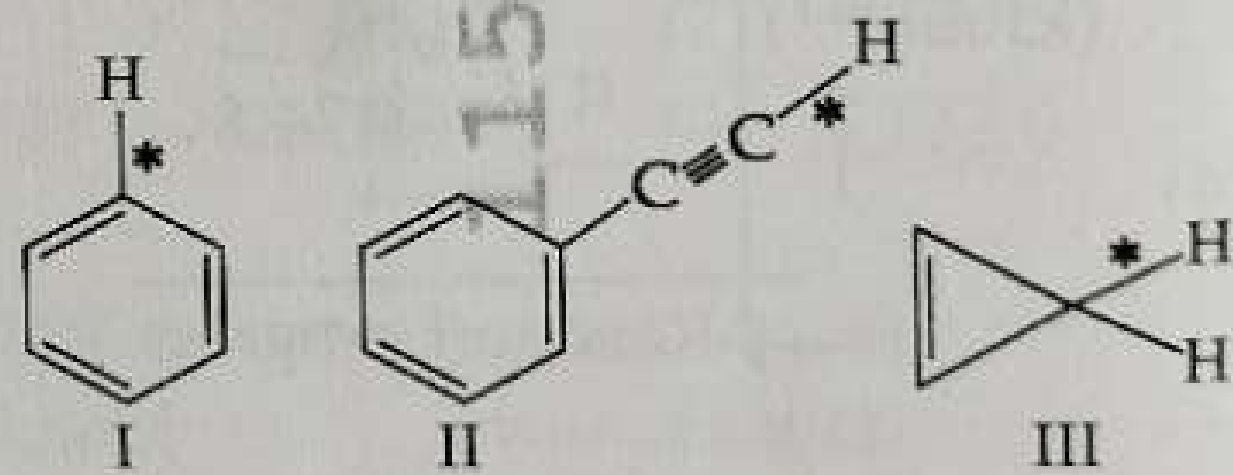

- (1) III > II > I
- (2) II > III > I
- (3) II > I > III
- (4) I > II > III

76 Dalton's Atomic theory could not explain which of the following?

- (1) Law of multiple proportion
- (2) Law of gaseous volume
- (3) Law of conservation of mass
- (4) Law of constant proportion

77 Identify the correct orders against the property mentioned

- A.  $H_2O > NH_3 > CHCl_3$  - dipole moment  
 B.  $XeF_4 > XeO_3 > XeF_2$  - number of lone pairs on central atom  
 C.  $O-H > C-H > N-O$  - bond length  
 D.  $N_2 > O_2 > H_2$  - bond enthalpy

Choose the **correct** answer from the options given below :

- (1) A, C only      (2) B, C only  
 (3) A, D only      (4) B, D only

78 Match List I with List II.

List I (Name of Vitamin)	List II (Deficiency disease)
A. Vitamin B <sub>12</sub>	I. Cheilosis
B. Vitamin D	II. Convulsions
C. Vitamin B <sub>2</sub>	III. Rickets
D. Vitamin B <sub>6</sub>	IV. Pernicious anaemia

Choose the **correct** answer from the options given below :

- (1) A-II, B-III, C-I, D-IV  
 (2) A-IV, B-III, C-II, D-I  
 (3) A-I, B-III, C-II, D-IV  
 (4) A-IV, B-III, C-I, D-II

79 The correct order of decreasing basic strength of the given amines is :

- (1) N-ethylethanamine > ethanamine > N-methylaniline > benzenamine  
 (2) benzenamine > ethanamine > N-methylaniline > N-ethylethanamine  
 (3) N-methylaniline > benzenamine > ethanamine > N-ethylethanamine  
 (4) N-ethylethanamine > ethanamine > benzenamine > N-methylaniline





80 The correct order of the wavelength of light absorbed by the following complexes is,

- A.  $[Co(NH_3)_6]^{3+}$       B.  $[Co(CN)_6]^{3-}$   
 C.  $[Cu(H_2O)_4]^{2+}$       D.  $[Ti(H_2O)_6]^{3+}$

Choose the **correct** answer from the options given below:

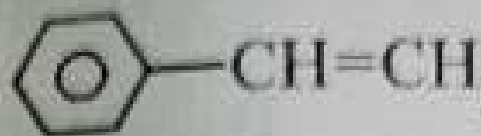
- (1)  $C < D < A < B$       (2)  $C < A < D < B$   
 (3)  $B < D < A < C$       (4)  $B < A < D < C$

81 Which one of the following compounds **does not** decolourize bromine water?

- (1)   
 (2)   
 (3)   
 (4) 

82 Predict the major product 'P' in the following sequence of reactions -

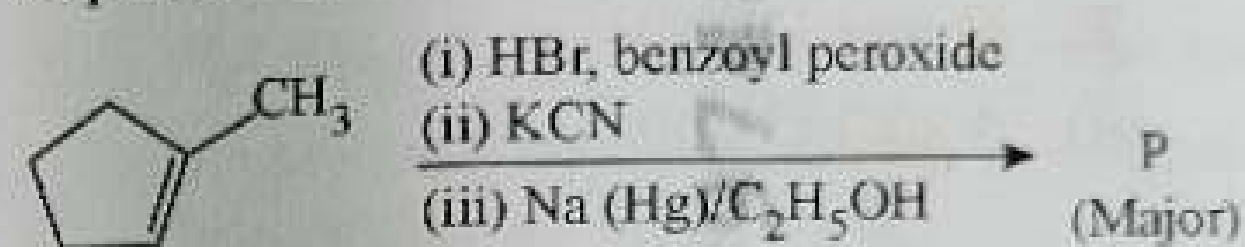

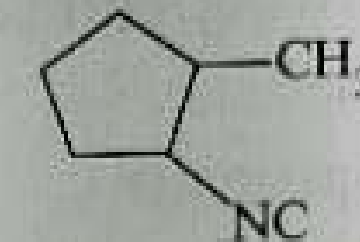
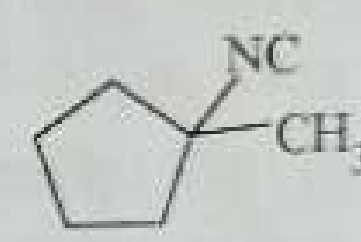
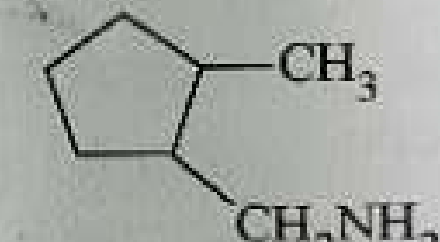
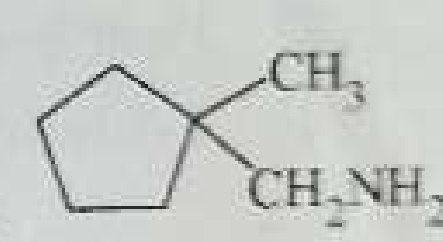
- (1)       (2)   
 (3)       (4) 

83 Match List I with List II

List I (Mixture)	List II (Method of Separation)
A. $CHCl_3 + C_6H_5NH_2$	I. Distillation under reduced pressure
B. Crude oil in petroleum industry	II. Steam distillation
C. Glycerol from spent-lye	III. Fractional distillation
D. Aniline - water	IV. Simple distillation

Choose the **correct** answer from the options given below :

- (1) A-III, B-IV, C-I, D-II  
 (2) A-III, B-IV, C-II, D-I  
 (3) A-IV, B-III, C-I, D-II  
 (4) A-IV, B-III, C-II, D-I

84 Which among the following electronic configurations belong to main group elements?

- A.  $[\text{Ne}]3s^1$       B.  $[\text{Ar}]3d^3 4s^2$   
 C.  $[\text{Kr}]4d^{10} 5s^2 5p^5$       D.  $[\text{Ar}]3d^{10} 4s^1$   
 E.  $[\text{Rn}]5f^0 6d^2 7s^2$

Choose the correct answer from the option given below :

- (1) D and E only  
 (2) A, C and D only  
 (3) B and E only  
 (4) A and C only

85 Which one of the following compounds can exist as cis-trans isomers?

- (1) 1,1-Dimethylcyclopropane  
 (2) 1,2-Dimethylcyclohexane  
 (3) Pent-1-ene  
 (4) 2-Methylhex-2-ene

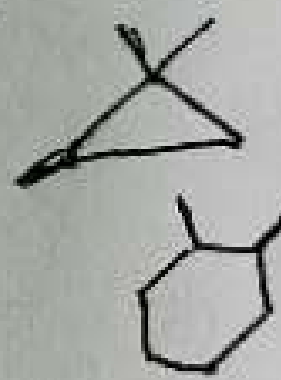

86 Phosphoric acid ionizes in three steps with their ionization constant values

$K_{a_1}$ ,  $K_{a_2}$  and  $K_{a_3}$ , respectively,

while  $K$  is the overall ionization constant.

Which of the following statements are true?

- A.  $\log K = \log K_{a_1} + \log K_{a_2} + \log K_{a_3}$   
 B.  $\text{H}_3\text{PO}_4$  is a stronger acid than  $\text{H}_2\text{PO}_4^-$  and  $\text{HPO}_4^{2-}$ .  
 C.  $K_{a_1} > K_{a_2} > K_{a_3}$   
 D.  $K_{a_1} = \frac{K_{a_3} + K_{a_2}}{2}$

Choose the correct answer from the options given below:

- (1) B, C and D only  
 (2) A, B and C only  
 (3) A and B only  
 (4) A and C only

48\_English ]

87 Match List I with List II

List I  
(Ion)

List II

(Group Number in Cation Analysis)

- |                     |               |
|---------------------|---------------|
| A. $\text{Co}^{2+}$ | I. Group-I    |
| B. $\text{Mg}^{2+}$ | II. Group-III |
| C. $\text{Pb}^{2+}$ | III. Group-IV |
| D. $\text{Al}^{3+}$ | IV. Group-VI  |

Choose the correct answer from the options given below :

- (1) A-III, B-II, C-IV, D-I  
 (2) A-III, B-II, C-I, D-IV  
 (3) A-III, B-IV, C-II, D-I  
 (4) A-III, B-IV, C-I, D-II

88 Higher yield of NO in

$\text{N}_2(\text{g}) + \text{O}_2(\text{g}) \rightleftharpoons 2\text{NO}(\text{g})$  can be obtained at

$[\Delta H \text{ of the reaction} = + 180.7 \text{ kJ mol}^{-1}]$

- A. higher temperature  
 B. lower temperature  
 C. higher concentration of  $\text{N}_2$   
 D. higher concentration of  $\text{O}_2$

Choose the correct answer from the options given below:

- (1) B, C, D only  
 (2) A, C, D only  
 (3) A, D only  
 (4) B, C only

89 Given below are two statements :

**Statement I :** Benzenediazonium salt is prepared by the reaction of aniline with nitrous acid at 273 - 278 K. It decomposes easily in the dry state.

**Statement II :** Insertion of iodine into the benzene ring is difficult and hence iodobenzene is prepared through the reaction of benzenediazonium salt with KI.

In the light of the above statements, choose the **most appropriate** answer from the options given below :

- (1) Statement I is correct but Statement II is incorrect
- (2) Statement I is incorrect but Statement II is correct
- (3) Both Statement I and Statement II are correct
- (4) Both Statement I and Statement II are incorrect

90 The major product of the following reaction is:

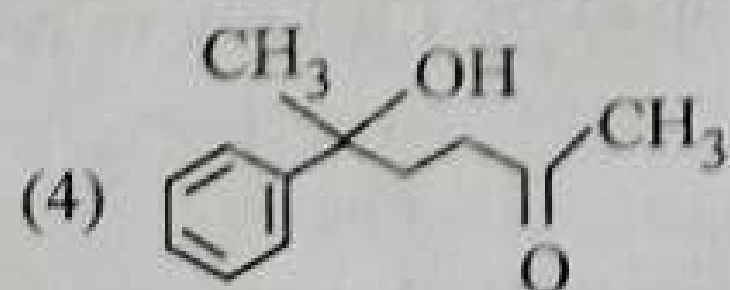
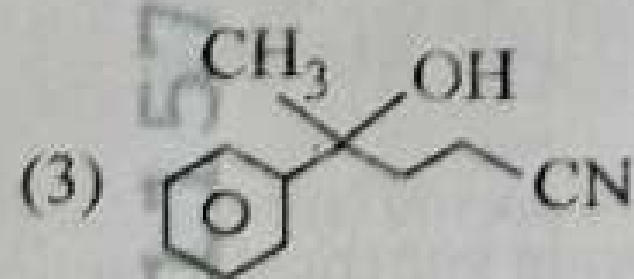
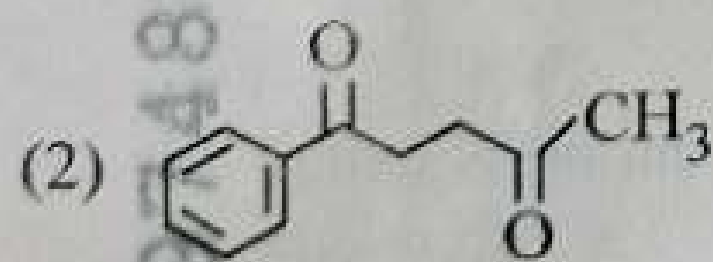
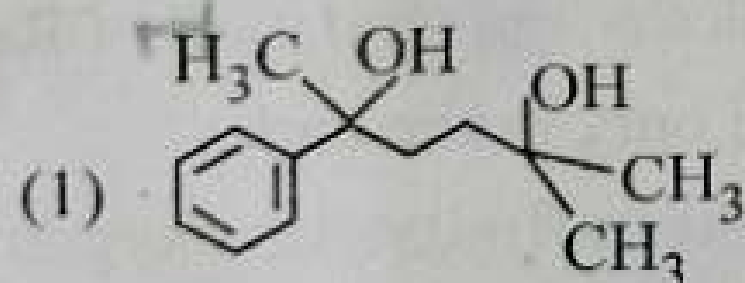
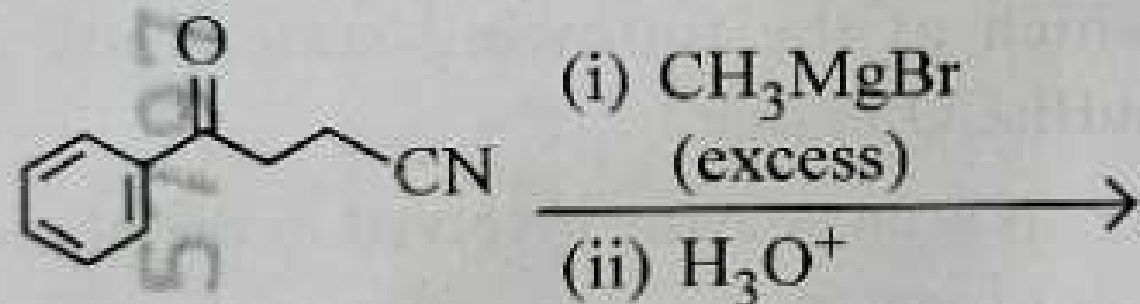

91

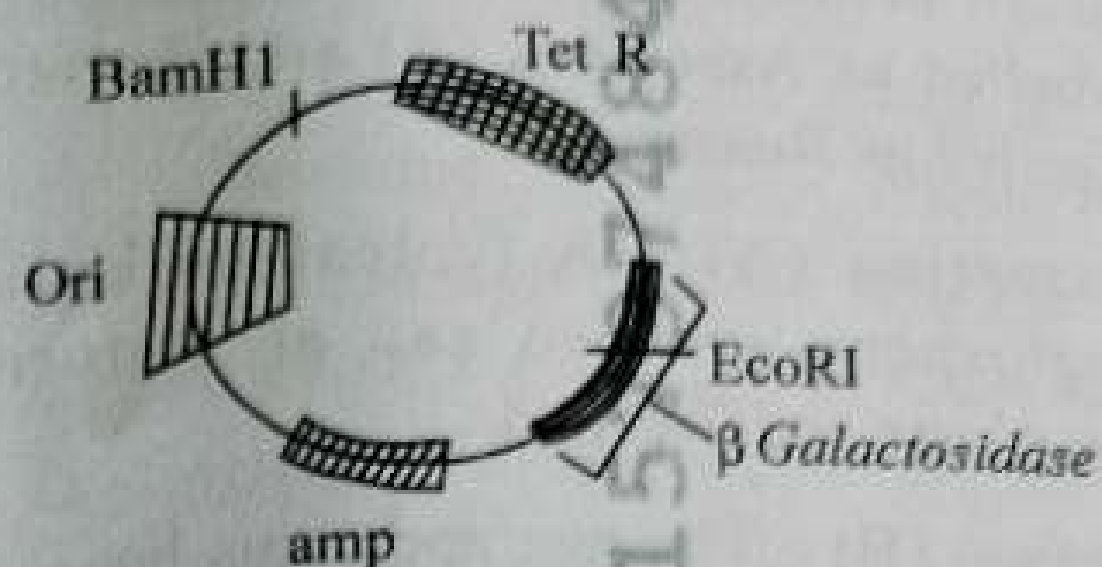

In the above represented plasmid an alien piece of DNA is inserted at EcoRI site. Which of the following strategies will be chosen to select the recombinant colonies?

- (1) White color colonies will be selected.
- (2) Blue color colonies grown on ampicillin plates can be selected.
- (3) Using ampicillin & tetracyclin containing medium plate.
- (4) Blue color colonies will be selected.

92 The protein portion of an enzyme is called :

- (1) Apoenzyme
- (2) Prosthetic group
- (3) Cofactor
- (4) Coenzyme

93 Given below are two statements :

**Statement I :** The primary source of energy in an ecosystem is solar energy.

**Statement II :** The rate of production of organic matter during photosynthesis in an ecosystem is called net primary productivity (NPP).

In the light of the above statements, choose the **most appropriate** answer from the options given below :

- (1) Statement I is correct but statement II is incorrect
- (2) Statement I is incorrect but statement II is correct
- (3) Both statement I and statement II are correct
- (4) Both statement I and statement II are incorrect

94 Given below are two statements : One is labelled as Assertion (A) and the other is labelled as Reason (R).

**Assertion (A) :** A typical unfertilised, angiosperm embryo sac at maturity is 8 nucleate and 7-celled.

**Reason (R) :** The egg apparatus has 2 polar nuclei.

In the light of the above statements, choose the correct answer from the options given below :

- (1) A is true but R is false
- (2) A is false but R is true
- (3) Both A and R are true and R is the correct explanation of A
- (4) Both A and R are true but R is NOT the correct explanation of A

95 Neoplastic characteristics of cells refer to :

- A. A mass of proliferating cell
- B. Rapid growth of cells
- C. Invasion and damage to the surrounding tissue
- D. Those confined to original location

Choose the correct answer from the options given below:

- (1) A, B, D only
- (2) B, C, D only
- (3) A, B only
- (4) A, B, C only

96 Which one of the following is the characteristic feature of gymnosperms?

- (1) Seeds are absent.
- (2) Gymnosperms have flowers for reproduction.
- (3) Seeds are enclosed in fruits.
- (4) Seeds are naked.

97 Match List - I with List - II.

- List - I**
- A. Progesterone
  - B. Relaxin
  - C. Melanocyte stimulating hormone
  - D. Catecholamines

- List - II**
- I. Pars intermedia
  - II. Ovary
  - III. Adrenal Medulla
  - IV. Corpus luteum

Choose the correct answer from the options given below :

- (1) A-II, B-IV, C-I, D-III
- (2) A-III, B-II, C-IV, D-I
- (3) A-IV, B-II, C-I, D-III
- (4) A-IV, B-II, C-III, D-I

98 Which chromosome in the human genome has the highest number of genes?

- (1) Chromosome 1
- (2) Chromosome 10
- (3) Chromosome X
- (4) Chromosome Y

99 Which of the following statements about RuBisCO is true?

- (1) It is an enzyme involved in the photolysis of water.
- (2) It catalyzes the carboxylation of RuBP.
- (3) It is active only in the dark.
- (4) It has higher affinity for oxygen than carbon dioxide.

100 The first menstruation is called :

- (1) Diapause
- (2) Ovulation
- (3) Menopause
- (4) Menarche

101 Which of the following genetically engineered organisms was used by Eli Lilly to prepare human insulin?

- (1) Virus
- (2) Phage
- (3) Bacterium
- (4) Yeast

102 Given below are two statements : one is labelled as **Assertion (A)** and the other is labelled as **Reason (R)**.

**Assertion (A)** : All vertebrates are chordates but all chordates are not vertebrate.

**Reason (R)** : The members of subphylum vertebrata possess notochord during the embryonic period, the notochord is replaced by a cartilaginous or bony vertebral column in adults.

In the light of the above statements, choose the **correct** answer from the options given below :

- (1) A is true but R is false
- (2) A is false but R is true
- (3) Both A and R are true and R is the correct explanation of A
- (4) Both A and R are true but R is not the correct explanation of A

103 What is the main function of the spindle fibers during mitosis ?

- (1) To repair damaged DNA
- (2) To regulate cell growth
- (3) To separate the chromosomes
- (4) To synthesize new DNA

104 Match List I with List II :

List-I	List-II
A. Alfred Hershey and Martha Chase	I. Streptococcus pneumoniae
B. Euchromatin	II. Densely packed and dark-stained
C. Frederick Griffith	III. Loosely packed and light-stained
D. Heterochromatin	IV. DNA as genetic material confirmation

Choose the **correct** answer from the options given below :

- (1) A-IV, B-III, C-I, D-II
- (2) A-III, B-II, C-IV, D-I
- (3) A-II, B-IV, C-I, D-III
- (4) A-IV, B-II, C-I, D-III

105 Match List I with List II.

List I	List II
A. Adenosine	I. Nitrogen base
B. Adenylic acid	II. Nucleotide
C. Adenine	III. Nucleoside
D. Alanine	IV. Amino acid

Choose the option with all **correct** matches.

- (1) A-III, B-II, C-I, D-IV
- (2) A-II, B-III, C-I, D-IV
- (3) A-III, B-IV, C-II, D-I
- (4) A-III, B-II, C-IV, D-I

106 In frog, the Renal portal system is a special venous connection that acts to link :

- (1) Kidney and intestine
- (2) Kidney and lower part of body
- (3) Liver and intestine
- (4) Liver and kidney

107 Which of the following are the post-transcriptional events in an eukaryotic cell?

- A. Transport of pre-mRNA to cytoplasm prior to splicing.
- B. Removal of introns and joining of exons.
- C. Addition of methyl group at 5' end of hnRNA.
- D. Addition of adenine residues at 3' end of hnRNA.
- E. Base pairing of two complementary RNAs.

Choose the **correct** answer from the options given below :

- (1) B, C, E only
- (2) C, D, E only
- (3) A, B, C only
- (4) B, C, D only

108 Polymerase chain reaction (PCR) amplifies DNA following the equation.

- (1)  $2n + 1$
- (2)  $2N^2$
- (3)  $N^2$
- (4)  $2^n$

109 Given below are two statements : One is labelled as **Assertion (A)** and the other is labelled as **Reason (R)**.

**Assertion (A)** : Both wind and water pollinated flowers are not very colourful and do not produce nectar.

**Reason (R)** : The flowers produce enormous amount of pollen grains in wind and water pollinated flowers.

In the light of the above statements, choose the correct answer from the options given below:

- (1) A is true but R is false
- (2) A is false but R is true
- (3) Both A and R are true and R is the correct explanation of A
- (4) Both A and R are true but R is **NOT** the correct explanation of A

110 Epiphytes that are growing on a mango branch is an example of which of the following?

- (1) Predation
- (2) Amensalism
- (3) Commensalism
- (4) Mutualism

111 Find the correct statements :

- A. In human pregnancy, the major organ systems are formed at the end of 12 weeks.
- B. In human pregnancy the major organ systems are formed at the end of 8 weeks.
- C. In human pregnancy heart is formed after one month of gestation.
- D. In human pregnancy, limbs and digits develop by the end of second month.
- E. In human pregnancy the appearance of hair is usually observed in the fifth month.

Choose the **correct** answer from the options given below :

- (1) B, C, D and E Only
- (2) A, C, D and E Only
- (3) A and E Only
- (4) B and C Only

112 Identify the part of a bio-reactor which is used as a foam breaker from the given figure.

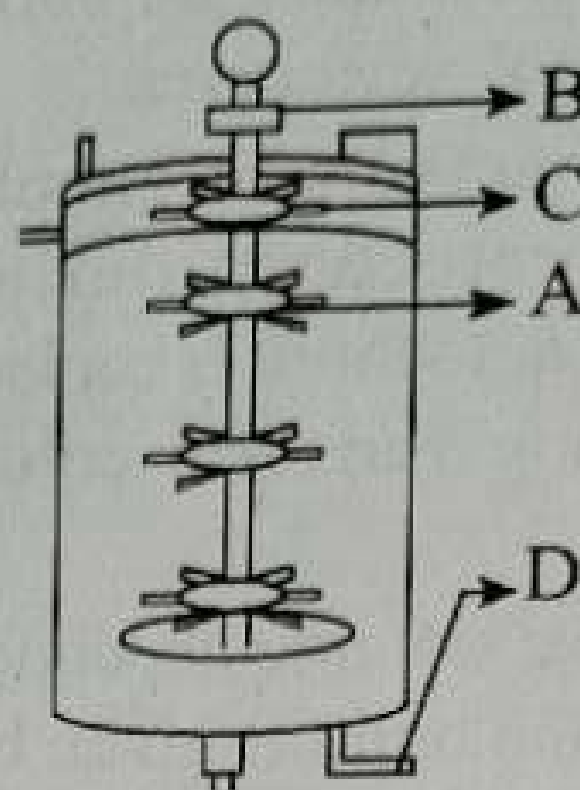

- (1) D
- (2) C
- (3) A
- (4) B

113 Frogs respire in water by skin and buccal cavity and on land by skin, buccal cavity and lungs.

Choose the **correct** answer from the following :

- (1) The statement is false for water but true for land
- (2) The statement is false for both the environment
- (3) The statement is true for water but false for land
- (4) The statement is true for both the environment

114 Consider the following statements regarding function of adrenal medullary hormones :

- A. It causes pupillary constriction
- B. It is a hyperglycemic hormone
- C. It causes piloerection
- D. It increases strength of heart contraction

Choose the **correct** answer from the options given below :

- (1) A, C and D Only
- (2) D Only
- (3) C and D Only
- (4) B, C and D Only

115 Read the following statements on plant growth and development.

- A. Parthenocarpy can be induced by auxins.
- B. Plant growth regulators can be involved in promotion as well as inhibition of growth.
- C. Dedifferentiation is a pre-requisite for re-differentiation.
- D. Abscisic acid is a plant growth promoter.
- E. Apical dominance promotes the growth of lateral buds.

Choose the option with all correct statements.

- (1) A, D, E only
- (2) B, D, E only
- (3) A, B, C only
- (4) A, C, E only

116 Which of the following hormones released from the pituitary is actually synthesized in the hypothalamus ?

- (1) Follicle-stimulating hormone (FSH)
- (2) Adenocorticotrophic hormone (ACTH)
- (3) Luteinizing hormone (LH)
- (4) Anti-diuretic hormone (ADH)

117 Which of the following is an example of non-distilled alcoholic beverage produced by yeast?

- (1) Beer
- (2) Rum
- (3) Whisky
- (4) Brandy

118 What is the pattern of inheritance for polygenic trait?

- (1) Autosomal dominant pattern
- (2) X-linked recessive inheritance pattern
- (3) Mendelian inheritance pattern
- (4) Non-mendelian inheritance pattern

119 Match List - I with List - II.

List - I	List - II
A. Head	I. Enzymes
B. Middle piece	II. Sperm motility
C. Acrosome	III. Energy
D. Tail	IV. Genetic material

Choose the **correct** answer from the options given below :

- (1) A-III, B-IV, C-II, D-I
- (2) A-III, B-II, C-I, D-IV
- (3) A-IV, B-III, C-I, D-II
- (4) A-IV, B-III, C-II, D-I

120 Which of the following is an example of a zygomorphic flower?

- (1) Pea
- (2) Chilli
- (3) Petunia
- (4) Datura

121 Which of following organisms *cannot* fix nitrogen?

- A. *Azotobacter*
- B. *Oscillatoria*
- C. *Anabaena*
- D. *Volvox*
- E. *Nostoc*

Choose the **correct** answer from the options given below:

- (1) B only
- (2) E only
- (3) A only
- (4) D only

122 Which one of the following is an example of ex-situ conservation?

- (1) Zoos and botanical gardens
- (2) Protected areas
- (3) National Park
- (4) Wildlife Sanctuary

123 Who is known as the father of Ecology in India?

- (1) Ram Udar
- (2) Birbal Sahni
- (3) S. R. Kashyap
- (4) Ramdeo Misra

[ Contd...

124 Given below are two statements :

**Statement I :** In the RNA world, RNA is considered the first genetic material evolved to carry out essential life processes. RNA acts as a genetic material and also as a catalyst for some important biochemical reactions in living systems. Being reactive, RNA is unstable.

**Statement II :** DNA evolved from RNA and is a more stable genetic material. Its double helical strands being complementary, resist changes by evolving repairing mechanism.

In the light of the above statements, choose the **most appropriate** answer from the options given below :

- (1) Statement I is correct but statement II is incorrect
- (2) Statement I is incorrect but statement II is correct
- (3) Both statement I and statement II are correct
- (4) Both statement I and statement II are incorrect

125 Given below are two statements :

**Statement I :** Transfer RNAs and ribosomal RNA do not interact with mRNA.

**Statement II :** RNA interference (RNAi) takes place in all eukaryotic organisms as a method of cellular defence.

In the light of the above statements, choose the **most appropriate** answer from the options given below :

- (1) Statement I is correct but Statement II is incorrect
- (2) Statement I is incorrect but Statement II is correct
- (3) Both Statement I and Statement II are correct
- (4) Both Statement I and Statement II are incorrect

126 Match List - I with List - II.

**List - I**

- A. Heart
- B. Kidney
- C. Gastro-intestinal tract
- D. Adrenal Cortex

**List - II**

- I. Erythropoietin
- II. Aldosterone
- III. Atrial natriuretic factor
- IV. Secretin

Choose the **correct** answer from the options given below :

- (1) A-I, B-III, C-IV, D-II
- (2) A-III, B-I, C-IV, D-II
- (3) A-II, B-I, C-III, D-IV
- (4) A-IV, B-III, C-II, D-I

127 All living members of the class Cyclostomata are:

- (1) Symbiotic
- (2) Ectoparasite
- (3) Free living
- (4) Endoparasite

128 ✓ Streptokinase produced by *bacterium Streptococcus* is used for

- (1) Liver disease treatment
- (2) Removing clots from blood vessels
- (3) Curd production
- (4) Ethanol production

129 Role of the water vascular system in Echinoderms is :

- A. Respiration and Locomotion
- B. Excretion and Locomotion
- C. Capture and transport of food
- D. Digestion and Respiration
- E. Digestion and Excretion

Choose the **correct** answer from the options given below :

- (1) B and C Only
- (2) B, D and E Only
- (3) A and B Only
- (4) A and C Only

130 Match List I with List II.

List I	List II
A. Pteridophyte	I. <i>Salvia</i>
B. Bryophyte	II. <i>Ginkgo</i>
C. Angiosperm	III. <i>Polytrichum</i>
D. Gymnosperm	IV. <i>Salvinia</i>

Choose the option with all correct matches.

- (1) A-III, B-IV, C-I, D-II
- (2) A-IV, B-III, C-II, D-I
- (3) A-III, B-IV, C-II, D-I
- (4) A-IV, B-III, C-I, D-II

131 Which are correct:

- Computed tomography and magnetic resonance imaging detect cancers of internal organs.
- Chemotherapeutic drugs are used to kill non-cancerous cells.
- $\alpha$ -interferon activate the cancer patients' immune system and helps in destroying the tumour.
- Chemotherapeutic drugs are biological response modifiers.
- In the case of leukaemia blood cell counts are decreased.

Choose the correct answer from the options given below:

- (1) C and D only
- (2) A and C only
- (3) B and D only
- (4) D and E only

132 What are the potential drawbacks in adoption of the IVF method?

- High fatality risk to mother
- Expensive instruments and reagents
- Husband/wife necessary for being donors
- Less adoption of orphans
- Not available in India
- Possibility that the early embryo does not survive

Choose the correct answer from the options given below :

- (1) A, B, C, D only
- (2) A, B, C, E, F only
- (3) B, D, F only
- (4) A, C, D, F only

133 Consider the following :

- The reductive division for the human female gametogenesis starts earlier than that of the male gametogenesis.
- The gap between the first meiotic division and the second meiotic division is much shorter for males compared to females.
- The first polar body is associated with the formation of the primary oocyte.
- Luteinizing Hormone (LH) surge leads to disintegration of the endometrium and onset of menstrual bleeding.

Choose the correct answer from the options given below :

- (1) B and D are true
- (2) B and C are true
- (3) A and B are true
- (4) A and C are true

134 In bryophytes, the gemmae help in which one of the following?

- (1) Nutrient absorption
- (2) Gaseous exchange
- (3) Sexual reproduction
- (4) Asexual reproduction

135 Given below are two statements : one is labelled as **Assertion (A)** and the other is labelled as **Reason (R)**.

**Assertion (A)** : The primary function of the Golgi apparatus is to package the materials made by the endoplasmic reticulum and deliver it to intracellular targets and outside the cell.

**Reason (R)** : Vesicles containing materials made by the endoplasmic reticulum fuse with the cis face of the Golgi apparatus, and they are modified and released from the trans face of the Golgi apparatus.

In the light of the above statements, choose the correct answer from the options given below :

- (1) A is true but R is false
- (2) A is false but R is true
- (3) Both A and R are true and R is the correct explanation of A
- (4) Both A and R are true but R is not the correct explanation of A

136 Which one of the following statements refers to Reductionist Biology?

- (1) Chemical approach to study and understand living organisms.
- (2) Behavioural approach to study and understand living organisms.
- (3) Physico-chemical approach to study and understand living organisms.
- (4) Physiological approach to study and understand living organisms.

137 After maturation, in primary lymphoid organs, the lymphocytes migrate for interaction with antigens to secondary lymphoid organ(s) / tissue(s) like:

- |                    |                |
|--------------------|----------------|
| A. thymus          | B. bone marrow |
| C. spleen          | D. lymph nodes |
| E. Peyer's patches |                |

Choose the *correct* answer from the options given below:

- (1) E, A, B only
- (2) C, D, E only
- (3) B, C, D only
- (4) A, B, C only

138 Match List I with List II :

List I	List II
A. The Evil Quartet	I. Cryopreservation
B. Ex situ conservation	II. Alien species invasion
C. <i>Lantana camara</i>	III. Causes of biodiversity losses
D. Dodo	IV. Extinction

Choose the option with all correct matches.

- (1) A-III, B-IV, C-II, D-I
- (2) A-III, B-II, C-IV, D-I
- (3) A-III, B-II, C-I, D-IV
- (4) A-III, B-I, C-II, D-IV

139 How many meiotic and mitotic divisions need to occur for the development of a mature female gametophyte from the megaspore mother cell in an angiosperm plant?

- (1) 1 Meiosis and 3 Mitosis
- (2) No Meiosis and 2 Mitosis
- (3) 2 Meiosis and 3 Mitosis
- (4) 1 Meiosis and 2 Mitosis

140 Which of the following type of immunity is present at the time of birth and is a non-specific type of defence in the human body?

- (1) Cell-mediated Immunity
- (2) Humoral Immunity
- (3) Acquired Immunity
- (4) Innate Immunity

141 Given below are two statements :

**Statement I :** Fig fruit is a non-vegetarian fruit as it has enclosed fig wasps in it.

**Statement II :** Fig wasp and fig tree exhibit mutual relationship as fig wasp completes its life cycle in fig fruit and fig fruit gets pollinated by fig wasp.

In the light of the above statements, choose the **most appropriate** answer from the options given below :

- (1) Statement I is correct but statement II is incorrect
- (2) Statement I is incorrect but statement II is correct
- (3) Both statement I and statement II are correct
- (4) Both statement I and statement II are incorrect

142 Given below are two statements : One is labelled as **Assertion (A)** and the other is labelled as **Reason (R)**.

**Assertion (A)** : Cells of the tapetum possess dense cytoplasm and generally have more than one nucleus.

**Reason (R)** : Presence of more than one nucleus in the tapetum increases the efficiency of nourishing the developing microspore mother cells.

In light of the above statements, choose the **most appropriate** answer from the options given below :

- (1) A is true but R is false
- (2) A is false but R is true
- (3) Both A and R are true and R is the correct explanation of A
- (4) Both A and R are true but R is NOT the correct explanation of A

143 From the statements given below choose the **correct** option :

- A. The eukaryotic ribosomes are 80S and prokaryotic ribosomes are 70S.
- B. Each ribosome has two sub-units.
- C. The two sub-units of 80S ribosome are 60S and 40S while that of 70S are 50S and 30S.
- D. The two sub-units of 80S ribosome are 60S and 20S and that of 70S are 50S and 20S.
- E. The two sub-units of 80S are 60S and 30S and that of 70S are 50S and 30S.

- (1) A, B, E are true
- (2) B, D, E are true
- (3) A, B, C are true
- (4) A, B, D are true

144 Which one of the following enzymes contains 'Haem' as the prosthetic group?

- (1) Succinate dehydrogenase
- (2) Catalase
- (3) RuBisCo
- (4) Carbonic anhydrase

145 What is the name of the blood vessel that carries deoxygenated blood from the body to the heart in a frog ?

- (1) Pulmonary vein
- (2) Vena cava
- (3) Aorta
- (4) Pulmonary artery

146 Given below are the stages in the life cycle of pteridophytes. Arrange the following stages in the correct sequence.

- A. Prothallus stage
- B. Meiosis in spore mother cells
- C. Fertilisation
- D. Formation of archegonia and antheridia in gametophyte.
- E. Transfer of antherozoids to the archegonia in presence of water.

Choose the **correct** answer from the options given below :

- (1) D, E, C, A, B
- (2) E, D, C, B, A
- (3) B, A, D, E, C
- (4) B, A, E, C, D

147 The blue and white selectable markers have been developed which differentiate recombinant colonies from non-recombinant colonies on the basis of their ability to produce colour in the presence of a chromogenic substrate.

Given below are two statements about this method:

**Statement I** : The blue coloured colonies have DNA insert in the plasmid and they are identified as recombinant colonies.

**Statement II** : The colonies without blue colour have DNA insert in the plasmid and are identified as recombinant colonies.

In the light of the above statements, choose the **most appropriate** answer from the options given below :

- (1) Statement I is correct but Statement II is incorrect
- (2) Statement I is incorrect but Statement II is correct
- (3) Both Statement I and Statement II are correct
- (4) Both Statement I and Statement II are incorrect

148 Which of the following microbes is NOT involved in the preparation of household products?

- A. *Aspergillus niger*
- B. *Lactobacillus*
- C. *Trichoderma polysporum*
- D. *Saccharomyces cerevisiae*
- E. *Propionibacterium sharmanii*

Choose the correct answer from the options given below:

- (1) ~~C and D~~ only
- (2) C and E only
- (3) ~~A and B~~ only
- (4) A and C only

149 Silencing of specific mRNA is possible via RNAi because of -

- (1) Complementary tRNA
- (2) Non-complementary ssRNA
- (3) Complementary dsRNA
- (4) Inhibitory ssRNA

150 The complex II of mitochondrial electron transport chain is also known as

- (1) Cytochrome c oxidase
- (2) NADH dehydrogenase
- (3) Cytochrome  $bc_1$
- (4) Succinate dehydrogenase

151 While trying to find out the characteristic of a newly found animal, a researcher did the histology of adult animal and observed a cavity with presence of mesodermal tissue towards the body wall but no mesodermal tissue was observed towards the alimentary canal. What could be the possible coelome of that animal?

- (1) Schizocoelomate
- (2) Spongocoelomate
- (3) Acoelomate
- (4) Pseudocoelomate

152 Given below are two statements :

**Statement I :** In a floral formula  $\oplus$  stands for zygomorphic nature of the flower, and  $\underline{G}$  stands for inferior ovary.

**Statement II :** In a floral formula  $\oplus$  stands for actinomorphic nature of the flower and  $\underline{G}$  stands for superior ovary.

In the light of the above statements, choose the correct answer from the options given below:

- (1) Statement I is correct but Statement II is incorrect
- (2) Statement I is incorrect but Statement II is correct
- (3) Both Statement I and Statement II are correct
- (4) Both Statement I and Statement II are incorrect

153 Given below are two statements :

**Statement I :** In ecosystem, there is unidirectional flow of energy of sun from producers to consumers.

**Statement II :** Ecosystems are exempted from 2<sup>nd</sup> law of thermodynamics.

In the light of the above statements, choose the most appropriate answer from the options given below :

- (1) Statement I is correct but statement II is incorrect
- (2) Statement I is incorrect but statement II is correct
- (3) Both statement I and statement II are correct
- (4) Both statement I and statement II are incorrect

154 Which of the following is the unit of productivity of an Ecosystem?

- (1)  $\text{KCal m}^{-3}$
- (2)  $(\text{KCal m}^{-2})\text{yr}^{-1}$
- (3)  $\text{gm}^{-2}$
- (4)  $\text{KCal m}^{-2}$

- 155 With the help of given pedigree, find out the probability for the birth of a child having no disease and being a carrier (has the disease mutation in one allele of the gene) in F<sub>3</sub> generation.

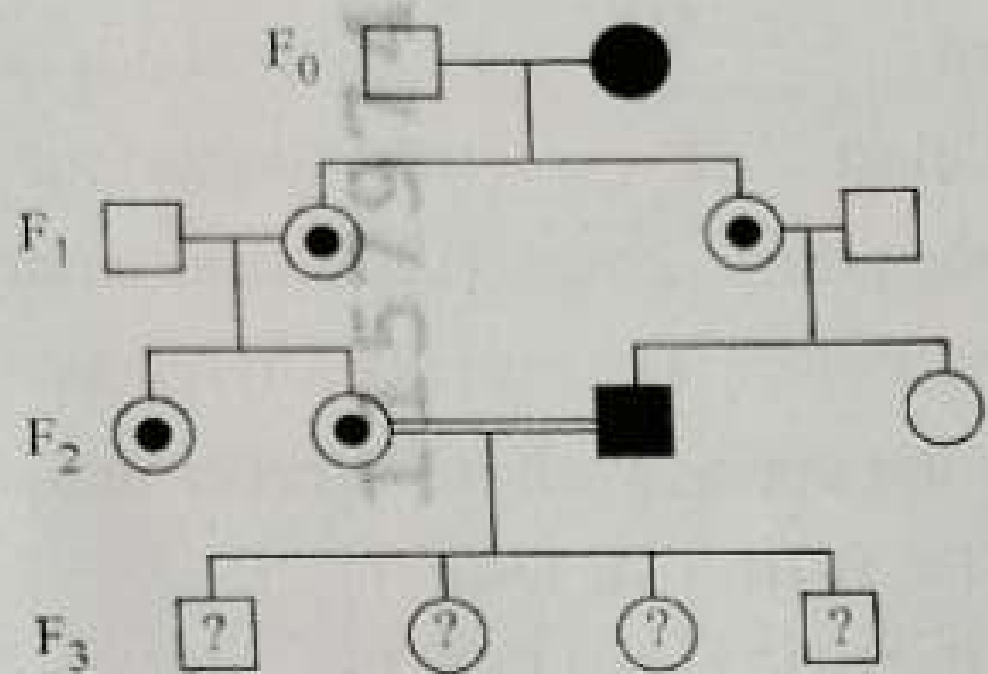

- Unaffected male  
 ■ Affected male  
 ● Carrier female  
 ○ Unaffected female  
 ● Affected female

- (1) 1/8                      (2) Zero  
 (3) 1/4                      (4) 1/2

- 156 In the seeds of cereals, the outer covering of endosperm separates the embryo by a protein-rich layer called :

- (1) Integument  
 (2) Aleurone layer  
 (3) Coleoptile  
 (4) Coleorhiza

- 157 Match List I with List II :

List I		List II	
A. Chlorophyll a	I. Yellow-green		
B. Chlorophyll b	II. Yellow		
C. Xanthophylls	III. Blue-green		
D. Carotenoids	IV. Yellow to Yellow-orange		

Choose the option with all correct matches.

- (1) A-I, B-II, C-IV, D-III  
 (2) A-I, B-IV, C-III, D-II  
 (3) A-III, B-IV, C-II, D-I  
 (4) A-III, B-I, C-II, D-IV

- 158 Who proposed that the genetic code for amino acids should be made up of three nucleotides?

- (1) Jacque Monod  
 (2) Franklin Stahl  
 (3) George Gamow  
 (4) Francis Crick

- 159 Histones are enriched with -

- (1) Phenylalanine & Leucine  
 (2) Phenylalanine & Arginine  
 (3) Lysine & Arginine  
 (4) Leucine & Lysine

- 160 Which of the following enzyme(s) are NOT essential for gene cloning?

- A. Restriction enzymes  
 B. DNA ligase  
 C. DNA mutase  
 D. DNA recombinase  
 E. DNA polymerase

Choose the **correct** answer from the options given below :

- (1) -D and E only  
 (2) B and C only  
 (3) C and D only  
 (4) A and B only

- 161 A specialised membranous structure in a prokaryotic cell which helps in cell wall formation, DNA replication and respiration is :

- (1) Cristae  
 (2) Endoplasmic Reticulum  
 (3) Mesosome  
 (4) Chromatophores

- 162 Which factor is important for termination of transcription?

- (1) ρ (rho)                      (2) γ (gamma)  
 (3) α (alpha)                      (4) σ (sigma)

163 Which of the following statement is correct about location of the male frog copulatory pad ?

- (1) Second digit of fore limb
- (2) First digit of the fore limb
- (3) First and Second digit of fore limb
- (4) First digit of hind limb

164 Which of the following diagrams is correct with regard to the proximal (P) and distal (D) tubule of the Nephron.

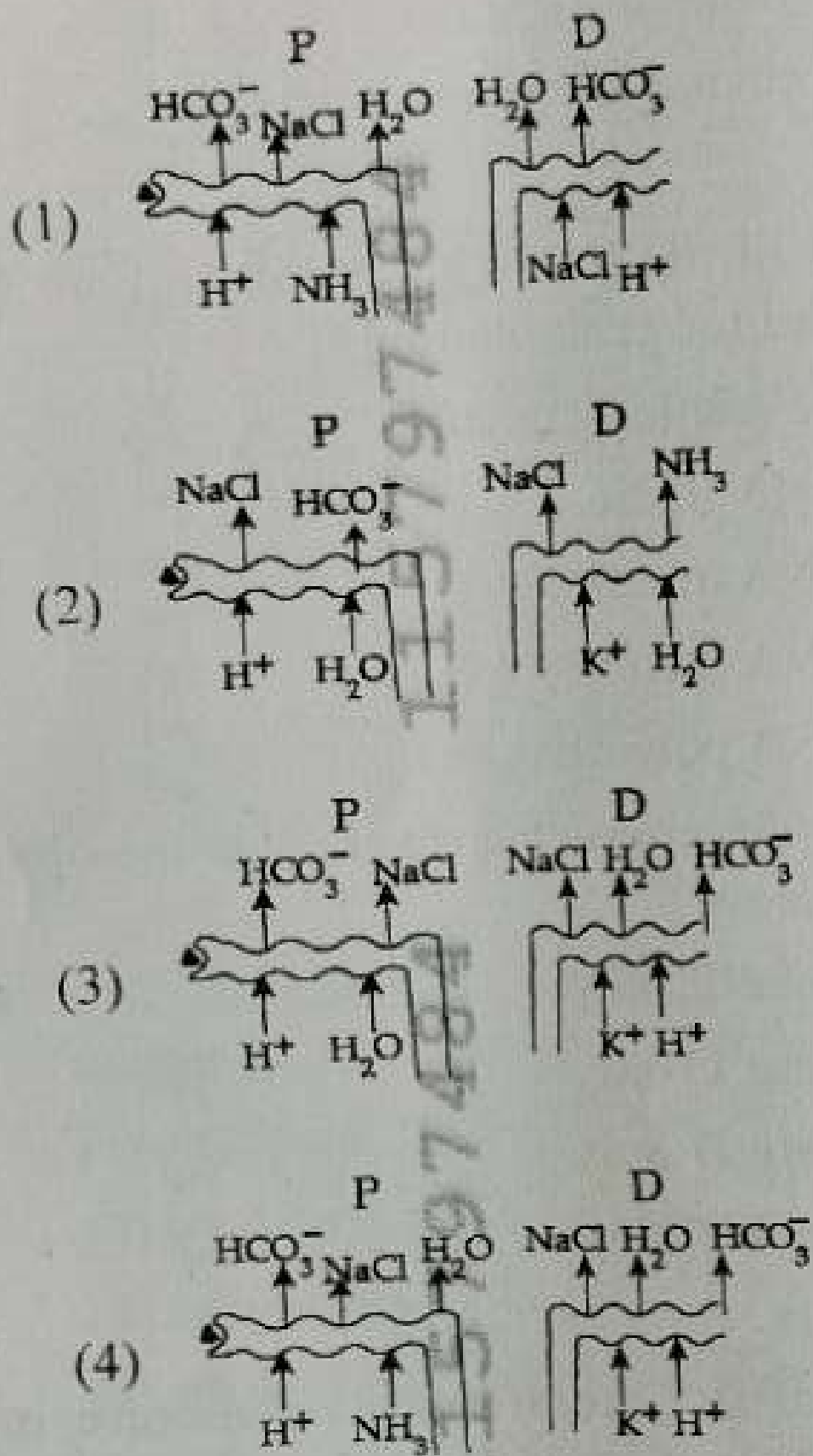

165 Identify the statement that is NOT correct.

- (1) Antigen binding site is located at C-terminal region of antibody molecules.
- (2) Constant region of heavy and light chains are located at C-terminus of antibody molecules.
- (3) Each antibody has two light and two heavy chains.
- (4) The heavy and light chains are held together by disulfide bonds.

166 Match List I with List II :

List I  
A. Scutellum

B. Non-albuminous seed

C. Epiblast

D. Perisperm

List II

I. Persistent nucellus

II. Cotyledon of Monocot seed

III. Groundnut

IV. Rudimentary cotyledon

Choose the option with all correct matches.

- (1) A-IV, B-III, C-I, D-II
- (2) A-II, B-IV, C-III, D-I
- (3) A-II, B-III, C-IV, D-I
- (4) A-IV, B-III, C-II, D-I

167 Find the statement that is NOT correct with regard to the structure of monocot stem.

- (1) Vascular bundles are conjoint and closed.
- (2) Phloem parenchyma is absent.
- (3) Hypodermis is parenchymatous.
- (4) Vascular bundles are scattered.

168 Twins are born to a family that lives next door to you. The twins are a boy and a girl. Which of the following must be true?

- (1) They were conceived through in vitro fertilization.
- (2) They have 75% identical genetic content.
- (3) They are monozygotic twins.
- (4) They are fraternal twins.

169 Sweet potato and potato represent a certain type of evolution. Select the correct combination of terms to explain the evolution.

- (1) Homology, convergent
- (2) Analogy, divergent
- (3) Analogy, convergent
- (4) Homology, divergent

170 Which one of the following phytohormones promotes nutrient mobilization which helps in the delay of leaf senescence in plants?

- (1) Gibberellin (2) Cytokinin  
(3) Ethylene (4) Abscisic acid

171 Why can't insulin be given orally to diabetic patients?

- (1) Because of structural variation  
(2) Its bioavailability will be increased  
(3) Human body will elicit strong immune response  
(4) It will be digested in Gastro-Intestinal (GI) tract

172 Name the class of enzyme that usually catalyze the following reaction :



Where, G → a group other than hydrogen

S → a substrate

S<sup>#</sup> → another substrate

- (1) Transferase (2) Ligase  
(3) Hydrolase (4) Lyase

173 Given below are two statements :

**Statement I :** The DNA fragments extracted from gel electrophoresis can be used in construction of recombinant DNA.

**Statement II :** Smaller size DNA fragments are observed near anode while larger fragments are found near the wells in an agarose gel.

In the light of the above statements, choose the **most appropriate** answer from the options given below :

- (1) Statement I is correct but statement II is incorrect  
(2) Statement I is incorrect but statement II is correct  
(3) Both statement I and statement II are correct  
(4) Both statement I and statement II are incorrect

174 The correct sequence of events in the life cycle of bryophytes is

- A. Fusion of antherozoid with egg.  
B. Attachment of gametophyte to substratum.  
C. Reduction division to produce haploid spores.  
D. Formation of sporophyte.  
E. Release of antherozoids into water.

Choose the **correct** answer from the options given below :

- (1) B, E, A, D, C  
(2) D, E, A, B, C  
(3) D, E, A, C, B  
(4) B, E, A, C, D

175 Genes R and Y follow independent assortment. If RRRYY produce round yellow seeds and rrryy produce wrinkled green seeds, what will be the phenotypic ratio of the F<sub>2</sub> generation?

- (1) Phenotypic ratio - 9 : 3 : 3 : 1  
(2) Phenotypic ratio - 9 : 7  
(3) Phenotypic ratio - 1 : 2 : 1  
(4) Phenotypic ratio - 3 : 1

176 Each of the following characteristics represent a Kingdom proposed by Whittaker. Arrange the following in increasing order of complexity of body organization.

- A. Multicellular heterotrophs with cell wall made of chitin.  
B. Heterotrophs with tissue/organ/organ system level of body organization.  
C. Prokaryotes with cell wall made of polysaccharides and amino acids.  
D. Eukaryotic autotrophs with tissue/organ level of body organization.  
E. Eukaryotes with cellular body organization.

Choose the **correct** answer from the options given below :

- (1) A, C, E, D, B  
(2) C, E, A, B, D  
(3) A, C, E, B, D  
(4) C, E, A, D, B

177 Match List - I with List - II.

List - I	List - II
A. Centromere	I. Mitochondrion
B. Cilium	II. Cell division
C. Cristae	III. Cell movement
D. Cell membrane	IV. Phospholipid Bilayer

Choose the correct answer from the options given below :

- (1) ~~A-IV, B-II, C-III, D-I~~
- (2) ~~A-II, B-III, C-I, D-IV~~
- (3) A-I, B-II, C-III, D-IV
- (4) ~~A-II, B-I, C-IV, D-III~~

178 Which one of the following equations represents the Verhulst-Pearl Logistic Growth of population?

(1)  $\frac{dN}{dt} = rN \left( \frac{N-K}{N} \right)$

(2)  $\frac{dN}{dt} = N \left( \frac{r-K}{K} \right)$

(3)  $\frac{dN}{dt} = r \left( \frac{K-N}{K} \right)$

(4)  $\frac{dN}{dt} = rN \left( \frac{K-N}{K} \right)$

179 Match List - I with List - II.

List - I	List - II
A. Emphysema	I. Rapid spasms in muscle due to low $Ca^{++}$ in body fluid
B. Angina Pectoris	II. Damaged alveolar walls and decreased respiratory surface
C. Glomerulonephritis	III. Acute chest pain when not enough oxygen is reaching to heart muscle
D. Tetany	IV. Inflammation of glomeruli of kidney

Choose the correct answer from the options given below :

- (1) A-II, B-IV, C-III, D-I
- (2) A-II, B-III, C-IV, D-I
- (3) A-III, B-I, C-IV, D-II
- (4) A-III, B-I, C-II, D-IV

180 Cardiac activities of the heart are regulated by :

- A. Nodal tissue
- B. A special neural centre in the medulla oblongata
- C. Adrenal medullary hormones
- D. Adrenal cortical hormones

Choose the correct answer from the options given below :

- (1) A, C and D Only
- (2) A, B and D Only
- (3) A, B and C Only
- (4) A, B, C and D